

MORE

CAPACITY • ACCURACY • POWER

RB30T Heavy-Duty Wheel Balancer

SKU# 5140179



MAXIMUM POWER
MEETS PRECISION

LUG-CENTRIC
MOUNTING PRESSURE
PLATE ADAPTER KIT
INCLUDED

One Machine. Total Coverage.

When your shop's reputation rides on the balance of every wheel, the equipment you choose isn't just a tool; it's your margin, your time, your name. The Ranger RB30T Truck Wheel Balancer was built for that level of pressure. Specifically designed for commercial truck fleets and high-volume tire shops, the RB30T tackles the most demanding balancing jobs with factory-grade precision and reliability. The RB30T seamlessly handles everything from passenger vehicles to heavy-duty truck and OTR wheels. Its advanced dual dynamic programming architecture automatically adjusts RPM and measurement resolution based on the selected mode—delivering optimal accuracy and performance every time. One machine. Total coverage.

Purpose-Built, Not Repurposed

The RB30T isn't just another "heavy-duty" option; it's a fully re-engineered platform. A maximum capacity of 330 lbs, tire diameters up to 47.25", and widths up to 20" are only part of the story. This machine's specs read like it was built by technicians who've wrestled with the biggest wheels and didn't settle for workarounds. Its cycle times hit 7 seconds for passenger car wheels and around 20 seconds for full truck assemblies, making it fast enough for volume and tough enough for the busiest shops. Switching between truck and car mode is just a button away, allowing seamless transitions between wheel types without extra steps or recalibration.

Smarter Tech, Better Balancing

At the heart of the RB30T is Ranger's Drive-Check™ system, a smart balancing tech that simulates real-world conditions and hunts down even the subtlest vibrations before they show up on the road. This isn't basic "spin and guess" balancing—it's high-sensitivity detection backed by a high-speed microprocessor and a full suite of quartz piezoelectric sensors that measure across longitudinal, transverse, and shear axes. Once an imbalance is detected, the RB30T recommends the most efficient correction, saving time, reducing waste, and increases tire longevity for your customers..

Engineered to Endure

It's more than smart, it's built to last. A rugged ribbed nylon-fiber drive belt and counter-weighted flywheel system deliver smooth operation under extreme loads, while the single-phase motor maintains consistent torque without the maintenance headaches of older systems. The 40 mm main shaft is constructed of hardened steel, machined for accuracy, repeatability, and durability. It's designed to hold its own under daily use.

64-tooth Encoder Improves Automatic Weight Optimization

RB30T weight calculations are up to twice as accurate as other units, delivering precise balance across most wheel setups. A 64-tooth magnetic transducer encoder improves placement readouts for optimal positioning, reducing weight use, saving time, and boosting profitability.

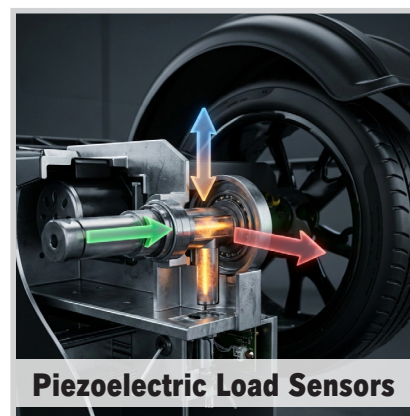

Anyone who's spent time behind a wheel balancer knows the most important moment comes after the spin cycle. That's when the machine tells you exactly where the correction weight needs to go. Get that placement right and the job is done in one shot. Miss it by even a small margin and you're running another spin.

That's Why The RB30T's Dual-Laser Guidance System Is Such A Powerful Feature.

Instead of forcing the operator to estimate the position, the RB30T projects precise laser markers that show exactly where the correction weight belongs. The system includes both top and bottom lasers to give the technician a clear visual target regardless of wheel type or balancing mode.

It's Simple, Intuitive, And Incredibly Effective.

The top laser provides a direct reference point for traditional weight placement. As soon as the machine calculates imbalance, the laser marks the exact location on the rim where weight should be applied. There's no need to eyeball angles or interpret small reference marks on the wheel. The laser shows the position instantly, helping technicians move quickly and confidently through the balancing process.

Operator-Focused for Faster Workflow

Ease-of-use features are dialed in for real-world speed. A built-in pneumatic lift handles the heaviest wheels with minimal effort. An electro-pneumatic braking system locks wheels dead-on for accurate weight placement. Top-dead-center and bottom-dead-center modes give techs flexibility with clip-on or stick-on weights, and a bright LED display provides the perfect placement in seconds.

Ready for the Grind

Even storage and workflow get an upgrade. A spacious top tray holds an arsenal of wheel weights, while side shelves and cone pegs keep everything organized and ready for rapid-fire balancing. The machine is shipped with a full multi-piece commercial mounting kit, including all necessary cones and adapters to start balancing from day one, with no upsells required.

Productivity Without Compromise

For tire shops chasing efficient throughput, and fleet operations who can't afford downtime, the RB30T is the kind of upgrade that pays for itself fast. It's a purpose-driven powerhouse that combines old-school durability with cutting-edge tech, giving you the confidence to tackle every wheel that rolls through your bay without hesitation or compromise.

Ample Storage

Integrated weight trays, cone hangers, and tool holders keep RB30T accessories organized and within reach. Everything stays on the machine; reducing clutter, speeding workflows, and keeping high-volume truck balancing efficient and repeatable.



**Upper Weight-Placement
Aide Laser**



**Lower Weight-Placement
Aide Laser**



**Storage Shelf &
Cone Hangers**



Ample Storage

Standard Cone Kit

The RB30T tooling package includes a fully equipped, eight-piece cone kit engineered for precise, repeatable wheel centering across a wide range of applications - from passenger cars and light trucks to super-duty trucks, buses, and OTR assemblies. Manufactured from hardened, precision-machined steel for maximum durability and long service life, each cone is designed to deliver accurate mounting under demanding shop conditions. Cone sizes range from 2" to 11.50", providing comprehensive coverage for virtually any wheel configuration. All components are designed to fit a standard 40 mm threaded shaft for seamless compatibility and reliable performance.

Car Mode and Truck Mode

With a dedicated Car Mode and Truck Mode, the RB30T is engineered to adapt to the wheel you're working on, delivering accurate balance whether you're spinning a lightweight alloy passenger wheel or a heavy-duty truck assembly. Instead of forcing technicians to work around a one-size-fits-most system, the machine adjusts its balancing strategy to match the demands of the job.

Flip the machine into Car Mode, and the RB30T behaves like a precision passenger-vehicle balancer. The system is optimized for the lighter assemblies found on modern sedans, coupes, and SUVs. These wheels often require delicate corrections and precise weight placement, especially when dealing with low-profile tires and wide alloy rims.

Activate Truck Mode, and the machine adjusts its operating parameters to handle the increased mass and inertia of larger wheels and tires. Larger wheels generate significantly different forces during rotation. They require a balancing system capable of managing greater loads while still delivering accurate results. Truck Mode is built for exactly that scenario.

Lug-Centric Mounting Pressure Plate Adapter & Self-Centering Jaw Clamping Chuck

Proper wheel balancing starts with proper mounting. If the wheel isn't secured correctly on the shaft, even the most advanced balancer can't deliver accurate results. That's why the RB30T includes two specialized mounting systems designed to handle a wide range of wheel designs and hub configurations.

The first is the Lug-Centric Mounting Pressure Plate Adapter. This large mounting plate uses integrated guide pins that align with the wheel's lug holes, allowing the wheel to be secured using the same reference points that center it on the vehicle hub.

The RB30T also includes a Self-Centering Jaw Clamping Chuck, designed to handle wheel assemblies that cannot be mounted using traditional cone systems or lug-based mounting.



Ergonomic Design



Lug-Centric Mounting Pressure Plate Adapter



Self-Centering Jaw Clamping Chuck

ENHANCED FEATURES

- **Multi-directional quartz piezoelectric sensors** capture vibration across multiple axes
- **True Dual-Purpose Balancing** seamlessly handles passenger vehicles and heavy-duty truck and OTR wheels.
- **Detects** longitudinal, transverse, and shear imbalances simultaneously
- **High-resolution vibration detection** improves balance accuracy
- **Dual-Laser Precision Guidance** eliminates weight placement guesswork with pinpoint accuracy—upper and lower lasers precisely guide adhesive weight placement in ALU modes.
- **Laser guidance system** works across passenger and truck wheels
- **Improves accuracy** when working behind spokes on alloy wheels
- **Precision diagnostics** reduce repeat balancing cycles
- **Supports** modern wide wheels, aggressive offsets, and low-profile tires
- **Ideal for modern wheels** where hidden weights are required
- **Dedicated Car Mode and Truck Mode** for optimized balancing
- **Machine automatically adapts** to light passenger wheels or heavy truck assemblies
- **Passenger mode** tuned for precision balancing of modern vehicles
- **Truck mode** engineered for high-mass wheel assemblies
- **Seamless transition** between vehicle types
- **Passenger wheel cycle times** as fast as 7 seconds
- **Truck wheel balancing** completed in roughly 20 seconds
- **Supports wheels** up to 49.25" in diameter, 20" wide, and up to 330 lbs in weight
- **Dual-unit display** provides both gram/ounce and inch/millimeter readouts
- **Durable ribbed nylon-fiber** reinforced serpentine belt resists wear and slippage under load
- **Top tray and side shelving** offer generous onboard storage for weights, cones, and tools
- **Includes full heavy-duty cone and commercial adapter kit**; everything you need is in the box
- **Cone sizes** range from 2" to 11.50"
- **Built-in air regulator and oiler system** ensures reliable pneumatic lift operation, other compressed-air driven equipment often requires the customer to supply oiled & regulated compressed air
- **Manual or automatic start** options when the hood is lowered, customizable for the technician workflow
- **Touch pad interface** with intuitive LED guidance and clear operator prompts
- **Error-code diagnostics** streamline troubleshooting and service
- **Engineered** to operate in high-heat, high-humidity environments up to 122°F and 85% humidity

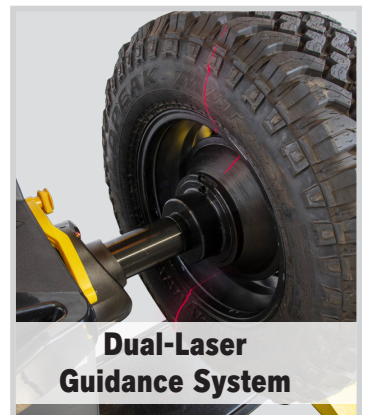
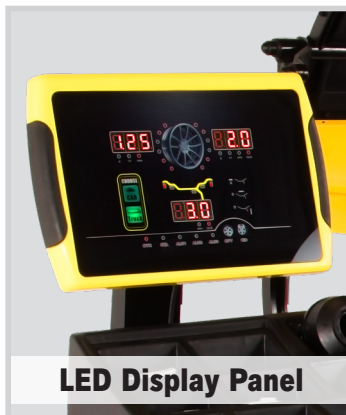

RB30T OVERVIEW



SPECIFICATIONS

Model	RB30T Wheel Balancer
Voltage	208 - 240V 50/60 Hz, 1 Ph*
FLA	11A
Air Source Required	8-20 CFM, 100-145 PSI (7-10 bar)
Working Temperature	32° to 122° F (0° to +50° C)
Max. Tire Diameter	47.25" (1,200 mm)
Max. Wheel Weight	330 lbs. (150 kg)
Max. Wheel Diameter	13" - 24" (330 - 610 mm)
Wheel Width Capacity	4" to 20" (102 mm - 508 mm)
Balancing Increments	0.035 oz (1 gram)
Height, Guard Up	65" (1,651 mm)
Height, Guard Down	52" (1,321 mm)
Overall Width	70" (1,778 mm)
Depth, Cover Up	67" (1,016 mm)
Shaft Size	1.5" (40 mm)
Unit / Shipping Weight	883 lbs. (402 kg) / 947 lbs. (431 kg)

*Note: Standard electrical configurations shown. Additional voltage options available upon request.

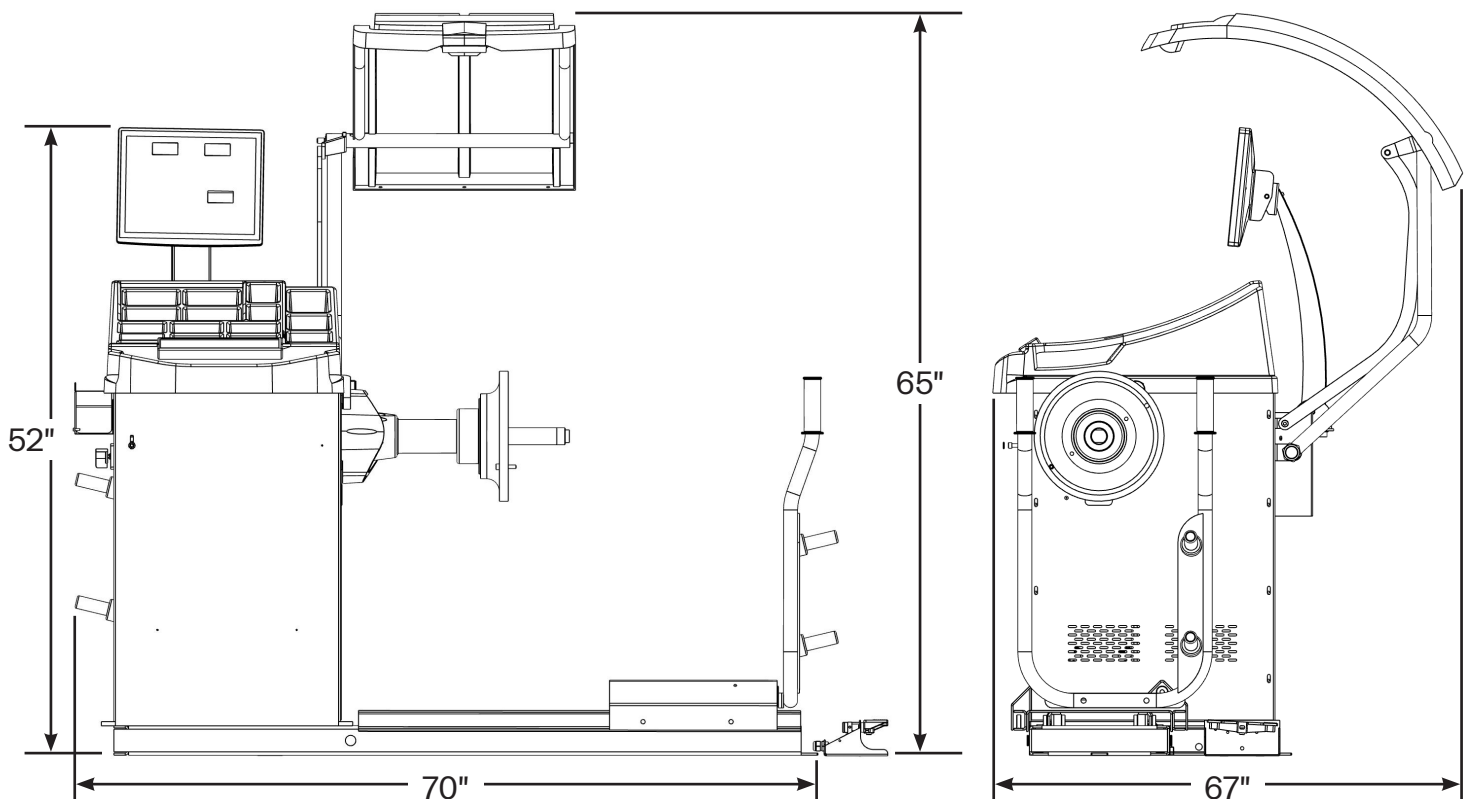

STANDARD ACCESSORIES

Accessory kit includes cones, spacer rings, jaw chuck cones, and a quick nut for precise wheel mounting. Reverse bowls and rubber ring support alternate mounting methods. Calibration weights and calipers ensure accuracy, while weight pliers and tools improve workflow. Motor belt, springs, shafts, and hardware provide durability, stability, and reliable operation in high-volume shop environments. Cone sizes range from 2" to 11.50".

CONES



Cone sizes range from 2" to 11.50"

MOUNTING ADAPTERS

Self Centering Jaw Clamping Chuck



Lug-Centric Mounting Pressure Plate



ESSENTIALS



QUICK NUT



SPACERS



OPTIONAL ACCESSORIES

Adhesive Steel Wheel Weight COMBO Set
SKU 5150230

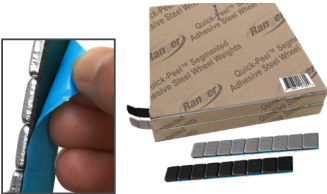

BLACK Adhesive Steel Wheel Weights
SKU 5150225



SILVER Adhesive Steel Wheel Weights
SKU 5150220

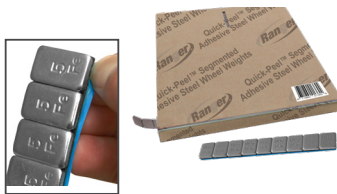

Wheel Weight Dispenser Stand
Stand Only - SKU 5328502
Stand Kit - SKU 5150028
• Stand and Weights



Disclaimer: Specifications, features, and options are subject to change without notice. Illustrations may show optional equipment or accessories sold separately. Maximum wheel sizes, weights, and capacities are approximate and may vary depending on wheel type, condition, and application. Always follow manufacturer guidelines and local safety regulations when operating equipment.