

BendPak®

10AP SERIES

10AP | 10AP-168 | 10APX | 10APX-181



**ADAPTABLE DESIGN
SYMMETRIC OR ASYMMETRIC**



**360° ASARS
AUTOMATIC SWING ARM
RESTRAINT SYSTEM**

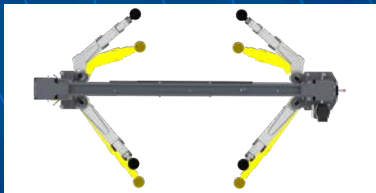

Bi-Metric Swing Arms



Triple-Telescoping



Innovative Safety Lock

1-800-253-2363 | WWW.BENDPAK.COM



WHO WE ARE



ABOUT US

The story of BendPak is not a simple one. It's a story of a vision and generations of people with a common mission - to be the best. Our story became a movement, and today, BendPak is a global conglomerate and lifestyle brand that has crossed geographical boundaries and established its presence across countries and continents.

Our culture is one that embraces different skills celebrating our diversity, and one that strives for continuous innovation providing end-to-end solutions for our customers. It's that commitment that is truly a way of life for every employee of BendPak, anywhere in the world. The impact of this can be seen in the lives that we have changed. We provide the world with products that make a difference in performance, and productivity. We've been changing the way business is done for over a half-century.

TIMELINE



Bend-Pak



1965

Quality Machine & Associates is established as a manufacturing company and quickly gains a reputation as being the premier manufacturer of specialized tools and equipment.

1979

QMA invents and introduces a hydraulic tubing bender designed for muffler shops. The brand name BendPak (originally hyphenated as "Bend-Pak") is born.

1984

BendPak establishes itself as a leading performer in the car lift space by introducing a first-of-its-kind electric-hydraulic surface-mounted four-post lift.

A BRAND THAT SPEAKS

Over five decades of dominance in our industry has earned BendPak lifestyle-brand status. It's a brand that people crave. Consumers want an incredible experience; something that motivates them to invest and buy, and no other lift company inspires loyalty and conversion more than BendPak. We earn our customers by offering them more than just a product, but a way of life. We understand their needs and the experiences they desire, as well as the people, things, and places that inspire them – we know what makes them tick.

We've been successful by defining what our customers strive to become in the future, and giving them the solutions that will help them achieve that goal. It's not just about owning a BendPak; it's about living the life of someone who does own a BendPak.

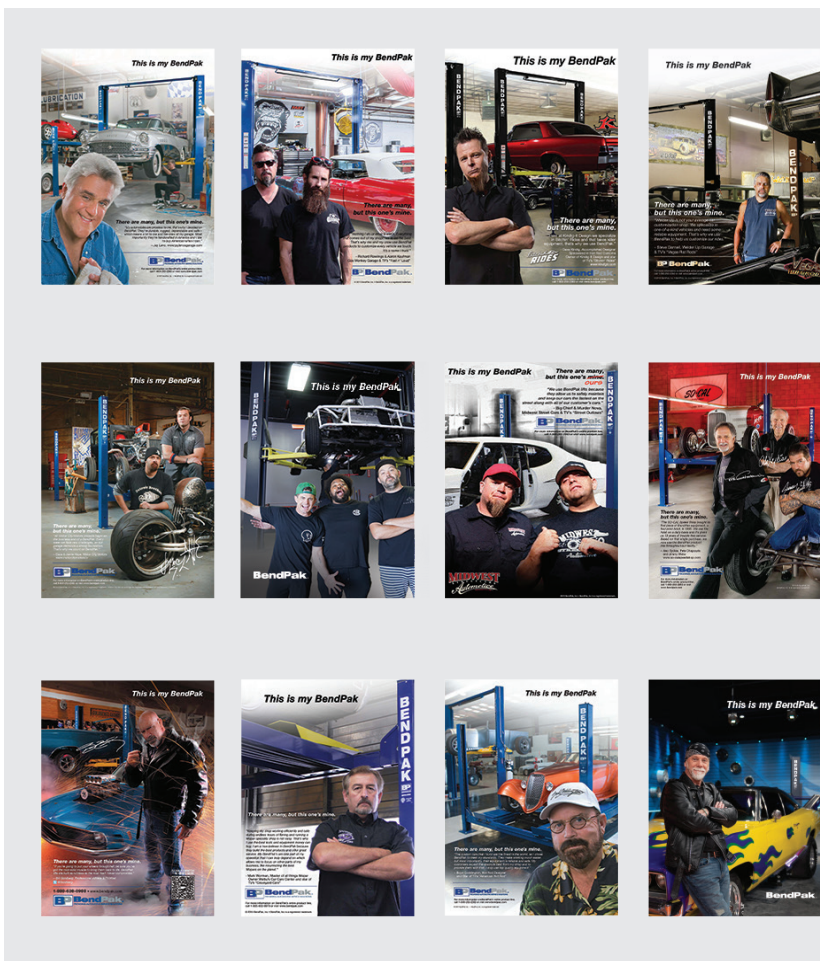

1997

BendPak unveils their newest line of shop equipment: Ranger Products™. Today, Ranger is associated with world-class wheel service equipment and shop essentials.



2015-PRESENT

With over 5,000 SKU's, nine different brands, and an ever-evolving North American operation, BendPak asserts itself as the best shop equipment company in the world.

NEW TECHNOLOGY FOR INCREASED OPERATOR SAFETY

Throughout history, the car industry has always been one of the most receptive industries to emerging technologies. Technology has already redefined the way cars use fuel, with electric, hybrid and solar energy systems beginning to displace the internal combustion engine and gas-fed engines as the driving force of the future. Forecasters are projecting Electric Vehicles (EV's) to account for a large percentage of all vehicles produced and sold in the future, and EV's weigh considerably more than traditional gasoline or diesel-powered vehicles. Those extra pounds have important implications for a technician's safety when that vehicle is raised in the air for service. Extra vehicle weight introduces a lot more stress on automotive lift components, especially when two-post lifts are being considered.

Electric vehicles are getting larger and heavier. Are you ready?

With the emergence of heavier EV's as the impetus for the new 10AP design, technicians are now able to more efficiently service electric vehicles, including trucks, vans, and sports cars. In addition to providing greater under-car access thanks to extremely low-profile arms and extra-wide column spacing, BendPak engineers focused on the use of high tensile-strength steels for all critical load-holding components. The increased tensile strength allowed our engineers to design swing arms with greater telescoping movement and tube profiles better suited for use on low ground-clearance vehicles and outer-positioned EV vehicle lifting points. Safety-critical design enhancements are introduced throughout.

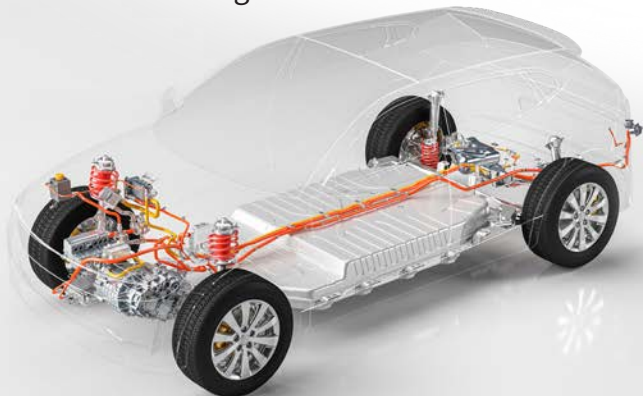

All-electric SUV's and trucks are expected to have curb weights exceeding 9,000 pounds. Those extra pounds have important implications for a technician's safety when that vehicle is raised in the air for service.

Electric vehicles are heavier because of the added batteries, reinforced framework and suspension, and the metal armor around the battery to protect it. That has important implications for car lift safety. From reinforced construction to purposefully engineered design features, the 10AP is the perfect EV service solution. Each 10AP model provides greater under-car access thanks to extremely low-profile arms and extra-wide column spacing. Increased arm travel and minimum arm retraction allow for more versatile lift support positioning, which is perfectly suited for electric vehicle service.

A NEW PARADIGM IN LIFTING

Auto repair shops working on the latest technology need to be equipped with the latest and most advanced tools to service them properly; they need to evolve alongside the vehicles they service. BendPak's all-new AP series of two-post lifts feature a revolutionary design that factors the best qualities of today's two-post lift types into a completely new concept in car lift engineering. The result is a lift unlike any other two-post lift on the market, purposefully designed for extreme use, high loads and operator safety and efficiency.

Our 10AP Series offers the convenience of wide or narrow installation wrapped up into one configurable package. This durable, safe, and reliable car lift features an expandable top beam and BI-METRIC™ arms to suit virtually every vehicle lifting requirement – symmetric or asymmetric. The simple, yet highly sophisticated lift design keeps service and maintenance costs to a minimum, delivering lower operating expenses and higher productivity.



AUTOMATIC ARM RESTRAINT SYSTEM PREVENTS UNPLANNED MOVEMENT

Swing arm restraints have been used for decades on two-post lifts to minimize the chance of arms shifting during vehicle loading and service. However, until now, these systems had a difficult time withstanding the excessive forces applied to them when vehicles suddenly and unexpectedly shifted on the support pads or adapters of the far-reaching swing arms; typically due to improper loading or when heavy drivetrain components are added or removed from elevated vehicles causing an unanticipated transference in the center of balance.

A significant design feature that makes BendPak's AP series particularly well-suited for heavy vehicle service is a revolutionary Automatic Swing Arm Restraint System (ASARS) that has been bolstered to withstand these elevated pushing and pulling forces that occur when vehicles are being serviced.

With a full 360-degrees of load holding grip, the heavily forged-steel design of this patented and very exclusive arm restraint system secures the lift arms firmly in place with over 2000-pounds of load-holding force, preventing unplanned swing arm movement during lift use and vehicle service operations. This revolutionary design is an adaptive system that requires minimal operator involvement and delivers unparalleled holding power. A distinctive power-hold design that allows for precise non-shifting action, and a handy quick-release operator lever allowing for the instant release of the clamping pressure.

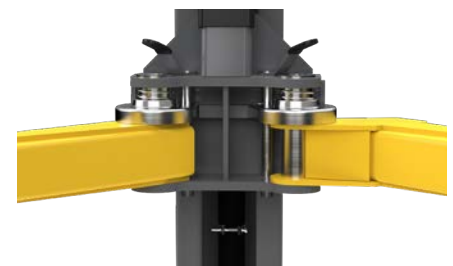
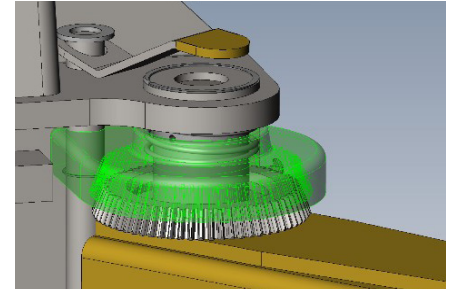

TRIPLE-TELESCOPING NESTED SWING ARM DESIGN

Revolutionary and patented swing arms are specifically tailored for varying vehicle lifting points. Unlike traditional two-post lift arms, 10AP arms retract shorter and extend farther; offering lift operators a myriad of lift arm positioning options — it's like having the best of all worlds.

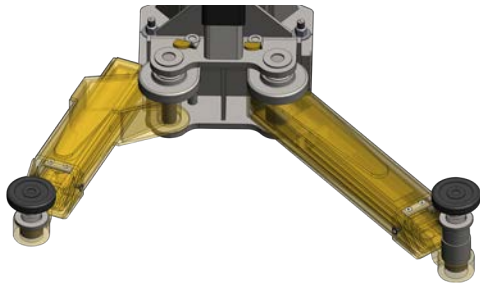

The innovative three-stage arms achieve more telescoping movement due to their patented nesting feature that results in greater retraction and farther reach. Inner sliding arm movement is no longer impeded by arm end plates, tube closeouts, or even the arm pivot pin itself. The inner tubes retract fully through the back of the arm assembly end even beyond the arm pin, resulting in more achievable retraction and extension.

LOW PROFILE ARMS

Double-telescoping screw adapters feature gouge and tear-resistant polyurethane pads that can be screwed up or down to ensure level lifting in all conditions. Provides more precise and secure frame engagement, ensuring technician safety. The optional Short and Medium stackable adapters provide greater vertical pad placement for precise and safe vehicle support.

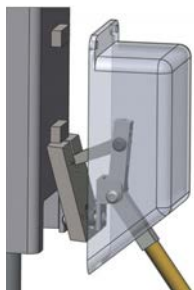

INNOVATIVE SAFETY LOCK SYSTEM

The patented automatic safety lock system is designed to dramatically improve operator efficiency and safety. The simple yet innovative design ensures automatic safety lock engagement during all lift rising operations, and an ergonomic single-point release allows operators to effortlessly release the safety locks during lift descent — literally with a push of a single finger. It's that easy.

SCREW PADS AND ADAPTERS THAT ADJUST TO YOUR NEEDS

Double-telescoping screw adapters feature gouge and tear-resistant polyurethane pads that can be screwed up or down to ensure level lifting in all conditions. Provides more precise and secure frame engagement, ensuring technician safety. The Short and Medium stackable adapters are optional accessories which provide greater vertical pad placement for precise and safe vehicle support. For easy storage, the standard 2-column mounted racks keep adapters neatly organized and secure.

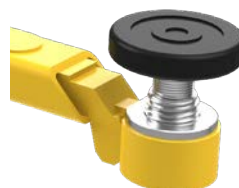

BI-METRIC™ SWING ARMS

Exclusive BI-METRIC™ adaptable swing arms give users the ability to set their lift up in either symmetric or asymmetric configurations. The 2-in-1 design gives operators the option of loading vehicles either symmetrically (centerline of vehicle at column) or asymmetrically (centerline of vehicle behind column). By not having to switch out arms, you'll be able to service vehicles faster than ever before.

ASYMMETRIC CONFIGURATION

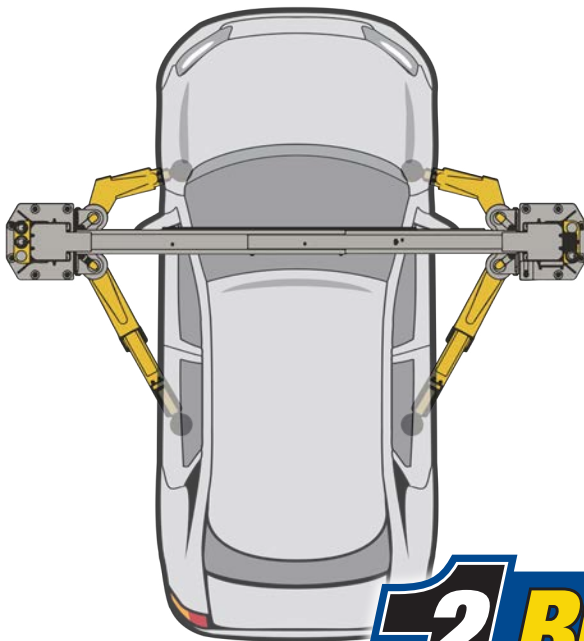

SYMMETRIC CONFIGURATION

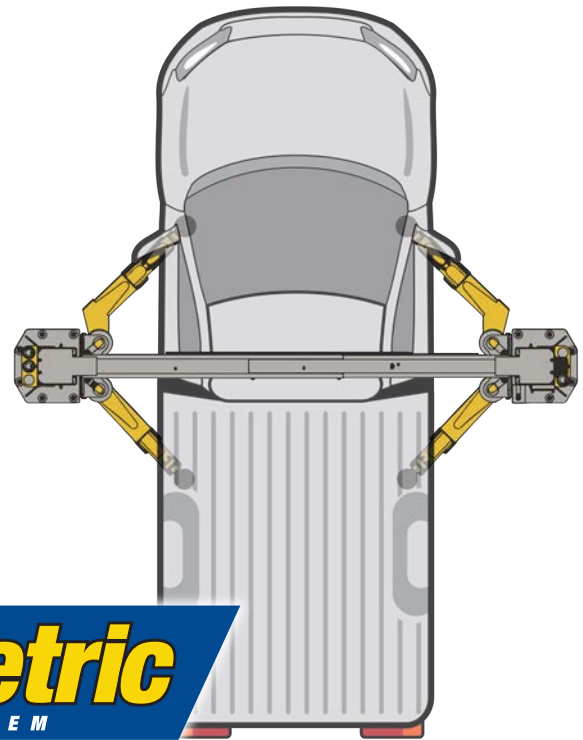

2 *Bi-Metric*
IN LIFT SYSTEM
BendPak®

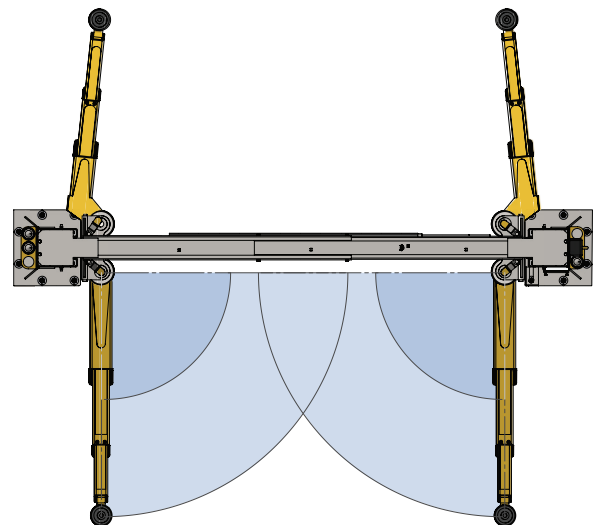
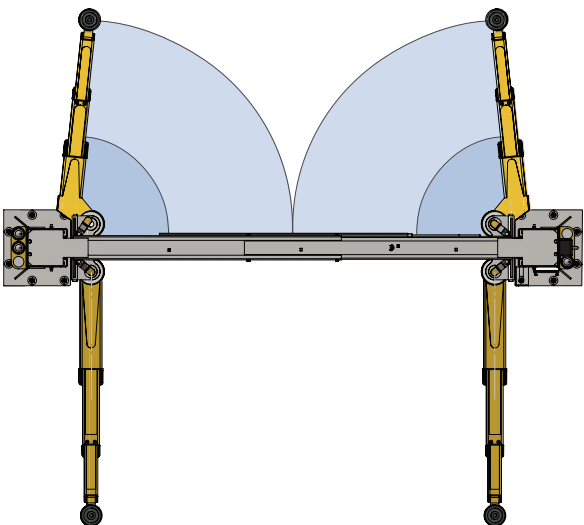

WITH EVERY AP SERIES LIFT YOU GET...

- **Clear-floor convenience** – unobstructed floor space allows technicians the ability to easily move toolboxes, transmission jacks, oil drains, and other equipment underneath elevated vehicles.
- **Bi-Metric™ swing arms** – give users the ability to set their lift up in either symmetric or asymmetric configurations. The 2-in-1 design gives installers and operators the option of loading vehicles either symmetrically (centerline of vehicle at column) or asymmetrically (centerline of vehicle behind column).
- **Low-Pro™ swing arms** – low-profile telescoping swing arms offer less hindrance providing increased versatility and less chance of damage to vehicle side skirts, running boards, or ground effects.
- **Automatic arm restraints** – each arm is equipped with durable 360-degree full-contact geared arm restraints that provide over 2000-pounds of load-holding force and automatically engage each time the lift is raised. When the lift is lowered, the gear-type arm restraints automatically disengage to provide easy positioning of the lift arms.
- **Configurable wide or narrow installation** – allows you to maximize the use of your floor space.
- **Single-piece columns** – we purposely manufacture the columns using single-piece construction for added strength and less fatigue under heavy load conditions.
- **Maintenance free load bearings** – rather than using roller bearings that need constant lubrication and maintenance, every AP series lift carriage uses futuristic ultra-high molecular weight (UHMW) polyethylene load bearings that never need lubrication and last virtually the life of the lift.
- **Dual Direct-Drive technology** – by utilizing two low-pressure Direct-Drive cylinders, we've eliminated the need for lifting chains or screw mechanisms most commonly found on other lift designs. This Direct-Drive technology offers better reliability, smoother operation, and less maintenance. Low pressure means a much smaller workload is placed on the entire hydraulic system.
- **Single-point safety release** – the single-point safety release and dead-man style operation controls makes every one of our AP series lifts easy to operate and safe to use.
- **On the level** – our Dual-Synchro equalization system maintains equal lifting and provides operators with a stable, level vehicle working condition.
- **HVLP hydraulic system** – every AP Series lift uses a High Volume Low Pressure (HVLP) electric-hydraulic power system that delivers high fluid volume while maintaining low system pressure. Because the hydraulics are not constantly under high pressure, seal failure and leakages are much less likely to occur.
- **Industrial-grade hydraulic cylinders** – integrated into every AP Series hydraulic cylinder is a one-piece, pilot-fitted, machined-steel piston wrapped with specially designed, pressure-loaded U-cup piston seals, backups, and wear bands that virtually eliminate any fluid bypass. A micro-smooth chrome rod is machined from high-yield, ground and polished alloy steel and the welded cylinder body exceeds ASTM specifications.
- **Super-tall lift carriages** – 53" & 59" tall carriages are considerably taller than most two-post styles, which minimizes the stress placed on the load bearings and columns.
- **Screw Lift Pad Assembly** – Adjustable screw lift pads provide the operator with a greater level vertical control when operating a BendPak 9,000-lb. or 10,000-lb. two-post car lift. For easy storage, the standard 2-column mounted racks keep adapters neatly organized and secure.
- **Performance Guaranteed** - we're so sure that our lifts will out-perform all others, we're backing that promise with a full five-year warranty. The best warranty in the business gives you more than just peace of mind; it's proof that we took a little extra care building your lift and every precaution was taken to maintain the highest degree of quality, dependability and reliability. For full details visit www.bendpak.com/support/warranty.



FEATURES

- 1 Durable powder coat finish
- 2 Expandable top beam accommodates wide or narrow drive-thru configurations
- 3 Double-telescoping screw pads offer increased versatility
- 4 Padded overhead safety shutoff bar
- 5 Exclusive Bi-Metric™ arm design for more versatile arm positioning
- 6 Single-point safety release
- 7 Drop-end arms provide a lower pad height
- 8 Dual hydraulic direct-drive cylinders
- 9 Oversized 53" & 59" tall carriages for superior strength and durability
- 10 Electric / hydraulic HVLV power system
- 11 Self-lubricating dura-glide UHMW polyethylene bearing system
- 12 Safety locks in each column spaced every 3"
- 13 Automatic arm restraints withstand over 2000-pounds of side force
- 14 Heavy-duty 1/2" aircraft-quality equalizer cables
- 15 Oversized cable sheave diameter reduces cable fatigue
- 16 Adapter Holders come standard
- 17 Four triple-telescoping arms

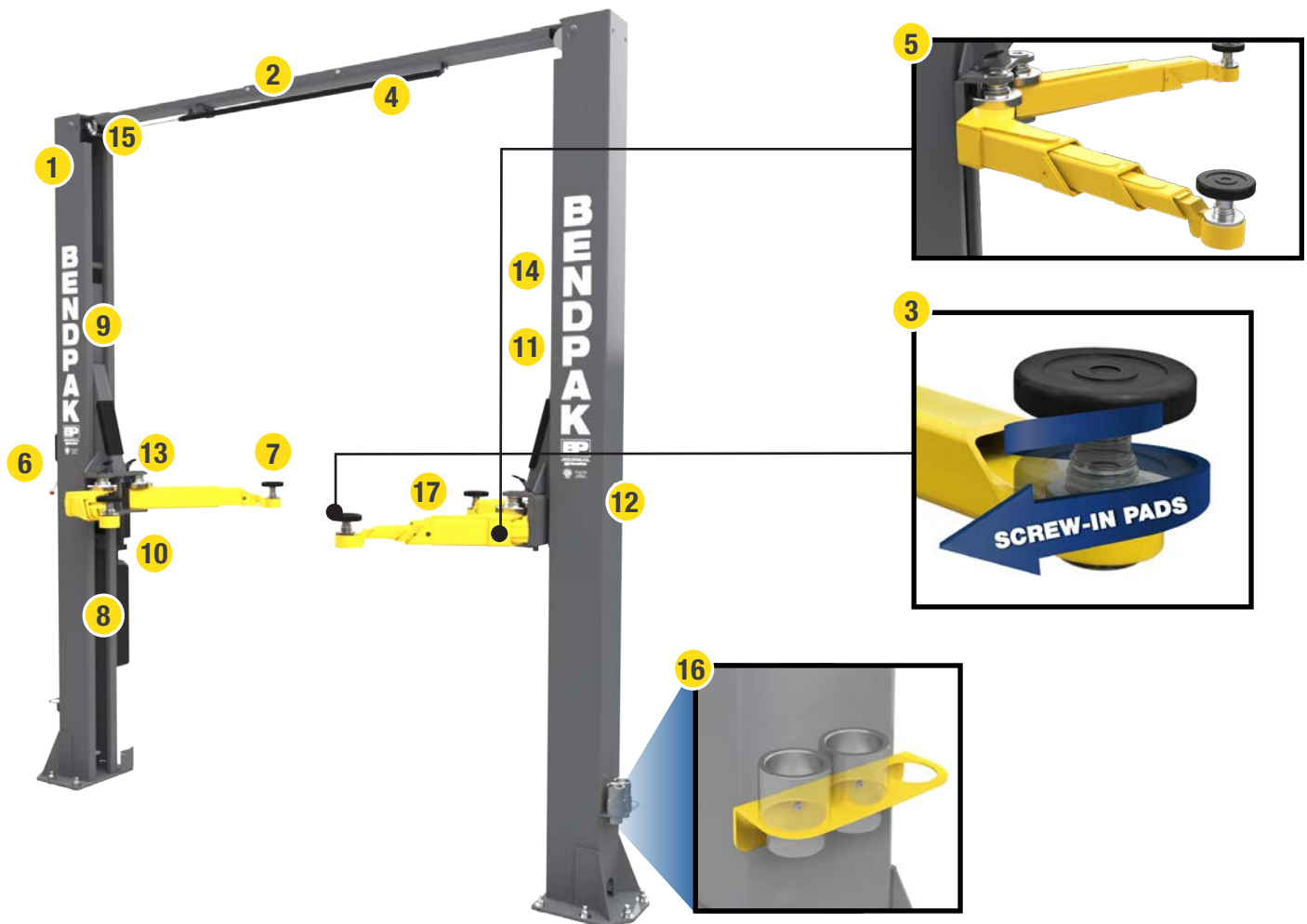



SPECIFICATIONS

Model	10AP	10AP-168	10APX	10APX-181
SKU	5175304	5175305	5175306	5175307
Lifting capacity	10,000 lbs. / 4,536 kg			
Max. Capacity	5,000 / 2,268 kg (Front Axle)		5,000 / 2,268 kg (Rear Axle)	
A – Max. Rise	69 in. / 1,753 mm		75.5 in. / 1,918 mm	
B – Lifting Height ¹	73 in. / 1,854 mm		79.5 in. / 2,019 mm	
C – Max. Lifting Height ¹	82.5 in. / 2,095 mm		89 in. / 2,261 mm	
D – Min. Height ¹	4 in. / 102 mm			
E – Overall Height	145 in. / 3,683 mm	168 in. / 4,267 mm	157 in. / 3,988 mm	181 in. / 4,597 mm
F – Overall Width	135 in. / 3,431 mm (Narrow)		145 in. / 3,683 mm (Wide)	
G – Outside Columns	127.5 in. / 3,238 mm (Narrow)		137.5 in. / 3,492 mm (Wide)	
H – Inside Posts	108.5 in. / 2,756 mm (Narrow)		118.5 in. / 3,010 mm (Wide)	
I – Drive-Thru	92 in. / 2,477 mm (Narrow)		102 in. / 2,731 mm (Wide)	
J – Floor to Top Switch	140 in. / 3,556 mm	163 in. / 4,140 mm	152 in. / 3,861 mm	176 in. / 4,470 mm
K – Front Arm Reach	22 in. / 559 mm (min)		47.5 in. / 1,206.5 mm (max)	
L – Rear Arm Reach	29.5 in. / 750 mm (min)		57 in. / 1,448 mm (max)	
Max. load per Lift Arm	2,500 lbs. / 1,134 kg			
Screw Pad Adjustment	2 in. / 51 mm			
Time to Full Rise ³	≈ 45 seconds			
Motor ²	220 VAC, 60 Hz, 1 Phase			
Sound	<70 dB			

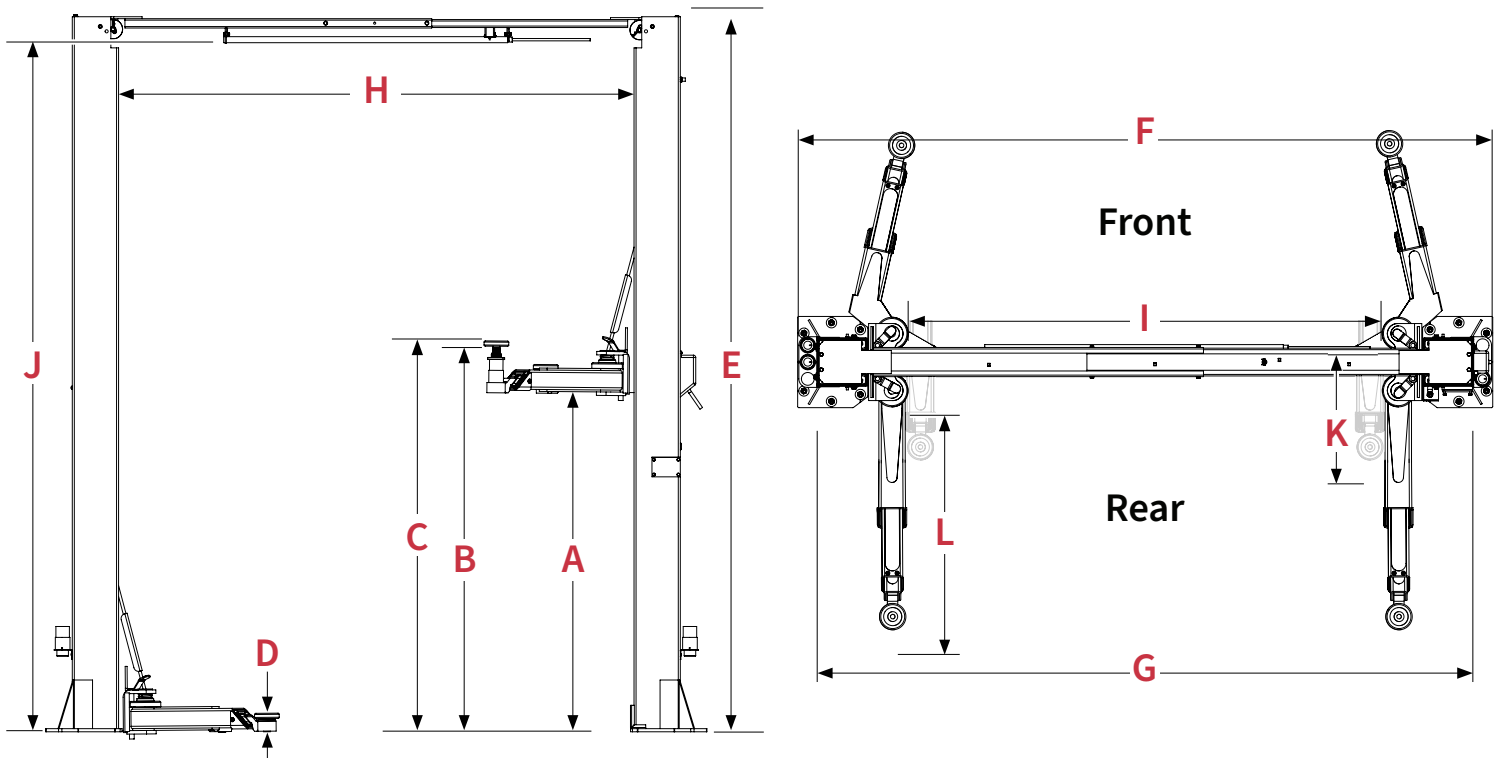
(1) Lifting Height is maximum lifting height of lift with contact pads adjusted to low setting and no adapter(s). Maximum Lifting Height is maximum lifting height of lift with contact pads adjusted to high setting and with both tall and medium adapters installed (Sold Separately). (2) Special voltages available upon request. (3) Actual rise and descent times vary depending on vehicle weight. Specifications subject to change without notice.

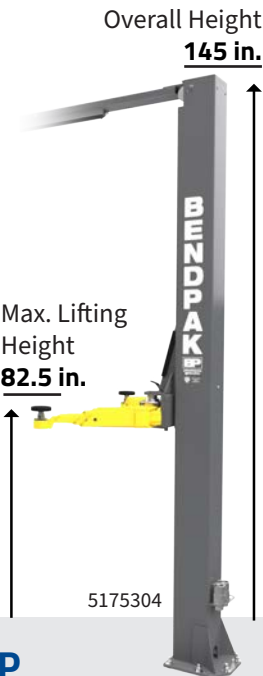
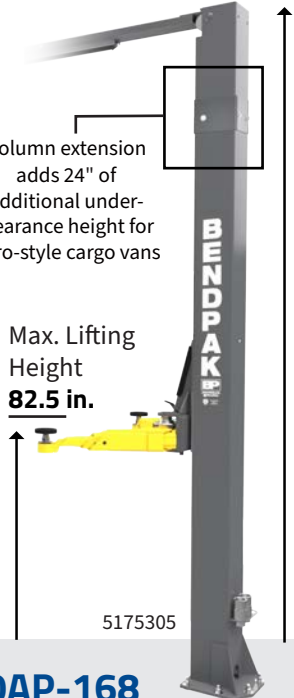

RISE TO NEW HEIGHTS

 <p>Overall Height 145 in.</p> <p>Max. Lifting Height 82.5 in.</p> <p>5175304</p>	 <p>Overall Height 168 in.</p> <p>Column extension adds 24" of additional under-clearance height for Euro-style cargo vans</p> <p>Max. Lifting Height 82.5 in.</p> <p>5175305</p>	 <p>Overall Height 157 in.</p> <p>Max. Lifting Height 89 in.</p> <p>5175306</p>	 <p>Overall Height 181 in.</p> <p>Column extension adds 24" of additional under-clearance height for Euro-style cargo vans</p> <p>Max. Lifting Height 89 in.</p> <p>5175307</p>
<p>10AP</p> <p>This is our standard model that features 73" of lifting height and an overhead beam height of just 145" for shops with lower ceiling clearances.</p>	<p>10AP-168</p> <p>This model features an upper crossbar that's positioned two feet higher to accommodate high roof cargo vans. Features 73" of lifting height and an overhead beam height of 168".</p>	<p>10APX</p> <p>Taller technicians are sometimes at a disadvantage while working under a standard-rise lift. This high-rise model features 79.5" of lifting height and an overhead beam height of 157".</p>	<p>10APX-181</p> <p>Like our 10APX, this high-rise model also features 79.5" of lifting height, but it comes with an overhead beam height of 181" to accommodate high-roof cargo vans.</p>

OPTIONAL ACCESSORIES



5" Tall Adapter
(Set of 4)
SKU 5215759



2.5" Medium Adapter
(Set of 4)
SKU 5215758



2" Low Adapter
(Set of 4)
SKU 5215757



Steel Lift Pads
(Set of 4)
SKU 5215763



Frame Cradle Pads
(Set of 4)
SKU 5215761



Replacement Urethane Pads
(Set of 4)
SKU 5700227



Wide Frame Cradle Pads
(Pair)
SKU 5215848



Air Electric Work Station
(WSA-100)
SKU 5210438

AMERICA'S[®] FAVORITE

SINCE 1965

ELEVATE YOUR EV SERVICE STANDARDS

with the 10AP Two-Post Lift
& Mobi-EVS™



The combination of BendPak's 10AP two-post lift and the Mobi-EVS represents the epitome of enhanced EV service. The 10AP's robust construction and advanced features provide a secure platform for lifting electric vehicles, ensuring both safety and efficiency during maintenance. Its adaptable design accommodates various EV models, while the Mobi-EVS offers unparalleled mobility and convenience for safe and efficient handling of EV battery packs and powertrain systems. This dynamic-duo minimizes downtime and streamlines the service process, catering specifically to the unique demands of electric vehicles.



CALL NOW AND SCHEDULE AN ON-SITE DEMO!

Qualifying businesses can schedule an on-site demo to see the features that set us apart from the competition. To get started, **call 1-800-253-2363** or visit us at www.bendpak.com/mobi-evs-demo

LEARN MORE



10AP Two-Post Lift

Certified to meet the
standards of ANSI/ALI

Mobi-EVS™ EV4500

BendPak makes no promises, guarantees or assurances that our products meet any state, county, federal or international mandated permit, license, code, standard, certification, or any other mandate other than what is listed or shown on BendPak website(s), or any online or published catalog. Not all BendPak lift models meet the standards as prescribed by ANSI/ALI ALCTV-(current edition) or ANSI/UL 201. Consult www.autolift.org for a complete list of lift models that meet ANSI/ALI ALCTV-(current edition) or ANSI/UL 201, or contact BendPak via contact@bendpak.com. Buyer assumes full responsibility for any state, county, federal or international mandated permit, license, code, standard, certification, or any other mandate required related to the installation and/or operation of any BendPak or Ranger product. BENDPAK will not be responsible for any charges, fines, liens, or other levies imposed on the Buyer related to any special or regional structural, seismic or any other building code and/or codes such as the Uniform Building Code (UBC), International Building Code (IBC), or any other state, county, federal or international mandated permit, license, code, standard, certification, or other mandate, law, rule, regulation or directive by any other agency, government, administrations, or corporations whether state, county, federal, or international mandated.

BendPak[®]

1-800-253-2363 | WWW.BENDPAK.COM

© 2024 BendPak Inc. All rights reserved. BendPak is a registered trademark.