

# BendPak®

# Mobi-EVS™

EVS3000 | EVS4500

## EV BATTERY & POWERTRAIN LIFTING SYSTEM

**MADE STRONG™**



**3,000 Lb.**  
Lifting Capacity  
EVS3000

**4,500 Lb.**  
Lifting Capacity  
EVS4500

Equipped with a host of advanced innovations in control and mobility. The Mobi-EVS drives productivity higher; Literally.



Meets or exceeds the standards as prescribed by ASME PASE 2019 (Safety Standard for Portable Automotive Service Equipment)

PATENT PENDING

**1-800-253-2363 | WWW.BENDPAK.COM**

© 2024 BendPak Inc. BendPak is a registered trademark.

\*For comprehensive details about BendPak's 5-2-1 warranty, visit [www.bendpak.com/support/warranty/](http://www.bendpak.com/support/warranty/).



# PRODUCT DETAIL

**BendPak's revolutionary Mobi-EVS™ line** of full-rise battery powered mobile scissor lift tables are perfectly suited for Electric Vehicle Service and EV Battery Pack replacement. With their compact design, these space-saving lift tables can be easily transported anywhere in the workplace, making them ideal for multi-bay facilities or workplaces with confined areas.

With a press of the button on the pendant control, the lift platform elevates to more than 6 feet in less than 20 seconds. Mobi-EVS lift tables feature state-of-the-art engineering and technology within an elegant design that sets a new industry benchmark for performance and versatility.

Our Mobi-EVS models are multi-functional scissor-style lifts that feature multiple recessed anchoring locations to accommodate a variety of modular fixtures, adapters, and accessories. Each can be repositioned or removed as applications dictate.

The Mobi-EVS boasts an array of thoughtfully integrated ergonomic features that seamlessly merge user comfort and operational efficiency. These features collectively empower mechanics to work more efficiently, minimizing fatigue and maximizing their overall output within the dynamic automotive workshop environment.



## Equipped To Take on EVS?

As the shift from gas engines to EV's grow, so does the need to safely handle the increased weight and EV-specific lifting points. Our newest 10AP two-post lift offers a generous 10,000 lb. lifting capacity, combined with newly patented Bi-Metric™ triple-telescoping arms that are perfectly suited for EV service and more. Super-strengthened arm restraints make sure the adjustable lift arms stay put.



Qualifying businesses can schedule an on-site demo to see just how amazing our Mobi-EVS system is, and how all of our best-in-class features set us apart from the competition.

**Call 1-800-253-2363** now to schedule an appointment, or visit **[bendpak.com/mobi-evs-demo](https://bendpak.com/mobi-evs-demo)**



**BENDPAK**



### 10AP Two-Post Lift

Certified to meet the standards of ANSI/ALI

Mobi-EVS™ EV4500

PATENT PENDING

### Elevate your EV Service Standards

BendPak's 10AP two-post lift, expertly paired with the Mobi-EVS. The 10AP provides a secure and adaptable platform for safely lifting electric vehicles, while the Mobi-EVS provides unmatched mobility and convenience for efficient and safe handling of EV battery packs and powertrains.

# FEATURES

---

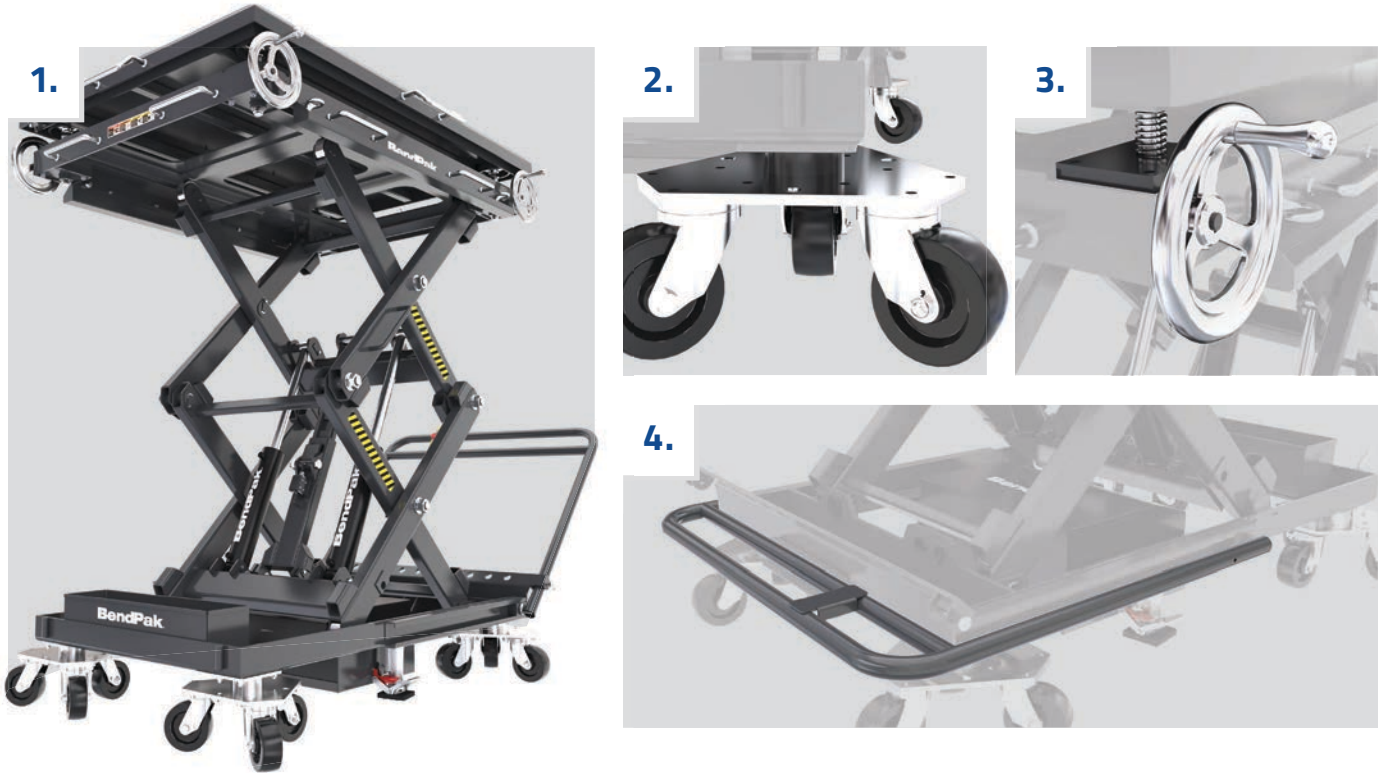

## 1 Built Smart, Built Tough, Built To Last

To ensure optimal portability, we meticulously engineered each Mobi-EVS to uphold its structural integrity in key areas, all while avoiding unnecessary steel usage. High-tensile steel used throughout skillfully marries minimal weight with exceptional safety standards making for a ruggedly built lifting system. A robust upper deck plate is further reinforced with supplementary structural crossmembers, strategically implemented to mitigate deflection resulting from torsion or uneven loading, even under demanding conditions.

## 2 Zero-Throw Casters for Extreme Maneuverability

Revolutionary turn-on-a-dime, zero-throw casters with oversized 5" diameter wheels allow the lift table to move and change direction effortlessly, requiring a fraction of the effort normally associated with plain swivel casters.

## 3 Adjustable Screw Jacks

Screw jacks allow for quick and easy service and provide effortless roll, pitch, and yaw adjustments for precise alignment and leveling of EV batteries, engine and drivetrain assemblies, fuel tanks, and more. This patented design minimizes time and effort spent making adjustments.

## 4 Stowable Push-Pull Handle

The stow-and-go handle provides a space-saving solution by allowing users to quickly stow the push-pull handle back into the lift, providing more workaround clearance. Wider push-pull handle mounts provide improved control.

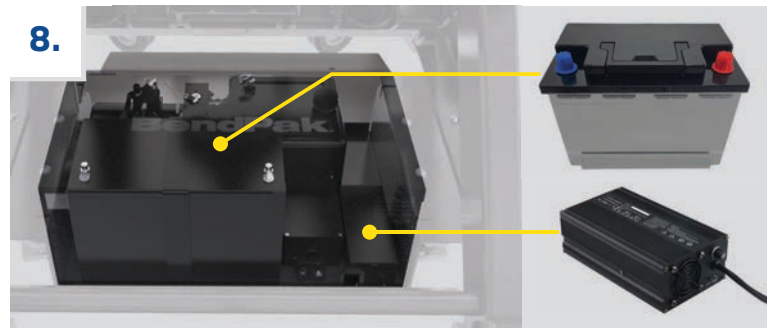
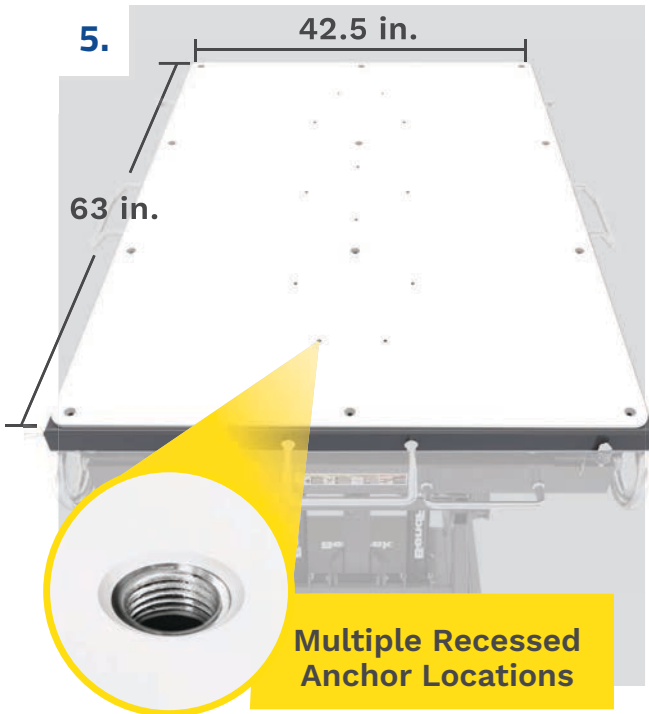

## 5 Optimum Versatility

The 42.5 in. x 63 in. lift platform is the perfect size for safe handling of heavy battery packs and powertrain systems. The platform surface features multiple recessed anchoring locations for accommodating a variety of modular fixtures, adapters, and accessories that can be repositioned or removed as applications dictate.

## 6 Twin Hydraulic Cylinders

Twin hydraulic cylinders feature welded construction, chrome-plated rods, and highly polished bores for extended seal life. Proprietary seal design reduces leakage and increases seal life for long-lasting, dependable operation.

## 7 Tri-Caster Locking Pin

It is easier than ever to move your Mobi-EVS longer distances. The removable locking pin located on the front tri-casters converts them into a fixed design making straight-line travel more efficient.

## 8 DC Electric Power System With Onboard Charger

Features a heavy-duty 12V DC power unit with deep cycle battery, an onboard battery charger, and battery charge indicator that accurately displays the charge condition of the lift battery at all times. The 12V, 15A microprocessor controlled, 4-stage automatic battery charger features connect and forget operation that helps protect the battery from being overcharged.



# FEATURES

---

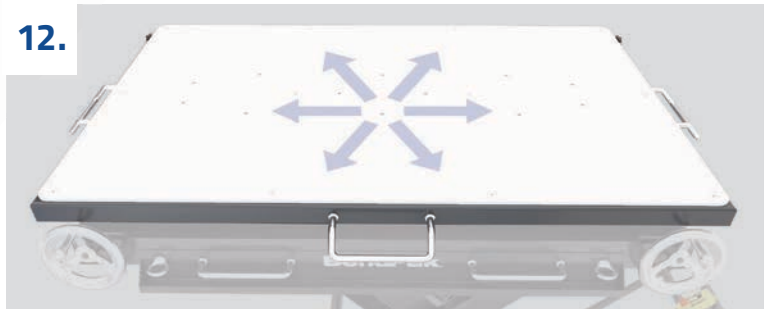
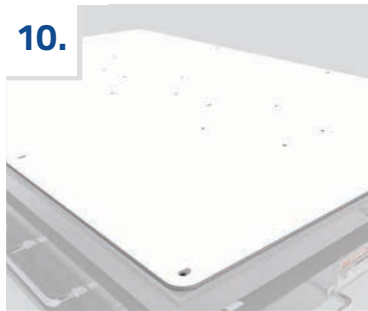

## 9 Multi-Point Safety Locks

Our Multi-Point Safety Lock system is designed to provide you with peace of mind and unmatched control, acting as a fail-safe sentry that engages automatically at all times during lifting operations. Features an electric-solenoid control that is readily available and easily disengaged with a simple button press on the pendant control.

## 10 Impact Resistant Protection

Ultra-High Molecular Weight (UHMW) Polyethylene platform surface is designed for optimal performance, offering exceptional impact resistance and low-friction finish. This specialized surface doubles as an effective insulation barrier, safeguarding electrical components by preventing any direct contact with the conductive steel platform surface.

## 11 Remote Control Operation

A standard hand pendant controller made of high-impact ABS plastic features an eight-foot lead, allowing convenient one-man control on all sides of the lift. An Emergency Stop shuts off power to the lift instantly with a simple push of a button.

## 12 Side-To-Side Adjustments Made Easy

An integrated slip-plate deck features low rolling resistance maintenance-free ball retainers and nylon bearings that enable effortless side-to-side shifting of the tabletop for even more adjustability and precise alignment.



## 13 Full-Length Utility Trays

Having all the necessities within easy reach can help increase productivity. All Mobi-EVS lifts feature full-length utility trays on both sides of the lift that provide ample storage for tools and fasteners.

## 14 Manual Floor Locks

Single-action tandem floor locks act as a parking brake when the lift is being loaded or used during EV service. Foot operation locks and releases easily with durable urethane bottom pads that offer maximum gripping power.

## 15 Precision Hydraulic Control

Ensuring smooth and precise operation, this specialized valve regulates the flow of hydraulic fluid within the lift's hydraulic system, allowing for controlled ascent and descent of the platform. This enables operators to manage the lift's speed and movement with accuracy, enhancing safety and usability.

## 16 Storage Bins

Two different storage bin options are the perfect place to store your most frequently used tools and adapters to help keep your work area better organized.



### Powder Coat Paint Finish

All Mobi-EVS models sport a durable baked-on powder coat finish that gives the metal a high-quality, sturdy finish which can withstand even the harshest environmental or chemical conditions.

# PRODUCT DETAIL

Model	EVS3000	EVS4500
SKU	5175611	5175613
Platform Capacity	3,000 pounds (1,361 kg)	4,500 pounds (2,041 kg)
Overall Length	91.25 in. (2,318 mm)	
Overall Length (Handle Stowed)	72.75 in. (1,848 mm)	
Overall Width (with Handle)	53 in. (1,348 mm)	
Platform Size	63 in. (1,600 mm) x 42.5 in. (1,088 mm)	
Max. Platform Height	77.75 in. (1,972 mm)	
Stowed Height	34.25 in. (868 mm)	
Raise / Lower Time (Max. Rise)	≈18 Seconds	
Power Source	12V Deep Cycle DC Battery	
Product Weight	1,918 lbs. (870 kg)	
Warranty	24-Months	

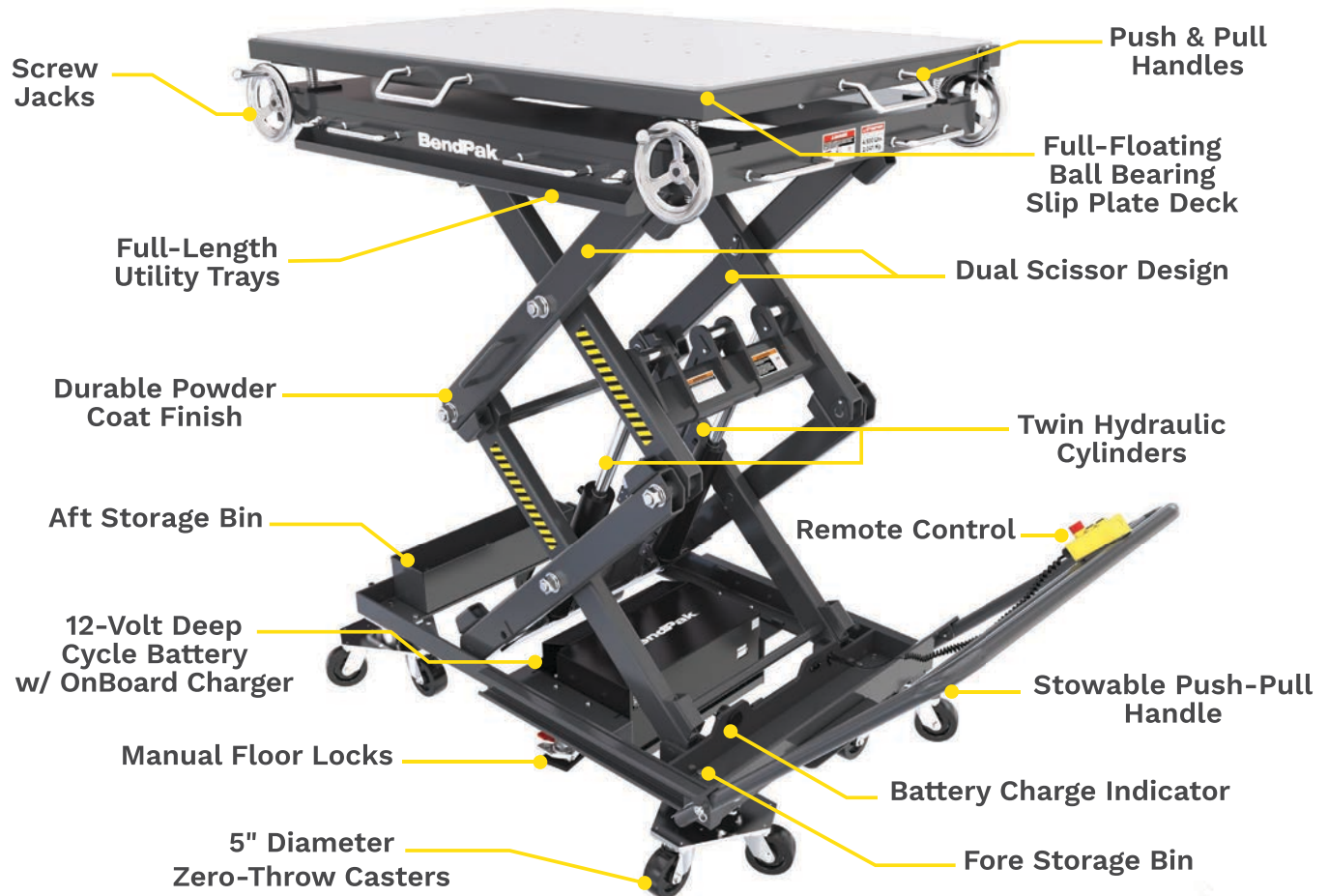

Specifications subject to change without notice. Photos and diagrams are shown for illustrative purposes only. BendPak makes no warranty, representation, or guarantee regarding the information contained herein or the suitability of this equipment for any particular purpose. Always refer to the operator's manual for detailed instructions on the proper use and maintenance.



## VERTICAL HEIGHT STAGING POSITIONS

### UP

77.75 in. (1,972 mm)

4 71.75 in. (1,825 mm)

3 63.5 in. (1,612 mm)

2 54.5 in. (1,386 mm)

1 44.75 in. (1,136 mm)

### DOWN

34.25 in. (868 mm)

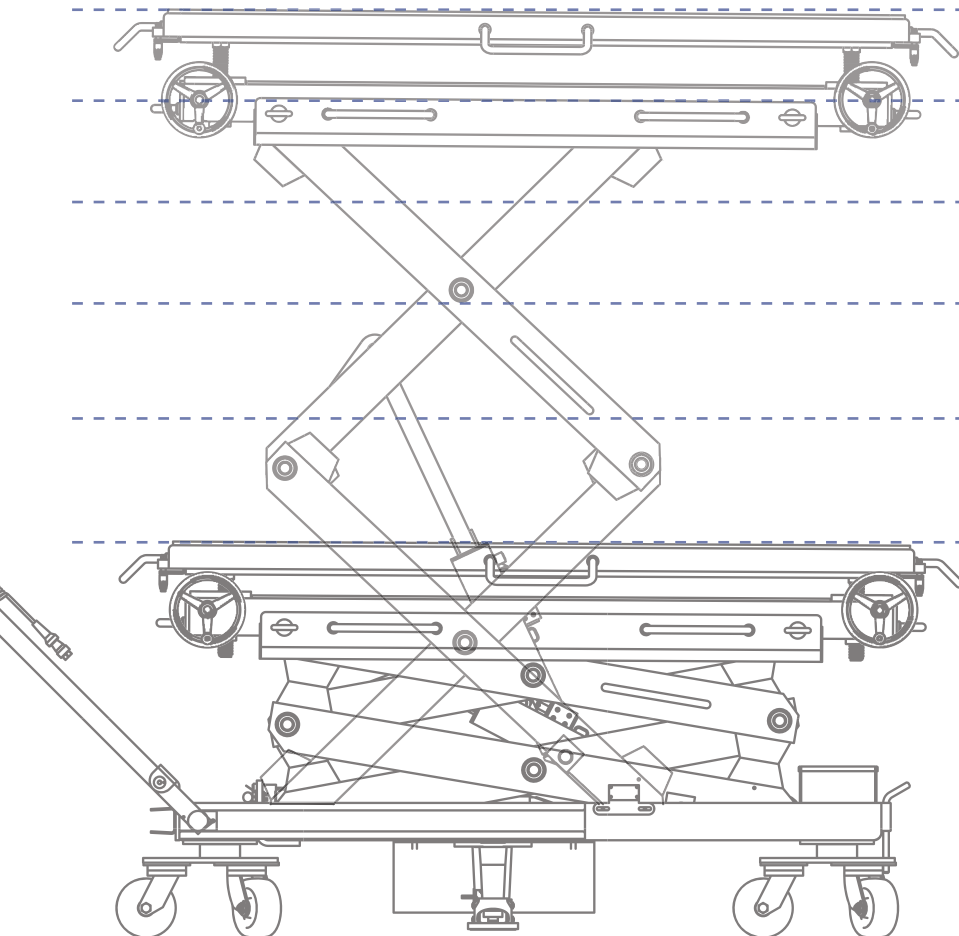

### Multiple Working Heights

Multi-Point Safety Locks positioned at different staging areas provide peace-of-mind and act as a fail-safe backup that engages automatically during component staging and lifting operations.

# ACCESSORIES

## EXPAND YOUR SERVICE CAPABILITY TO MEET GREATER DEMAND

Our line of Mobi-EVS electric-hydraulic lift tables feature recessed anchoring locations for accommodating a variety of modular fixtures, adapters, and accessories. Each can be repositioned or removed as applications dictate.



### Mobi-EVS Multi-Point Support Kit

SKU 5216205

The 4-point adapter set features independently adjustable indexing arms that adapt to nearly any transmission, drivetrain or vehicle subframe shape. The kit comes complete with four telescoping support tubes, four adjustable height contact pads, and four stackable adapters offering 800 lbs. capacity at maximum extension. Requires #5216234 Universal Deck Mount Kit.



### Mobi-EVS Universal Deck Mount Kit

SKU 5216234

The universal adapter plate features a center support pin that adapts to almost all transmission jack heads, drivetrain adapters, and fuel tank supports on the market. Required for #5323189 Transmission Support and #5216205 Multi-Point Support Kit.

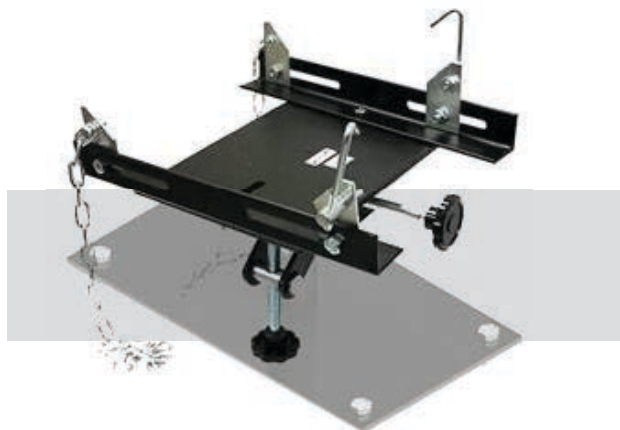

### Mobi-EVS Transmission Support

SKU 5323189

The transmission jack adapter is ideal for automotive or light truck transmission installation or removal. Bi-directional adjustable saddle adapts to most auto and light truck transmissions, transfer cases or differentials. Includes hold-down chains. Requires #5216234 Universal Deck Mount Kit.

## Mobi-EVS Telescoping Arm Kit

Set of 4 / SKU 5210454



The telescoping arm kit attaches easily to the lift deck, providing a multitude of support options. The kit comes complete with four telescoping lift arms, four adjustable height contact pads and four stackable adapters that provide multi-configurable support of large, heavy, and awkward vehicle components providing 600 lb. of capacity at each arm.

## Mobi-EVS Fixture Set

Set of 4 / SKU 5210458



These multi-adjustable Accu-Point™ support fixtures create a dynamic universal fitment that adapt to nearly any transmission, drivetrain or vehicle subframe shape. The kit comes complete with four adjustable support fixtures, four adjustable height contact pads, and four stackable adapters offering 600 lbs. capacity at each fixture.



# ELEVATE YOUR EV SERVICE

The combination of BendPak's 10AP two-post lift and the Mobi-EVS represents the epitome of enhanced EV service. The 10AP's robust construction and advanced features provide a secure platform for lifting electric vehicles, ensuring both safety and efficiency during maintenance. Its adaptable design accommodates various EV models, while the Mobi-EVS offers unparalleled mobility and convenience for safe and efficient handling of EV battery packs and powertrain systems. This dynamic-duo minimizes downtime and streamlines the service process, catering specifically to the unique demands of electric vehicles.

## 10AP Two-Post Lift & Mobi-EVS™



# RISE TO NEW HEIGHTS

Overall Height **145 in.**



SKU 5175304

### 10AP

The 10AP is our standard model that features 82.5" of max lifting height\* and an overall beam height of just 145" for shops with typical ceiling clearances.

Overall Height **168 in.**

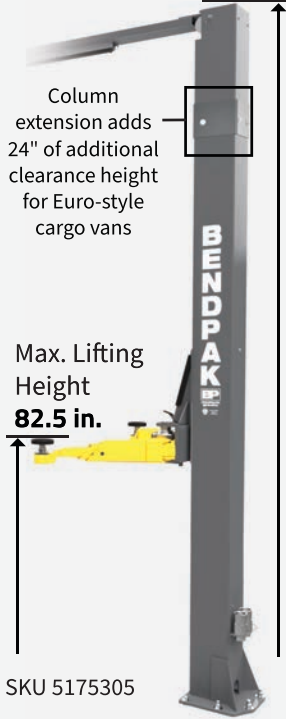

SKU 5175305

### 10AP-168

This model is the same as our 10AP, but comes equipped with an upper crossbar positioned two feet higher to accommodate high-profile vehicles. It features 82.5" of max lifting height\* and an overall beam height of 168".

Overall Height **157 in.**



SKU 5175306

### 10APX

The 10APX high-rise model is perfect for taller technicians who find it hard to work under normal-rise lifts. It features 89" of max lifting height\* and an overall beam height of 157".

Overall Height **181 in.**

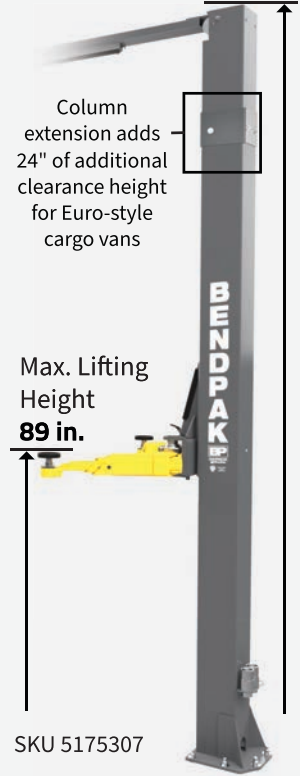

SKU 5175307

### 10APX-181

Like our 10APX, this high-rise model is perfect for taller technicians. It comes equipped with an upper crossbar positioned two feet higher and has an overhead beam height of 181".

\*Maximum Lifting Height is the maximum lifting height of lift with contact pads adjusted to high setting and with both tall and medium adapters installed (Sold Separately).

SKU 5900297