

The **APEX™ AB28** is built for professional shops that need consistent, vibration-free balance results, without paying for features that don't add real value. Designed as a dependable, no-nonsense wheel balancer, the **AB28** delivers commercial-grade accuracy, fast cycle times, and long-term reliability at a price point that makes sense for budget-conscious operations.

Capable of handling wheels up to 44 inches in diameter, the **AB28** is well suited for everything from passenger vehicles and light trucks to performance and specialty wheels. Backed by BendPak's engineering expertise and support infrastructure, it's a dependable balancing solution for one-bay shops, tire dealers, and high-volume service centers alike.

## Precision That Delivers Every Time

At the heart of the **AB28** is **APEX™** Digital Sensor Technology – engineered to deliver repeatable, accurate balance results down to hundredths of an ounce. Its direct-axis drive system ensures true, vibration-free rotation, allowing technicians to confidently balance today's OEM and aftermarket wheel designs with minimal rework.

In a fast seven-second cycle, the **AB28** calculates the precise amount and placement of corrective weight. Bright LED indicators guide technicians directly to the correct position, reducing guesswork and speeding up workflow.

## Advanced Digital Sensor Technology

The **AB28** uses an advanced digital signal processor paired with single-chip circuit architecture to improve processing speed, accuracy, and reliability. This design reduces latency, minimizes heat buildup, and increases long-term component life – critical advantages in high-use shop environments.

By consolidating processing into a single-chip platform, the **AB28** achieves faster data throughput and more stable measurement results, especially when performing advanced balancing techniques required for modern alloy and performance wheels.

## Multi-Directional Load Sensing

High-precision quartz piezoelectric load sensors measure imbalance forces in multiple directions, allowing the **AB28** to detect longitudinal, transverse, and shear forces simultaneously. These sensors offer exceptional sensitivity, long-term stability, and resistance to fatigue, resulting in consistent accuracy over years of daily use.

The rigid quartz sensor design enables high-frequency detection across all measurement axes, improving balance accuracy for challenging wheel and tire assemblies.



## Designed for Speed & Ease of Use

- **Quick, Damage-Free Wheel Mounting** – A full cone set and rubber-lined no-mar Quick-Nut system make wheel mounting fast and secure while helping protect expensive wheels from damage.
- **Comprehensive Mounting Cone Package** – Includes three automotive and light-truck cones (1.75”–2.75”, 2.75”–3.50”, 3.50”–4.25”) plus a larger truck cone (4.50”–5.00”) and spacer ring to handle a wide range of hub sizes.
- **Weight Optimization** – The **AB28** automatically calculates the minimum weight needed for proper balance, reducing weight usage, lowering consumable costs, and improving overall efficiency.
- **Graphic User Interface** – The intuitive touch-pad interface displays wheel and tire graphics that guide technicians through data entry and balance procedures quickly and accurately.
- **LED Rolling Weight Placement Indicators** – Bright LED indicators guide technicians as the wheel is rotated to top-dead-center, simplifying clip-on and tape-weight placement. Tiered indicators assist with split-weight and behind-the-spoke applications for clean, OEM-style results.

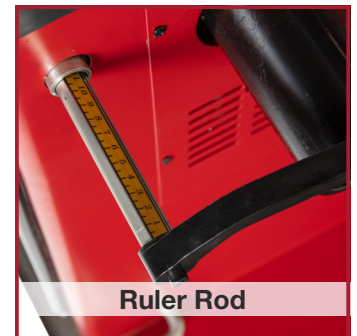
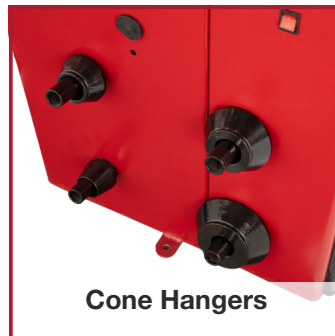

## Everything You Need to Get Up and Balancing Right Out of the Box.

The **APEX™ AB28** ships with a complete professional accessory package, eliminating the need for immediate add-ons or upgrades. From a full cone kit and BendPak-backed Quick-Nut system to essential measuring tools and service hardware, each included component is selected to maximize accuracy, efficiency, and wheel protection.

It's a turnkey balancing solution designed to minimize setup time, streamline daily operation, and deliver confident results from day one – another example of how **APEX™** and BendPak focus on real-world shop value.

## What's Included

- Calibration Weight
- Four-Piece Cone Kit (4 Cone)
- Truck-Cone Spacer Ring
- Quick-Nut System
- Quick Nut
- Quick Nut Cup
- Quick Nut Protective Cover
- Wheel Width Caliper
- Weight Removal Tool
- Weight Hammer / Pliers
- Allen Wrench
- Back Spring
- Anchor Bolts (M8 x 100 mm)

### Features at a Glance

- 1** Commercial-grade digital wheel balancer designed for daily shop use
  - Backed by BendPak engineering and support
- 2** Advanced Digital Sensor Technology for fast, repeatable balance accuracy
- 3** Multi-directional quartz piezoelectric load sensors for precise imbalance detection
- 4** Direct-axis drive system for smooth, vibration-free rotation
  - Fast seven-second balancing cycle improves workflow and throughput
  - Handles wheels up to 44" in diameter for passenger, light truck, and performance vehicles
  - Automatic weight optimization reduces weight usage and operating costs
- 5** LED rolling weight placement indicators guide precise clip-on and tape-weight placement
- 6** Static, dynamic, and performance alloy (ALU) balance modes
- 7** Graphic user interface with intuitive wheel and tire icons
  - Automatic braking after balance cycle complete
- 8** No-mar Quick-Nut system for fast, damage-resistant wheel mounting
- 9** Precision-machined 36 mm hardened steel shaft
  - Full cone and spacer kit included for a wide range of hub sizes
  - Self-calibration function maintains long-term accuracy
- 10** Large top tray and side storage for weights and tools



## SPECIFICATIONS

Motor	1.1KW / 110/220V 50/60HZ 1Ph.
Cycle time	6-9 seconds (avg.)
Balancing Modes	Dynamic / Static / 3-Alloy
Self-Calibration Function	Standard
Wheel Spin Braking	Automatic / Electronic
Wheel Holding	Manual Brake Pedal Standard
Cones Included	3 Standard / 1 Truck
Maximum Tire Diameter	44" / 1118 mm
Max Tire Weight	145 pounds (65 Kg)
Max. Wheel Diameter	12" - 28" / 305 mm - 711 mm
Wheel Width Capacity	4" - 15" / 102mm - 381mm
Balancing Increments	0.25 or 0.01 ounce
Balancing Speed	260 RPM
Accuracy	± 1 Gram / .035 Oz.
Noise	<70 dB

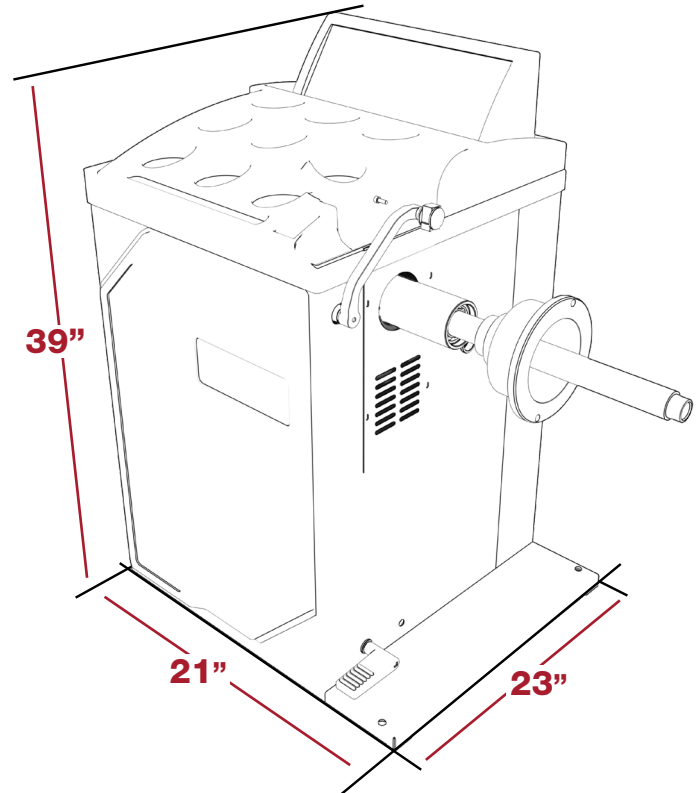

## Optional Productivity Accessories

### Pneumatic Wheel Lift (Optional)

SKU 5150593

Simplifies handling heavy truck and custom wheels, reducing technician fatigue and risk of injury. Smooth one-handed operation raises and positions wheels quickly for mounting.



### Motorcycle Shaft Kit (Optional)

SKU 5150320

Universal clamp kit accommodates Harley-Davidson, Japanese, and European motorcycle wheels with hub widths up to 9-1/2". Installs quickly on the 36 mm shaft.



### Flange Plate Kit (Optional)

SKU 5150020

Multi-position flange plate with lug-bolt adapters provides greater centering accuracy than cones alone – ideal for vibration-sensitive vehicles and performance applications.

