

---

# BendPak Technical Service Bulletin

## GP-9 and D4-9 Series – Small Spacer Orientation

### BendPak TSB 81 – 082021

The purpose of this Technical Service Bulletin is to describe the new orientation for the Small Spacer (P/N 5716049) currently not shown in the Installation Manual.

Affected Models: All GP-9 and D4-9 Series Four Post Lifts.

**What you need to do:** Rotate the Small Spacers so that the middle tabs are facing **away** from the Ladders on the Lift Post; one Small Spacer per each Lift Post.

Inserting the Spacers is performed when installing the Crosstubes. See Installation Manual for more details.

The following drawing shows the **old** and **new** orientation for the Small Spacer in the Crosstube Sleeve.

**Old:**

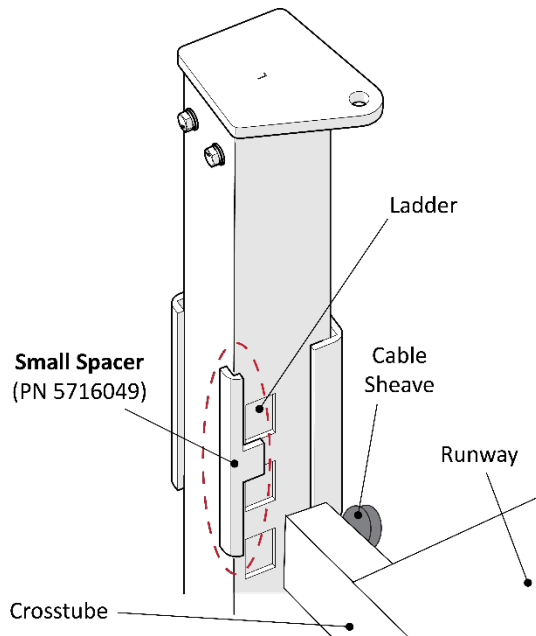

**New:**

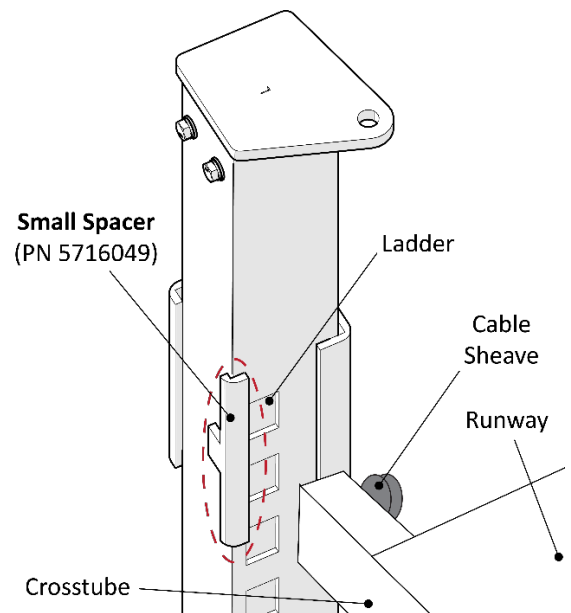

*Drawings not necessarily to scale. Some components removed for clarity.*

#### **Other Important Notes:**

- You **must** properly grease all lubrication points (where Cable Sheaves are located) with White Lithium Grease prior to operating the Lift to ensure that the Runways raise and lower smoothly.

If you have questions about your BendPak Four-Post Lift, go to [Bendpak.com/support](https://www.bendpak.com/support), email [support@bendpak.com](mailto:support@bendpak.com), or call **(805) 252-2363**.