

MORE

SPEED • HORSEPOWER • TORQUE

R745 Tire Changer

SKU# 5140148

SWING-ARM



1-800-253-2363 • www.BendPak.com

Ranger[®]

R745 Tire Changer

High-torque Electric Turntable

Featuring faster operating speeds and reverse-direction control for easier tire swaps, this tire changer reduces the risk of tire damage, especially for low-profile and run-flat beads that need time to relax.

Enhanced Bead Breaker Blade

The R745 tire changers are fit with an advanced bead breaker blade. Its durable construction ensures better mechanical strength, as well as many years of dependable service life. A rubber bump stop ensures a smooth arm return, lessening shock loading and minimizing any wear on the pneumatic cylinder. Other moving parts are also kept safe by the bump stop.

Forged Steel Foot Pedal Levers

All Ranger tire changers feature 100% forged steel foot pedals. This design makes the foot pedals remarkably lightweight, durable and non-reactive with chemicals, liquids and other inadvertent environmental elements.

Sealed Tight

Protecting the internal workings of your tire changer is first and foremost in our minds, so there's little to no component maintenance for you to worry about. Every main lead electrical terminal, auxiliary switch and motor enclosure is air tight, dust free and utterly safe from contamination.

High-Pressure Polyurethane Pneumatic Tubing

Our R745 tire changers come standard with high-pressure polyurethane pneumatic tubing that's constructed with a smooth, seamless bore to improve flow. The tire changer's tubing boasts a high abrasion resistance, as well as high burst tolerance and total kink resistance.

Specially Engineered Drive-Belt

The convex sidewalls on the R745's drive-belt evenly disperse wear. As a result, the tire changer itself lasts significantly longer in your shop due to the improved belt support. Flex bonded cords and flex weave covers keep away contaminants and pollutants, such as water and oil, as well as weather conditions that are out of your control.

Tire Inflator Features

A pistol-type tire inflator with a sure grip clip on valve chuck has never been easier to operate and permits full-function, hands free operation.

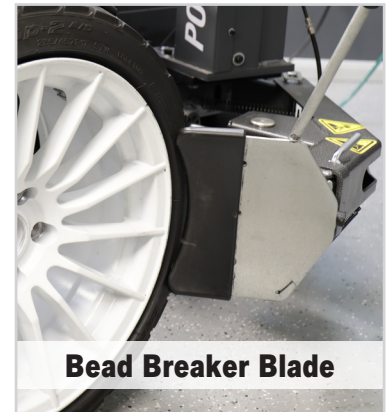



Maintenance-Free Gearbox

Ranger is proud to offer tire changers so well-constructed, you never have to service their gearboxes. The R745 tire changer is no different. Like our other models, it features an impressive oil and grease tank, which releases heat and better lubricates the components. Internal baffles work in conjunction with a constant-seating stress flange gasket to provide low temperatures though superior venting and zero fluid leakage.

Upfront Controls

We keep our tire changer controls upfront and logically arranged for both speed and ease-of-use.



Aluminum Pneumatic Cylinders

To keep machine vibration and friction levels low and extend the life of your tire changer, Ranger optimizes the stainless steel and aluminum pneumatic cylinders. Specifically, we've made sure internal end-of-stroke cushions come included on each cylinder, protecting the seals, wear band and piston rod. Each cylinder is continuously lubricated during use, further lengthening the life of your unit and strengthening our claim that Ranger makes the best tire changers in the world.

Alloy Steel Mount & Demount Head

The equi-dimensional shape of our mount and demount head lets you change tires without changing the position of the tool head. The tool head surface is manufactured micro-smooth, so mounting gliding tire beads into place is easy. Your tire changer is useless if it busts tires during routine operations, so our hardened alloy steel mount and demount head is specially designed to keep your tires safe at all times, even in the busiest shop environments.

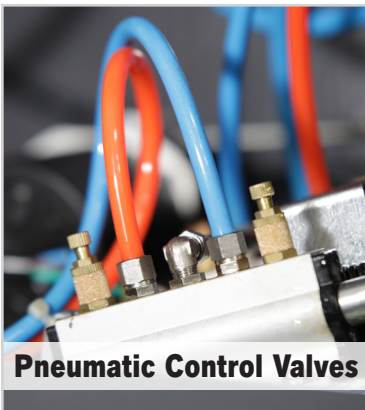

All The Extras Come Standard

A soap bucket and brush comes standard, along with turntable jaw covers, bead breaker blade boots and mount / demount head covers. Everything can be stored right in the tire changer itself, so you're not losing things, searching around the shop and ordering extras of what you think you've lost. To keep you swapping tires with the best of them, a steel tire iron and bead lever tool comes included with your purchase.



45mm Spring Assist Hexagonal Vertical Tool Shaft

A rigid 45 mm spring assist hexagonal vertical tool shaft and hardened steel horizontal outrigger support arm keep the mount-demount tool head perfectly still during operations. This all but ensures you won't damage expensive wheels due to a loose or shifting tool head. The tire changer is fitted with linear guide bearings that make it easy to adjust both the vertical and horizontal wheel settings. These guide bearings are completely maintenance-free for the entire lifespan of your tire changer. The non flex horizontal arm boasts a hardened lower roller guide for controlled, balanced movements.

Plenty Of Storage

Keep your shop clean, calm and ready for anything. Your tire changer has enough storage to hold all provided tools and accessories, as well as other items you want nearby while you work.

R745 FEATURES



STANDARD ACCESSORIES

Alloy Mount / Demount Head



Lubricator Bucket & Brush



Tire Iron

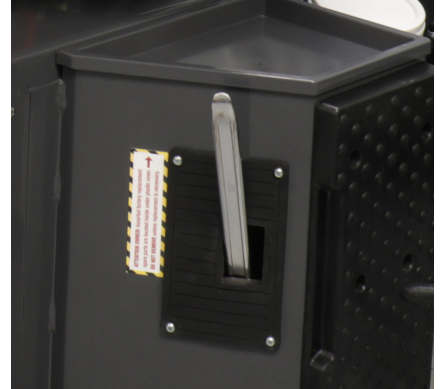

OPTIONAL ACCESSORIES

Plastic Tool Head

#5150523



- Helps protect expensive alloy wheels
- Must have mount-demount head flange adapter. Not included.

Wheel Protection Kit

#5150585



- (3) roller replacement inserts
- (3) mount-demount head underside slides
- (4) turntable clamp covers
- (2) bead breaker blade covers

Mounting Flange

#5150524



- Hardened steel
- Includes all mounting hardware
- Requires plastic tool head

Elevated Clamp Adapters

#5327861



- Perfect for motorcycle and ATV wheels
- Increases external wheel clamping capacity 4"

SPECIFICATIONS

Model	R745 Swing-Arm
Voltage	110V, 50-60 Hz, 1 Ph*
Min. Air Source Requirements	15 CFM, 165 PSI
Inside Wheel Clamping Range	12" - 20" (305 mm - 508 mm)
Outside Wheel Clamping Range	10" - 16" (254 mm - 407 mm)
Turntable Tire Width Capacity	5" - 12" (127 mm - 305 mm)
Maximum Tire Diameter	39" (991 mm)
Dimensions	33" (965 mm) W x 39" (1,232 mm) D x 70" (1,930 mm) H

*Note: Standard electrical configurations shown. Additional voltage options available upon request.

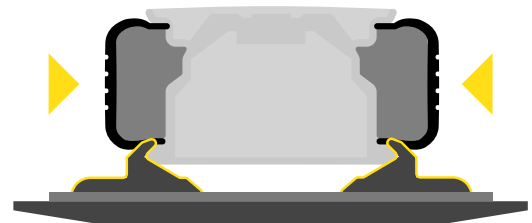
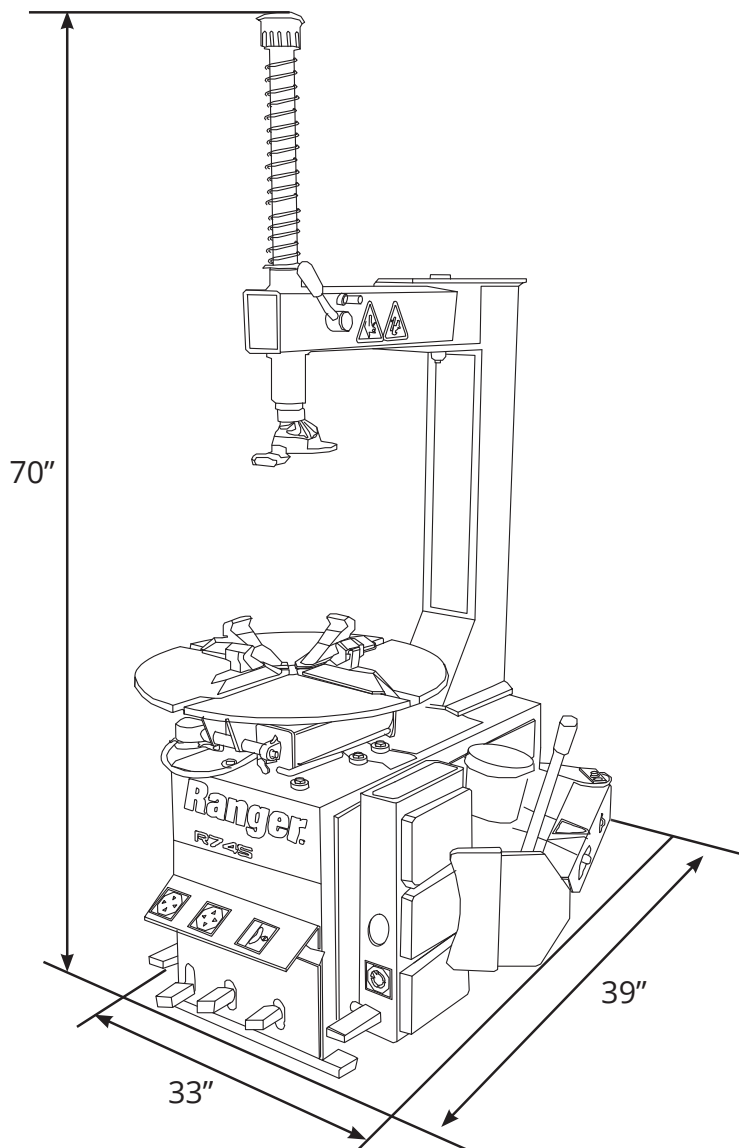

Outside Wheel Clamping Range

10 - 16" (254 - 407 mm)

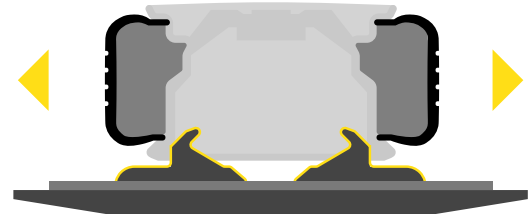

Inside Wheel Clamping Range

12 - 20" (305 - 508 mm)



Maximum Tire Diameter

39" (991 mm)

Disclaimer: Specifications, features, and options are subject to change without notice. Illustrations may show optional equipment or accessories sold separately. Maximum wheel sizes, weights, and capacities are approximate and may vary depending on wheel type, condition, and application. Always follow manufacturer guidelines and local safety regulations when operating equipment.