



# AL10C

2-Post Lift / 10,000-lb. Capacity

SKU# 5176251

## THE ULTIMATE BLEND OF PERFORMANCE, SAFETY, AND VERSATILITY

Engineered for professional shops and home garages alike, the Apex AL10C delivers the perfect combination of power, reliability, and efficiency. With a 10,000-lb. lifting capacity, this two-post lift is designed to handle everything from compact cars to full-size trucks. Its symmetric and asymmetric lifting capabilities provide flexible arm positioning, allowing you to work with ease on a variety of vehicle makes and models.

The clearfloor design eliminates the obstructive floor beam found in traditional two-post lifts, providing unrestricted movement beneath the vehicle. This makes it easier to maneuver tool carts, transmission jacks, oil drains, and other shop equipment without interference. Whether you're working on low-profile sports cars or lifted trucks, the open floor space ensures better clearance and a more efficient, clutter-free workspace.



## PRECISION LIFTING WITH UNMATCHED FLEXIBILITY

Positioning a vehicle correctly on a two-post lift can be frustrating, but the AL10C eliminates the guesswork with advanced lifting features. Triple-telescoping front arms and dual-stage extended rear arms offer exceptional reach, accommodating a wide range of vehicles. The included double-telescoping screw pads and 4-piece stackable adapter set ensure secure, stable contact with every lift, no matter the frame design.

## BUILT FOR SAFETY AND STABILITY

The AL10C is equipped with automatic safety locks that engage every three inches, ensuring rock-solid security throughout the lift range. The trouble-free locks release effortlessly via single-pull lanyards on each carriage, providing maximum safety without unnecessary complexity.

Rugged box-beam overhead structure reinforces the lifting frame, reducing stress on the columns and enhancing stability. For added protection, a padded overhead shutoff bar, paired with an industrial-grade limit switch, acts as a safeguard—stopping the lift if a vehicle is raised too high. For added security, automatic arm restraints secure the arms in place when the lift is raised, preventing unintended movement during service.

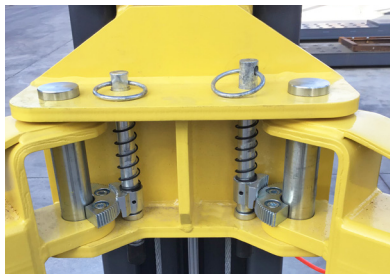

## HEAVY-DUTY STRENGTH YOU CAN RELY ON

Built to withstand daily use in demanding shop environments, the AL10C is constructed with high-strength steel and reinforced components. A 6" x 6" tubular steel carriage provides superior load-bearing capability, while the electric-hydraulic power system ensures quiet, efficient operation. For added stability, oversized 20.5" x 15.5" base plates help distribute weight more effectively, making it a lift you can depend on for years to come.

## LOW MAINTENANCE, HIGH PERFORMANCE

Unlike many full-column clearfloor lifts that use complex chain-over systems, the AL10C features a direct-drive design with tubular steel carriages paired with dual full-stroke hydraulic cylinders. This proven setup delivers smooth, consistent lifting with significantly fewer moving parts. By minimizing wear and reducing maintenance needs, it ensures long-term reliability and superior performance.

To further extend the life of critical components, the lift features self-lubricating UHMW polyethylene guide blocks, eliminating the need for messy greasing. Oversized cable sheaves reduce cable fatigue, while aircraft-quality 3/8-inch equalizer cables evenly distribute weight, ensuring a balanced lift every time.

## 36-MONTH WARRANTY FOR PEACE OF MIND

When you invest in the Apex AL10C, you're backed by BendPak's industry-leading 36-month warranty, covering structural components and craftsmanship. With BendPak's renowned customer support and a nationwide network of service providers, expert assistance is always within reach.

## OFTEN IMITATED, NEVER DUPLICATED

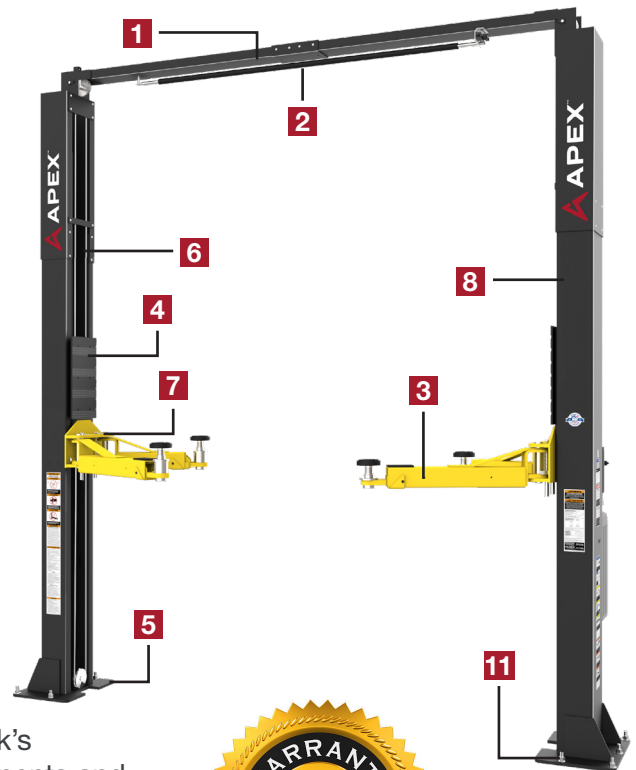

## FEATURES

- 10,000-lb. lifting capacity
- 1** Rugged box-beam overhead construction for added stability
- 2** Padded overhead safety shutoff bar
  - Symmetric and asymmetric arm design for enhanced versatility
- 3** Triple-telescoping front arms & dual-stage extended rear arms
  - Dual direct-drive low-pressure hydraulic cylinders
- 4** Heavy-duty 6" x 6" tubular steel carriage for maximum strength
  - Electric-hydraulic power system for effortless operation
- 5** Oversized 20.5" x 15.5" base plate for increased stability
  - Self-lubricating UHMW polyethylene guide blocks for long-lasting durability
- 6** Safety locks in each column spaced every 3 inches
- 7** Automatic arm restraints for enhanced safety
- 8** Heavy-duty 3/8" aircraft-quality equalizer cables
  - Oversized cable sheaves to reduce cable fatigue
- 9** Double-telescoping screw pads feature tear-resistant polyurethane for long-lasting durability
  - Full size rubber carriage guard reduces door dings
- 10** 4-piece 63mm stackable adapter set included
- 11** 10-piece concrete wedge anchors included
  - 36-month limited warranty

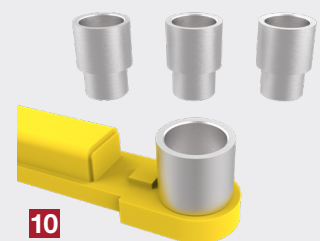

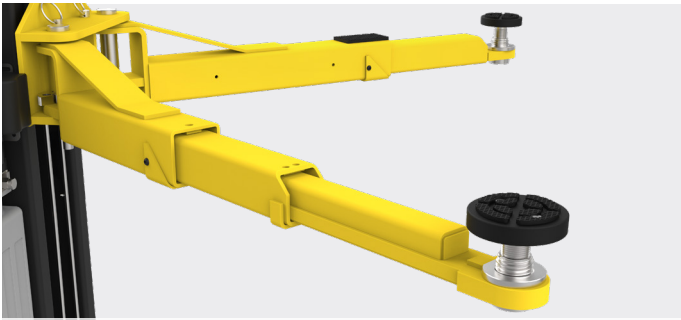

**Triple-Telescoping front arms & dual-stage extended rear arms**

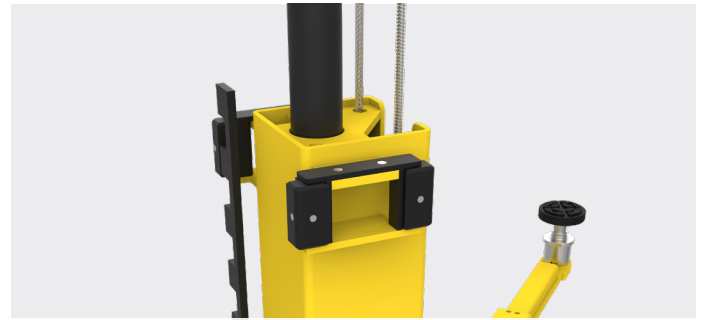

**Heavy-Duty 6" x 6" tubular steel carriage for maximum strength**

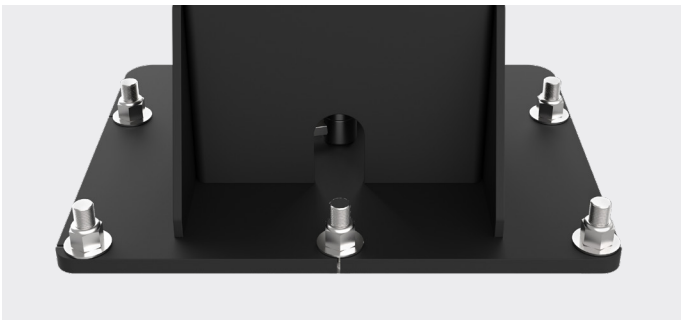

**Oversized 20.5" x 15.5" base plates for increased stability**



**Automatic arm restraints for enhanced safety**

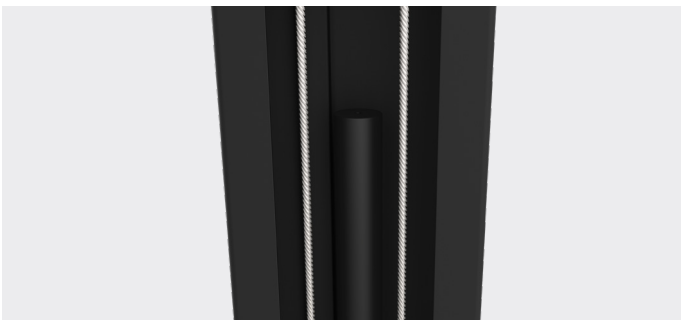

**Direct-drive design features dual full-stroke hydraulic cylinders**

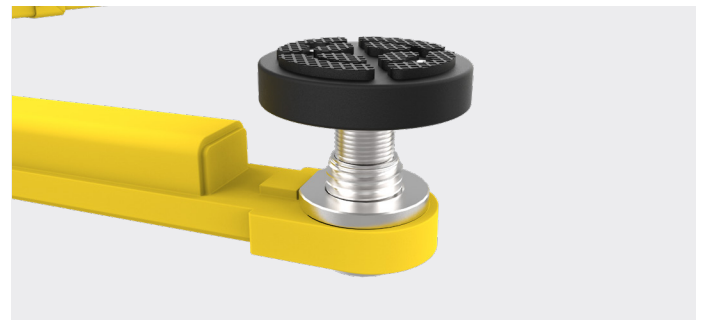

**Double-telescoping screw pads feature tear-resistant polyurethane non-slip pads**



**4-piece 63mm stackable adapter set included**

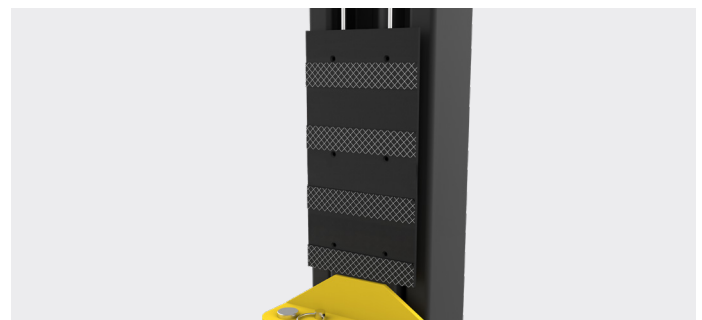

**Full size rubber carriage guard reduces door dings**

### SPECIFICATIONS

MODEL	AL10C
Lifting Capacity	10,000 lbs. (4,536 kg)
Max. Capacity / Front Axle	5,000 lbs. (2,268 kg)
Max. Capacity / Rear Axle	5,000 lbs. (2,268 kg)
<b>A</b> - Height Overall (*)	148" (3,759 mm)
<b>B</b> - Width Overall (at Baseplate)	137.5" (3,492 mm)
<b>C</b> - Width Outside of Columns	128.5" (3,264 mm)
<b>D</b> - Floor To Overhead Switch Bar	142.5" (3,619 mm)
<b>E</b> - Width Inside Columns	114.5" (2,908 mm)
<b>F</b> - Front Arm Reach (Min.)	22.5" (571 mm)
<b>F</b> - Front Arm Reach (Max.)	43.25" (1,099 mm)
<b>G</b> - Rear Arm Reach (Min.)	33.5" (845 mm)
<b>G</b> - Rear Arm Reach (Max.)	53.25" (1,353 mm)
<b>H</b> - Min. Pad Height	3.9" (100 mm)
<b>I</b> - Rise	70" (1,778 mm)
<b>J</b> - Max. Lift H. (Pad + 63mm Adapt.)	76.5"-78.5" (1,943-1,994mm)
<b>K</b> - Drive-Thru Clearance	103" (2,618 mm)
Screw Pad Adjustment	2" (51 mm)
Motor (**)	220 VAC / 60Hz / 1 Ph
Time of Full Rise	65 seconds
Max. Load Per Arm	2,500 lbs. (1,134 kg)
Shipping Weight	1,545 lbs. (703 kg)

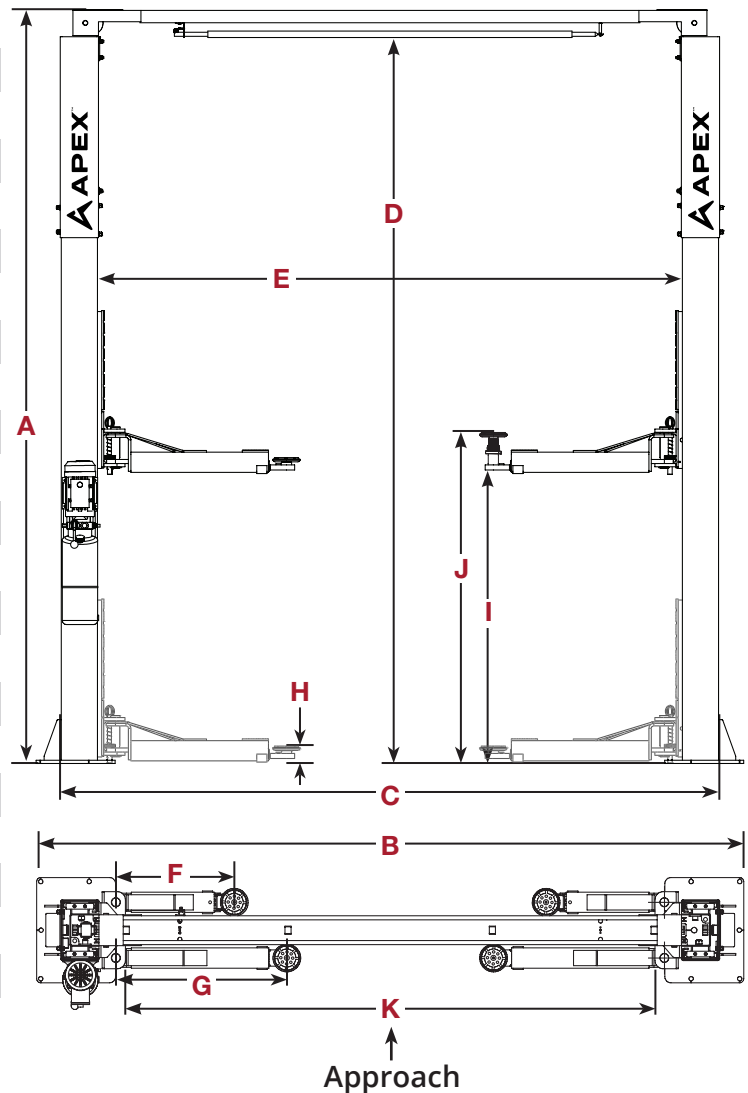

\* To top of cylinder when lift is raised to max height.

\*\* Special voltages available upon request.

The design, material and specifications are subject to change without notice.

#### DISCLAIMER

Apex by BendPak makes no promises, guarantees, or assurances that this product meets any state, county, federal, or international mandated permit, license, code, standard, certification, or any other mandate, including the standards prescribed by ANSI/ALI ALCTV-(current edition) or ANSI/UL 201. Consult [www.autolift.org](http://www.autolift.org) for a complete list of lift models that meet ANSI/ALI ALCTV-(current edition) or ANSI/UL 201, or contact BendPak via [contact@bendpak.com](mailto:contact@bendpak.com).

Buyer assumes full responsibility for any state, county, federal, or international mandated permit, license, code, standard, certification, or any other requirement related to the installation and/or operation of this product. Apex by BendPak will not be responsible for any charges, fines, liens, or other levies imposed on the Buyer related to any special or regional structural, seismic, or other building codes, including but not limited to the Uniform Building Code (UBC), International Building Code (IBC), or any other state, county, federal, or international mandated permit, license, code, standard, certification, or directive issued by any agency, government, administration, or corporation.

#### OPTIONAL ACCESSORIES



**Frame Cradle Pads  
Set of 4** SKU 5210573



**Tall Adapters  
Set of 4** SKU 5210535

### UPGRADE YOUR SHOP TODAY!

Don't waste time with outdated, high-maintenance lifts. The AL10C is designed for efficiency, strength, and reliability, making it the perfect choice for professional mechanics, performance tuners, and serious DIYers.

Order now at [BendPak.com](http://BendPak.com) and experience the Apex difference!