

Swing Arm Tire Changer

Installation and Operation Manual

Manual P/N 5900158 — Manual Revision F2 — January 2023

Models:

- R980XR
- R980AT
- R980AT-L



R980XR



R980AT

Designed and engineered in Southern California, USA. Made in China.

 **DANGER**

Read the *entire contents* of this manual *before* using this product. Failure to follow the instructions and safety precautions in this manual can result in serious injury or death. Make sure all other operators also read this manual. Keep the manual near the product for future reference. *By proceeding with setup and operation, you agree that you fully understand the contents of this manual and assume full responsibility for product use.*

Manual. R980XR and R980AT Swing Arm Tire Changers, *Installation and Operation Manual*, Manual P/N 5900158, Manual Revision F2, Released January 2023.

Copyright. Copyright © 2023 by BendPak, Inc. All rights reserved. You may make copies of this document if you agree that: you will give full attribution to BendPak Inc., you will not make changes to the content, you do not gain any rights to this content, and you will not use the copies for commercial purposes.

Trademarks. BendPak, the BendPak logo, Ranger, and the Ranger logo are registered trademarks of BendPak Inc. All other company, product, and service names are used for identification only. All trademarks and registered trademarks mentioned in this manual are the property of their respective owners.

Limitations. Every effort has been made to have complete and accurate instructions in this manual. However, product updates, revisions, and/or changes may have occurred since this manual was published. BendPak Ranger reserves the right to change any information in this manual without incurring any obligation for equipment previously or subsequently sold. BendPak Ranger is not responsible for typographical errors in this manual. You can always find the latest version of the **manual for your product on the Ranger website**.

Warranty. The BendPak Ranger warranty is more than a commitment to you: it is also a commitment to the value of your new product. For full warranty details, contact your nearest BendPak Ranger dealer or visit bendpak.com/support/warranty. Go to bendpak.com/support/register-your-product/ and fill out the online form to register your product (be sure to click **Submit**).

Safety. Your new product was designed and manufactured with safety in mind. Your safety also depends on proper training and thoughtful operation. Do not set up, operate, maintain, or repair the unit without reading and understanding this manual and the labels on it; **do not use this product unless you can do so safely!**

Owner Responsibility. In order to maintain your product properly and to ensure operator safety, it is the responsibility of the product owner **to read and follow these instructions**.

- Follow all installation, operation, and maintenance instructions.
- Make sure product installation and operation conforms to all applicable local, state, and federal codes, rules, and regulations, such as state and federal OSHA regulations and electrical codes.
- Read and follow all safety instructions. Keep them readily available for operators.
- Make sure all operators are properly trained, know how to safely operate the unit, and are properly supervised.
- Do not operate the product until you are certain that all parts are in place and operating correctly.
- Carefully inspect the product on a regular basis and perform all maintenance as required.
- Service and maintain the unit only with approved replacement parts.
- Keep the manual with the product and make sure all labels are clean and visible.
- **Only use this product if it can be used safely!**

Unit Information. Enter the Model Number, Serial Number, and the Date of Manufacture from the label on your unit. This information is required for part or warranty issues.

Model: _____

Serial: _____

Date of Manufacture: _____

MODEL NO.	R980AT
SERIAL NO.	12345-678-910
REVISION	REV.B/3HP
DATE OF MFG.	03/19
VOLTAGE	220V, 50Hz/60Hz



 **DANGER!**
Disconnect Power
Before Servicing.

Ranger Products™
1645 Lemonwood Drive • Santa Paula, CA 93060
www.rangerproducts.com
ENGINEERED BY RANGER PRODUCTS USA • MADE IN CHINA

Table of Contents

Introduction	3	Operation	26
Shipping Information	4	Maintenance	55
Safety Considerations	4	Troubleshooting	58
Components	6	Wiring Information	59
FAQ	8	Labels	60
Specifications	9	Parts	63
Installation Checklist	10	Maintenance Log	87
Installation	11		

Introduction

This manual describes the following models in the R980 Swing Arm Series of Tire Changers:

- **R980XR.** 3 HP, 220 VAC Tire Changer; no Assist Tower.
- **R980AT.** 3 HP, 220 VAC, Tire Changer with Assist Tower.
- **R980AT-L.** 2 HP, 110 VAC, Tire Changer with Assist Tower.

More information about BendPak Ranger products is available at the [BendPak Ranger website](#).

This manual is mandatory reading for all users of the R980 Series of Tire Changers, including anyone who sets up, operates, maintains, or repairs them.

You can always find the latest version of the **manual for your product on the BendPak Ranger website**.

 DANGER Be very careful when setting up, operating, maintaining, or repairing this equipment; failure to do so could result in property damage, product damage, injury, or (in very rare cases) death. Make sure only authorized personnel operate this equipment. All repairs must be performed by an authorized technician. Do not make modifications to the unit; this voids the warranty and increases the chances of injury or property damage. Make sure to read and follow the instructions on the labels on the unit.

Keep this manual on or near the equipment so that anyone who uses or services it can read it.

Technical support and service for your Tire Changer is available from your distributor or by calling **BendPak Ranger at (805) 933-9970**. You may also call regarding parts replacement (please have the serial number and model number of your unit available).

Shipping Information

Your equipment was carefully checked before shipping. Nevertheless, you should thoroughly inspect the shipment **before** you sign to acknowledge that you received it.

When you sign the bill of lading, it tells the carrier that the items on the invoice were received in good condition. **Do not sign the bill of lading until after you have inspected the shipment.** If any of the items listed on the bill of lading are missing or damaged, do not accept the shipment until the carrier makes a notation on the bill of lading that lists the missing or damaged goods.

If you discover missing or damaged goods **after** you receive the shipment and have signed the bill of lading, notify the carrier at once and request the carrier to make an inspection. If the carrier will not make an inspection, prepare a signed statement to the effect that you have notified the carrier (on a specific date) and that the carrier has failed to comply with your request.

It is difficult to collect for loss or damage after you have given the carrier a signed bill of lading. If this happens to you, file a claim with the carrier promptly. Support your claim with copies of the bill of lading, freight bill, invoice, and photographs, if available. Our willingness to assist in helping you process your claim does not make us responsible for collection of claims or replacement of lost or damaged materials.

Safety Considerations

Read this manual carefully before using your new product. Do not set up or operate the product until you are familiar with all operating instructions and warnings. Do not allow anyone else to operate the product until they are also familiar with all operating instructions and warnings.

 **WARNING** There are many moving parts on a Tire Changer; keep clear of these moving parts and the Tire being changed. In particular, when inflating a Tire, never lean over the Tire; if it were to explode (which does happen), the force could injure or kill the Operator or bystanders. During inflation, the Operator should be as far away from the Tire as possible, and all bystanders must be at least 30 feet away.

Safety Information

Please note the following:

- The product is a Tire Changer. **Use it only for its intended purpose.**
- The product **must** only be operated by authorized, trained, properly supervised personnel. Keep children and untrained personnel at least 30 feet away from the product when it is in use.
- Always follow all applicable local, state, and federal codes, rules, and regulations, including (but not limited to) OSHA standard 1910.177 (Servicing multi-piece and single piece rim wheels).
- You **must** wear OSHA-approved (publication 3151) personal protective equipment at all times when installing, using, maintaining, or repairing the Tire Changer: leather gloves, steel-toed work boots, eye protection, back belts, and hearing protection **are mandatory.**
- Keep hair, loose clothing, jewelry, fingers and all body parts away from moving parts. Avoid pinch points.
- Be careful to not touch hot parts; you could be burned.
- Unplug the unit when not in use, if not hard wired into the electrical system.
- Do not use the product while tired or under the influence of drugs, alcohol, or medication.

-
- Do not use the product in the presence of cigarette smoke, dust, or flammable liquids or gases. Use the product indoors in a well-ventilated area.
 - Do not make any modifications to the product; this voids the warranty and increases the chances of injury or property damage. **Do not modify any safety-related features in any way.**
 - Make sure all Operators read and understand this *Installation and Operation Manual*. Keep the Manual near the device at all times.
 - Make a visual inspection of the product every day. Do not use the product if you find any missing or damaged parts. Instead, take the unit out of service, then contact an authorized repair facility, your distributor, or **BendPak Ranger at (805) 933-9970**.
 - BendPak Ranger recommends making a **thorough** inspection of the product once a month. Replace any damaged or severely worn parts, decals, or warning labels.

Symbols

Following are the symbols that may be used in this manual:



DANGER

Calls attention to a hazard that **will** result in death or injury.



WARNING

Calls attention to a hazard or unsafe practice that **could** result in death or injury.



CAUTION

Calls attention to a hazard or unsafe practice that could result in personal injury, product damage, or property damage.

NOTICE

Calls attention to a situation that, if not avoided, could result in product or property damage.



Tip

Calls attention to information that can help you use your product better.

Liability Information

BendPak Ranger assumes **no** liability for damages resulting from:

- Use of the equipment for purposes other than those described in this manual.
- Modifications to the equipment without prior, written permission from BendPak Ranger.
- Injury or death caused by modifying, disabling, overriding or removing safety features.
- Damage to the equipment from external influences.
- Incorrect operation of the equipment.

Components

The following image identifies the main components of the Tire Changer.

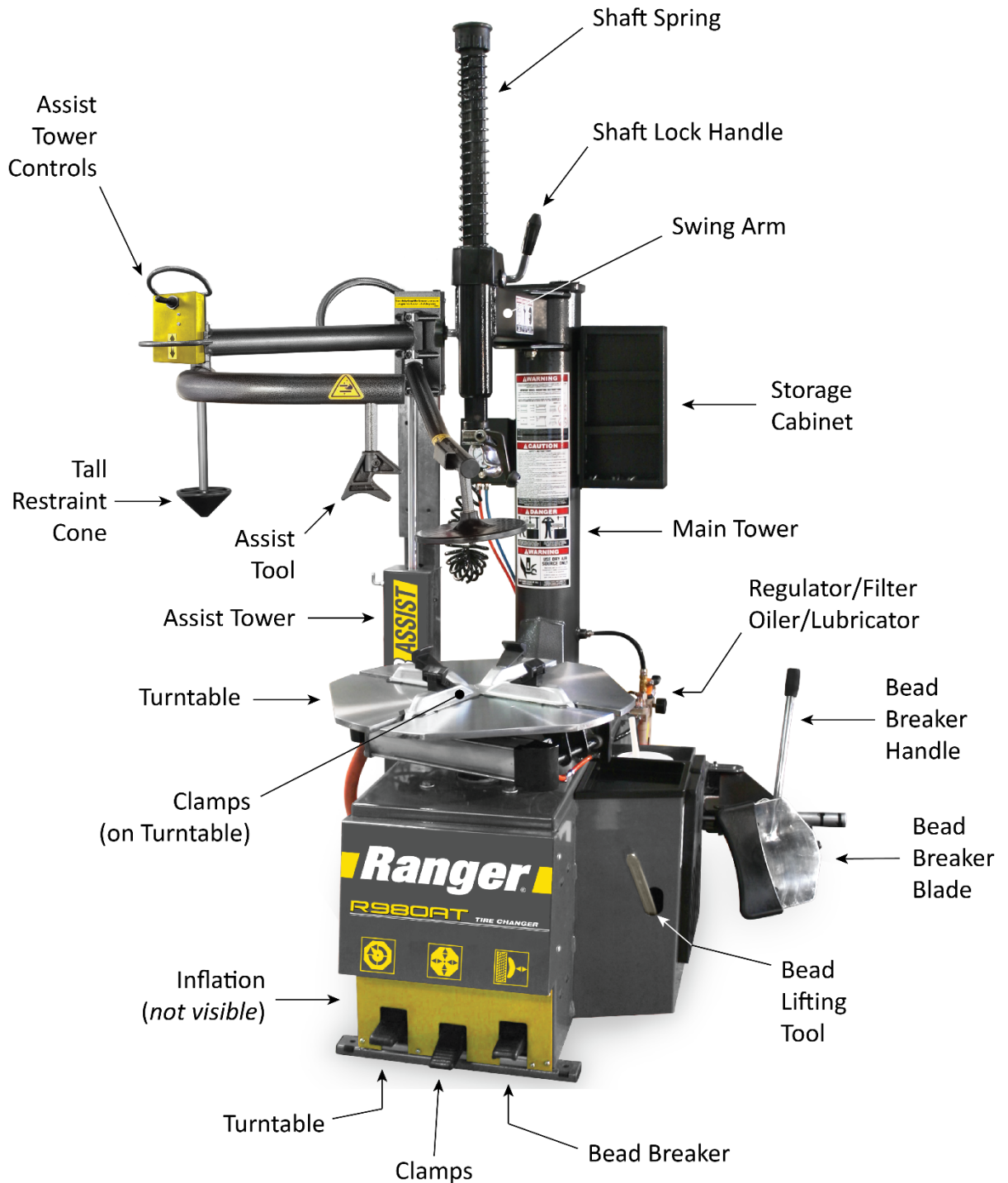

R980AT shown; the R980XR is not equipped with an Assist Tower, but may be ordered and installed separately. (See *Installing the Assist Tower* in this manual.) Not all components visible.

Tire Changer components include:

- **Turntable.** Holds the Wheel.
- **RimGuard™ Wheel Clamps.** Durable, hardened plastic Clamps do not damage expensive Wheels as they hold the Wheel in place.
- **Main Tower.** Holds the Swing Arm.
- **Swing Arm.** Holds the main tool, the Mount/Demount Head.
- **Mount/Demount Head.** Located on the end of the Swing Arm, the Mount/Demount Head is used to both mount and demount Tires. The Tire Changer comes with two Mount/Demount Heads, one alloy-steel (with roller) and one plastic polymer.
- **Shaft.** Moves the Mount/Demount Head up and down.
- **Shaft Lock Handle.** Locks the Mount/Demount Head in the desired position.
- **Bead Breaker.** Used to break the Beads of Tires before you demount them. Located on the right side of the Tire Changer. Includes a Handle, a Blade, and an adjustable mechanism for pushing the Blade inwards to break the Bead.
- **Bead Lifting Tool.** Basically, a Tire Iron that you use to pull the Bead edge of a Tire (whose Bead has been broken) over the Mount/Demount Head so the Tire can be demounted from the Wheel. Can also be used to hold down a Tire Sidewall during Tire mounting.
- **Assist Tower.** R980AT only. Holds several additional tools that can be used during mounting and demounting. Needs to be lubricated for easy movement of those components. Once lubricated, **do not lean on, or touch the Post** or you will get grease on you.
- **Restraint Cone.** Used to hold the Wheel in place during inflation. One short, one long provided; they slip on and off, just pull hard.
- **Assist Tool.** Holds the Sidewall of a Tire down during mounting.
- **Helper Disc.** Holds up the Tire so it can be demounted.
- **Assist Tower Controls.** Raises and lowers the Assist Tower Arms.
- **Inflation Gauge.** Shows the amount of air pressure currently in a Tire or the amount of air pressure in a Tire as the Tire is inflated. Includes an Air Chuck with self-gripping clip, so you do not have to hold the Air Chuck in place as you inflate a Tire.
- **Turbo-Blast™ Bead Sealer.** Directs a burst of air pressure to help seal a difficult Bead.
- **Clamps Foot Pedal.** Moves all four Clamps. Press **down** to move the Clamps in, press **up** to move the Clamps out.
- **Inflation Foot Pedal.** Controls putting air into a Tire.
- **Turntable Foot Pedal.** Rotates the Turntable. Press **down** to rotate the Turntable clockwise, press **up** to rotate the Turntable counterclockwise.
- **Regulator/Filter and Oiler/Lubricator.** Control and route the incoming air supply.
- **Storage Cabinet.** For storing things, you want to have nearby.

Tire Changer accessories include:

- **Lube Bucket.** For your Tire lubricant. Only use a lubricant approved by the Tire manufacturer for the Tire being changed.
- **Lube Brush.** To spread your Tire lubricant.
- **Extra Air Line Parts.** Provided in case they are needed in the future.
- **Extra Yellow Plastic Pieces.** Provided in case they are needed in the future.

Frequently Asked Questions

Question: What does a Tire Changer do?

Answer: A Tire Changer takes Tires off of Wheels (called demounting) and puts Tires onto Wheels (called mounting).

Q: What is the difference between a Tire, Wheel, and Rim?

A: A Wheel is the round **metal** piece that attaches to the Vehicle's axle. A Tire is the round **rubber** piece that surrounds the Wheel. The outer edge of the Wheel, where the Tire attaches to the Wheel, is called the Rim. Some people use Wheel and Rim interchangeably.

Q: What are the steps in the process of demounting a Tire and then mounting a new Tire?

A: The steps are: Deflate the Tire, break the Bead, secure the Wheel on the Turntable, demount the Tire, mount the new Tire, inflate the new Tire, then remove the Wheel from the Turntable.

Q: What does "break the Bead" mean?

A: A Tire is held on the Rim of a Wheel by the Tire Bead sitting between the Rim Lip and the Bead Retainer of the Rim. The air pressure in the Tire holds it in place once the Bead is seated (during mounting). When you "break the Bead", you move the Tire Bead out of the location where it was seated, which is required to take the Tire off of the Wheel.

Q: Can I break the Bead without fully deflating the Tire?

A: No, do not do this. **Always fully deflate a Tire before attempting to break its Bead.** The air pressure energy in a Tire, even if not fully inflated, can be considerable. If you were to attempt to break the Bead of a Tire not fully deflated, that air pressure energy would be released all at once, possibly injuring or, in rare cases, killing the Operator or bystanders.

Q: What thing should I always do when working with the Tire Changer?

A: You must match Rim Width with the Tire you are mounting. The result of a mismatch is that the Tire could literally explode off the Wheel when you inflate it or while the Vehicle is being driven. In both cases, people could be injured or killed.

Q: Where should I put my Tire Changer?

A: What you want is a flat Concrete floor with room around it that is also near where you work on Tires. Ideally, you want it a little off the beaten path, as you must – for safety – keep everyone away from the Tire Changer while it is in use. No one other than the Operator should be within 30 feet of the Tire Changer while it is in use.

Q: Why isn't there a plug on the end of the Power Cord?

A: 220 VAC plugs vary by region, so if you are going to use a Power Cord with Plug, you need to use a Plug that is appropriate for the power outlet you will be using. The other power option is to wire the Tire Changer directly into the facility's power system. You **must have** a licensed Electrician perform all electrical work in accordance with all applicable electrical codes.

110 VAC units are prewired with a plug.

Specifications

Model	R980AT	R980XR
Motor 220 VAC	3 HP, 208-240 VAC, 50-60 HZ, 1 Ph	
Motor 110 VAC (980AT-L)	2 HP, 110 VAC, 50-60 Hz. 1 Ph.	
Power Cord Length	96 in (8 feet) / 2,438 mm	
Drive System Type	Electric / Air	
Air Requirement	140 – 165 PSI (9.6 – 11.4 BAR)	
Wheel Clamping	4 Clamps – Internal / External	
Table Clamping	Dual Pneumatic Cylinders	
Bead Breaking	Pneumatic Blade / Dual	
Tower Design	Rigid Fixed / Swing Arm	
Assist Tower	Single Assist Tower	No Assist Tower
Bead Sealing	Turbo Blast	
Internal Rim Clamping	10 – 30 in (254 – 762 mm)	
External Rim Clamping	9 – 28 in (229 – 711 mm)	
Turntable Tire Width Capacity (Mounting)	4 – 18 in (102 – 457 mm)	
Bead Breaker Tire Width Capacity (Demounting)	1.5 – 13 in (38 – 330 mm)	
Maximum Tire Diameter	50 in (1,270 mm)	
Sound	<70 dB	
Dimensions R980AT	76.5 in. wide by 46 in. deep by 82 in. high 1,943 mm wide by 1,168 mm deep by 2,083 mm high	42 in. wide by 46 in. deep by 82 in. high* 1,067 mm wide by 1,168 mm deep by 2,083 mm high*

*The R980XR dimensions are without the optional Assist Tower.

Specifications subject to change without notice.

Installation Checklist

Following are the steps needed to install the Tire Changer. Perform them in the order shown.

- 1. Review the installation Safety Rules.
- 2. Make sure you have the necessary Tools.
- 3. Find an appropriate Location.
- 4. Make sure there is adequate Clearance around and above.
- 5. Unpack the Unit.
- 6. Install the Swing Arm Tower, Turbo Blast, Bead Breaker and make air connections.
- 7. Install the Toolbox and Inflation Gauge.
- 8. Install the Assist Tower (R980AT Only)
- 9. Remove the Tire Changer from the shipping pallet.
- 10. Move the Tire Changer to its to work location.
- 11. Connect to facility Power. ***Requires a licensed Electrician.***
- 12. Connect to facility Air.
- 13. Prepare the Lube Bucket.
- 14. Grease the Assist Tower Post.
- 15. Test the Tire Changer.
- 16. Review the Final Checklist.

Installation

This section describes how to install your Tire Changer. Perform the tasks in the order presented.

Installation Safety Rules

Pay attention at all times during installation. Use appropriate tools and equipment. Stay clear of moving parts. Keep hands and fingers away from pinch points. ***Safety is your top priority.***

Use caution when unpacking the Tire Changer from its shipping container and setting it up. The Tire Changer is heavy, and the weight is not evenly distributed; dropping or knocking over the unit may cause equipment damage and personal injury.

⚠ WARNING You ***must*** wear OSHA-approved (publication 3151) personal protective equipment at all times when installing, using, maintaining, or repairing the Tire Changer: leather gloves, steel-toed work boots, eye protection, back belts, and hearing protection.

Only experienced, trained technicians may install the Tire Changer. In particular, all electrical work ***must*** be done by a licensed, certified Electrician.

⚠ CAUTION Certain parts of installing the Tire Changer are difficult for just one person. BendPak Ranger ***strongly*** recommends having two or more persons work together to install the unit.

Tools

You may need some or all of the following tools:

- Forklift, pallet jack, or shop crane
- Utility knife
- Hammer, mallet, crowbar, or pry bar
- Tin or sheet metal snips
- Hex key and wrench set, metric, and SAE
- Screwdriver set, slot and Phillips

Additional supplies you may need:

- Teflon Tape or liquid PTFE thread sealant
- Anchor Bolts (Optional)
- Air fitting (Air In) to connect the Tire Changer to the shop compressed air supply.

Finding a Location

Keep the following in mind when deciding on a location:

- **Power source.** The Tire Changer needs to be near an appropriate power source.
- **Floor.** The Tire Changer is best used on a flat, Concrete floor.
- **Clearance.** The Tire Changer requires space around it. Refer to **Clearance** for more information.
- **Accessibility.** You need some space to move the Wheels and Tires to and from the Tire Changer.
- **Danger.** When a Tire is on the Tire Changer, especially during Inflation, you need to keep everyone far away from it; only the Operator should be within 30 feet of the Tire Changer when it is in use.

Do not set up the Tire Changer in a well-travelled area.

- **No water.** The Tire Changer has electrical components. If the Tire Changer gets wet while power is applied, those electronic components will most likely short circuit and have to be replaced.

⚠ WARNING Do not use the Tire Changer if it is sitting in water. You will almost certainly short circuit the electronic components in the Tire Changer and you could electrocute yourself or bystanders.

Clearance

A certain amount of space around the Tire Changer is required.

You also need room **above** the Tire Changer. BendPak Ranger recommends leaving at least an additional 12 inches / 305 mm of open space **above** the highest point of the Tire Changer.

⚠ WARNING The Clearance values shown below allow enough space to operate the Tire Changer. ***For safety purposes, only the Operator should be within 30 feet of the Tire Changer while it is in use.***

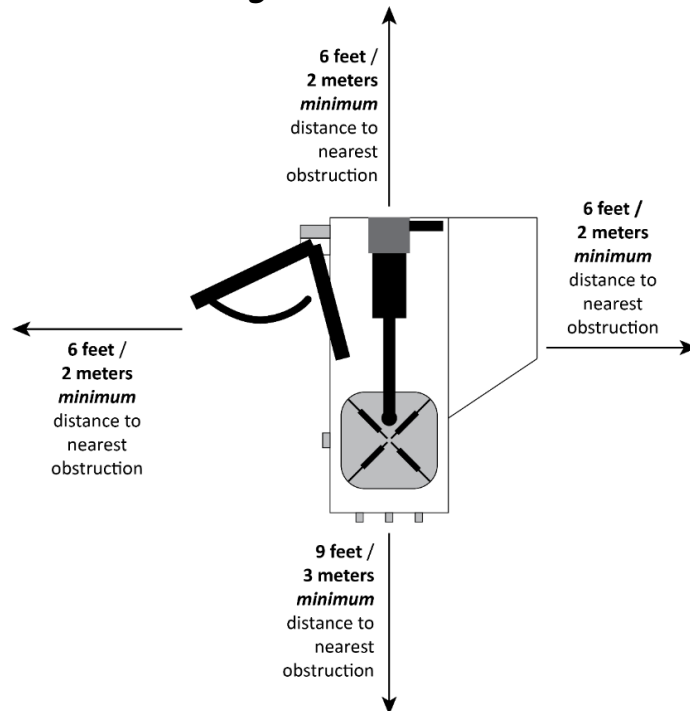

Top view. Not to scale.

Unpacking

Use caution when taking the Tire Changer out of its shipping container. You do not want to damage the unit, misplace any of the components, or cause injury.

⚠ WARNING Make sure to use an appropriate lifting device, such as a Forklift or Pallet Jack, to move the Tire Changer while it is on its Pallet. Make sure only personnel who are experienced with material handling procedures are allowed to move the Tire Changer. The Tire Changer is heavy, and the weight is not evenly distributed; dropping or knocking over the unit may cause equipment damage or personal injury. BendPak Ranger recommends having at least two people work together to move the Tire Changer.

We recommend unpacking the Tire Changer near where you are going to set it up.

⚠ WARNING You **must** wear OSHA-approved (publication 3151) Personal Protective Equipment at all times when installing the Lift: leather gloves, steel-toed boots, eye protection, back belts, and hearing protection are **mandatory**.

To Unpack the Tire Changer:

1. The Tire Changer is attached to a pallet and protected with a thin wood cover. At the bottom of the cover, use a pry bar or screwdriver to push the metal tabs all the way down, on all four sides.

You may have to apply some force to get all the metal tabs free; they sometimes stick. Refer to the figure on the right.

2. Rotate the cover off and set aside.

⚠ CAUTION Ranger recommends having at least two people lift the cover off; it is heavy and awkward. If it is dropped or falls, it could cause injury or equipment damage.

3. Carefully remove the plastic protecting the Tire Changer and retain any parts located in bubble wrap or plastic bags
4. Remove the Accessory and Fasteners boxes, Bead Breaker Blade, and Turbo Blast Hose. Set aside where they will not be damaged.

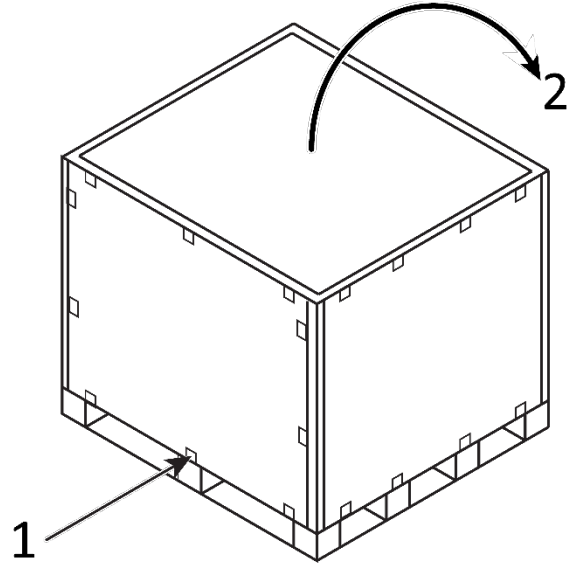

Installing the Swing Arm Tower and Components

The Tower/Swing Arm, Inflation Gauge and Bead Breaker come uninstalled from the factory. You need to remove them from where they are secured on the shipping pallet and install on the Tire Changer Cabinet.

To install the Tower:

1. Make sure you are wearing OSHA-approved (publication 3151) Personal Protective Equipment: leather gloves, steel-toed work boots, back belts, hearing protection, and ANSI-approved eye protection (safety glasses, face shield, or goggles). Wear gloves and keep rags nearby to clean up excess grease.

⚠ CAUTION Ranger recommends having at least two people handle the Assist Tower and the Main Tower. They are heavy and awkward to move. If either Tower is dropped or falls, it could cause injury or equipment damage.

2. Retrieve the three M12 x 60 Hex Head Bolts and M12 flat washer from the Accessories and Fasteners box.
3. Cut the straps securing the Assist Tower to the Pallet and Tire Changer Cabinet.
4. With the help of an assistant, carefully move the Assist Tower aside.
5. The Swing Arm Main Tower is secured to the shipping pallet in several locations. **Carefully** remove the Bolts that secure the Tower to the Shipping Pallet.
6. Cut the strap that secures the Main Tower to the Changer Cabinet.
7. Remove and retain the Bolt used to secure the strap to the Swing Arm of the Tower.

⚠ WARNING Use care when moving the Tower; it is heavy and not evenly balanced. If it is dropped, you could injure yourself, and damage the unit.

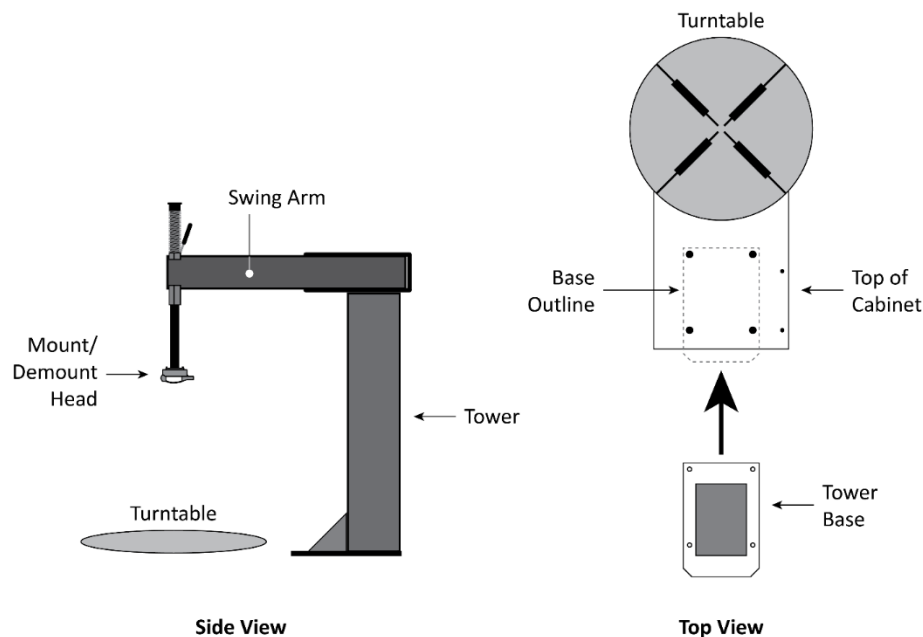
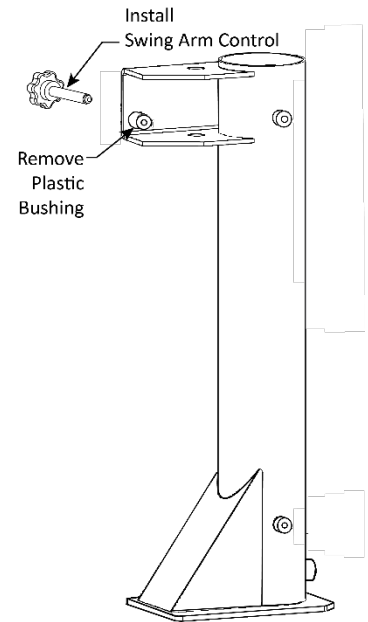

⚠ CAUTION Ranger recommends having at least two people handle the Assist Tower and the Main Tower. They are heavy and awkward to move. If either Tower is dropped or falls, it could cause injury or equipment damage.

8. With the help of an assistant, stand the Main Tower up on its base.
9. Using a Shop Crane or an Assistant carefully move the Main Tower onto the top of the Changer Cabinet. Move the Tower Base over the Tire Changer Cabinet, lining up the four holes in the Base over the four large holes in the top of the Cabinet. Make sure to orient the Tower so that the Mount/Demount Head is over the Turntable.
10. Use the four Bolt/Washer pairs M12 x 60 and M12 flat washer to securely bolt the Tower into position on top of the Cabinet.
11. Retrieve the Turbo Blast Hose Assembly.
12. Apply Teflon Tape to the threaded joint where it connects to the Main Swing Arm Tower.
13. Connect the Turbo Blast Hose Assembly (730-1) to the Main Tower using the Moveable Joint (746). Take care to not lose or damage the O-Rings in this joint. Refer to Figure 6.

Turbo Blast Connection

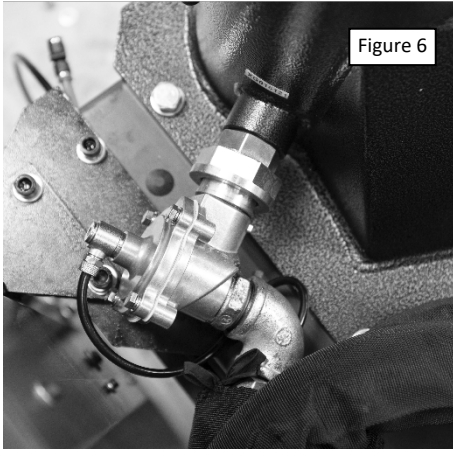

Not to scale, components removed for clarity

Installing the Assist Tower and Arms

1. Remove the bolt holding the Tire Changer to the pallet on its rear quarter.
2. Locate the Parts Box and remove the Tower Bracket Weldment (852) the Lower Support Bracket (858) and the following fasteners.

Qty.	Description
4	M8 x 30mm SHCS
4	M8 Split-Ring Lock Washer
4	M8 cover
2	M10 x 50 SHCS
5	M10 x 30 SHCS
7	M10 Split-Ring Lock Washer
7	M10 Flat Washer
2	M10 Hex Nut

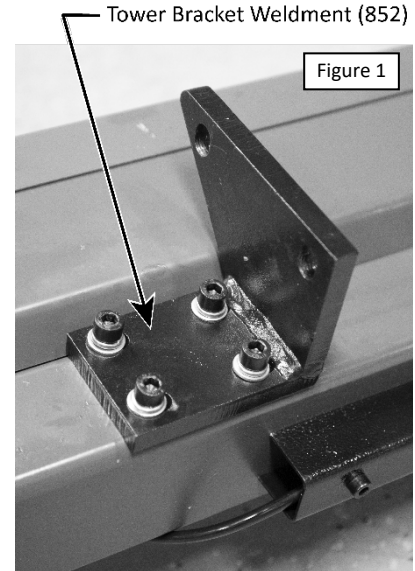

3. Install the Tower Bracket Weldment (852) on the Assist Tower using four M8 x 30 SHCS, split-lock washers, and flat washers. Refer to Figure 1.
4. Install the Lower Support Bracket (858) on the Main Cabinet using three M10 x 30 SHCS, split-lock washers and flat washers. Refer to Figure 2.
5. Remove the protective packing from the Assist Tower.
6. Use a shop crane or have an assistant move the Tower with its Arms into position on the Lower Support Bracket (858).
7. Place two M10 x 50 SHCS through the Tower Bracket Weldment (852) and the Chassis Bracket (892) bolted to the top of the Cabinet and secure finger tight with flat washer, split-ring lock washers and M10 Hex Nuts. Refer to Figure 3.

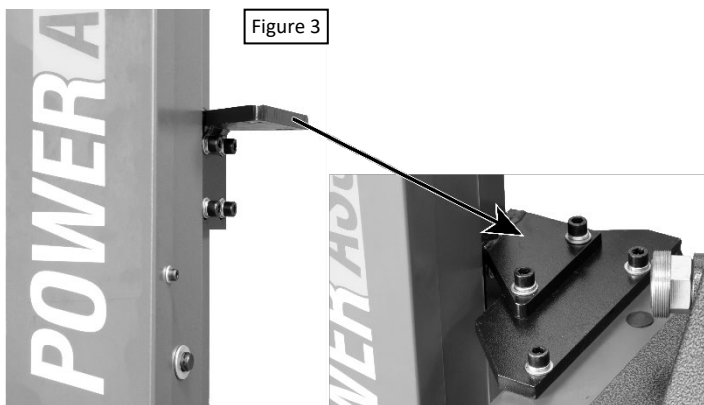
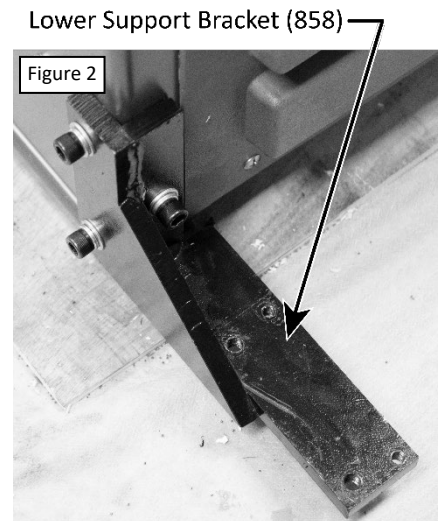

8. Insert two M10 x 30 SHCS, split-ring lock washers and flat washers through the Assist Tower Base and thread into the Lower Support Bracket (858) make finger tight. Refer to Figure 4.

9. Insert two M8 x 30 SHCS, splitting lock washers and covers through the Assist Tower Base and thread into the Lower Support Bracket (858).
10. Tighten all fasteners. Remove the Shop Crane, if required.

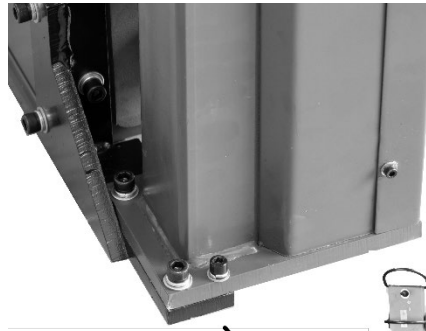
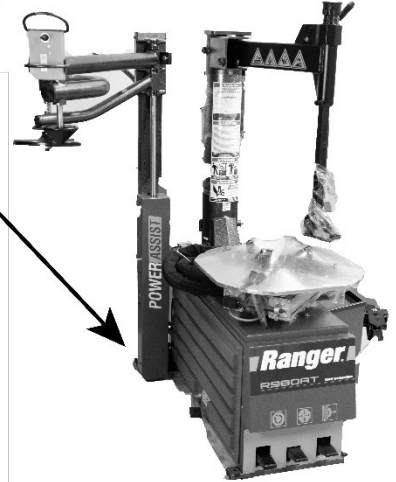
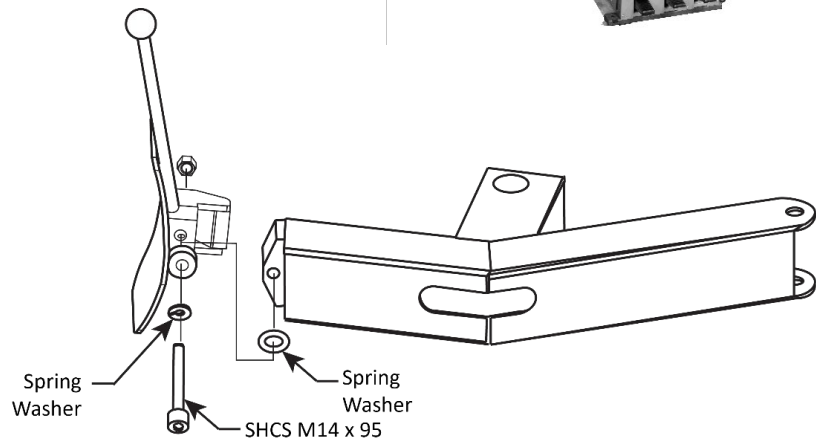

Figure 4



Install the Bead Breaker:

1. Retrieve the Bead Breaker Blade from its plastic bag.
2. Remove the M14 x 95mm Bolt, lock washer, and Lock Nut.
3. Insert the Bead Breaker Blade on to the Bead Breaker Arm and secure with the M14 Bolt, lock washer and Nut just removed. Refer to figure below.



Not to scale, not all components shown.

Connecting to Air Pressure

The Tire Changer requires a 15 to 25 CFM Air Source with an operating air pressure of 140 to 165 PSI (9.6 to 11.4 bar).

Important: The Tire Changer uses pneumatic and electrical energy; if your organization has Lockout/Tagout policies, implement them once the unit is connected to the Air Source.

The Air Lines routed out of the Regulator/Filter and Oiler/Lubricator come connected on the R980AT and ready for use; no installation or adjustment is required. On the R980X the Dry Air Out must be connected to the Tower Tank as shown in the photo to the right.

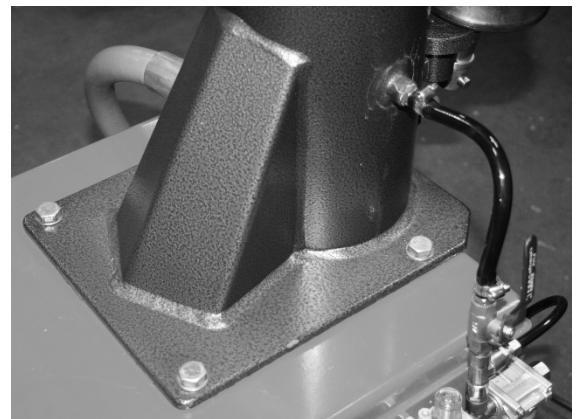

The incoming Air Source connects to the Tire Changer via the Air In connector on the Regulator/Filter. You need to provide a fitting for the Air In connector; it is not supplied.

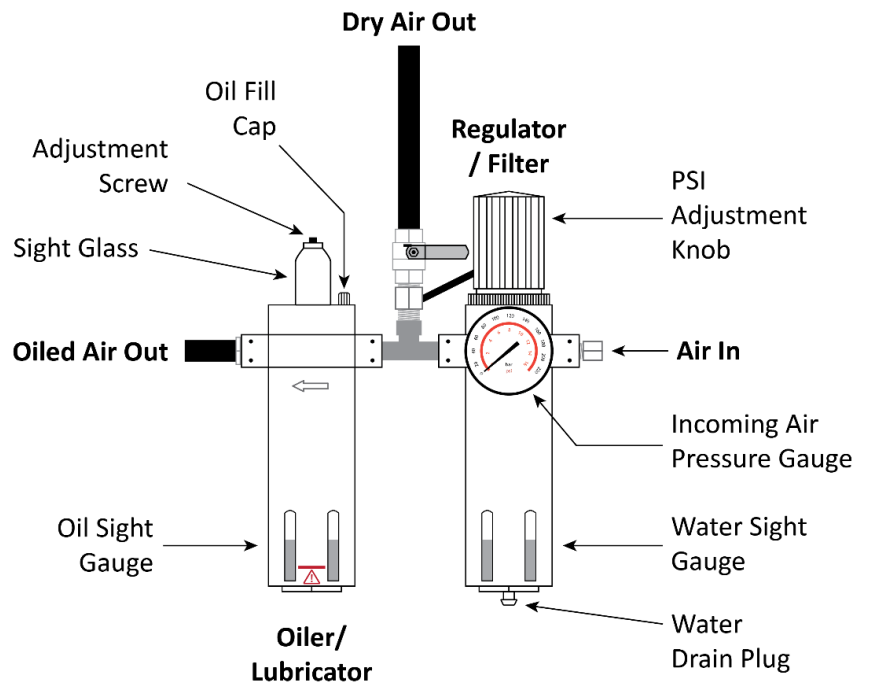

Drawing not to scale. Not all components shown.

The following drawing shows a quick-connect air fitting (shown on the right, below) that connects to the Air In connector (shown on the left, below). The fitting is **not** supplied with the Tire Changer.

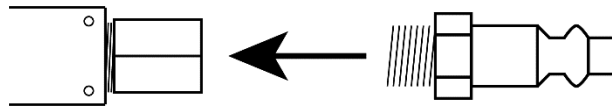

The **Regulator / Filter** removes contaminants from the incoming air. It also includes a gauge that shows the operating air pressure of the incoming air. If you see water in the Water Sight Gauge, you can drain it using the Water Drain Plug. Refer to **Maintenance** for more information.

The **Oiler / Lubricator** puts pneumatic oil, for lubrication, into the incoming air. This lubricated air is routed to pneumatic components of the Tire Changer.

Attach the Toolbox to the Tower

1. Remove any protective plastic from the Tower and the Toolbox.
2. Remove the four M6 x 16 SCHS, Washers and lock washers from the Toolbox bracket on the Main Tower above the Air Connections.
3. Install the Toolbox using the M16 SCHS , flat washers and lock washers just removed.

To Install the Inflation Gauge:

1. Locate the Inflation Gauge bracket on the left side of the Tower above the Turbo Blast. The side opposite the compressed air input.
2. Remove and retain the two M6 x 10mm SCHS, lock washers and washers from the bracket.
3. Retrieve the Inflation Gauge from its bag or protective wrap and mount it on the side of the Tower. Orient the gauge so the air lines are exiting at the bottom. Secure using the screws, lock washers and flat washers just removed.
4. Route the two air lines through the guides welded to the Tower and into the push-to-connect pneumatic fitting on the air line coming out of the back of the Tire Changer. Refer to the figure to the right. Connect like color tubes to like color tubes

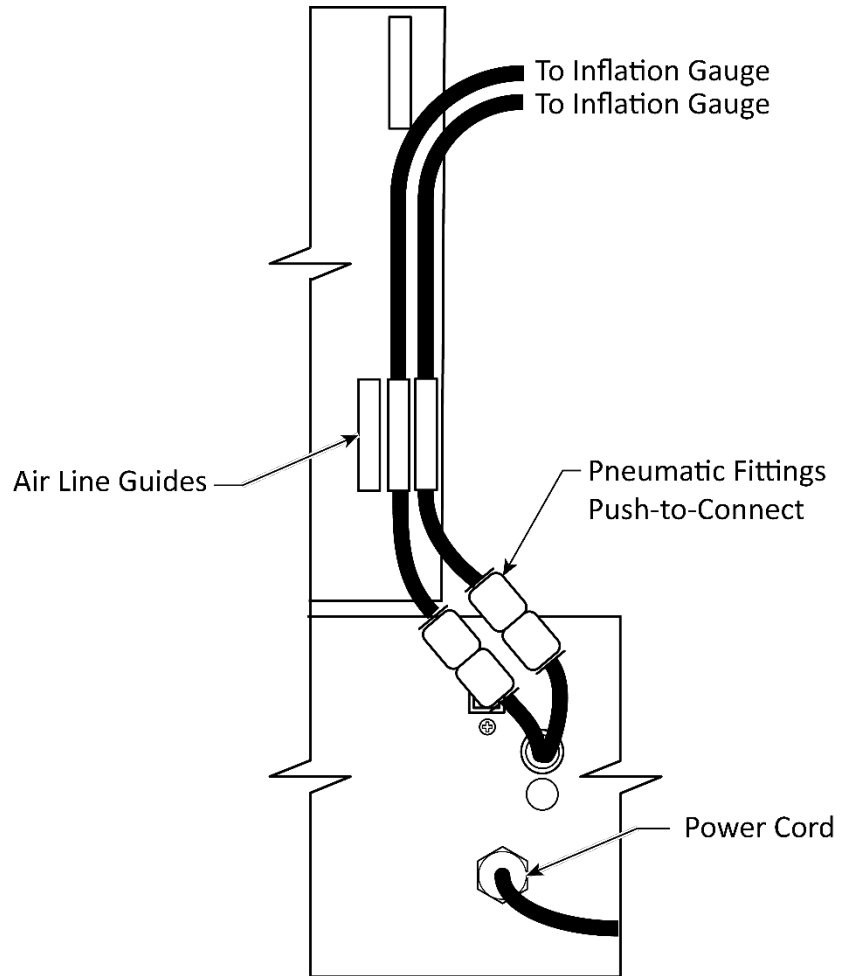

5. Install the Swing Adjustment Screw and Knob (208) into the Main Tower Swing Arm Bracket.

Moving the Tire Changer:

1. Remove any final bolts holding the Tire Changer to its pallet.
2. Move a forklift into position with its forks over the Tire Changer table extending back toward the Main Tower.
3. Using Lifting straps rated to support the Changer's load, place one lifting strap around the front of the Tire Changer roughly on the centerline of the Turntable and a second strap at the rear of the Tire Changer as close to the Main Tower as possible. Lift the Changer a few inches off of the pallet and verify that the Changer is stable and balanced.
4. Move the pallet out from under the Tire Changer.
5. Use the Forklift to carefully position the Tire Changer at the desired work location.
6. Carefully remove any additional packing and protective foam/plastic.
7. Remove excess shipping grease with clean rags.

Anchoring the Tire Changer

The Tire Changer has openings in the base for anchoring it into place; anchoring is optional.

Note: You are not required to anchor your Tire Changer. BendPak Ranger recommends doing so, as the Tire Changer uses force at various times during the changing of a Tire. Anchoring it ensures it will not move during operation.

The three .5 in / 12.7 mm holes for anchoring are located at:

- Front right
- Front left
- Rear right (under the Regulator/Filter)

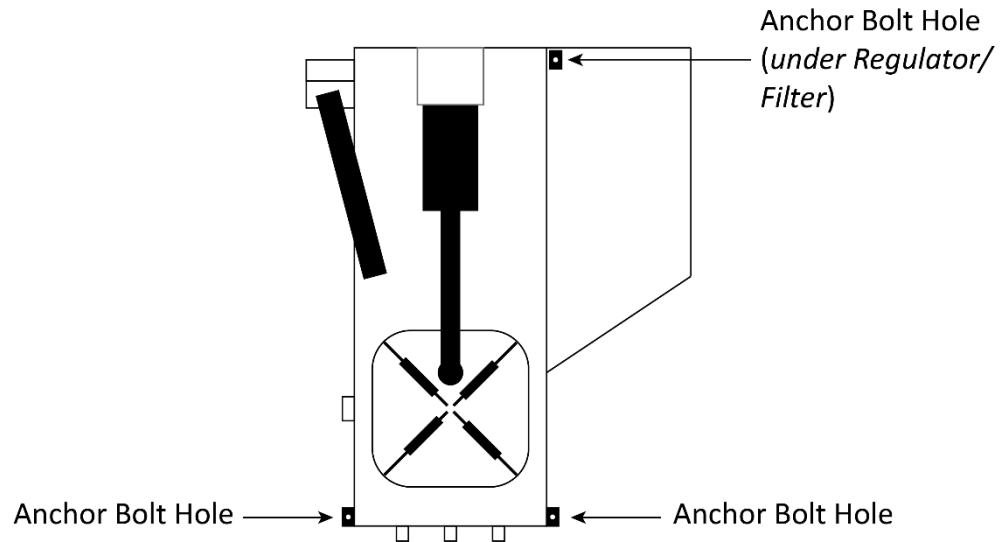

Top view. Not to scale.

The Anchor Bolts (sometimes called Wedge Anchors) mentioned in the following procedure are **not** supplied with the Tire Changer. You could, for example, use 3/8 in. by 3 in. Anchor Bolts to secure the Tire Changer, drilling the hole approximately 2.5 in / 63.5 mm deep into the Concrete.

To anchor the Tire Changer:

1. Verify the Tire Changer is in the desired location.
2. Using the holes as guides, drill the holes for the Anchor Bolts.

⚠ WARNING You **must** wear OSHA-approved (publication 3151) Personal Protective Equipment at all times when installing the Lift: leather gloves, steel-toed boots, eye protection, back belts, and hearing protection are **mandatory**.



Go in straight; do not let the drill wobble. Use a carbide-tied drill bit (conforming to ANSI B212.15).

Use a drill bit that is the same diameter as the Anchor Bolt. So, if you are using a 3/8 in diameter Anchor Bolt, for example, use a 3/8 in diameter drill bit.

3. Vacuum each hole clean.

BendPak recommends using a wire brush and a vacuum to get the hole very clean.

Do **not** ream the hole. Do **not** make the hole any wider than the drill bit made it.

⚠ WARNING You **must** wear safety glasses when clearing debris from the anchor holes.

4. Make sure the Washer and Nut are in place, then insert the Anchor Bolt into the hole.

The Expansion Sleeve of the Anchor Bolt may prevent the Anchor Bolt from passing through the hole in the base of the Tire Changer; this is normal. Use a hammer or mallet to carefully tap the Expansion Sleeve through the base and down into the hole.

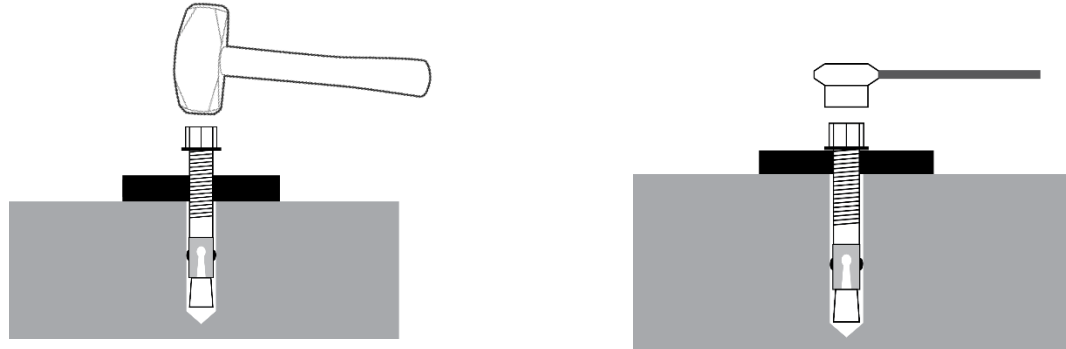

Even using a hammer or mallet, the Anchor Bolt should only go into the hole part of the way; this is normal. If the Anchor Bolt goes in with little or no resistance, the hole is too wide.

Once past the hole in the base, the Anchor Bolt eventually stops going down into the hole as the Expansion Sleeve contacts the sides of the hole; this is normal.

5. Hammer or mallet the Anchor Bolt the rest of the way down into the hole.

Stop when the Washer is snug against the base of the Tire Changer.

6. Use a torque wrench to tighten each Nut **clockwise** to the torque recommended by the manufacturer of the Anchor Bolt.

If no torque is specified, BendPak Ranger recommends ~55 lbf-ft / 74 N-m for a 3/8 in diameter Anchor Bolt.

Important: Do **not** use an *impact* wrench to torque the Anchor Bolts.

Wrenching the Nut forces the Wedge up, forcing out the Expansion Sleeve and pressing it tightly against the Concrete.

Connecting to Power

The **R980AT-L** Tire Changer must be connected to a 110 VAC power source on a **dedicated 20 Amp circuit**. The 110 VAC Unit's power cord is prewired with a plug.

The **R980AT** and **R980XR** Tire Changers must be connected to a 208-240 VAC power source, on a **dedicated 20 Amp circuit**.

A Power Cord with **no Plug** on the end is provided with the 220 VAC unit. You must have a licensed, certified Electrician either:

- Wire the **R980AT** or the **R980XR** Power Cord to an appropriate 208-240 VAC NEMA, 30 Amp Plug, which is then plugged in to an appropriate power outlet.
- or**
- Wire the Tire Changer directly into the facility's electrical system protected by an appropriate circuit breaker.

Important: The Tire Changer uses pneumatic and electrical energy; if your organization has Lockout/Tagout policies, implement them once the unit is connected to a power source.

Refer to **Wiring Information** for additional wiring information.

⚠ DANGER **All electrical work *must* be performed by a licensed, certified Electrician in accordance with all local, state and National Electrical Codes (NEC). If you do not use a licensed, certified Electrician, you void your warranty and put everyone who uses the Tire Changer in danger of injury or, in rare cases, death.**

Additional electrical information:

- Operation with no Ground can damage electronics and could create a shock hazard. **You must ground the unit.**
- Damage caused by improper electrical installation voids the warranty.
- The Tire Changer uses pneumatic and electrical energy; if your organization has Lockout/Tagout policies, make sure to implement them after connecting the unit to the power source.
- Make sure that adequate wire sizes are used, service is of adequate amperage rating, the supply line has the same electrical characteristics (voltage, cycle, and phase) as the motor, and that **no other equipment is operated on the same circuit.**
- Electrical codes in your area may require "hard-wiring" if the machine is anchored to the floor. Consult a licensed Electrician regarding the applicable codes for your location.

⚠ WARNING **Disconnect power and air pressure before performing any troubleshooting or maintenance.** Make sure the unit cannot be reenergized until you are done. This equipment has internal arcing or sparking parts that should not be exposed to flammable vapors. The unit must **not** be located in a recessed area or below floor level.

Prepare the Lube Bucket

The Tire Changer comes with a Lube Bucket (to hold your Lube) and a Lube Brush (to apply your Tire Lube).

BendPak Ranger does not include any Tire Lube with the Tire Changer, as there are many options available.

⚠ CAUTION Only use Tire Lube that is approved by the Tire manufacturer for the Tire you are changing. Using non-approved Lube could corrode the Wheel or cause Tire/Wheel slippage and vibration issues.

Be sure to use enough lubricant without using too much. The point of lubricant is to **temporarily** reduce the friction between the Tire Bead area and the Rim. What you are looking for is a lubricant that is slippery when wet but not slippery once dried. If you notice excessive amounts of lubricant on the Tire or Rim, remove the excess.

There is a location on the Tire Changer for the Lube Bucket: between the Bead Breaker and the Turntable.

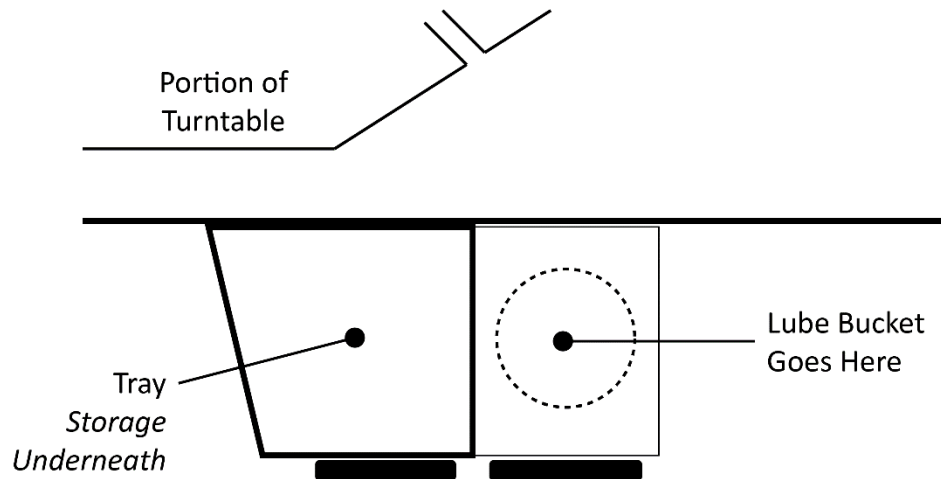

Top view. Not necessarily to scale. Not all components shown.

Grease the Assist Tower Post

The Assist Tower Post (R980AT only) needs to be greased as detailed below so the Assist Tower Arms can easily slide up and down.

The Tire Changer comes from the factory with the Assist Tower Post already greased. Re-grease the Post as required.

BendPak Ranger recommends a lithium-based grease that includes molybdenum and graphite. For example, Extreme Pressure Moly-Graph® Multi-Purpose Grease from CRC/Sat-Lube®.

⚠ CAUTION The lithium-based grease recommended for the Assist Tower Post is **not** a Tire lubricant. Do not use it to lube Tires. Once the Assist Tower Post is greased, try not to lean on it or touch it.

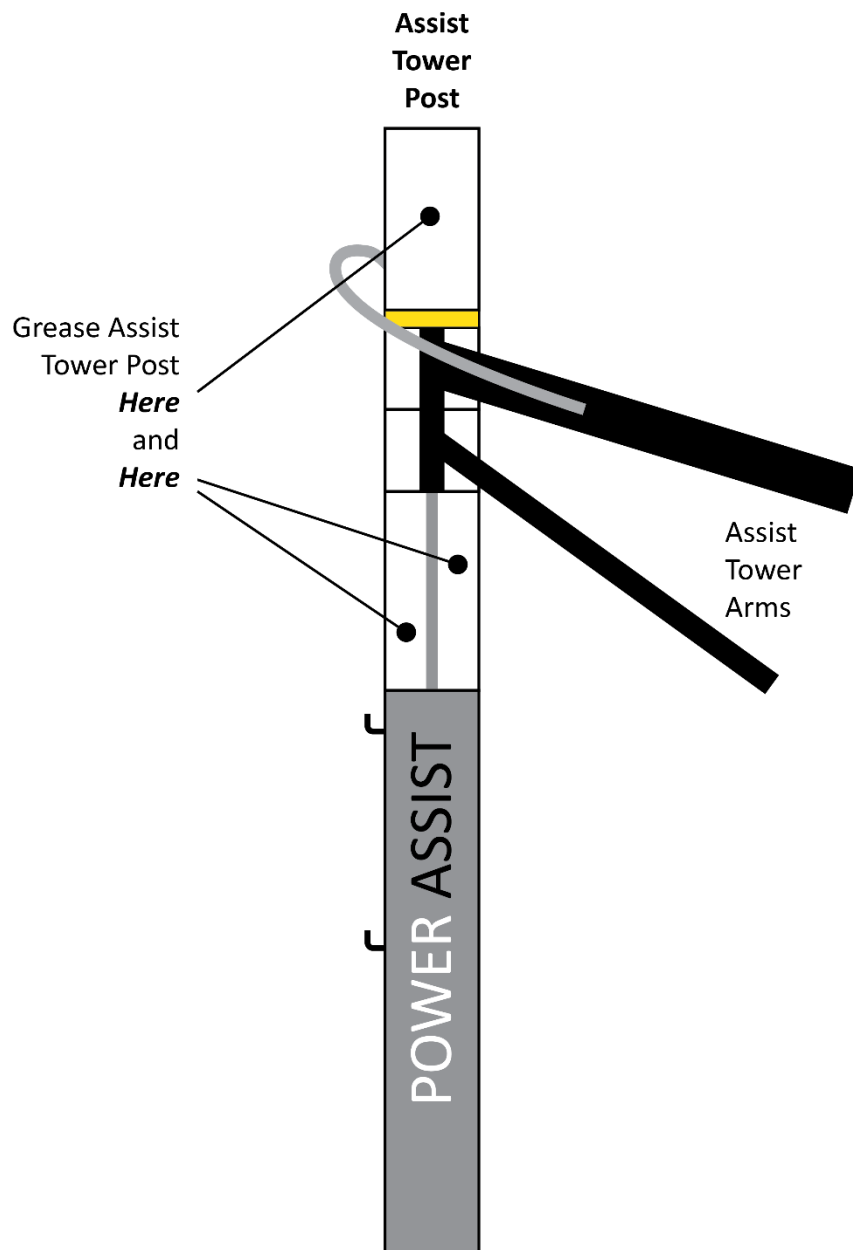

Side view. Not to scale. Not all components shown.

Test the Tire Changer

Make sure the following items have been done **before** putting the Tire Changer into normal operation:

- **Check for pneumatic (air) pressure.** The Tire Changer requires pneumatic energy to perform certain functions.
To see if the Tire Changer has air pressure, take the Air Chuck, and lightly step on and hold down the Inflation Foot Pedal. If air comes out, the Air Source is connected and working.
- **Test the power source.** Other Tire Changer functions require electric power. Step on and hold down the Turntable Foot Pedal to check for electric power. If the Turntable turns, you have power.
- **Make sure there is Tire lubricant available.** Your shop probably has a brand of Lube that it prefers. Make sure some is in the Lube Bucket on the Tire Changer. Always use Lube; it makes changing Tires easier and helps prevent damage to the Tire and the Wheel.
- **Test the Tool Arms.** Manually move each Tool Arm separately from side to side. Use the Assist Tower Controls to raise and lower the Tool Arms (they move up and down together). If the Tool Arms can do these things, they are working correctly.
- **Change some non-customer Tires.** To get used to the Tire Changer, BendPak Ranger recommends have all potential Operators change some *non-customer Tires* before putting the Tire Changer into normal operation.

Final Checklist before Operation

Do the following things **before** putting your Tire Changer into normal operation:

- Review the Installation Checklist to make sure all steps have been performed.
- Verify the Tire Changer is getting electric and pneumatic power.
- Check to see that all Anchor Bolts are in position and tightened if you installed them.
- Make sure the Tire Changer has been used to change some non-customer Tires.
- Leave the Manual with the owner/operator.

Operation

This section describes how to use your Tire Changer.

It describes the main components involved in demounting and mounting Tires, followed by the necessary procedures.

⚠ DANGER Being in close proximity to a Tire Changer is a serious endeavor with potentially life-threatening risks. Only trained, authorized, supervised personnel may be within 30 feet of the Tire Changer while it is in use. ***Do not assume you are going to be safe using the Tire Changer this time just because nothing happened last time.***

Usage Precautions

Keep the following in mind while you use your Tire Changer:

- Make sure all employees receive specific training in Tire demounting and mounting **before** they are allowed to use the Tire Changer, that their training is verified through a testing program, and that all training is documented. All others, including children and untrained personnel, must be kept at least 30 feet away from the Tire Changer while it is in use.
- Make sure new employees are trained and supervised in the performance of their duties.
- Never perform any service on an *inflated* Tire; **always** fully deflate the Tire by removing the Valve Core and letting the air escape before beginning work.
- Never mount or change **damaged** Tires or Wheels.
- When mounting Tires, identify the maximum allowed inflation pressure; it should be on the sidewall of the Tire. ***Do not exceed the maximum allowed inflation pressure of the Tire.***
- Make sure the Tire is restrained for inflation: either internally clamped, held down by the Centering/Inflation Tool, or in a Tire Inflation Cage (such as the **RIC-4716 4-Bar Tire Inflation Cage from BendPak Ranger**). Do not inflate a Tire if it is externally clamped; external clamping interferes with inflation.
- When using the Tire Changer, be careful of your hands; there are multiple pinch point dangers on the unit. ***Do not rest your hands on any part of the Tire Changer while using it.***

⚠ WARNING The Air Chuck has a self-gripping clip so that you can clip it on when inflating a Tire, which means you do not have to hold it in place during inflation. ***Do not hold the Air Chuck while you are inflating a Tire.*** This leaves you very close to the Tire, which could result in injury if there were a problem during the inflation. Instead, clip the Air Chuck into position, move away from the Tire, then press and hold down the Inflation Foot Pedal.

- You **must** wear OSHA-approved (publication 3151) personal protective equipment at all times when installing, using, maintaining, or repairing the Tire Changer. Leather gloves, steel-toed work boots, eye protection, back belts, and hearing protection **are mandatory**.
- When using the Tire Changer, the operator must wear **ANSI-approved** eye protection at all times: safety glasses, a face shield, or protective goggles.

⚠ WARNING Always wear ANSI-approved eye protection. An accident could cause significant injuries to your eyes.

-
- The Tire Changer may work differently than other Tire Changers you have used. BendPak Ranger recommends practicing with non-customer Tires to get familiar with how the product works *before* starting work on customer Tires.
 - Keep the work area clean and well lit. Dirty, cluttered, and dark work areas increase the chances of an accident happening.
 - Do not access the inside of the unit unless instructed to do so by BendPak Ranger Support.

 **WARNING** Be especially careful when inflating Tires. This is a dangerous time when using a Tire Changer. If the Tire and Wheel are mismatched or there is a defect in the Tire, it could explode, injuring or killing the Operator or bystanders. **Do not lean over the Tire when inflating a Tire.** Move away from the Tire during inflation.

- Do not use the Tire Changer in a wet environment or expose it to rain or excess moisture.
- If you need to use an extension cord to get power to the unit, use one with a current rating equal to or greater than that of the Tire Changer. Cords rated for less current than the Tire Changer could overheat. If used, arrange the extension cord so that it will not be tripped over or pulled out.
- Do not use anything flammable on the Beads or Rims as lubrication; instead, use non-flammable vegetable or soap-based rubber lubricant.
- Do not use the Tire Changer in the vicinity of open containers of flammable liquids.
- Clean the unit according to the instructions in **Maintenance**.
- Read the entire *Installation and Operation Manual* **before** using the Tire Changer.
- Make a visual inspection of the Tire Changer **before each use**. Do not operate the Tire Changer if you find any issues. Instead, take it out of service, then contact your dealer, visit www.bendpak.com/support/, or call BendPak Ranger at **(805) 933-9970**.

Turntable

The Turntable is where you the Wheel and Tire is clamped to be dismounting or mounting.

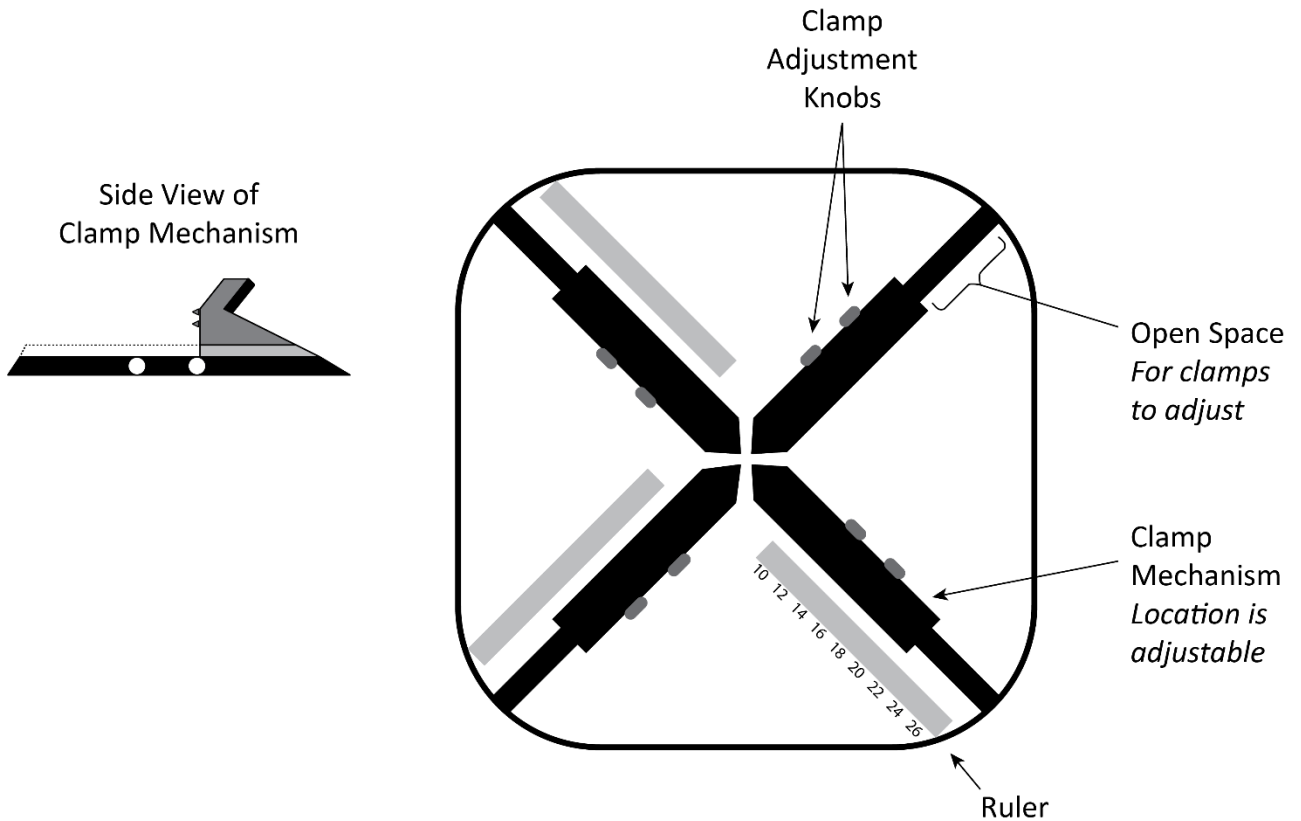

Top and side views. Not necessarily to scale. Not all components shown.

There are several important things to know about the Turntable:

- Flat, steel piece.** This is the actual Turntable. It holds the other components. It can rotate either clockwise or counterclockwise.
 - To rotate the Turntable clockwise:** Press **down** on the Turntable Foot Pedal.
 - To rotate the Turntable counterclockwise:** Press **up** on the Turntable Foot Pedal.
- Clamp Mechanism.** Each Clamp mechanism includes a Clamp and two Clamp Adjustment Knobs. The Clamp Mechanism moves in and out to clamp Wheels either externally or internally. “External” and “Internal” clamping refer to the location of the Clamp in relation to the Wheel.

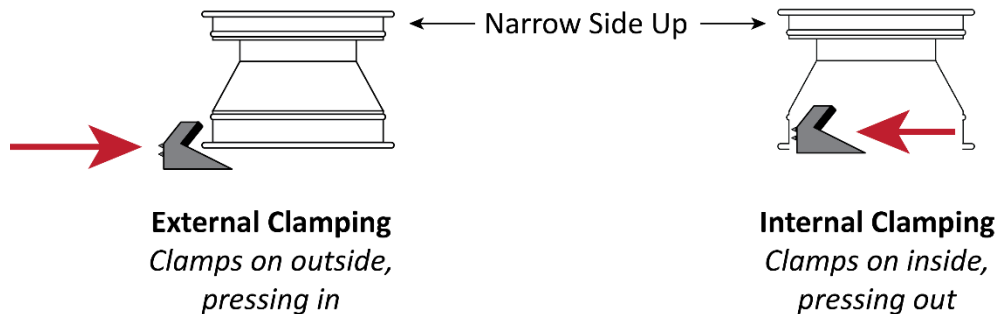

Side view. Some components exaggerated for clarity. Large arrows show direction Clamps are pressing. Only one of the four Clamps shown. Not necessarily to scale. Not all components shown.

As a general rule, you clamp steel Wheels internally (Clamps push out against Wheel) and custom and mag Wheels externally (Clamps push in against outside Rim edge). Check with your supervisor if you are unclear about which method to use for a particular set of Wheels.

To clamp externally. If necessary, use the Clamps Foot Pedal to move the Clamps all the way **out** (they may be all the way out already), position the Wheel between the Clamps, then press **down** on the Clamps Foot Pedal to move the Clamps **in** until the Wheel is being firmly held in place.

To clamp internally. If necessary, use the Clamps Foot Pedal to move the Clamps all the way **in** (they may be all the way in already), position the Wheel over the Clamps, then press down on the Clamps Foot Pedal to move the Clamps **out** until the Wheel is being firmly held in place.

Note: The Clamps Foot Pedal works as follows: If the Clamps are in the middle of the Turntable, pressing down and releasing the Clamps Foot Pedal moves them all the way out. If the Clamps are all the way out, pressing down and releasing the Clamps Foot Pedal moves them all the way back in.

- **Clamp Adjustment Knobs.** Move the Clamp between three different positions within the Clamp Mechanism to accommodate Wheels of different sizes.



Clamp
outer position

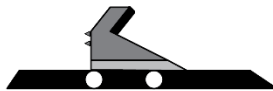

Clamp
center position

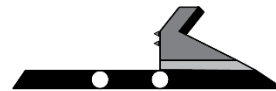

Clamp
inner position

To move a Clamp. Pull out and hold out the Clamp Adjustment Knob closest to the direction you want to move the Clamp, slide the Clamp in the desired direction, release the Clamp Adjustment Knob. If you want to move the Clamp again in the same direction, repeat the same procedure with the other Clamp Adjustment Knob. If the Clamp is in the center position, you can only move the Clamp one position in either direction.

Pedals

The Tire Changer has four Foot Pedals:

- **Inflation Foot Pedal.** Supplies air through the Air Pressure Gauge Cord.
- **Turntable Foot Pedal.** Rotates the Turntable. Press down to go clockwise, press up to go counterclockwise.
- **Clamps Foot Pedal.** Moves the Clamp Mechanisms in or out. Press down and release to move the Clamp Mechanisms out (if they are in), press down and release to move the Clamp Mechanisms in (if they are out). Pressing down and releasing the Clamps Foot Pedal moves the Clamps to the opposite location of where they were.
- **Bead Breaker Foot Pedal.** Press down to move the Bead Breaker Blade in; release the pedal to have the Bead Breaker Blade move back out to its starting position.

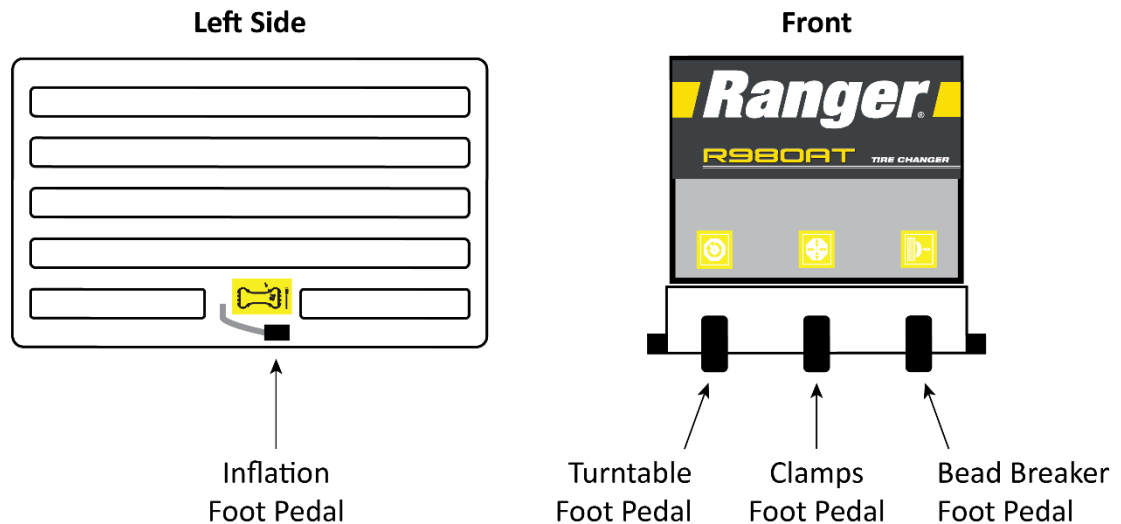

Top view. Not necessarily to scale. Not all components shown.

Air Pressure Gauge

Shows the air pressure in Tires to which the Air Chuck is attached.

The components of the Air Pressure Gauge are:

- **Gauge.** Displays air pressure in the Tire to which the Air Chuck is attached.
- **Pressure Relief Button.** Removes air if a Tire gets overinflated.
- **Cord.** Extends and retracts so you can get the Air Chuck to the Valve Stem.
- **Air Chuck.** Attaches to the threads on the Valve Stem. Includes a self-gripping clip so you do **not** have to hold the Air Chuck in place during inflation.

⚠ WARNING **Do not hold the Air Chuck while you are inflating a Tire.** This leaves you close to the Tire, which could result in injury if there is a problem during inflation.

- **Threads.** Store the Air Chuck here using the self-gripping clip.

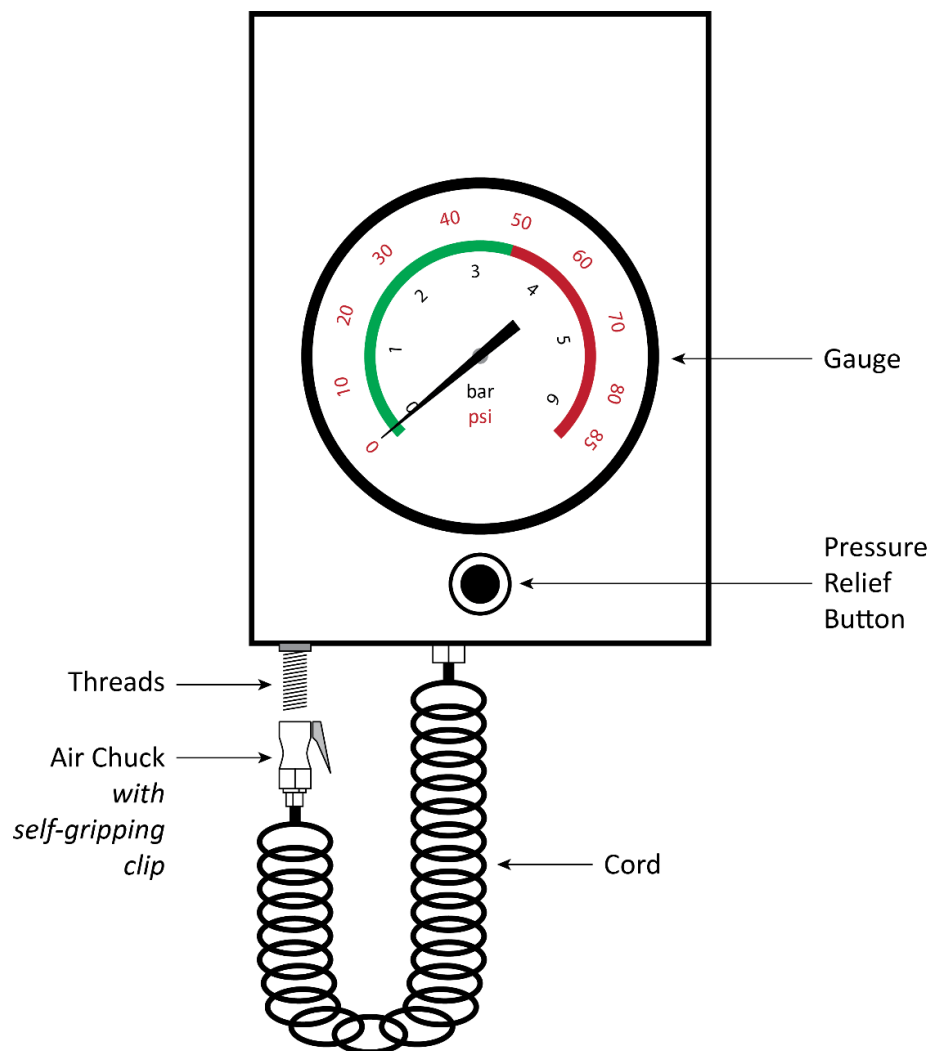

Front view. Not necessarily to scale. Not all components shown.

To see the pressure in a Tire: Attach the Air Chuck to the Tire; the Air Gauge shows the air pressure currently in the Tire. You do **not** need to press the Inflation Foot Pedal.

To see pressure during Tire inflation: Attach the Air Chuck, move away from the Tire, then press down the Inflation Foot Pedal. The Air Gauge shows the air pressure in the Tire as it inflates.

Swing Arm

The Swing Arm holds the main Tire Changer Tool, the Mount/Demount Head. It swings out of the way when you do not need it.

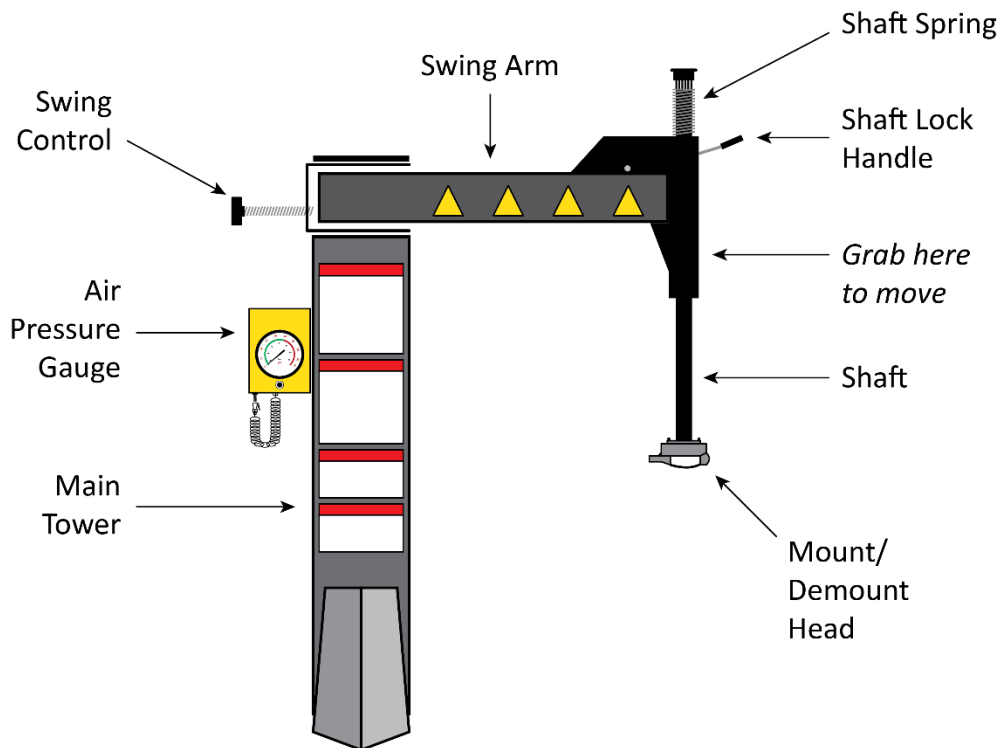

Front view. Swing Arm shown fully to the right. Not necessarily to scale. Not all components shown.

The main parts of the Swing Arm are:

- **Swing Arm.** When facing forward, puts the Mount/Demount Head directly over the middle of the Turntable. From that position, the Swing Arm can swing up to 90° to the right, which lets you get it out of the way when desired.
- **Swing Control.** Limits how far the Swing Arm can move. Makes sure the Mount/Demount Head cannot go past a point you control. Useful if you are going to be working on multiple Wheels that are exactly the same size; move the Mount/Demount Head to the desired location, then adjust the Swing Control so that the Swing Arm will return to this same position if moved out and then back.
- **Mount/Demount Head.** Attaches to the Bottom of the Shaft. The entire purpose of the Swing Arm is to let you get the Mount/Demount Head to where you need it.
- **Shaft.** Moves the Mount/Demount Head up and down. Grab the Mount/Demount Head to move the Shaft up and down. Do not grab the Shaft, it is greased.
- **Shaft Lock Handle.** Locks the Shaft in position when you get it to the right height. Locking the Shaft moves it a very small amount up.
- **Shaft Spring.** Pushes the Shaft and the Mount/Demount Head back up when you release the Shaft Lock Handle.
- **Moving the Swing Arm.** Grab the end of the Swing Arm below the Shaft Lock Handle and above the Shaft to move the Swing Arm (location shown in the drawing above). Do not grab the Shaft itself, as it is greased.

Mount/Demount Heads

The Mount/Demount Head is the main tool on the Tire Changer for demounting and mounting Tires. The Tire Changer comes with two Mount/Demount Heads:

- **Alloy Steel.** Lasts virtually forever. Silver in color. Includes plastic inserts on the inside to avoid damaging Rims and a roller for extra mounting functionality.

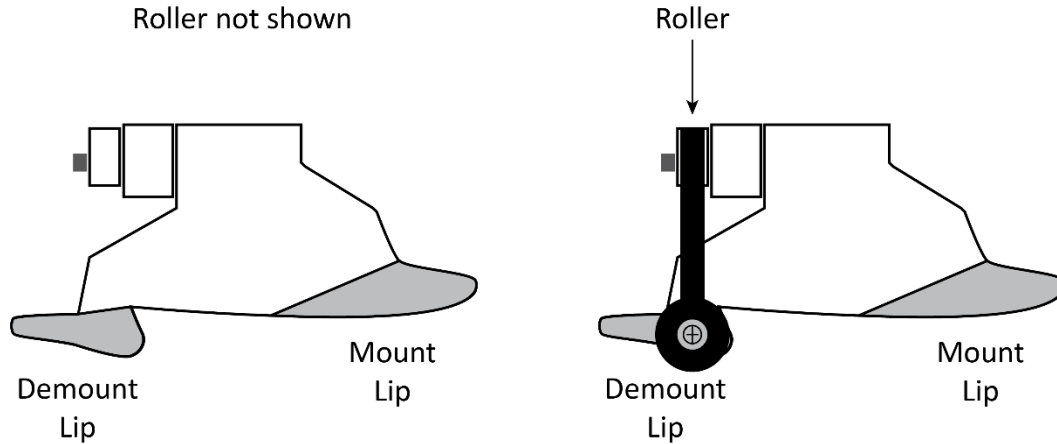

Side view. Set Screws on other side. Not necessarily to scale. Not all components shown.

- **Plastic Polymer.** Comes installed. Dark gray color. Non-marring surface will not scratch or otherwise damage paint or powder coating on wheels.

The following drawing shows the Plastic Polymer Mount/Demount Head with the Demount and Mount Lips identified. It also shows where the Tire Bead goes during demounting and mounting.

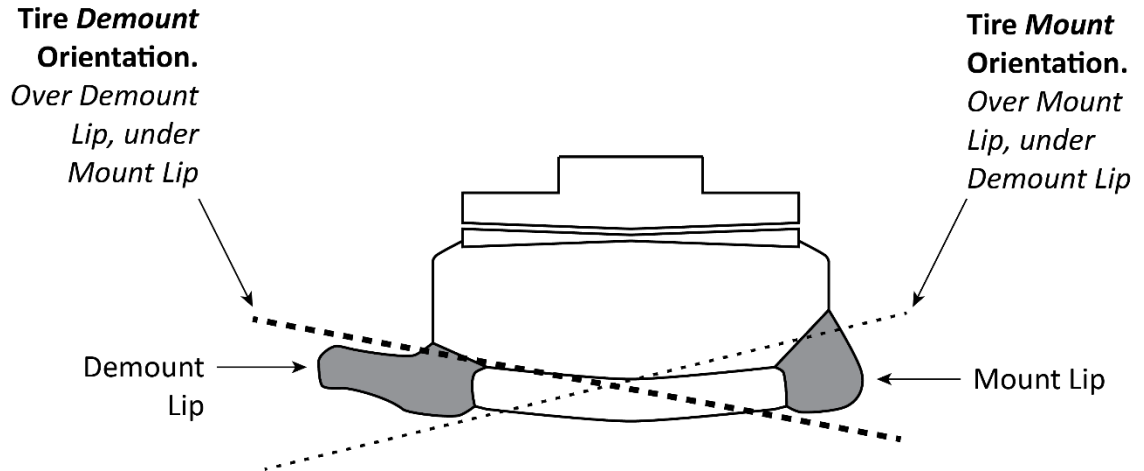

Side view. Set Screws on other side. Not necessarily to scale. Not all components shown.

The Demount Lip and Mount Lip work as follows:

- **During demounting.** The Tire Bead goes **over the Demount Lip** and *under the Mount Lip*.
- **During mounting.** The Tire Bead goes **over the Mount Lip** and *under the Demount Lip*.

You can easily switch between the two Mount/Demount Heads using the two Set Screws and a 6 mm hex wrench. Simply loosen the Set Screws, slide the Head down and off, replace it with the other one, and tighten the Set Screws.

Bead Breaker

Use the Bead Breaker to break the Beads (on both sides) of the Tires you are changing.

⚠ WARNING **Do not break the Beads of a Tire until you are certain the Tire is fully deflated.** Breaking the Bead of a Tire with air still in it could injure you or others nearby. The best way to be sure the Tire is fully deflated is to remove the Valve Core and wait for all of the air to come out.

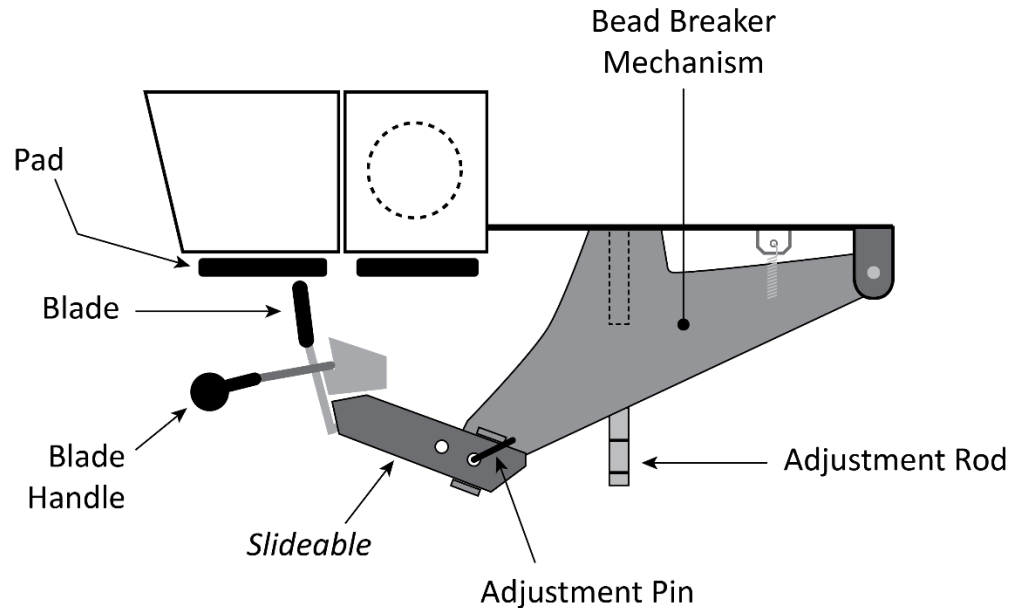

Top view. Not necessarily to scale. Not all components shown.

⚠ WARNING **There is a risk of crushing with the Bead Breaker.** Do not hold onto the Blade Handle when the Bead Breaker is moving. After positioning the Bead Breaker Blade, move away from the Bead Breaker, and make sure the area is completely clear, **before** pressing the Bead Breaker Foot Pedal.

The main parts of the Bead Breaker are:

- **Bead Breaker Mechanism.** Moves in and out under the control of the Bead Breaker Foot Pedal. Moves with great force; make sure you are completely clear of the Blade and the Bead Breaker Mechanism **before** pressing the Bead Breaker Foot Pedal.
- **Blade.** The part of the Bead Breaker that contacts the Tire and actually breaks the Bead.
- **Blade Handle.** Controls the Blade, moving it side to side and in and out.
- **Pads.** The side of the Tire whose Bead is **not** being broken goes against the Pads.
- **Adjustment Pin.** Allows you to accommodate Tires of different sizes by controlling the location of the Blade.

To use the Adjustment Pin: remove it from its current location, slide the metal piece holding the Blade to the other location, replace the Adjustment Pin.

- **Adjustment Rod.** Allows you to accommodate Tires of different sizes by controlling the location of the Bead Breaker Mechanism.

When the Adjustment Rod is in the **In** locking position, the Bead Breaker Mechanism can come out further, accommodating larger Tire sizes.

To use the Adjustment Rod. Grasp the end of the rod, then move the outside of the rod from its current locking position to the other locking position.

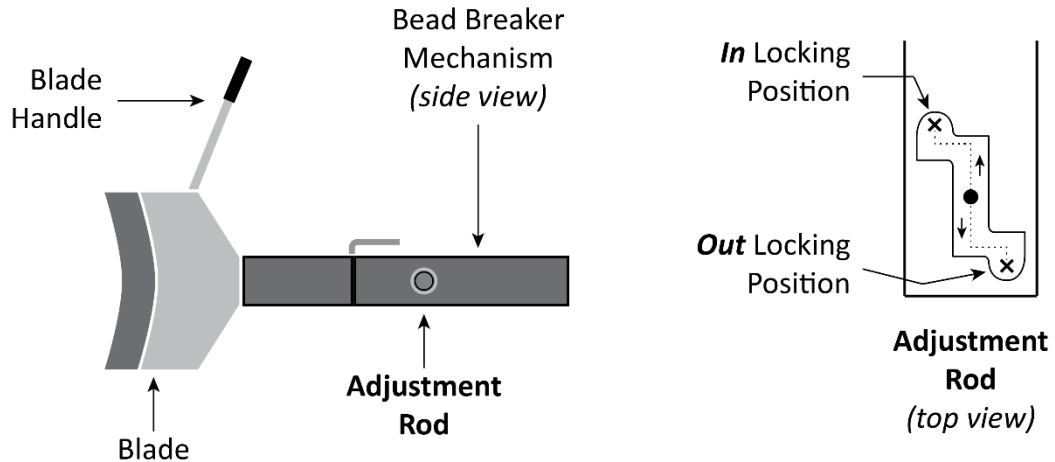

One side view, one top view. Not necessarily to scale. Not all components shown.

Bead Lifting Tool

Use the Bead Lifting Tool to pull the Tire's Bead up and over the Mount/Demount Tool to help demount the Tire.

You can also use the Bead Lifting Tool to push down the Tire's Bead — to the left of the Mount/Demount Head — during the mounting of a Tire.

The Bead Lifting Tool has an angled and a hooked end. You can use either end.



Assist Tower

The Assist Tower holds three Tools that make it easier to dismount, mount, and inflate Tires. These Tools are on two arms: the Upper Assist Arm and the Lower Assist Arm.

Important: The R980XR does *not* have an Assist Tower or the Tools on it. An Assist Tower is available for the R980XR as an option. Order from the [BendPak Ranger website](#), or call **(805) 933-9970**.

The two Assist Tower Arms move up and down as a *unit* but move side to side **independently**.

The components of the Assist Tower are:

- **Controls.** Moves the two Assist Tower Arms up and down together.
- **Upper Assist Arm.** Holds two Tools and the Controls.

The two Tools are:

- *Restraint Cone.* Used in two ways. First, when mounting a Tire, use the Restraint Cone to push the Tire down (helpful when clamping a Wheel externally). Second, when inflating a Tire, use to hold the Wheel in position. Long and Short versions available.
- *Assist Tool.* Used to hold down the top Bead during the mounting process.
- **Lower Assist Arm.** Holds a single Tool:
 - *Helper Disc.* Used to hold up the bottom Bead during the demounting process.

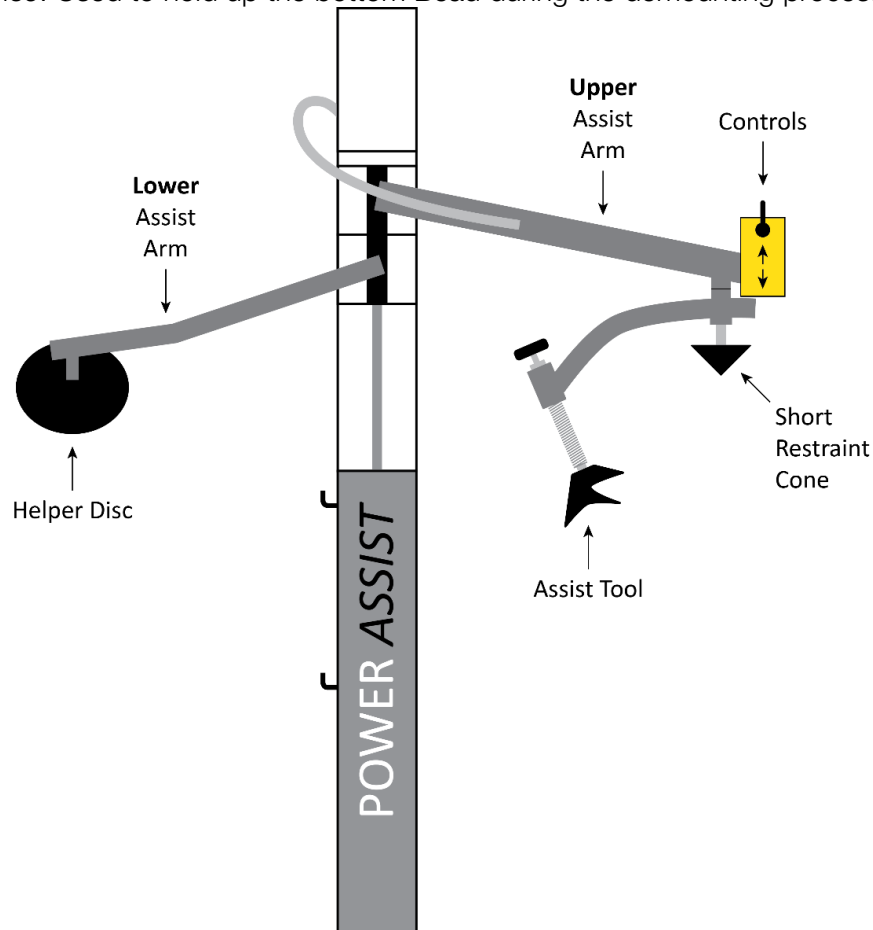

Front view. Not to scale. Not all components shown.

Before You Change a Tire

⚠ DANGER Do not use the Tire Changer unless you have been properly trained and have read the entire *Installation and Operation Manual*. Tire changing must only be done by trained, authorized, supervised personnel. **Failure to understand and follow proper procedures will result in injury or death.**

Before you change a Tire, you should:

- **Remove weights.** Check the Wheel to make sure that all clip-on and adhesive weights (from having the Tire balanced) have been removed.
- **Deflate the Tire.** This is required. **You must fully deflate Tires before demounting them.**

To make sure a Tire is *fully deflated*, remove the Valve Core from the Valve Stem. You should use a Valve Core Tool for this, but if you do not have one, you may be able to use needle-nosed pliers.

- **Have Tire lubricant ready.** Tire Lubricant makes the process of demounting and mounting Tires much easier. If you do not use Tire Lubricant, you significantly increase the chances of damaging the Wheel and the Tire. Tire Lubricant is not provided with the Tire Changer.
- **Check for damage.** Especially with expensive Wheels, make sure to check them for any damage *before* changing the Tire. Depending on the circumstances, if you find any damage you might want to discuss that damage with the owner of the Vehicle and/or photograph the damage. If you work in a shop, talk to your supervisor regarding shop policies in this area.

Additionally, damaged Wheels and Tires are dangerous to work with. If you are not sure whether a Wheel or Tire is too damaged to work with, talk to your supervisor.

- **Understand Performance Wheels.** Before servicing performance Wheels, review the Performance Wheels section of this manual.
- **Identify the Narrow Side/Drop Center of the Wheel.** The rule is: the Narrow Side/Drop Center side of the Wheel gets put onto the Tire Changer facing up. For most Wheels, this means the side of the Wheel facing the *outside* of the Vehicle goes on top, because that's where the Narrow Side/Drop Center side is on most (but not all) Wheels.

The following drawing shows two Wheels and identifies the Narrow Side, Drop Center, and Wide Side of each.

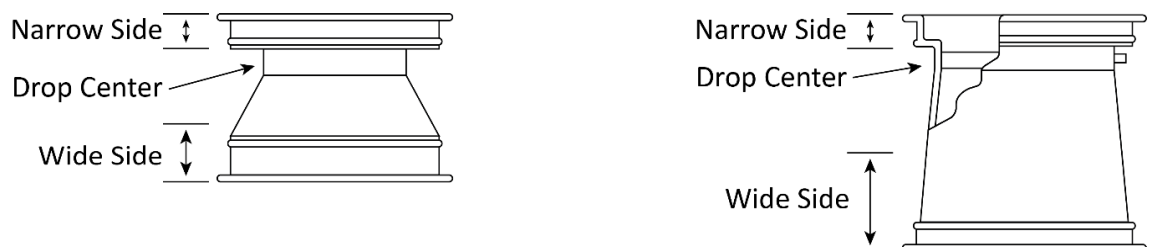

Some aftermarket and OEM performance Wheels are **reverse** drop-center Wheels, meaning the Narrow Side/Drop Center side of the Wheel is closer to the *inside* of the Vehicle. The rule still holds for these Vehicles: the Narrow Side/Drop Center side of the Wheel gets put onto the Tire Changer facing up.

- **Ask your Supervisor.** If you have **any** concerns about a Tire you have been asked to demount or mount, or about how to use the Tire Changer, consult with your supervisor **before** starting work.

Working with Custom and Special Wheels

This section covers working with Alloy Wheels with no drop center, European performance Wheels, and Wheels with tire pressure monitoring systems.

Alloy Wheels

Some manufacturers offer Wheels with little or no drop center. These types of Wheels are almost never Department of Transportation approved.

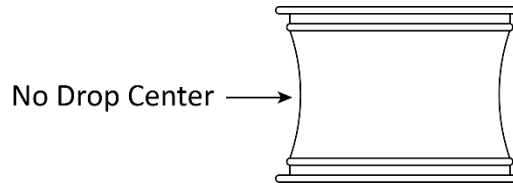

⚠ DANGER

The Tire, Wheel, or both can be damaged, and the Tire could explode under pressure, resulting in serious injury or death. ***BendPak Ranger recommends you not try to demount or mount this type of Wheel.*** If you do attempt to demount or mount this type of Wheel, ***proceed with extreme caution.***

European Performance Wheels

Some European performance Wheels have very large humps except near the Valve Hole.

On these Wheels, the Beads should be loosened at the Valve Hole on both the upper and lower sides first.

Wheels with Tire Pressure Monitoring Systems (TPMS)

Some Wheels have a pressure sensor located behind the Valve Stem. On these Wheels, the Beads should be loosened opposite the Valve Stem on both upper and lower sides first, before breaking the Beads on the rest of the Tire.

Performance Wheels on some Vehicles (including Corvette, BMW, and Lamborghini Diablo) have a pressure sensor strapped to the rim opposite the Valve Hole. On these Wheels, the Beads should be loosened at the Valve Hole on both the upper and lower sides first, before breaking the Beads on the rest of the Tire.

Be mindful of the TPMS sensor when breaking a Tire's Bead, demounting a Tire, and mounting a new Tire. If your shop does not have specific recommendations for handling these situations, BendPak Ranger recommends:

- **When breaking a Tire's Bead.** Keep the TPMS sensor away from where the Bead is being broken. Put the sensor at 12 o'clock high (relative to the ground) when breaking the Bead.
- **When demounting a Tire.** Put the TPMS sensor just to the right of the Mount/Demount Head.
- **When mounting a Tire.** Put the TPMS sensor just to the left of the Mount/Demount Head.

These are general guidelines; be sure to use common sense and take into consideration the specifics of each situation.

When finished mounting a Tire with a TPMS sensor, check that it is working. It is against the law to knowingly not re-install a working TPMS if the Vehicle arrived at the facility with a functioning TPMS. In other words, if a Vehicle came in with a functioning TPMS, it needs to leave with a functioning TPMS.

The Steps in Changing a Tire

Before you start working on a Tire, review the requirements in [Before You Change a Tire](#).

Changing a Tire consists of multiple steps:

1. **Deflate the Tire.** There is a lot of energy stored in a Tire when it is inflated. You **must fully** deflate the Tire before you can demount it. If you do not, that energy will be released when you try to demount it, which could result in the Tire exploding, causing injury and even death to the Operator or bystanders. **Never work on a Tire unless you have personally confirmed that it is fully deflated.** The best way to do this is to make sure the Valve Core has been removed from the Valve Stem.
2. **Break the Bead.** Tires stay in position because the Tire Bead is seated between the Bead Retainer and the Rim Lip of the Wheel (called the Bead Seat). To demount a Tire, you must get the Bead out of the Bead Seat all the way around both sides of the Tire. This is called Breaking the Bead. Use care when Breaking the Bead of Wheels with a TPMS.
3. **Secure the Wheel on the Turntable.** It is important for the Wheel to stay in place on the Turntable. The Tire Changer supports both Internal and External Clamping.

 **WARNING** Do not stand on the Tire Changer Frame, or Turntable while demounting or mounting a Tire.

4. **Demount the Tire.** Once the Bead is broken, you still have to slide both Beads over the Rim Lip of the Wheel to get it fully off. Once the Tire is demounted from the Wheel, you can move it out of the way and then mount the new Tire.
5. **Mount the new Tire.** Mounting a Tire is basically the opposite of demounting. You first need to get the Beads under the Rim (the opposite of demounting the Tire), get the Beads into position **in** the Bead Seats (the opposite of Breaking the Bead), and then inflate the Tire (the opposite of deflating the Tire).
6. **Inflate the Tire.** Three separate stages: Bead Seal, Bead Seat, Inflate. **Bead Sealing** is putting in a small amount of air pressure to push the Tire up against the Rim so that no more air leaks out. **Bead Seating** is putting in more air pressure to “pop” the Beads into position in the Bead Seats. **Inflation** is adding air pressure to the Tire manufacturer’s recommended pressure after the Beads have been seated.
7. **Remove the Wheel from the Turntable.** Disengage the Clamps, then move the Wheel and Tire off the Turntable and back onto the ground.

About Valve Stems

The following drawing shows a Valve Stem and its components.

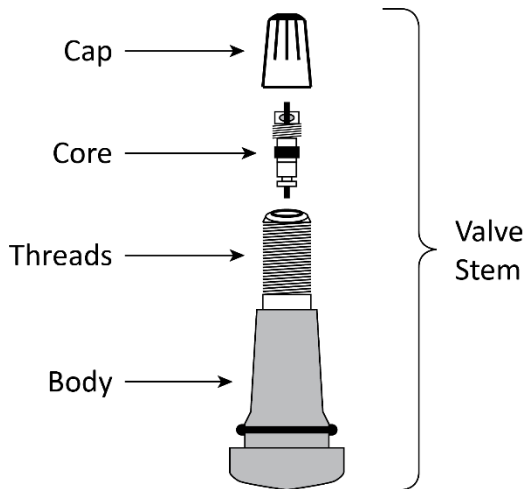

This manual talks about Valve Cores and Valve Stems at multiple points:

- **When demounting a Tire.** Taking out the Valve Core lets the air out of the Tire, which **must** be done before you can demount a Tire.
It is dangerous to do any service on a Tire if there is air still in it.
There is a tool called a Valve Core Tool that makes it easy to remove a Valve Core.
- **When replacing the entire Valve Stem.** Valve Stems are normally replaced when you mount a **new** Tire on a Wheel.
When mounting a new Tire, BendPak Ranger recommends installing a new Valve Stem, but it is not required. The process for replacing a Valve Stem is to cut out or pull out the old Valve Stem, then install the new Valve Stem. This should be done after the old Tire has been demounted but before the new Tire is mounted.
There is a tool called a Valve Stem Installer/Remover Tool (sometimes Valve Stem Puller/Remover Tool) that can be used to both remove an old Valve Stem and install a new Valve Stem.
This tool is **not** the same tool as the Valve Core Tool.
- **When inflating a Tire.** Before starting the first stage of inflating a Tire (sealing the Beads), remove the Valve Core. **Make sure to keep it.** Removing the Valve Core allows air to move more easily into the Tire.
Once the *second* stage of inflating a Tire (seating the Beads) is complete, put the Valve Core back in.
Sealing and seating the Beads do not put too much air pressure into the Tires. Inflating the Tire, the third stage, does. The Valve Core must be installed for the inflation stage, as that will keep the air from coming back out of the Tire.

Deflate the Tire

You must **fully deflate** a Tire before you can demount it.

⚠ DANGER Never attempt to demount or mount an **inflated** Tire. They must be deflated. Attempting to demount or mount an inflated Tire could cause it to explode, which could result in injury or even death.

To deflate a Tire:

1. If the Valve Stem has a Cap on it, remove it.
2. Pull the Valve Core out of the Valve Body.

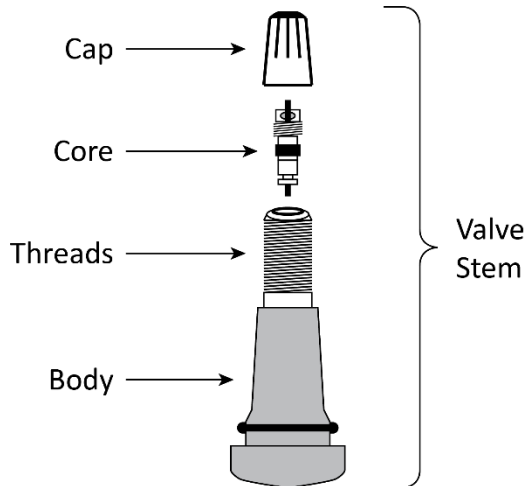

Use a Valve Core Tool to remove the Valve Core. If a tool is not available, you may be able to use needle-nosed pliers.

If you are going to use the same Valve Stem with the new Tire you are going to mount, keep the Valve Core you just took out.

BendPak Ranger recommends installing a new Valve Stem when you mount a new Tire.

3. Make sure all of the air comes out of the Tire.

⚠ WARNING Do not proceed with any other Tire changing activity until you are certain the Tire is **fully** deflated. Do not demount a Tire until you yourself have made sure the Tire is fully deflated. In other words, do not take someone's word for it. If you are demounting a Tire, **you** must make sure it is **fully** deflated.

Break the Beads

The Beads must be broken – on both sides of a Tire – before the Tire can be demounted.

⚠ WARNING Do not Break the Bead of a Tire until **you** have made sure the Tire is fully deflated. A Tire with air still in it could explode, injuring the Operator or bystanders.

The Bead is broken when the Tire Beads come out from between the Rim Lip and the Bead Retainer (the Bead Seat) all the way around the Tire, on both sides of the Tire.

To break a Tire's Beads:

1. Make sure you are wearing OSHA-approved (publication 3151) personal protective equipment: leather gloves, steel-toed work boots, back belts, hearing protection, and ANSI-approved eye protection (safety glasses, face shield, or goggles).
2. Check the Tire again to make sure it is **fully** deflated.
3. Check both sides of the Tire to make sure all Wheel weights (from balancing) have been removed. If they have not, remove them.

⚠ CAUTION Breaking the Beads of a Tire with Wheel weights could damage the Tire Changer and/or the Wheel.

4. Identify the Narrow side of the Tire whose Beads you are breaking; break this side first.
5. Move the Tire into position between the Pads and the Bead Breaker Blade, with the Narrow side of the Tire on the Blade side.
6. Depending on the size of the Tire whose Bead you are breaking, you may need to adjust the position of the Blade or use the Adjustment Rod to adjust the Bead Breaker Mechanism.

Refer to **Bead Breaker** for more information.

7. If you are Breaking the Beads of a Tire with a TPMS, put the sensor at 12 o'clock high or 6 o'clock low (relative to the ground), to reduce the chances of damaging it.



8. Move the Blade so that it is on the side of the Tire, very close to, **but not touching**, the Rim.

⚠ CAUTION Make sure the Blade is **not** touching the Rim. The Bead Breaker Mechanism uses a great deal of force; the Rim could be damaged if the Blade pushes on it instead of the side of the Tire.

-
9. Step on and hold down the Bead Breaker Foot Pedal.

The Blade pushes in, moving the Bead out of the Bead Seat and in towards the Drop Center of the Tire.

When the Bead breaks, it frequently (but not always) makes an audible popping sound.

10. If the Blade does not fully move the Bead out of the Bead Seat, adjust the Blade a little bit one way or the other and then step on and hold down the Bead Breaker Foot Pedal again.

11. When the Bead is broken, rotate the Tire 180° and break the Bead at that location.

Every Tire is different. With some Tires, the entire Bead on one side could be broken with the first use of the Bead Breaker Blade. Other Tires could take multiple attempts until the Bead is broken all the way around the Tire.

12. When the Bead is completely broken all the way around on one side of the Tire, move the Tire out, turn it around, and then break the Bead on the second side of the Tire.

Again, avoid breaking the Bead at the TPMS; you could damage the sensor.

Important: It may take you two or three times to break the Bead at any one spot. Nevertheless, keep going until you break the Bead all the way around the Tire and on both sides of the Tire. Do not proceed to demounting the Tire until the Bead is broken all the way around and on both sides of the Tire.

Secure the Wheel on the Turntable

Before you can demount a Tire, you must secure the Wheel on the Turntable. The Tire Changer supports two ways of securing the Wheel to the Turntable:

- **External clamping.** The Clamps are on the outside, pressing inwards.
- **Internal clamping.** The Clamps are on the inside, pressing outwards.

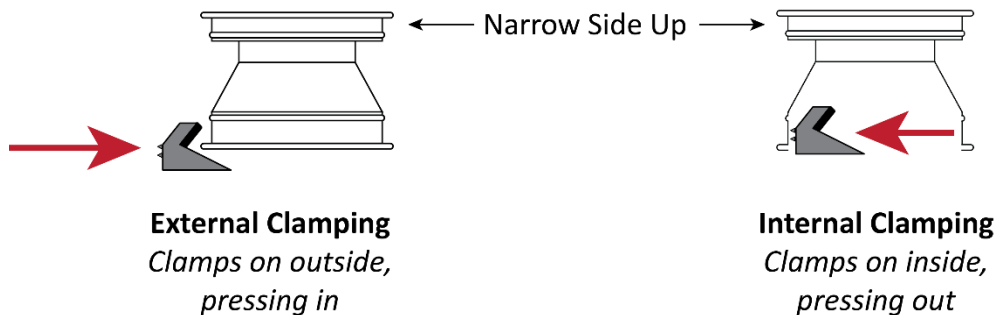

As a general rule, steel Wheels clamp internally (Clamps push out against Wheel) and custom and mag Wheels clamp externally (Clamps push in against outside Rim edge). Check with your supervisor if you are unclear about which method to use.

To secure a Wheel on the Turntable:

1. Make sure you are wearing OSHA-approved (publication 3151) personal protective equipment: leather gloves, steel-toed work boots, back belts, hearing protection, and ANSI-approved eye protection (safety glasses, face shield, or goggles).
2. Identify the Narrow side of the Tire; this side goes up.
3. Determine which clamping method you are going to use.
 - If you are clamping externally, press **up** on the Clamps Foot Pedal to move the Clamps all the way **out**.
 - If you are clamping internally, press **down** on the Clamps Foot Pedal to move the Clamps all the way **in**.
4. Put the Wheel onto the Turntable, either between the Clamps that are all the way out for external clamping or over the Clamps that are all the way in for internal clamping.
5. Secure the Wheel:
 - If you are clamping externally, press **down** on the Clamps Foot Pedal to move the Clamps **in** until the Wheel is being firmly held in place.
 - If you are clamping internally, press **up** on the Clamps Foot Pedal to move the Clamps **out** until the Wheel is being firmly held in place.



Tip

Clamping externally can be difficult on some Tires. If you are having problems getting the Clamps to clamp externally, either press down on the Wheel from above or, if you are using the R980AT, use the Restraint Cone to push the Wheel down from above. Pushing down from above moves the Rim away from the Tire, making it easier for the Clamps to grab the Rim.

Demount the Tire

Demounting a Tire is the process of taking a Tire off a Wheel. Specifically, you need to pull the top Bead over the **top** of the Rim, then pull the bottom Bead also over the **top** of the Rim.

⚠ CAUTION You **must** use Tire lubricant; this makes the Tire demount more easily and helps to prevent damage to the Wheel and/or the Tire.

During demounting, the Bead goes over the Demount Lip of the Mount/Demount Head but stays under the Mount Lip. See **Mount/Demount Heads** for additional information.

⚠ WARNING The following procedure **requires** that the Tire's Beads are broken on **both** sides. **Do not** try to demount a Tire whose Beads are not broken on both sides; you could damage the Wheel, the Tire, or even injure yourself or bystanders.

To demount a Tire:

1. Make sure you are wearing OSHA-approved (publication 3151) personal protective equipment: leather gloves, steel-toed work boots, back belts, hearing protection, and ANSI-approved eye protection (safety glasses, face shield, or goggles).
2. Verify that the Tire's Beads are completely broken on both sides of the Tire.
3. Apply Tire lubricant to both the top and bottom Tire Beads and the top and bottom Rim.
This helps slide the Beads over the Rims more easily.
4. Move the Mount/Demount Head into position, very close to the Rim **but not touching it**, and lock it in position using the Shaft Lock Handle.



Tip

If you are working on multiple Wheels of exactly the same size, you can “lock” the Mount/Demount Head to this location using the Swing Control, located next to the Swing Arm at the top of the Tire Changer. Refer to **Swing Arm** for more information.

At this point, the top Bead is under both the Mount Lip and the Demount Lip; it needs to be brought up over the top of the Demount Lip.

5. Push the top Bead 180° opposite the Mount/Demount Head into the Drop Center of the Wheel.
This gives you some extra room to help pull the top Bead over the Demount Lip.

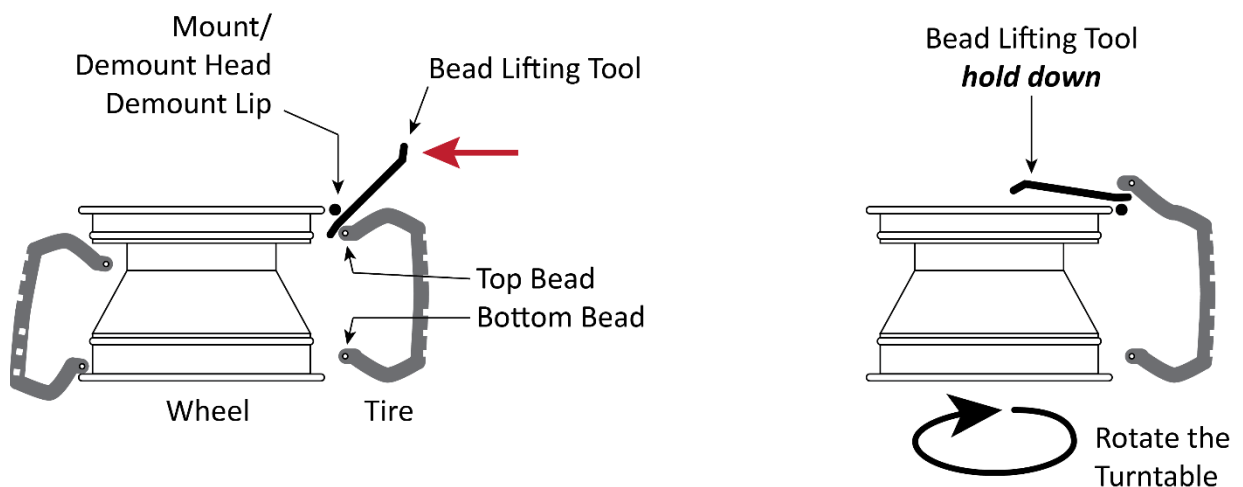

Tires not shown for clarity. Side view. Not necessarily to scale.

-
6. Take the Bead Lifting Tool, position one end on the outside of the Demount Lip of the Mount/Demount Head, then slide it down between the Demount Lip and the top Tire Bead until it is just past (and a little under) the Bead.
 7. Carefully push the Bead Lifting Tool in towards the middle of the Wheel in an arc.

This pulls the top Bead over the Demount Lip of the Mount/Demount Head, which is what you want.

⚠ CAUTION **Hold on to the Bead Lifting Tool.** Depending on the Tire, it may take a good deal of force to move the Bead up and over the Demount Lip. If you were to release the Bead Lifting Tool at this point, it could easily injure the Operator or damage the Wheel, Tire, or the Tire Changer.

Check to make sure the Bead Lifting Tool is lifting the Tire Bead up and over the Demount Lip of the Mount/Demount Head. If the Tire Bead is **not** coming up and over the Demount Lip, pull the Bead Lifting Tool out and start again.

8. When the Bead Lifting Tool has moved all the way over to the middle of the Wheel, check the top Bead to make sure it is above the Demount Lip.

The top Bead **must** be above the top of the Demount Lip to proceed.

Continue holding the Bead Lifting Tool.

9. Press down the Turntable Foot Pedal so that the Turntable begins turning clockwise.

Note: If you have difficulty getting the Turntable to move clockwise, release the Turntable Foot Pedal, keep hold of the Bead Lifting Tool, and then press up on the Turntable Foot Pedal for few seconds to move the Turntable counterclockwise, then press down again to move clockwise. Repeat as necessary to clear up the difficulty.

Watch the top Bead to make sure it is being pushed over the Rim, all the way around the Tire, as the Turntable moves.

10. Keep turning the Turntable until the entire top Bead pops over the top of the Rim.
11. When the top Tire Bead pops over the Rim, release the Turntable Foot Pedal, and remove the Bead Lifting Tool.

The top Bead is demounted.

The next step is to demount the bottom Bead over the top Rim.

12. Make sure there is still lubricant on the bottom Bead and the top Rim.

If there is not, put some more on.

13. Push the bottom Bead up as much as possible all the way around the Wheel, then push the side of the Tire opposite the Mount/Demount Head into the Drop Center of the Wheel.

If you are using the R980AT, you can position the Helper Disc to hold up the side of the Tire opposite the Mount/Demount Head. If you are using the R980XR, you can manually lift the opposite side of the Tire.

14. Take the Bead Lifting Tool, put it on the outside of the Demount Lip, then slide it down past and under the bottom Bead.

Getting the Bead Lifting Tool into position may be trickier this time, as the rest of the Tire is in the way as you are trying to get access to the bottom Bead.

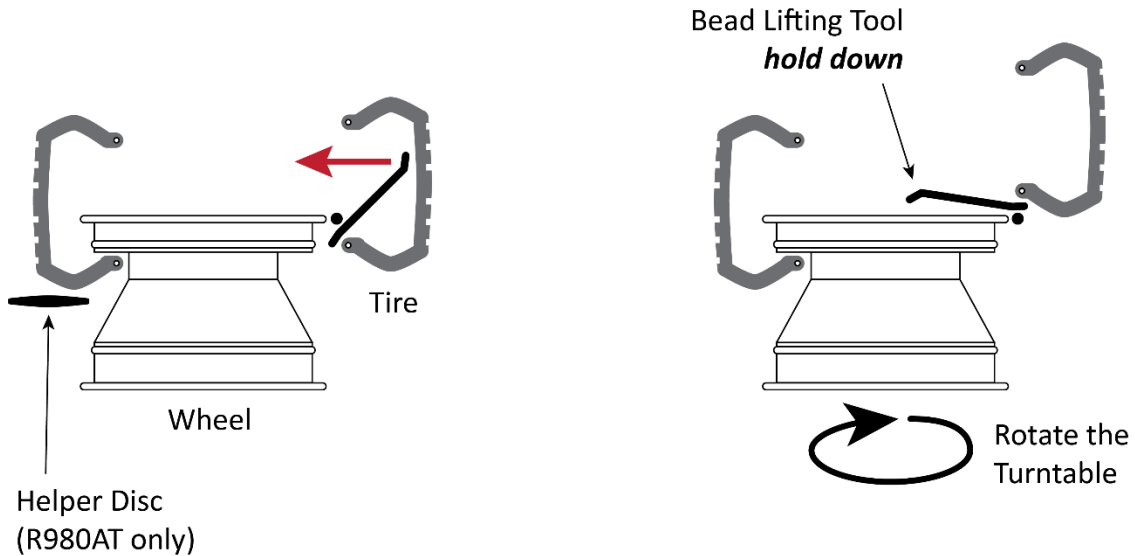

Tires not shown for clarity. Side view. Not necessarily to scale.

15. Push the Bead Lifting Tool towards the middle of the Wheel in an arc, pulling the bottom Bead over the Demount Lip of the Mount/Demount Head.

16. While continuing to hold the Bead Lifting Tool, press down on the Turntable Foot Pedal to move the Turntable clockwise.

Watch the bottom Bead to make sure it is being pushed over the top of the Rim as the Turntable moves.

17. Keep turning the Turntable until the entire bottom Bead pops over the top Rim.

The Tire is now dismounted and can be removed.

Wheel / Tire Mismatches

A Wheel / Tire mismatch is mounting a Tire where the Tire's Bead diameter does not exactly match the Diameter of the Wheel.

⚠ DANGER **A Wheel / Tire mismatch is extremely dangerous.** A mismatched Tire and Wheel may separate or explode, resulting in injury or even death.

The differences can be subtle, so you must take care to get an **exact match**.

For example, a 16-inch Tire goes on a 16-inch Wheel, not a 15.5 or a 16.5-inch Wheel. It may be possible to slide the 16-inch Tire over the Rim Lip of a 16.5-inch Wheel, but during inflation it will **not** seat properly.

⚠ WARNING **Do not** mount a Tire on a Wheel until you, **yourself**, have positively identified and correctly matched the Tire and Rim diameters. If you try to seat a Tire Bead on a mismatched Wheel and Tire by inflating it, the Tire Bead may break with explosive force, which could result in serious injury or death.

Mount a New Tire

Mounting a Tire is the process of putting a Tire onto a Wheel.

⚠ WARNING Mounting a new Tire can be hazardous if not done correctly. Do not change a Tire unless you have been trained to do so. Failure to understand and follow proper procedures can result in injury or death.

During mounting, the Tire Bead goes over the Mount Lip of the Mount/Demount Head but stays under the Demount Lip. See **Mount/Demount Heads** for additional information.

Review the following points before mounting a Tire:

- Check the Tire and Wheel to make sure they are an **exact** match.
- If desired, replace the Wheel's Valve Stem before mounting the Tire.
- Consider using the Alloy Steel Mount/Demount Head, as it has a built-in Roller that helps to keep the Sidewall of the Tire stay under the Mount/Demount Head.
- Make sure the Wheel is both clean and free of balancing weights. Remove any weights and any corrosion you find on the Wheel; **do not** service heavily corroded Wheels.
- Check the Tire for damage; **do not mount a damaged Tire**.
- Check the location of the TPMS and adjust the Tire if necessary. Do not damage the sensor.
- Check for yellow and red dots. If found, line them up with the appropriate locations on the Tire.
- Make sure the Tire is **fully** deflated.

When mounting a Tire, you mount the bottom Bead first, then the top Bead.

To mount a Tire:

1. Make sure you are wearing OSHA-approved (publication 3151) personal protective equipment: leather gloves, steel-toed work boots, back belts, hearing protection, and ANSI-approved eye protection (safety glasses, face shield, or goggles).
2. If the Wheel is not already secured on the Turntable with the Narrow Side facing up, move the Wheel onto the Turntable and secure internally or externally.
3. Apply Tire lubricant to the top and bottom Beads and the top and bottom Rims.
4. Put the Tire over the Wheel, with the side that will be next to the Mount/Demount Head low and the other side high (above the top of the Wheel).
5. Swing the Mount/Demount Head into position.
6. Bring up the low side of the Tire and put the **bottom** Tire Bead over the Mount Lip and under the Demount Lip.

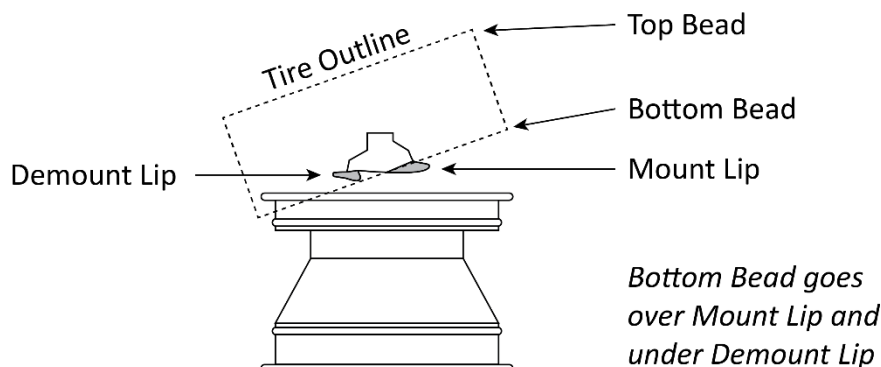

Side view. Not to scale.

7. Push the side of the Tire furthest away from the Mount/Demount Head down over that side of the Rim and Wheel as far as it will go.
8. Press down on the Turntable Foot Pedal.

The Turntable will turn clockwise, and the bottom Tire Bead will drop over the top of the Rim.

9. Put the **top** Tire Bead over the Mount Lip and under the Demount Lip.

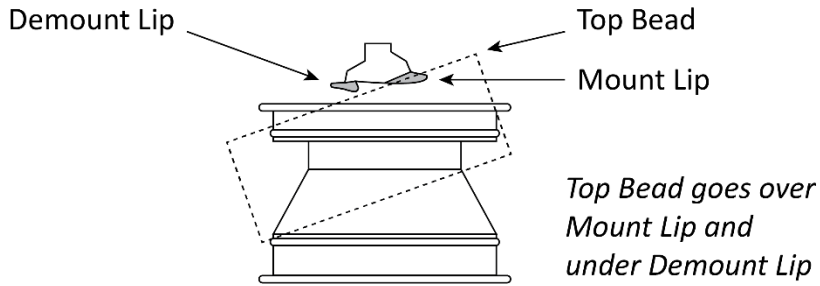

10. If using the Alloy Steel Mount/Demount Head, swing the built-in Roller into position on the Sidewall of the Tire.
11. If using the R980XR, position the Bead Lifting Tool to the left of the Mount/Demount Head (about 20 percent of the distance around the Tire), with the Bead Lifting Tool pushing down on the Sidewall of the Tire.

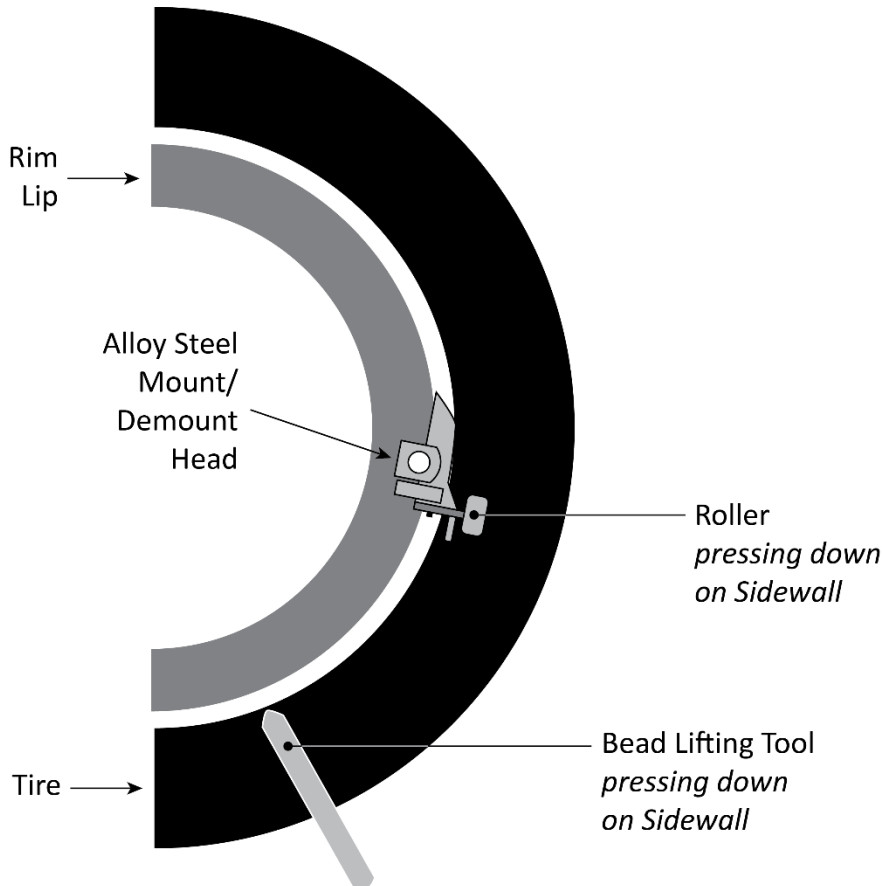

12. When you start rotating the Tire, move the Bead Lifting Tool around as the Tire moves around, keeping the Tool at the same spot on the Tire.

13. If using the R980AT, position the Assist Tool to the left of the Mount/Demount Head (about 20 percent of the total distance around the Tire), with the Assist Tool pushing down on the Sidewall of the Tire.

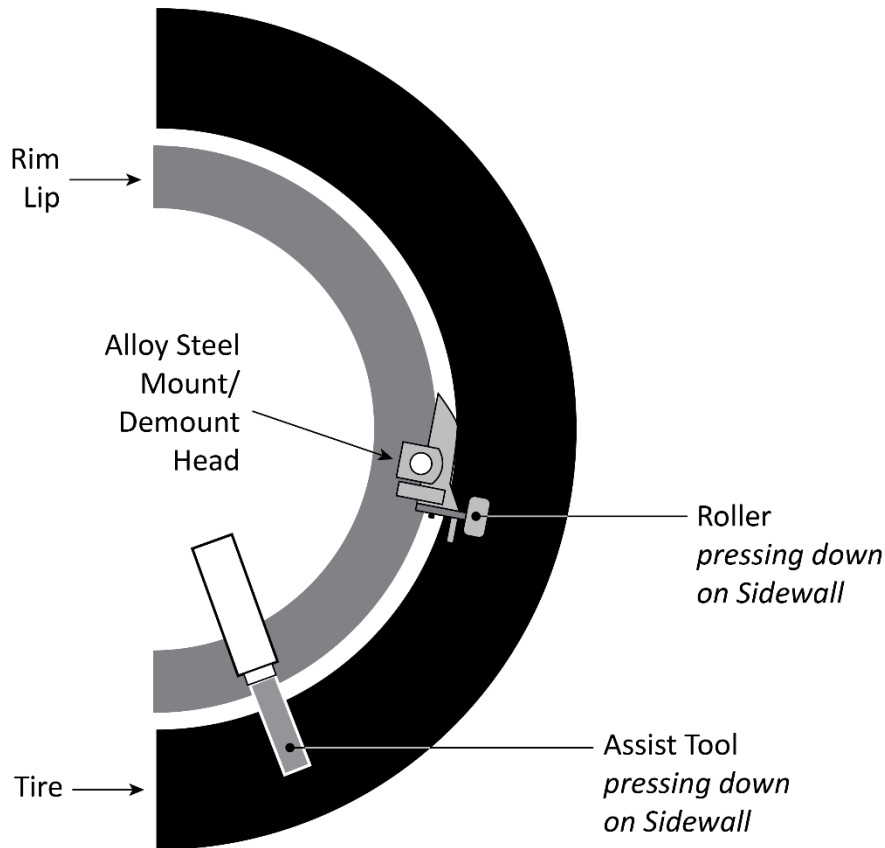

Top view. Not to scale.

When you start rotating the Tire, move the Assist Tool around as the Tire moves around, keeping the Tool at the same spot on the Tire.

14. Press down on the Turntable Foot Pedal to move the Turntable clockwise.

If using the Bead Lifting Tool or Assist Tool to hold down the Sidewall starting near the Mount/Demount Head, move them around with the Tire as it rotates.

15. If you run into any difficulty as the Tire rotates, take your foot off the Turntable Foot Pedal to stop the Turntable, then press up on the Turntable Foot Pedal to turn the Turntable counterclockwise. Make any necessary adjustments and then proceed.

Eventually the top Tire Bead slips under the Rim. How long this takes can vary, based on the Tire you are mounting.

The Tire is now in place around the Wheel Rim. The next step is to inflate the Tire.

Inflate the Tire

Tire inflation has three stages:

- **Bead sealing** is putting in a small amount of air pressure to push the Tire up against the Rim so the rest of the air you put in does not leak out. *Remove the Valve Core before beginning the Bead sealing*, as that allows more air to go in through the Valve Stem. Remember to put the Valve Core back in once both Beads are seated (before inflation). If you have difficulty sealing the Beads (you hear air escaping from between the Tire and the Rim), you can use the Turbo-Blast™ nozzle.
- **Bead seating** is putting more air pressure into the Tire until you hear a “pop”, which indicates the Beads (on both sides of the Tire) have slipped over the Bead Humps into their Bead Seats. *Put the Valve Core back in once the Beads are seated.*
- **Inflation** is adding more air pressure to the Tire to get the pressure up to the manufacturer’s recommended pressure for the Tire. **Do not stand over the Tire when inflating it.**

Each of these stages is covered separately below.

CAUTION The inflation process can produce noise. Wear ear protection when inflating a Tire.

WARNING Do not exceed the maximum air pressure specified by the Tire manufacturer. This increases the chances that the Tire could explode, causing injury or even death to the Operator and bystanders.

Use the Pressure Gauge on the Tire Changer to monitor the air pressure in the Tire you are inflating.

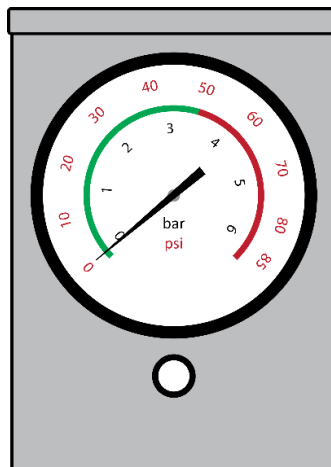

DANGER If you are inflating a Tire that requires more than 60 psi, you **must** use a **Tire Inflation Cage such as the RIC-4716** for safety purposes. If a Tire fails at high pressure, it can explode and cause serious injury or death to anyone near it. Using a Tire Inflation Cage helps reduce the danger.

Important inflation notes:

- Identify the **recommended** inflation pressure of the Tire (usually located on a sticker on the driver-side doorjamb) and the **maximum** inflation pressure of the Tire (usually located on the sidewall). When inflating, your goal is the recommended inflation pressure; do not exceed the maximum inflation pressure when inflating the Tire.
- Make sure the Tire is restrained for inflation: either *internally* clamped, held down by a Restraint Cone (R980AT only), or in a Tire Inflation Cage. Do not inflate a Tire if it is **externally** clamped; external clamping interferes with inflation.

Bead Sealing

To seal a Tire's Beads, you put a small amount of air pressure into the Tire, which pushes the Tire up against the Rim so that additional air you put in does not leak out.

To Seal the Beads:

1. Make sure you are wearing OSHA-approved (publication 3151) personal protective equipment: leather gloves, steel-toed work boots, back belts, hearing protection, and ANSI-approved eye protection (safety glasses, face shield, or goggles).
2. Make sure the Valve Core has been removed.
3. Clip the Air Chuck to the Valve Stem.

The Air Chuck includes a self-gripping clip, so you do **not** have to hold it in place during inflation.

⚠ WARNING ***Do not hold the Air Chuck while you are inflating a Tire.*** This leaves you close to the Tire, which could result in injury if there is a problem during inflation.

4. Press and hold down the Inflation Foot Pedal for a second or two.

Air goes into the Tire and seals the Bead.

Bead Sealing takes very little air pressure, anywhere from 0 to 3 psi, which you can monitor on the Pressure Gauge.

You know the Bead is sealed when you no longer hear the sound of air coming out from between the Wheel Rim and the Tire Beads.

5. Check to make sure the upper and lower Beads are sealed against the Rim.

If the Beads are **not** sealed, try again, this time putting in slightly more air.

6. If the Bead is still not sealed, position the Turbo-Blast™ nozzle about an inch from where the Wheel meets the Rim Edge and press the Button. You want the air blast to go under the Rim and into the Tire, sealing the Bead.

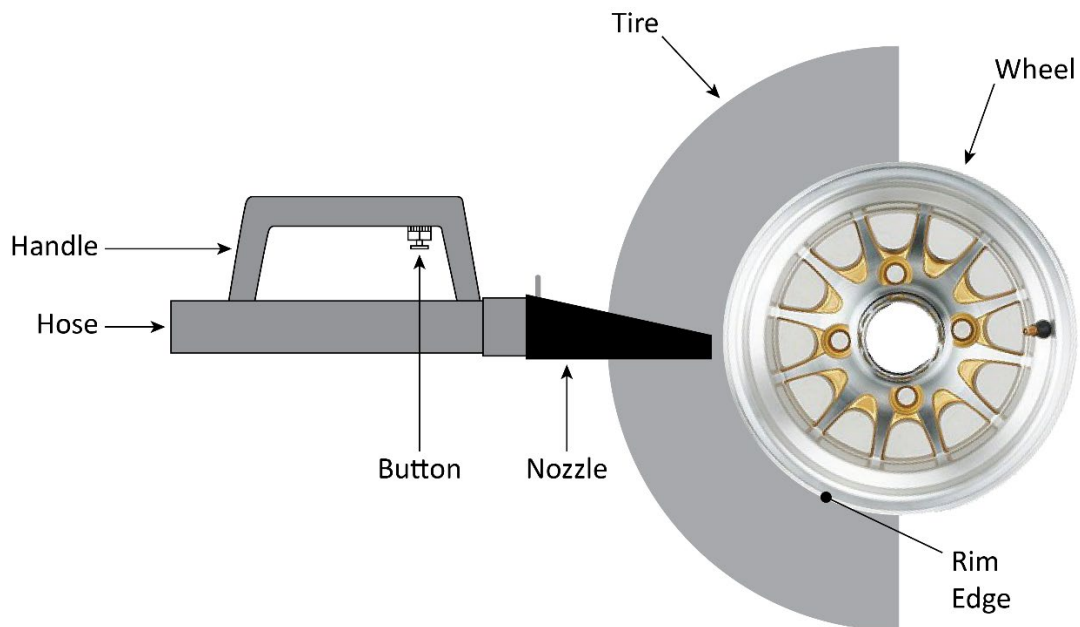

Side view shown; nozzle must be held flat to use. Not to scale. Not all components shown.

Bead Seating

To seat a Tire's Beads, you put in additional air pressure until you hear a "pop", which indicates the Tire Beads have slipped over the Bead Humps into their Bead Seats.

Remember that a Tire has Beads on *both sides* of the Tire. The Beads must be seated on both sides. Bead Seating is not complete until the Beads are seated on both sides of the Tire.

⚠ WARNING ***Do not exceed 40 psi to seat a Bead.***

The following procedure assumes the Tire's Beads have already been sealed. Do not try to seat the Beads until the Beads have been successfully sealed.

To Seat the Beads:

1. Make sure the Air Chuck is clipped to the Valve Stem of the Tire.
2. Step back from the Tire.
3. Press and hold down the Inflation Foot Pedal.

Air begins flowing into the Tire.

After a few seconds, you should hear a "pop" as the Beads are seated.

Bead Seating usually requires 7 psi or above.

Some Beads are hard to seat, but never exceed 40 psi to seat the Bead.

If air pressure in the Tire gets to 40 psi but the Beads are still ***not*** seated, use the Pressure Relief Button to remove air down to about 5 psi and then try again to seat the Beads. If you lower the psi too far, you may lose the Bead seal and must do that again.

4. Release the Inflation Foot Pedal.
5. If the Beads do not seat on a second attempt, either:
 - get a different Tire
 - ask your supervisor for instructions
 - let all of the air out of the Tire and start again (seal the Beads and then attempt to seat the Beads again)
6. If the amount of air pressure it takes to seat the Beads exceeds the manufacturer's recommended psi for the Tire, use the Pressure Relief Button to remove air pressure from the Tire, bringing it back down to the recommended psi for the Tire.
7. When the Beads are seated, remove the Air Chuck from the Valve Stem and **reinstall the Valve Core**.

Inflating the Tire

To inflate a Tire after sealing and then seating the Beads, add air pressure to the Tire to get the pressure to the manufacturer's recommended pressure.

Use the Pressure Gauge to monitor air pressure; do not 'guesstimate' the psi.

⚠ DANGER If you are inflating a Tire that requires more than 60 psi, you **must** use a **Tire Inflation Cage such as the RIC-4716** for safety purposes. If a Tire fails at high pressure, it can explode and cause serious injury or death to anyone near it. Using a Tire Inflation Cage helps reduce the danger.

The typical inflation pressure for automobile Tires is from approximately 25 to 45 psi. Light truck Tire inflation pressures typically cover a wider range.

Do not exceed the Tire manufacturer's **maximum** air pressure for a Tire. Your goal is to get to the Tire's **recommended** pressure.

The Tire Changer has an air pressure limiter that is set at the factory so that it does **not** exceed 60 psi. **Do not override the pressure limiter.**

⚠ DANGER Inflating a Tire with a bypassed pressure limiter could result in the Tire exploding, which could injure or kill bystanders or the Tire Changer Operator. Do not exceed 60 psi unless the Tire is in a Tire Inflation Cage.

To inflate a Tire:

1. Verify that both the upper and lower Beads are sealed and seated.
2. Verify that the Valve Core has been put back in.
3. Make sure the Air Chuck is clipped to the Valve Stem of the Tire using the self-gripping clip.
4. Step back from the Tire.

⚠ DANGER Do **not** stand over the Tire when inflating it. If the Tire explodes during inflation (which does not happen often, but does happen), you could be injured or killed if you are standing over the Tire when it explodes.

5. Press and hold down the Inflation Foot Pedal.
Air begins flowing into the Tire.
6. Inflate the Tire to the manufacturer's **recommended** psi by monitoring the Pressure Gauge.
7. Release the Inflation Foot Pedal.
8. Remove the Air Chuck from the Valve Stem.
9. Take the Wheel off the Tire Changer.

Maintenance

Make sure your Tire Changer is maintained on a regular basis.

 **WARNING** Disconnect the Tire Changer from power and the incoming air from the Air Source **before performing any Maintenance**. Take whatever steps are necessary to make sure the unit cannot be re-energized until Maintenance is over (such as Lockout/Tagout). Because the unit uses electrical and pneumatic energy, you could be electrocuted or even killed if the unit is powered back on during Maintenance.

The Tire Changer uses pneumatic and electrical energy; if your organization has **Lockout/Tagout policies**, make sure to implement them before performing maintenance on the Tire Changer.

Regular Maintenance

- **Daily:** Make sure the unit is clean and dry.
- **Weekly:** Check all labels to make sure they are in place and legible. Contact BendPak Ranger if replacement labels are needed.
- **Weekly:** Check the water level of the Regulator/Filter. If the reservoir is one quarter (25%) or more filled with water, drain it. Refer to **Check the Water Level** for instructions.
- **Weekly:** Check the oil feed rate of the Oiler/Lubricator. It should be 1 to 2 drops per use of a pneumatic component. If it is above or below this level, you need to adjust it. Refer to **Check the Oil Feed Rate and Adding Oil** for instructions.
- **Weekly:** Check the amount of pneumatic oil in the Oiler/Lubricator reservoir. If it is under one half (50%) full, add oil. Refer to **Check the Oil Feed Rate and Adding Oil** for instructions.
- **Monthly:** Check the accuracy of the Inflation Gauge using a pressurized tire and a high-quality pressure gauge. Fix immediately if not working correctly.
- **Monthly:** Make sure all Anchor Bolts are tightened and secure, if used.
- **Monthly:** Make sure all components are in good operating condition. If you find a component that is **not** working correctly, take the Tire Changer out of service and refer to **Troubleshooting** for more information.
- **Twice a Year:** Have a licensed Electrician check the electronic components.
- **Yearly:** Take the Tire Changer out of service, disconnect the Power Cord from the power source, and then thoroughly check and clean all components.

 **WARNING:** Do not operate your Tire Changer if you find issues; instead, take the unit out of service, then contact your dealer, visit www.bendpak.com/support/, or call **(805) 933-9970**.

Check the Water Level

Water coming in from the Air Source is pulled out of the incoming air by the Regulator/Filter and dropped into the reservoir at the bottom.

This water needs to be drained periodically.

To drain water from the Regulator/Filter reservoir:

1. Check the Water Sight Gauge to see how much water is currently in the reservoir.
If the reservoir is one quarter (25%) or more filled with water, you need to drain it.
2. Disconnect the Air Source at the Air In connector.

⚠ WARNING Make sure to disconnect the Air Source and make sure it cannot be reconnected until you are done draining the water from the Regulator/Filter. If the Air Source is reconnected during the procedure, it could damage the Regulator/Filter, the Tire Changer, and possibly injure bystanders.

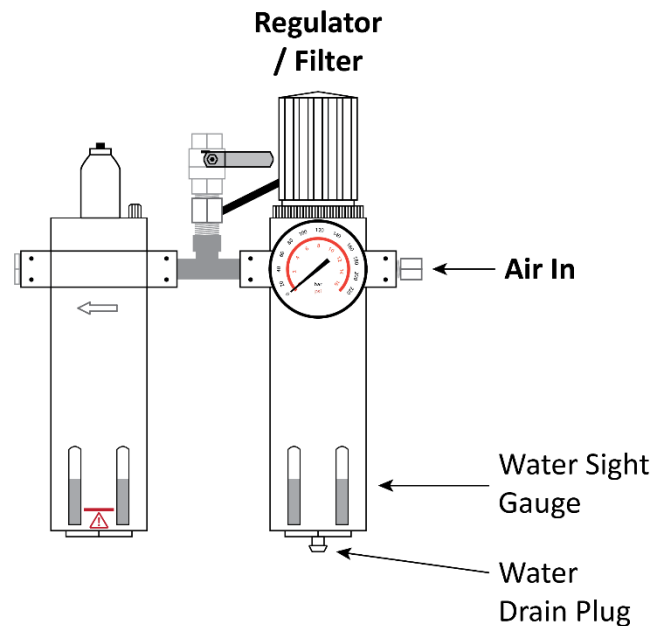

3. Press upwards on the Water Drain Plug at the bottom of the reservoir.
The water drains out.
4. Release the Water Drain Plug.
5. Re-connect the Air Source.

Check the Oil Feed Rate and Adding Oil

The built-in lubricator adds pneumatic oil to the incoming air. This ensures that all pneumatic components of the Tire Changer receive the necessary lubrication, which maintains operating performance, reduces wear, and extends service life.

It is very important to make sure the oil feed rate is correct, 1 or 2 drops of oil per use of pneumatic component (such as the Clamps Foot Pedal), and that there is enough pneumatic oil in the Oil Reservoir of the Oiler/Lubricator.

To check the oil feed rate on the Oiler/Lubricator:

1. With the Air Source connected, press up or down on the Clamps Foot Pedal for several seconds, then release.

You do not need a Tire; you just need to use a pneumatic tool.

2. Watch the Sight Glass to see how much pneumatic oil comes out each time you press up or down on the Clamps Foot Pedal.

Your goal is for 1 or 2 drops to come out each time.

3. If you are getting **fewer** than 1 or 2 drops, turn the Adjustment Screw counter-clockwise (using a small flat-head screwdriver), then press the Clamps Foot Pedal again to check the output.
4. If you are getting **more** than 1 or 2 drops, turn the Adjustment Screw clockwise, then press the Clamps Foot Pedal again to check the output.
5. When you are getting 1 or 2 drops, stop turning the Adjustment Screw.

To add pneumatic oil to the Oiler/Lubricator:

1. Check the Oil Sight Gauge to see how much pneumatic oil is currently in the reservoir.

If the reservoir is less than one half (50%) filled with pneumatic oil, you need to add oil to it.

2. Disconnect the Air Source at the Air In connector.
3. Turn the Oil Fill Cap on the top of the Oil Reservoir counterclockwise and pull it off.
4. Add SAE 10W Air Tool Oil or generic pneumatic oil to the reservoir.
5. Put the Oil Fill Cap back in place, turning it clockwise until tight.
6. Re-connect the Air Source.

Troubleshooting

⚠ WARNING: Disconnect the Power Cord from power and the incoming from the Air Source **before performing any maintenance.** Take whatever steps are necessary to make sure the unit cannot be re-energized while maintenance is being performed on it (such as Lockout/Tagout). The unit uses pneumatic and electrical energy; if your organization has Lockout/Tagout policies, make sure to implement them before troubleshooting the Tire Changer.

Issue	Action to Take
The Turntable does not move when you step on the Turntable Foot Pedal.	Make sure the unit is getting power.
The unit is not getting power.	Have a licensed, certified Electrician check the electrical path from the supplied cord to the power source. If any issues are found, have them repaired. Refer to Wiring Information for additional information.
No air comes out of the Air Hose when you step on the Inflate Foot Pedal.	Make sure the unit is correctly connected to a working Air Source.
It is difficult to secure Tires when clamping externally.	Use the Restraint Cone to press the Tire down so the Clamps correctly grab the Rim of the Wheel.
The Inflation Gauge is not working correctly.	Check the accuracy of the Inflation Gauge with a professional gauge. Fix immediately if the Inflation Gauge is not working correctly.
The Assist Arms (R980 only) move up and down slowly or make odd noises when moving.	Grease the Assist Tower Post, it has run out. Refer to Grease the Assist Tower Post for more information.

If you continue to have problems with your Tire Changer, visit www.bendpak.com/support/ or call **BendPak Ranger at (805) 933-9970.**

Wiring Information

The Tire Changer comes with a Power Cord that is connected inside the unit on one end and with three exposed wires on the other end (called a 'pigtail'). The three exposed wires need to be hard-wired to the facility's power system or connected to a 250 VAC, 30A, 2-Pole, 3-Wire, NEMA rated plug (which is then connected to a power outlet). The electrical supply to the R980 must be protected by an appropriate fuse or circuit breaker.

⚠ WARNING: All electrical work, such as hard wiring the unit to the facility's power system or attaching a Plug to a Power Cord, **must be done by a licensed, certified Electrician** in accordance with all applicable national and local electrical codes. Damage to the unit caused by improper electrical installation voids your warranty.

The Tire Changer does **not** come with a 250 VAC **Plug**; you must supply one.

The colors of the three exposed wires are Brown, Blue, and Green/Yellow, the European color code.

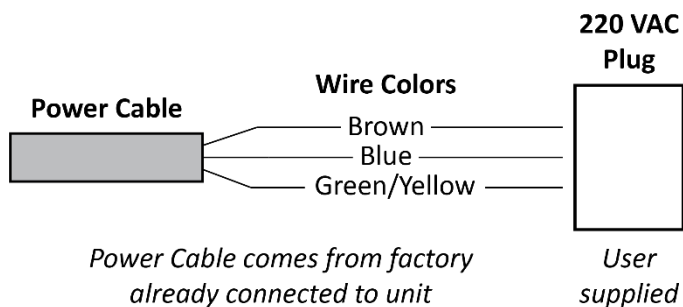

Important: To connect the three exposed wires to an appropriate Plug or to hard wire them, have your Electrician follow the electrical codes for the country in which you are using the unit and any local electrical codes.

For example, if you are using the unit in the United States, the color codes on the wiring that comes with the Tire Changer correspond to:

- **Brown:** Live
- **Blue:** Live
- **Green/Yellow:** Ground

If you were using the unit in a European country, the color codes on the wiring that comes with the Tire Changer correspond to:

- **Brown:** Live
- **Blue:** Neutral
- **Green/Yellow:** Ground

Information about color code conventions in other regions and countries is available online. Make sure your Electrician installs the Plug in accordance with all applicable local electrical codes.

Labels

A



R980AT version. R980XR says "R980XR".

B

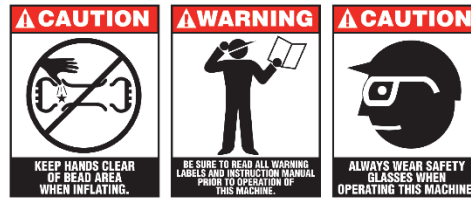

C



D

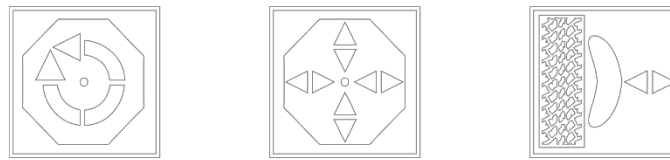

E



F



G



H



I



J



K



L

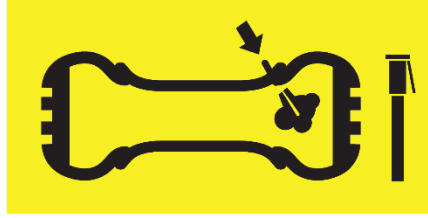

M**N****O**

POWER ASSIST

P

⚠ IMPORTANT - PLEASE READ

FILTER / REGULATOR LUBRICATOR INSTRUCTIONS

WARNING!
Failure to regularly drain water and maintain proper oil level and oil feed rate will damage internal pneumatic components and void product warranty.

The inline lubricator helps ensure that all pneumatic components inside this machine receive the required lubrication to maintain operating performance, reduce wear and prolong service life. It is designed to automatically provide the correct amount of oil feed rate required within the pneumatic system delivering a constant ratio of oil to CFM.

The filter/regulator is designed to remove airborne solid and liquid contaminants which may plug small orifices and hinder performance or cause excessive wear and premature equipment failure. The regulator provides controlled and consistent air pressure as required. **NOTE:** This model requires 15-25 CFM air source with a safe operating air pressure of 140-165 PSI for optimum machine performance.

Water Separator / Lubricator Maintenance

- Check oil and water levels regularly and perform these maintenance items weekly.
- Observe the water sight gauge on the water separator/filter unit. If water is observed, drain by pressing upwards on the drain plug at the bottom of the reservoir.
- Observe the sight glass and adjust the oil feed rate by turning the small adjustment screw on the top of the glass bowl so that 2-3 drops of oil drip through the site glass for each operation of the bead loosener pedal.

Adding Oil to Oiler / Lubricator

If oil level is low, add oil as follows:

1. **IMPORTANT** - First disconnect air source from machine.
2. Remove oil reservoir by unthreading reservoir from head of oiler/lubricator.
3. Add oil as necessary.

4. Replace reservoir making sure rubber O-ring is seated properly and reservoir is firmly tightened hand-tight.

Regulator / Filter

Oiler / Lubricator

PH38603

Q

Use Moly-Graphite Grease to ensure proper lubrication of slide plates.

PH 5900596

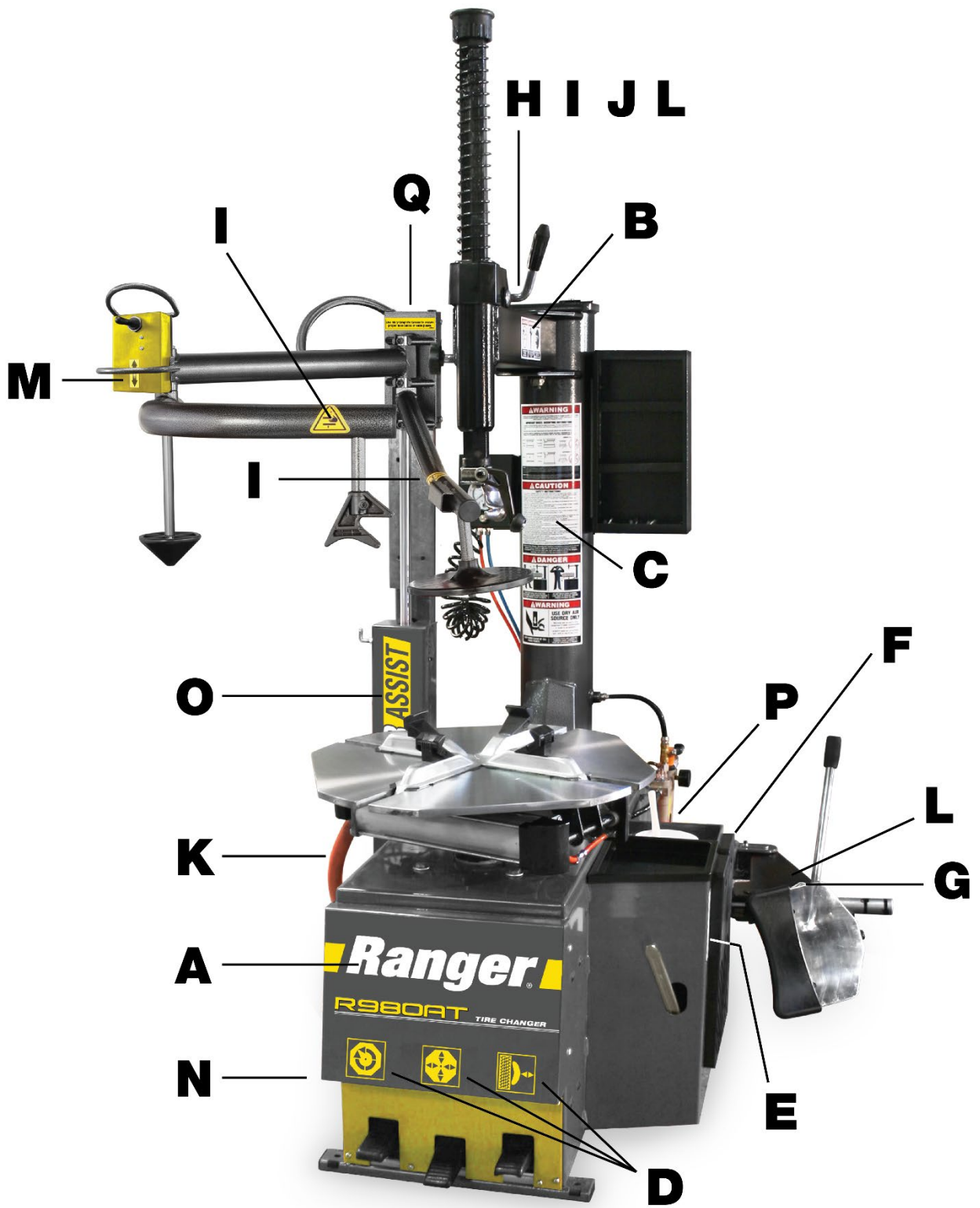

Parts

Cabinet

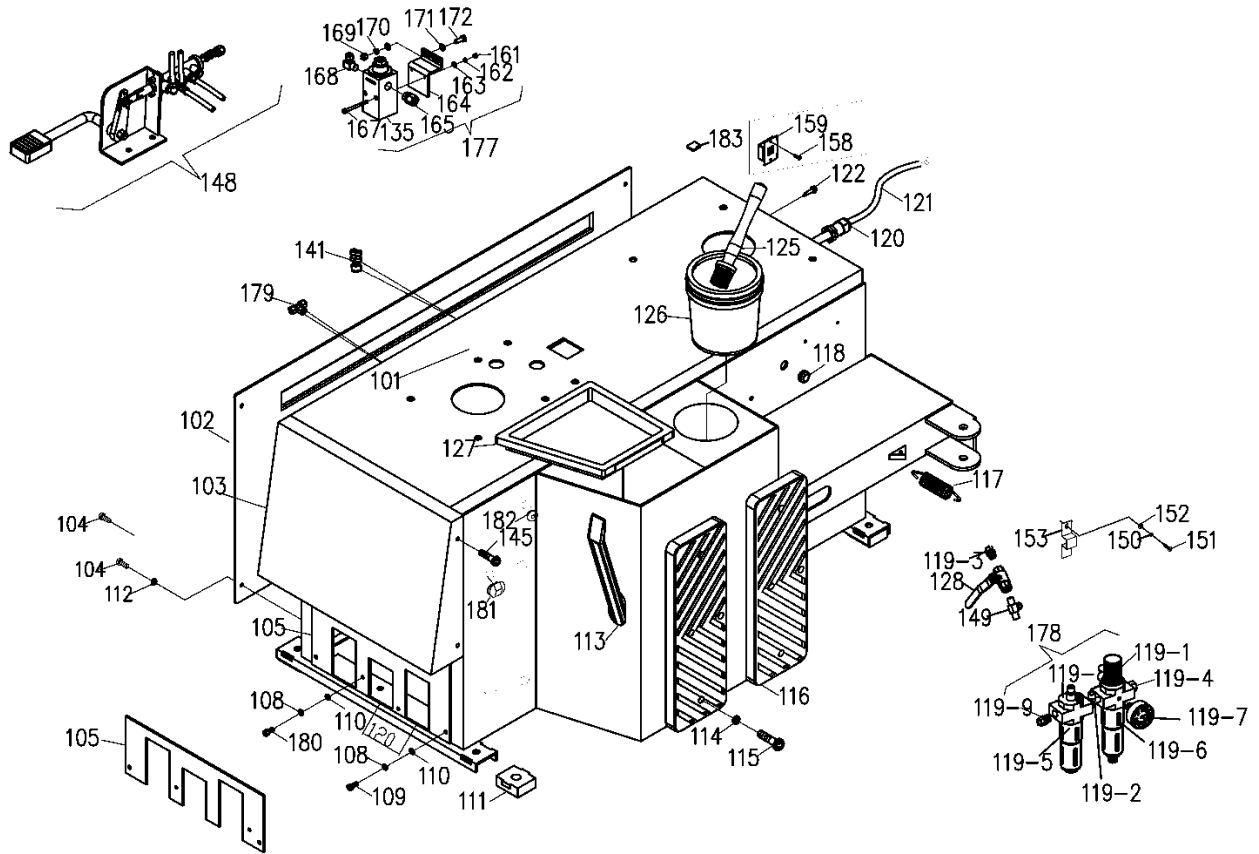

Number	Part Number	Description
101		Container weldment
101		Container weldment
102	5327673	Side Cover
103		Container front face weldment
104		Socket head cap screw M6 x 16
104		Large flat head screw with cross groove
105	5328066	Chassis front board (A)
105		Chassis front board
108		Washer; M6 x 12 mm Flat
109		Socket head cap screw M6 x 12
110	5400913	Washer; M6 flat
111	5327307	Plastic Foot Pad; I Models
112	5400913	Washer; M6 Flat
113	5400110	Pry bar
114		Washer M6
115		Cross recessed round head screw M6 x 25
116	5327614	Wheel Support Pad
117	5327309	Bead breaker Return Spring; R745/R30XLT
118		Cable holder ϕ 12
119-1	5327846	Yellow Air Regulator/Dryer; I Models

119-2	5327806	Fitting; 1/4 x 1/4 Tee
119-3		Fitting G1/4" ϕ 12
119-4		Tower straight in G1/4" -G1/4"
119-5	5327684	Oiler cup
119-6	5327685	Filter cup
119-7		Air pressure gauge
119-8	5327847	Yellow Air Oiler; I Models
119-9		Fitting G1/4" ϕ 12 Straight
120		Rubber cord grip
121	5401121	Power cord
121		Power cord
122	5327530	STS M 5.5 x 25
125	5400121	Soap brush
126	5400120	Soap bucket
127	5327672	Tool Tray
128	5327671	1/4" Ball Valve
135		Full flow inflation regulator
141	5327558	Fitting 8 mm Y
145		Cross recessed round head screw M6 x 10
148	5328139	Inflation Foot Pedal Assy
149	5327824	Tee union G1/4"- ϕ 8-G1/4"
150		Washer; ϕ 4; Spring
151		Cross recessed round head screw M4 x 12
152		Washer; ϕ 4 flat
153	5328278	Air/Oil regulator support
158		Cross recessed round head screw M4 x 16
159		
161		Nut M4
162		Washer; ϕ 4; Spring
163		Washer; ϕ 4 flat
164		Full flow inflation kit bracket
165		Fitting; G1/4" ϕ 8
167		Socket head cap screw M4 x 50
168		Fitting; 90° G1/4" ϕ 8
169		Nut M6
170		Washer; ϕ 6; Spring
171		Washer; ϕ 6 flat
172		Hexagon headed bolt M6 x 20
177		Pneumatic valve department
178	5328220	Air/Oil regulator assy
179		Tee joint union ϕ 8- ϕ 8- ϕ 8
180		Cross recessed round head screw M6 x 20
181		Blind
182		Round Board
183		Plug
184		carton

Main Tower

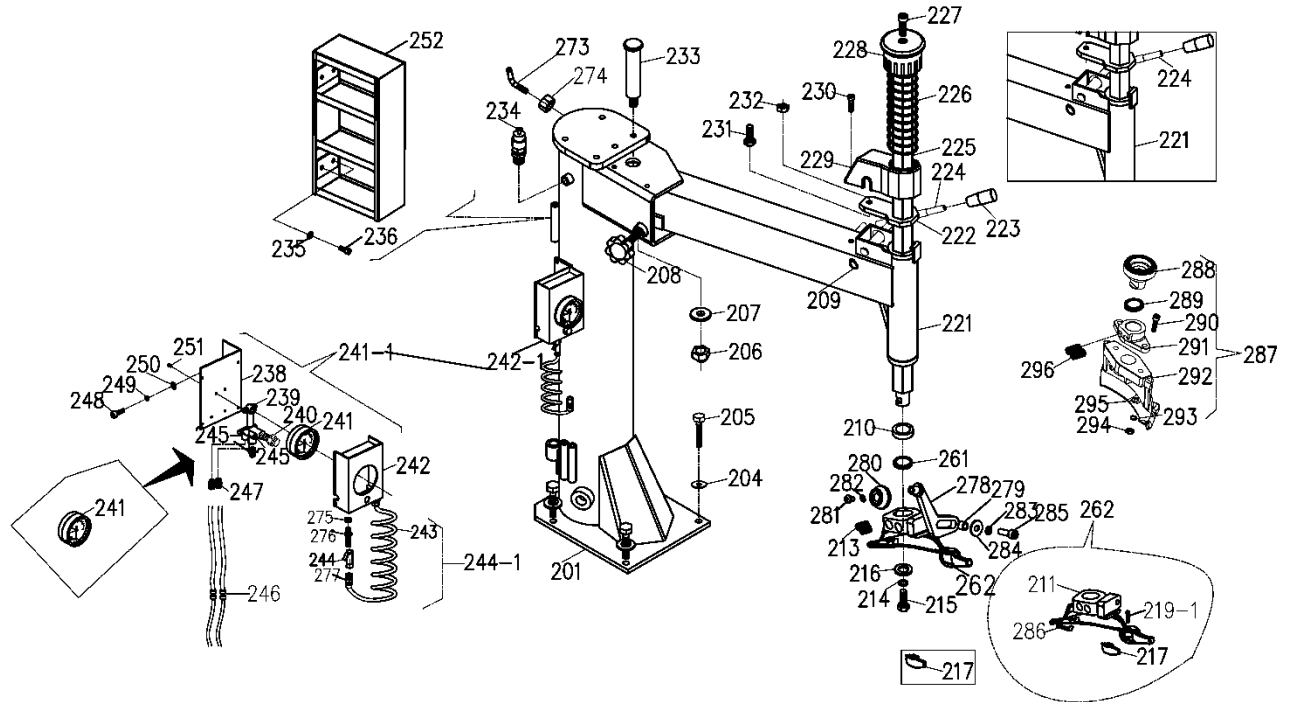

Number	Part Number	Description
201	5601102	Tower unit weldment
204		Washer; M12 x 24
205		Hexagon headed bolt M12 x 60
206		Locknut M16
207		Lock pad
208	5401222	Swing Arm Adjustment Screw with Knob
209	5404141	M18 Snap Ring
210	5327310	Mount / demount head $\phi 46 \times 34 \times 12$
211	5328198	Metal Duckhead
213	5327468	M12 x 16 Duckhead Set Screw; I Models
214		Washer $\phi 10$
215		Hexagon headed bolt M10 x 20
215	5327729	Hexagon headed bolt M10 x 30
216	5327436	Duckhead Insert
217	5327636	Roller Insert; I Models
217	5327636	Roller Insert; I Models A
218	5327439	Slide wheel
219-1		Screw
221	5328232	Swing arm unit weldment
221	5328232	Swing arm unit weldment A
221	5328232	Swing arm unit weldment A
222	5327667	Locking Plate
222	5327667	Locking Plate; R30XLT (A)
223	5327617	Locking Handle Knob
224	5327618	Locking Handle
224	5327618	Locking Handle
224	5327618	Locking Handle

225	5327619	Vertical Shaft
226	5400237	Hex Shaft Spring; B & I Models
227	5400942	Socket head cap screw M10 x 25
228		Hex shaft cap
229	5327620	Hex Shaft Lock Cover
230		Socket head cap screw M6 x 30
231		Hexagon headed bolt M10 x 25
232		Thin nut M10
233	5327359	Swing arm pivot pin
234	5327449	Pressure Release Valve; I Models
235	5400913	Washer; M6 flat
236		Socket head cap screw M6 x 16
238		Inflator Assy Base; I Models
239		Tire Inflator Relief Valve; I Models
240		Air Release Valve; I Models
241	5327769	Inflating gauge
241	5327769	Inflation gauge; I Models Damp
241-1		Inflation System Assy
242		Inflation System Plastic Cover; I Models
242-1	5327463	Tire Inflator Box Assy; I Models
243		Coiled Hose;
244	5327538	Air Chuck; I Models
244	5327538	Air Chuck; I Models
244-1	5327130	Inflation Hose Assy; I Models
245		Block G1/8"
245-1		Air Chuck; I Models G1/4"-G1/8"
246	5327558	Fitting 8 mm Y
247	5328122	Fitting G1/8" ϕ 8 Straight
248		SHCS M6 x 10
249		Washer ϕ 6
250		Washer; ϕ 6 flat
251		Cross recessed round head screw M3 x 10
252	5327173	Toolbox
253		Nut M8
254		Washer M8
255		SHCS M8 x 35
261		Duckhead adjust pad
262		Mount/demount head assy
273	5327472	Turbo blast hook
274	5327884	Nut M8
275	5328119	Nut M6
276		Inflation hose plug
277		Fitting G1/8" ϕ 8
278		Tire pressure arm
279		Arm axes
280		Plastic BB roller
281		Cross recessed round head screw M6 x 10
282		Washer ϕ 6 x 1.6
283		Washer ϕ 8
284		Washer ϕ 8 x 2

285		SHCS M8 x 25
286	5328119	Duckhead Insert (A)
287	5327880	Plastic components of bird head
288		Quick change head fixed set of bird
289		Pad
290	5327883	SHCS M8 x 45
290		SHCS M8 x 40
291		Plastic bird head flange
291	5328289	Plastic head flange
292	5150523	Plastic head of A bird
293	5545202	Washer; M8 x 15 LW
294	5327884	Nut M8
295	5402104	Washer; M8 x 16 flat
296		Hexagon inner flat end set screw

Turntable

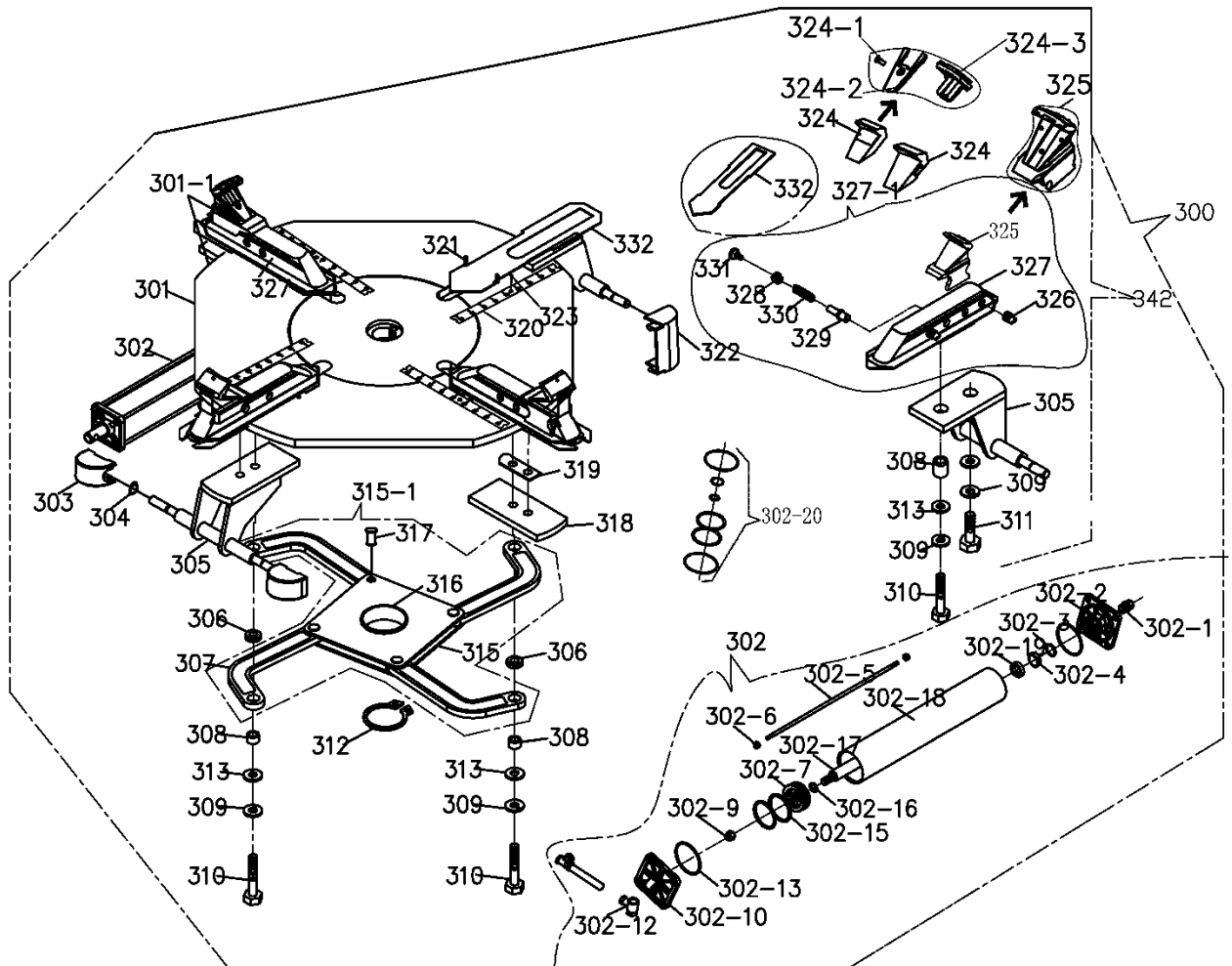

Number	Part Number	Description
300	5327465	Turntable plate assy
300		Turntable plate assy
301	5327713	Turntable plate welding
301-1		Turntable plate assy

302	5327300	Jaw clamp cylinder
302-1	5327475	Fitting; G1/8 8 mm
302-2	5327365	Small Front Cylinder Cover; I Models
302-3	5327487	O-Ring 25 x 3.1; I Models
302-4		Jaw Clamp Cylinder Wear Strip; I Models
302-5	5401421	HHB M8
302-6		Locknut M8
302-7		Small Cylinder Piston; I Models
302-9		Locknut M12
302-10	5327364	Small Rear Cylinder Cover; I Models
302-11		Locknut tee
302-12	5400459	Union G1/8" elbow
302-13	5327488	O-Ring 75 x 2.65; I Models
302-15	5327489	O-ring 75 x 5.7
302-16	5327486	O-ring 16 x 2.4; I Models
302-17		Jaw clamp cylinder rod
302-18	5327406	Jaw clamp cylinder body
302-19	5327494	Y-Ring 32 x 20 x 6; I Models
302-20		Seal ring
303	5327305	Small cylinder cover; I Models
304	5400905	Snap ring 12 mm
305	5327471	Slide Guide
306	5327735	Square Turntable Slide Rod Pad
307		Square Turntable Link
308	5327500	Square Turntable shaft sleeve
309		Washer 12 mm spring
310		HHB M12 x 50
311		HHB M12 x 25
311		HHB M12 x 25
312		Snap ring 65 mm
313		Washer; M12 x 24
315		Square Turntable main board
315-1	5327450	Square Turntable assy
316		Square Turntable Spacer
317	5327521	Square Turntable Press Pin
318	5327542	Slave Slide Guide
319	5327461	Slide Shim Adjustment; I Models
320		Turntable Ruler
321		Split pin
321		Split pin
322	5327306	Large cylinder cover
323		Turntable Ruler Screw; M4 x 6
324	5327081	Jaw Clamp Cover Set; I Models (quantity 4)
324	5328234	Jaw Clamp Cover Set; I Models (quantity 4)
324-1	5328310	Stainless steel hex socket countersunk head screws M4 x 10
324-2	5328312	Plastic Mattress for jaw clamp
324-3		Rubber blanket for jaw clamp
325	5327404	Jaw Clamp; R23/26/980 (I)
325	5328311	Jaw Clamp; I Models Rev-A W/Rubber Insert
326	5328400	special screw M10 x 1

327	5327405	Jaw Clamp Support; R23/26/980 (I)
327	5328306	Jaw Clamp Support; R76/980
327-1		Jaw Clamp Support assy
328	5327630	Jaw Clamp Inner Adjustment Knob
329	5327621	Jaw Clamp Inner Adjustment Pin
330	5327662	Jaw Clamp Pin Spring
331	5327623	Jaw Clamp Locking Pin
331	5327623	Jaw Clamp Locking Pin
332	5328328	Boat gasket
342		Turntable assy (B) cylinder bracket assembly

Bead Breaker

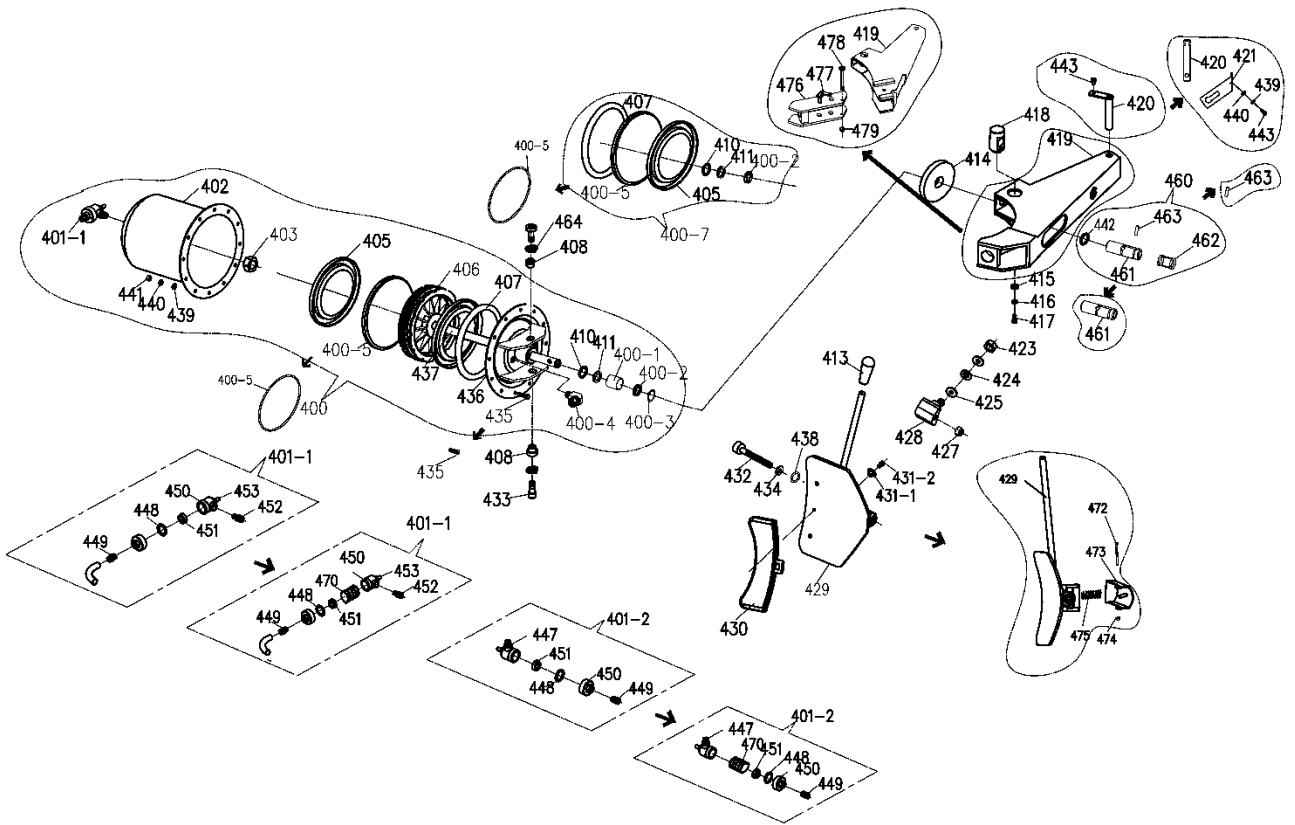

Number	Part Number	Description
400	5327664	Bead Breaker Cylinder Assy
400-1		Oil Bearing $\phi 23 \times \phi 20 \times 20$
400-2		Seal ring $\phi 30 \times 20 \times 7$
400-3		Type I Hole With Elastic Ring $\phi 32$
400-4		Fitting; $90^\circ G1/4" \phi 10$
400-5		Guide Ring
400-5		Guide Ring
400-7		Pairs of large cylinder seal hair accessories 201
401-1	5327605	10 mm x 1/4 BB Flow Control Valve
401-1	5327459	12 mm x 1/4 BB Flow Control Valve
401-2	5327395	10 mm x 10 mm BB Flow Control Valve
401-2	5327815	12 mm x 12 mm BB Flow Control Valve
402		Cylinder liner

402		Cylinder liner
403		Nut M18 x 1.5 - Thin threaded
404		Piston limit bowl
405	5327682	Y-Ring Ø200 x 12 x 6 mm
406	5327413	BB Cylinder Piston; I Models
407	5327537	O-Ring; 193 x 5.7; I Models
408	5328078	Eccentric Bushing; I Models
410	5327487	O-Ring; ϕ 25 x 3.1
411	5327493	Y-Ring ϕ 25
413		Bead Breaker Blade Handle
413	5327634	Bead Breaker Blade Handle
414	5327177	BB Rubber Disk; I Models
415	5545202	Washer M8 x 15 LW
416		Washer ϕ 8
417		Socket head cap screw M8 x 16
418	5327367	BB Arm Cylinder Pin
419	5327635	Bead Breaker Arm
419	5327635	Bead Breaker Arm
419		Bead Breaker Arm
420	5328132	BB arm pivot pin
420		BB arm shaft
421		BB arm shaft baffle
423		Locknut M16
424		Pad (wave) ϕ 16
425		Washer ϕ 16
427		Locknut M14
428	5327752	Bead Breaker Knuckle
428	5327752	Bead Breaker Knuckle
429	5327596	Bead Breaker Blade
429	5327768	Bead Breaker Blade
429	5327768	Bead Breaker Blade
430	5327082	Bead Breaker Blade Cover; I Models
431-1	5328083	Bolted BB Blade cover Bushing Assy (includes 431-2 Bolt)
431-2		SHCS M6 x 10 (Included on 431-1 Assy)
432	5327609	Socket head cap screw M14 x 95-12.9
433	5327981	Socket head cap screw M14 x 36
434		Washer ϕ 14
435		HHB M6 x 16
435		Hexagon headed bolt M8 x 16
436		Big cylinder flange unit weldment
436	5401520	Big cylinder flange unit weldment
437	5327677	BB Cylinder Rod
437		BB Cylinder Rod
438		Spring pad ϕ 14
439		Washer; ϕ 6 flat
440		Washer ϕ 6
440		Washer ϕ 8
441		Nut M6
441		Nut M8

442	5327487	O-Ring ϕ 25 x 3.1
443		Cross recessed round head screw M6 x 10
443		Cross recessed round head screw M6 x 10
447		Fitting; G1/4" 12 mm
448		Leather packing
448		Metal quick exhaust valve leather cushion
449	5327732	Fitting; G1/4" 12 mm
450		Quick exhaust valve
450		Metal quick exhaust valve
451		Quick drain valve bowl
451		Quick exhaust valve metal cup
452		Fitting; G1/4"-G1/4"
453	5327561	Silencer 1/4" NPT
460		Adjust the set of assembly
461		BB Blade Adjustment Rod
461		BB Blade Adjustment Rod
462		Adjust the collection
463		BB Blade Adjustment Rod Pin
463		BB Blade Adjustment Rod Pin
464		Washer ϕ 14
470		Metal quick exhaust valve spring
472		SHCS M8 x 85
473		Reseat installed and welded
474		Nut M8
475		Pressure spring
476		Shovel arm slide arm assembly
477		Spatula fixing pin assembly
478		SHCS M8 x 95
479		Locknut M8

Gearing

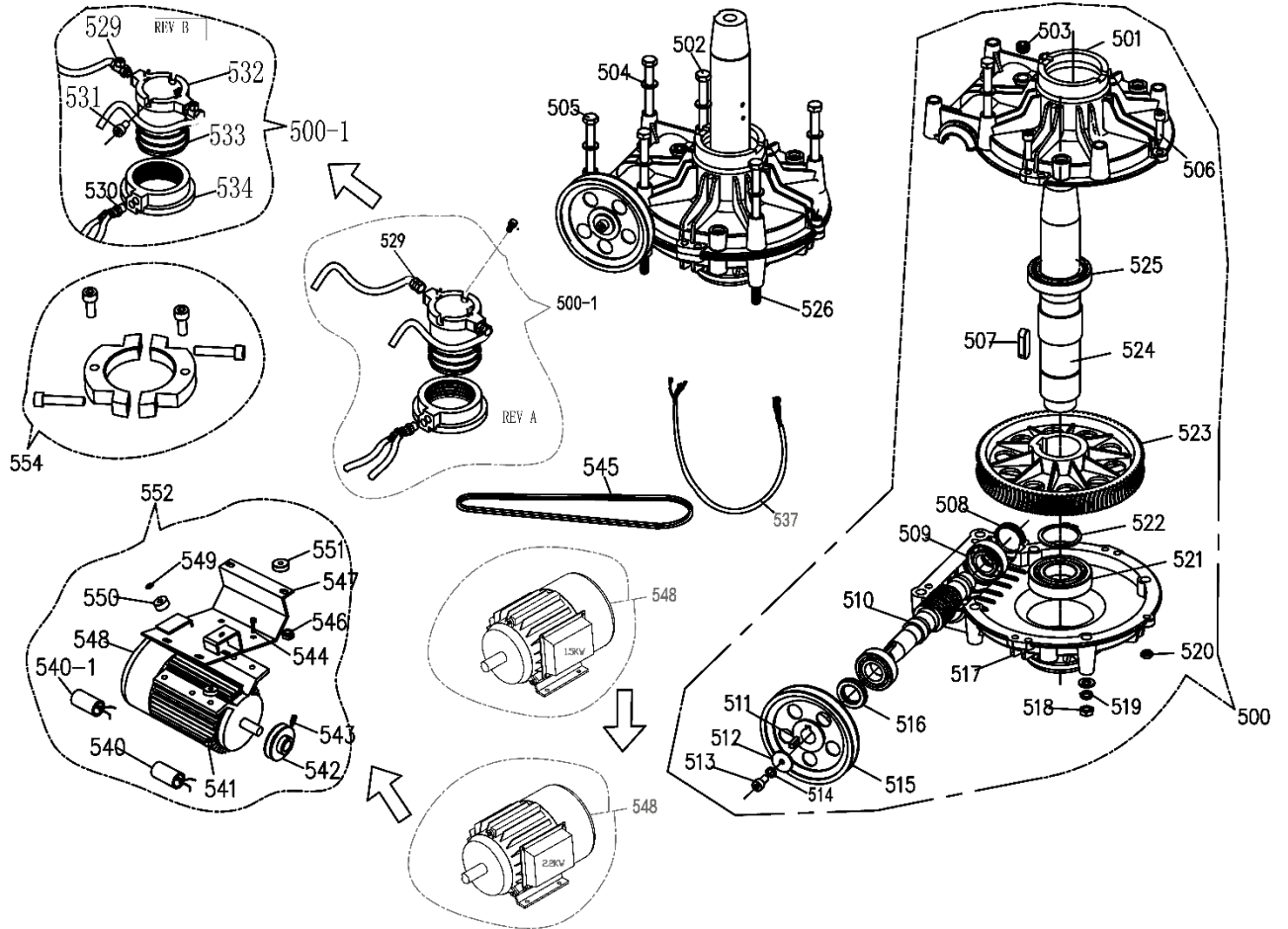

Number	Part Number	Description
500	5327479	Gearbox assy
500	5327479	Gearbox assy
500-1	5327175	Rotary valve assy
500-1	5327175	Rotary valve assy
501		Gearbox front flange
502	5327520	Hexagon headed bolt
503		Oil plug
504		Washer ϕ 10
505		Hexagon headed bolt M10 x 180
506		Socket head cap screw M8 x 30
507		Large gear key 12 x 8 x 35
508		Oil block 45 x 8
509		Cone roller bearing 6205
510		Gear stud m2
511		Tab 6 x 6 x 20
512		Gear stud pad
513		Socket head cap screw M8 x 16
514		Washer ϕ 8
515	5327976	Gear Box Pulley
516		Oil seal ϕ 45 x 25 x 10

517		Gearbox back flange
518		Nut M10
519		Washer ϕ 10
520		Nut M8
521		Bering 80208
522		Seeger ring ϕ 50
523		Helical gear m2 (Al)
524		Spline shaft
525		Bering 6010
526		Hexagon headed bolt M10 x 170
529	5327745	Fitting G1/8" ϕ 8
529	5328350	Fitting; ϕ 8- ϕ 8-G1/8"
530	5327745	Fitting G1/8" ϕ 8
531		Inner hexangular set screw M6 x 20
532		Rotary Joint Block Inner Piece; I Models
533		O-ring ϕ 60 x 2.75
534	5327355	Rotary Joint Block Outer Piece; I Models
537		Electrical line
540	5327819	Capacitor 450 VAC 50 MF
540-1		Start capacitor
541		Locknut M8
542	5327369	Motor Pulley; I Models
543		Hexagon socket set screw with flat point M8 x 16
544		Hexagon headed bolt M8 x 40
545	5327656	V Belt
546		Nut M10
547		Motor base unit weldment
548	5327099	2HP Electric Motor; D/I Models
548	5327429	3HP Electric Motor; D/I Models
548	5327429	3HP Electric Motor; D/I Models
549		Washer ϕ 10
550	5327318	Transmission Bracket Bushing
551	5400249	Rubber washer
552		Motor with support B
552		Motor with support Y
554	5327877	Rotary valve fixed set of device configuration diagram

Pedals

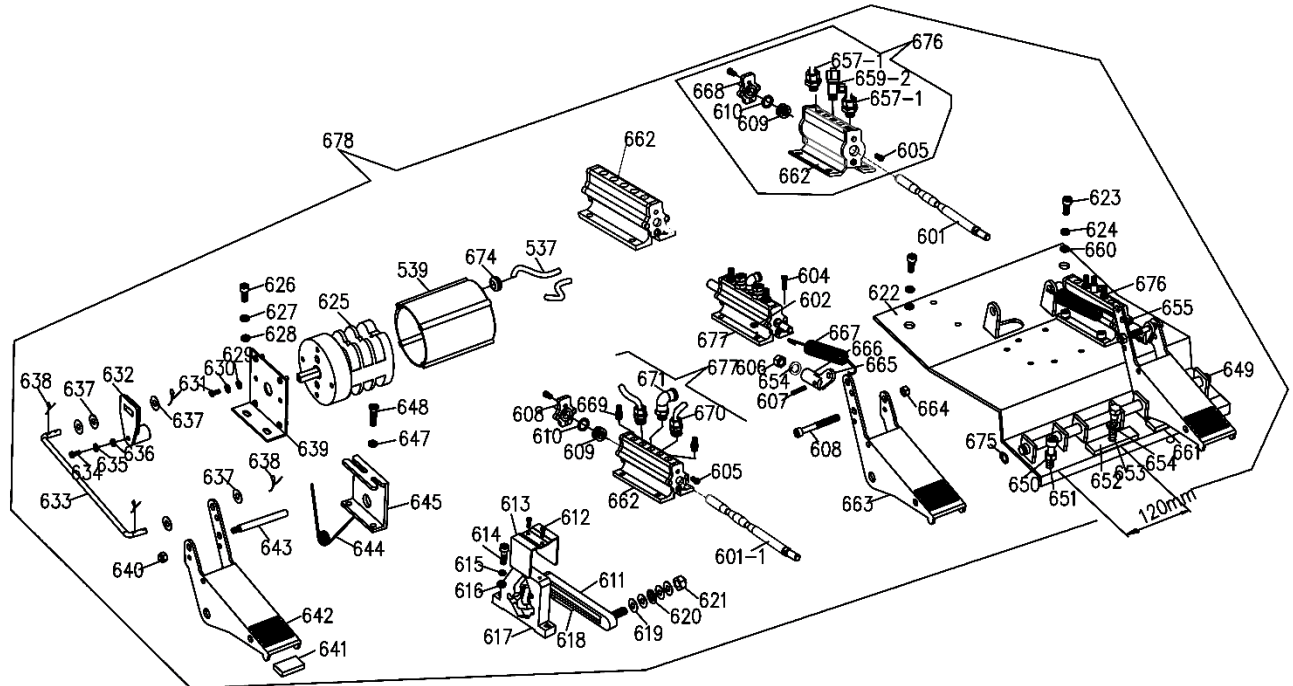

Number	Part Number	Description
539		Directional Switch Cover
601		Air valve shaft
601-1	5327531	Tilt tower air valve shaft I Models
602		Washer; $\phi 6$ spring
604		Cross recessed round head screw M6 x 12
605		Cross recessed round head screw M4 x 10
606		Nut M8
607		Spring pin M 4 x 18 $\phi 4$ x 18
608		Socket head cap screw M6 x 55
609	5327482	Air Valve O-Ring Spacer; I Models
610	5327536	O-Ring; 17 x 4; I Models
611	5327049	Foot Pedal Cam Link; I Models
612		Cross recessed tapping screws M3 x 10
613	5327412	Foot Pedal Cam Cover; I Models
614		Socket head cap screw M6 x 30
615		Washer; M6 x 12 mm Flat
616	5400913	Washer; M6 flat
617	5327047	Foot Pedal Cam; I Models
618		Cam Arc Washer
619		Washer $\phi 8$
620		Pad (waww)
621		Locknut M8
622		Foot pedal control board unit weldment
623		Socket head cap screw M8 x 20
624		Washer $\phi 8$
625	5400331	Turntable Direction Switch; B & I Models
626		Socket head cap screw M6 x 16

627		Washer; M6 x 12 mm Flat
628	5400913	Washer; M6 flat
629		Washer ϕ 5 flat
630		Washer ϕ 5 spring
631		Cross recessed round head screw M5 x 16
632	5400324	Turntable Direction Switch Cam; B & I
633	5327038	Directional Switch Cam Linkage; I Models
634		Cross recessed round head screw M4 x 16
635		Washer ϕ 4 spring
636		Washer ϕ 4 flat
637		Washer ϕ 6
638		Cotter pin ϕ 3.2 x 25
639		Directional Switch Bracket; I Models
640		Locknut M6
641		Foot Pedal Rubber Insert; I Models
642		Foot Pedal (Right); I Models
643		Foot Pedal Limit Rod; I Models
644	5327035	Foot Pedal Torsion Spring; I Models
645		Torsion Spring Bracket; I Models
647		Washer; M6 x 12 mm Flat
648		Cross recessed round head screw M6 x 12
649		Foot pedal shaft
650		Nut M8
651		Socket head cap screw M8 x 55
652		Control system adjustment pad (thin)
653		Hexagon headed bolt M8 x 16
654		Spring pad ϕ 8
655		Big cylinder locating coat
657-1		Fitting G1/4" ϕ 12 Straight
659-2		Tee joint union ϕ 10- ϕ 8-G1/4
660		Washer ϕ 8 flat
661		Control system adjust pad (thick)
662		Air Valve; I Models
662		Air Valve
663	5327033	Foot pedal (left)
664		Locknut M6
665	5327408	Air Valve Connecting Link; I Models
666	5327374	Foot Pedal Link; I Models
666		Foot Pedal Link; I Models
667	5327034	Foot Pedal Return Spring; I Models
668	5327499	Air Valve End Cap; I Models
669		Silencer G1/8"
669		Silencer G1/4
670		Fitting G1/8" ϕ 8
670		Silencer G1/4
671		Fitting 90° G1/4
671		Silencer G1/4"
674		Cable holder ϕ 12
675		Seeger ring ϕ 12

676		BB cylinder air valve assy
676		BB cylinder air valve assy
677		Cylinder air valve assy
678		Foot pedal assy

Turbo Blaster

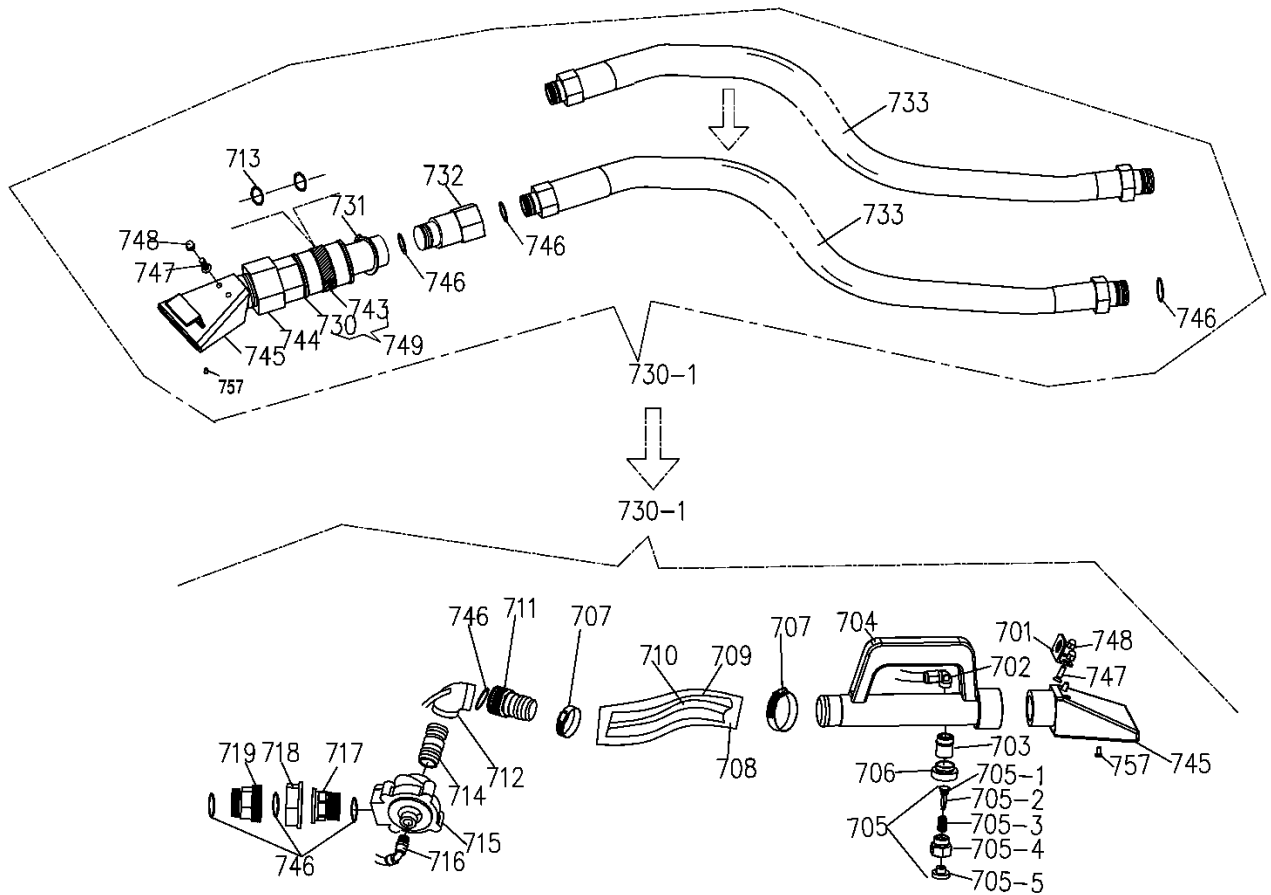

Number	Part Number	Description
702	5328443	Locknut elbow
703		Union
704		Turbo blast handle
705		Vent valve
706		Clamp nut
707		White steel buckle
708		Nylon sleeve
709		PVC steel wire tube
710		PU straight pipe
712		Elbow
713		O-ring $\phi 40 \times 3.55$
713	5327512	O-ring $\phi 40 \times 3.55$
714		Union
715	5328446	Turbo blast valve
716		Elbow
717		Movable joint

718		Movable joint sleeve
719		Movable joint
720	5328494	Outer wire pitch assembly
705-1		O-ring
705-2		Piston
705-3		Spring
705-4		Valve
705-5		Button
730		1" Connector
730		1" Connector
730-1	5327892	Turbo Blast Complete – OLD RED HOSE
730-1	5328444	Turbo Blast Complete – NEW CLEAR HOSE
731	5327611	Snap Ring ϕ 40
732	5327335	Turbo Blast Handle/Connector; I Models
733	5327603	Turbo Blast 1" Hose
733	5327603	Turbo Blast 1" Hose
733	5327603	Turbo Blast 1" Hose
743	5324125	Turbo Blast Valve; I Models, Xrev A
744	5327102	Turbo Blast Nozzle Adapter; I Models
745	5327044	Jet Blast Nozzle; I Models
701	5328445	Hook
745		Turbo blast nozzle cover
757		Cross recessed head tapping screw 4.2 x 13
747		Cross recessed round head screw M6 x 12
748		Acorn nut M6
746	5328442	O-ring ϕ 28 x 3.55
711		Turbo blast valve Joint
749		Turbo Blast Valve Assy; I Models
749		Turbo Blast Valve Assy; I Models

Assist Tower (not included with the R980XR)

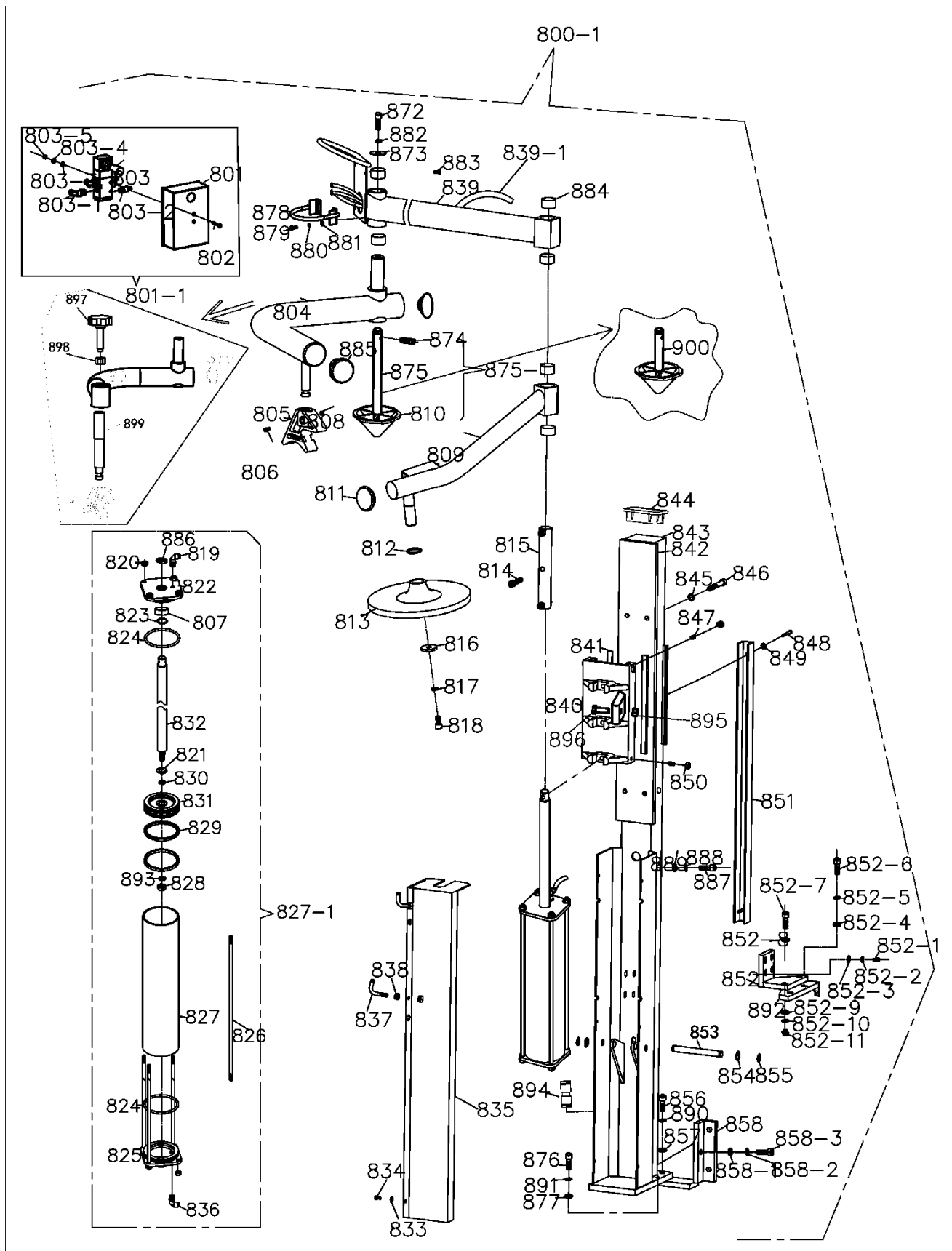

Number	Part Number	Description
800-1	5150545	Upgrade Tower
801-1		Assist Arm Valve Control Assy
801	5327098	L/R Assist Arm Valve Cover; I Models
802	5530012	Cross recessed round head screw M4 x 0.7 x 30 mm
803	5327109	Assist Arm Control Valve; I Models
803-1		Banjo bolt $\phi 6$ G1/8" Single
803-1		Banjo bolt $\phi 6$ G1/8" Single
803-2		Adjustment silencer G1/4"
803-3		Washer $\phi 4$ Flat
803-4		Washer $\phi 4$ Split lock
803-5		Nut M4
804	5327582	Assist Tower Bent Arm
805	5327075	Assist Arm Block
806	5400959	SHCS M6 x 30
807		
808		Nut M6
809	5327607	Left Assist Arm, Plastic Disk
810	5400890	Assist Arm Cone; B & I Models
811	5327433	Assist Arm End Plug
812		Seeger ring $\phi 25$
813	5400885	Plastic Disk; B & I Models
814		SHCS M10 x 50
815		Assist Arm Connecting Link
815		Assist Arm Connecting Link
816		Snap Ring
817		Washer $\phi 10$ Splick lock
818		SHCS M10 x 20
819		Locknut elbow
820		Nut M8
821		O-ring 16 x 2.4;
822		Cylinder front cover
823		O-ring $\phi 25$ x 2.65
824		O-ring $\phi 90$ x 2.65
825	5327429	Assist Tower Rear Cyl Plate
826		Cylinder connecting thread shaft
827		Left Assist Tower Cyl Bod
827-1	5327388	Left Assist Tower Cylinder
828		Locking Nut M12
829		O-ring $\phi 82.5$ x 5.3
830		O-ring $\phi 14$ x 2.4
830		O-ring
831		Assist Tower Cyl Piston;
831		Assist Tower Cyl Piston;
832		Left Assist Tower Cyl Rod
832		Left Assist Tower Cyl Rod
833		Washer $\phi 6$ Flat
834		SHCS M6 x 12
835		Left Assist Tower Cyl Cover

836		Locknut elbow
837	5327472	Turbo Blast Hook; I Models
838		Nut M8
839	5328299	Presser arm weldment
839-1		Metal Braided Hose Cover
840		Slide Unit
840		Slide Unit
841	5327483	Assist Tower Plastic Slide; I Models
841	5327483	Assist Tower Plastic Slide; I Models
842		Slide Guide
843		Left Assist Tower Weldment
844	5327434	Assist Tower Top Plug
845		Washer ϕ 10 Split lock
846		SHCS M10 \times 75
847		Inner hexangular set screw M8 x 16
848		SHCS M6 x 1.0 x 40 BOC
849		Washer ϕ 6
850		Nut M8
851		Assist Tower Air Hose Cover
852		Tower Bracket Weldment
852-1		SHCS M8 x 30
852-2		Washer ϕ 8 Flat
852-3		Snap ring ϕ 8
852-4		Washer ϕ 10 Flat
852-5		Washer ϕ 10 Split lock
852-6		SHCS M10X30
852-7		SHCS M10X45
852-8		Washer ϕ 10 Flat
852-9		Nut M8
852-10		Washer ϕ 10 Split lock
852-11		Washer ϕ 8 Flat
853	5327432	Assist Tower Lower Pin; R23/26 (I)
854		Washer ϕ 12 Flat
855		Snap ring ϕ 12
856		SHCS M10 \times 30
857		Washer ϕ 10 Flat
858		Lower supporter unit
858-1		Washer ϕ 10 Flat
858-2		Washer ϕ 10 Split lock
858-3		SHCS M10 x 30
872	5327580	SHCS M12 x 25
873		Washer
874		Roller latch M8X18
875	5400891	Cone Shaft; B & I Models
875-1	5400725	Assist Arm Cone Assy; B & I Models
876		SHCS M8 x 30
877		Washer ϕ 8 Flat
878		Assist arm handle weldment
879		Cross recessed pan head screw M5 x 12

880		Washer ϕ 5 Flat
881		Washer ϕ 5 Split lock
882		Washer ϕ 12 split lock
883		Cross recessed pan head screw M4 x 12
884		Bearing B3025
885	5327979	Assist tower bent arm plug
886		Seal ring ϕ 33 x 2.5 x 6
886		Seal ring ϕ 33 x 25 x 8
887		SHCS M8 x 30
888		Washer ϕ 8 Split lock
889		Washer ϕ 8 Flat
890		Washer ϕ 10 Split lock
891		Washer ϕ 8 Split lock
892		Chassis bracket weldment
893		Washer, ϕ 12 flat
894		Fitting; 8 mm to 6 mm reducer
895		Nut M10
896		HHB M10 x 35
897		To the top
898		Nut M18
899		Screw
900		Cone shaft; B & I model, short

Inflation Foot Pedal

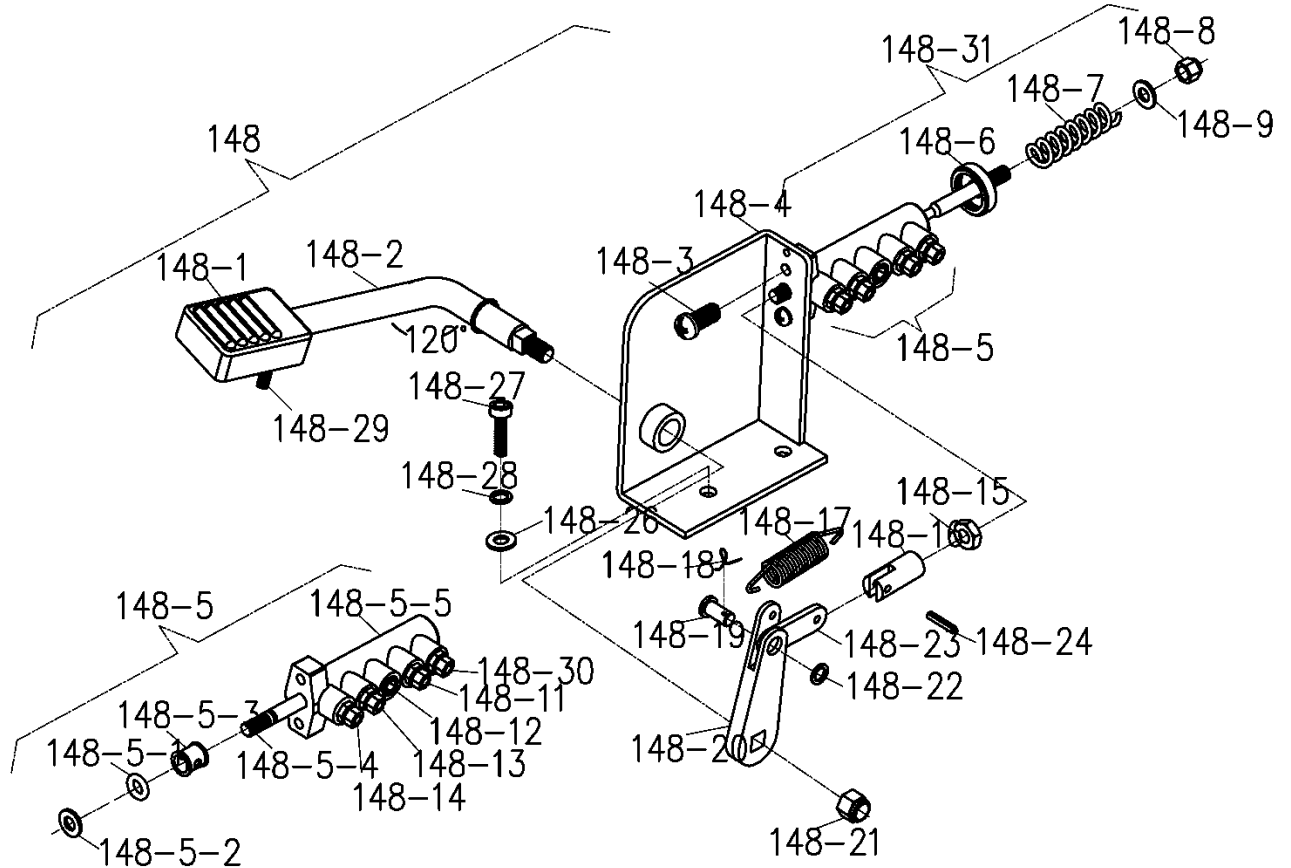

Number	Part Number	Description
148		Inflation foot pedal assy
148-1	5327178	Plastic foot pedal cover
148-2	5327670	Inflation foot pedal lever
148-3		Cross recessed round head screw M6 x 12
148-4		Pedal valve unit weldment
148-5		Bead blaster valve assembly
148-5-1	5327821	O-ring ϕ 15.4 x 3.9
148-5-2		Air valve end cap ϕ 15 x 1.2
148-5-3	5327820	Air valve O-ring spacer
148-5-4		Bead blaster valve lever
148-5-5	5327323	Air Valve Body
148-6		Air valve reinforce pad
148-7		Pressing spring
148-8		Locknut M8
148-9		Washer ϕ 8
148-11		Fitting, G 1/8" 8 mm
148-12		Block G 1/8"
148-13		Fitting, G 1/8" 8 mm
148-14		Fitting, G 1/4" 8 mm
148-15		Nut M8
148-16	5327374	Foot Pedal Link; I Models
148-17	5327669	Inflation Foot Pedal Spring
148-18		Cotter pin
148-19		Pin ϕ 8
148-20		Inflation foot pedal lever link
148-21	5400457	Nut M10 x 1.5 NL
148-22		Washer ϕ 8
148-23		Foot pedal
148-24		Open straight pin ϕ 4 x 18
148-26		Washer ϕ 8
148-27		Socket head cap screw M8 x 20
148-28		Washer ϕ 8
148-29		Inner hexangular set screw M6 x 10
148-30		Fitting, G 1/4" 8 mm
148-31	5327835	Inflation foot pedal valve

Assist Tower (Optional)

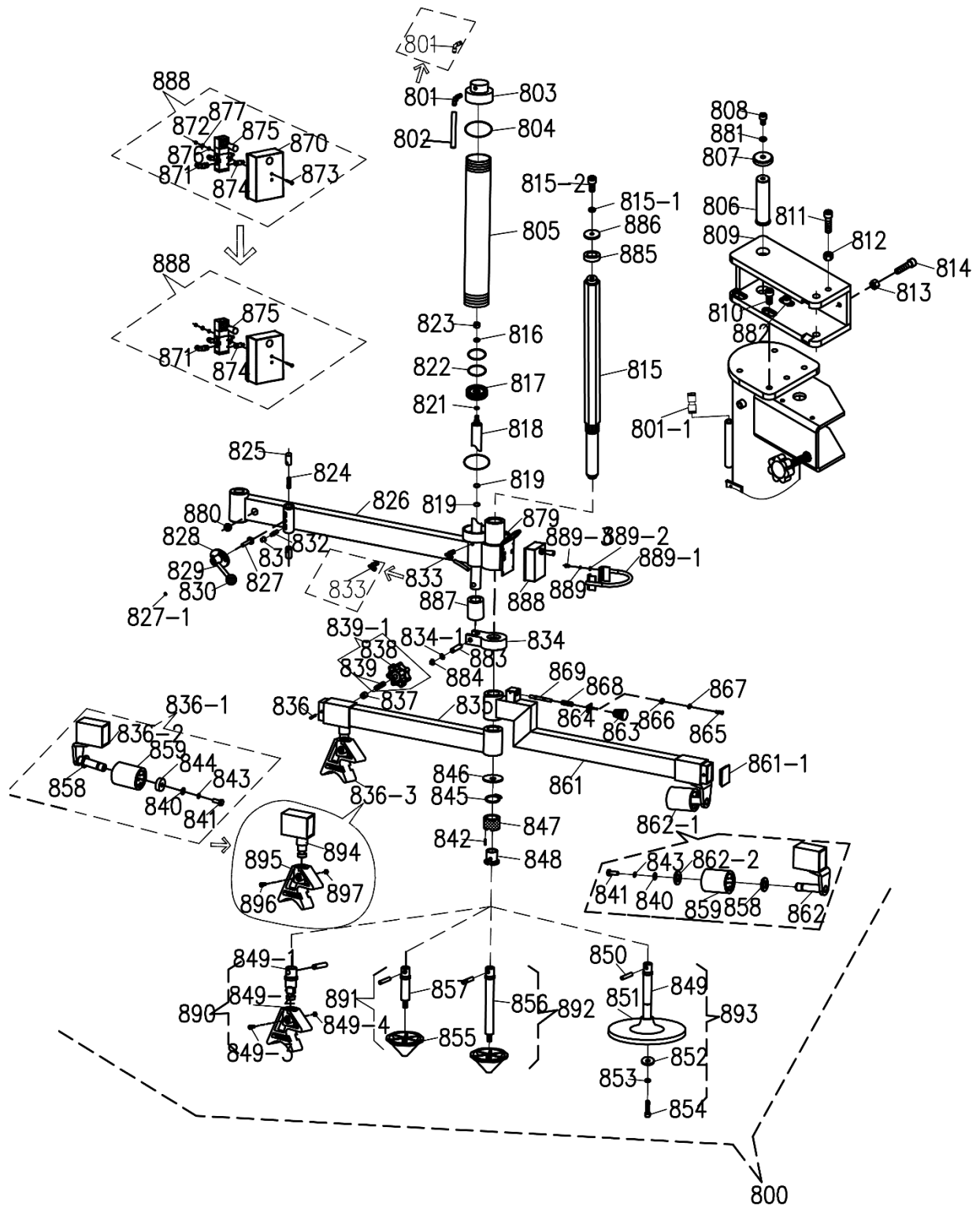

Number	Part Number	Description
800		Center power hand
801	5327740	Quick union M6X1/8" 90°
801		Fitting; $\Phi 6$ G1/8" 90°
801-1	5324168	8mm to 6mm union
802		PU air compressor hose $\phi 6$
803	5327637	Assist Tower Rear Cyl Plate; R30XLT(3)
804	5327638	O-Ring $\text{\O}84$ x 3.1mm; R30XLT (10)
805	5327639	Assist Cylinder Body $\text{\O}75$ x 360mm; R30XLT (4)
806		Big arm pin roll
807		Gland
808		Socket head cap screw M10X25
809		Big arm holder unit weldment
810		Socket head cap screw M12X25
811		Socket head cap screw M12X35
812		Nut M12
813		Nut M10
814		Socket head cap screw M10X35
815		Guide pin
815-1		Washer; $\text{\O}10$; Spring
815-2		Socket head cap screw M10X25
816	5327866	Washer M10 X 40
817	5327366	Small Cylinder Piston; I Models (4)
818	5327641	Assist Cylinder Rod $\text{\O}30$ x 533mm; R30XLT (4)
819	5327642	O-Ring $\text{\O}35$ x 3.1; R30XLT (10)
821	5327644	O-Ring $\text{\O}16$ x 2.4mm; R30XLT (10)
822	5327645	O-Ring $\text{\O}75$ x 5.7mm; R30XLT (10)
823	5400457	Nut; M10 X 1.5 NL
824	5327646	Assist Tower Lock Spring; R30XLT
825	5327647	Assist Tower Lock Pin; R30XLT
826	5328232	Assist Tower Main Arm R30/980 (I)
827	5327648	Assist Tower Lock Shaft; R30XLT
827-1		Snap ring $\text{\O}8$
828	5327649	Assist Tower Lock Cam; R30XLT
829	5327650	Assist Tower Lock Handle; R30XLT
830	5327651	Assist Tower Lock Knob; R30XLT
831	5327652	Assist Tower Lock Roller; R30XLT
832	5327653	Assist Tower Lock Link; R30XLT
833	5327740	Fitting; 1/8 X 6mm, 18mm
833		Fitting; $\text{\O}6$ - G1/8" 90°
834	5328109	AT Hex Shaft Connecting Plate; R30/980
834-1		Washer; $\text{\O}12$ flat
835	5328108	Lower small arm unit weldment
836		Cross recessed round head screw M6X12

836-1	5327802	Fixed roller assy. (A)
836-2		Assist arm slide roller weldment (A)
836-3		Slide set of components (C)
837	5327654	AT Roller Lock Nylon Insert; R30XLT
838		Club hand shank M12
839	5327857	AT ROLLER LOCK BOLT;R980/30
839-1	5327655	Assist Tower Roller Lock Knob; R30XLT (4)
840		Washer ϕ 10 flat
841	5327696	HHB M10X20(LEFT HAND THREAD)
842		Straight pin Φ 3X18
843	5402418	Washer; M10 X 16mm SL
844	5327697	Assist Tower Roller Lock Spacer; R30XLT
845		Seeger ring ϕ 35
846	5328081	Washer M35 x 49 Flat
847	5327657	Assist Tower Quick Chuck, Outer; R30XLT (4)
848	5327658	Assist Tower Quick Chuck, Inner; R30XLT (4)
849		Supporting plate bar
849-1	5327833	Drop center tool shaft
849-2	5327075	Assist Arm Block
849-3		Socket head cap screw M6X30
849-4		Nut M6
850		Straight pin Φ 10X38
851	5400885	Plastic Disk; B & I Models
852		Big arm pin roll clout
853		Washer ϕ 10 spring
854		Socket head cap screw M10X20
855	5400890	Assist Arm Cone; B & I Models
856	5327798	Long cone shaft
857	5327797	Short cone shaft
858	5327698	Washer; M22 X 31 Flat
858	5327698	Washer; M22 X 31 Flat
859	5327659	Assist Tower Roller; R30XLT
859	5327659	Assist Tower Roller; R30XLT
861	5328107	AT Free Roller Arm; R30/980
861-1	5328106	AT Arm End Plug; R30/980
862	5327660	Assist Tower Roller Slide; R30XLT
862-1	5327803	Free Assist Tower Roller
862-2		Roller pad
863	5327678	Roller Arm Lock Knob; R30XLT
864	5327661	Roller Arm Lock Knob Catch; R30XLT
865	5327825	BHPS M5 X 0.8 X 10
866		Washer ϕ 5; flat
867	5327826	Washer; 5M SL
868	5327662	Roller Arm Lock Knob Spring; R30XLT
869	5327663	Roller Arm Lock Knob Pin; R30XLT
870	5327098	L/R Assist Arm Valve Cover; I Models

871	5327740	Quick plug bent on $\phi 6$ -G1/4"
871		Banjo bolt 8mm 1/8 $\phi 6$ single
872		Washer $\phi 4$; flat
873		Cross recessed round head screw M4X30
874		Adjustment silencer G1/4"
874	5327545	Adjustment silencer G1/8"
875		Assist Arm Control Valve; I Models
875	5327109	Assist Arm Control Valve; I Models B
876		Cross recessed round head screw M4
877		Washer $\phi 4$
879		Cross recessed tapping screws M4.2X13
880		Cable holder $\phi 16$
881		Washer $\phi 10$ spring
882		Socket head cap screw M12X20
883	5328105	AT Cylinder pin' R30/980
884	5400905	Snap Ring; #12
885		Upper cushion pad
886		Upper cushion plate
887		Lower cushion pad
888		Assist arm control valve assy.
888		Assist arm control valve assy.
889		Washer; $\phi 5$; Spring
889-1		Assist arm handle weldment
889-2		Washer; $\phi 5$ flat
889-3		Cross recessed round head screw M5X12
890		Assist arm presser update kit
891		Wheel restraining cone assy. (A)
892		Wheel restraining cone assy. (B)
893		Plastic Disk; B & I Models
894		Assist Tower Roller Slide; R30XLT
895	5327075	Assist Arm Block
896	5400984	Nut M6
897	5400959	SHCS M6 X 1.0 X 30



1645 Lemonwood Drive
Santa Paula, CA 93060 USA