

Spray-Wash Cabinets

Installation and Operation Manual

Manual P/N 5900245 — Manual Revision C1 — July 2021

Models:

- RS-500-D-503
- RS-750-D-503
- RS-500-D-601
- RS-750-D-601
- RS-500-DS-601
- RS-750-DS-601



Powder-Coat model shown.

Designed and engineered by BendPak Inc. in Southern California, USA. Made in China.

 **DANGER**

Read the *entire contents* of this manual *before* using this product. Failure to follow the instructions and safety precautions in this manual can result in serious injury or death. Make sure all other operators also read this manual. Keep the manual near the product for future reference. *By proceeding with setup and operation, you agree that you fully understand the contents of this manual and assume full responsibility for product use.*****

Manual. RS-500-D-601, RS-750-D-601, RS-500-DS-601, RS-750-DS-601, RS-500-D-503, and RS-750-D-503 Spray-Wash Cabinets, *Installation and Operation Manual*, Manual P/N 5900245, Manual Revision C1, Released July 2021.

Copyright. Copyright © 2021 by BendPak Inc. All rights reserved. You may make copies of this document if you agree that: you will give full attribution to BendPak Inc., you will not make changes to the content, you do not gain any rights to this content, and you will not use the copies for commercial purposes.

Trademarks. BendPak, the BendPak logo, Ranger, and the Ranger logo are registered trademarks of BendPak Inc. All other company, product, and service names are used for identification only. All trademarks and registered trademarks mentioned in this manual are the property of their respective owners.

Limitations. Every effort has been made to use complete and accurate instructions in this manual. However, product updates, revisions, and/or changes may have occurred since this manual was published. BendPak Ranger reserves the right to change any information in this manual without incurring any obligation for equipment previously or subsequently sold. BendPak Ranger is not responsible for typographical errors in this manual. You can always find the latest version of the **manual for your product at the BendPak website**.

Warranty. The BendPak Ranger warranty is more than a commitment to you: it is also a commitment to the value of your new product. For full warranty details, contact your nearest BendPak Ranger dealer or visit bendpak.com/support/warranty. Go to bendpak.com/support/register-your-product/ and fill out the online form to register your product (be sure to click **Submit**).

Safety. Your new product was designed and manufactured with safety in mind. Your safety also depends on proper training and thoughtful operation. Do not set up, operate, maintain, or repair the unit without reading and understanding this manual and the labels on it; **do not use this product unless you can do so safely!**

Owner Responsibility. In order to maintain your product properly and to ensure operator safety, it is the responsibility of the product owner to read and follow these instructions:

- Follow all setup, operation, and maintenance instructions.
 - Make sure product setup conforms to all applicable local, state, and federal codes, rules, and regulations, such as state and federal OSHA regulations and electrical codes.
 - Read and follow all safety instructions. Keep them readily available for operators.
 - Make sure all operators are properly trained, know how to safely operate the unit, and are properly supervised.
 - Do not operate the product until you are certain that all parts are in place and operating correctly.
 - Carefully inspect the product on a regular basis and perform all maintenance as required.
 - Service and maintain the unit only with approved replacement parts.
 - Keep the manual with the product and make sure all labels are clean and visible.
- **Only use this product if it can be used safely!**

Unit Information. Enter the Model Number, Serial Number, and the Date of Manufacture from the label on your unit. This information is required for part or warranty issues.

Model: _____

Serial: _____

Date of Manufacture: _____

R Ranger		Santa Paula, CA USA www.rangerproducts.com	
MODEL NUMBER			
DESCRIPTION			
VOLTAGE			
DATE OF MFG.		SERIAL NUMBER	
DANGER! Disconnect Power Before Servicing		UPC	
CE EAC			
WARRANTY VOID IF DATA PLATE IS REMOVED PN 5905279			

Table of Contents

Introduction	3	Operation	12
Shipping Information	4	Maintenance	17
Safety Considerations	4	Troubleshooting	20
Specifications	6	Wiring Diagrams	22
Components	7	Labels	26
FAQ	9	Parts Diagrams	30
Setup	10	Maintenance Log	34

Introduction

This manual describes these Spray-Wash Cabinet models:

- **RS-500-D-601**: 1 Phase Spray-Wash Cabinet with 500 pound (227 kg) load capacity.
- **RS-750-D-601**: 1 Phase Spray-Wash Cabinet with 1,000 pound (454 kg) load capacity.
- **RS-500-D-503**: 3 Phase Spray-Wash Cabinet with 500 pound (227 kg) load capacity.
- **RS-750-D-503**: 3 Phase Spray-Wash Cabinet with 1,000 pound (454 kg) load capacity.

The RS-500-DS-601 and RS-750-DS-601 models are a Stainless Steel alternative to the Powder-Coat models; there are no differences in operation between the Powder-Coat models and Stainless Steel models.

More information about the full line of Ranger Products is available at rangerproducts.com.

 **WARNING** Always use a **certified, licensed Electrician** for electrical work. Wiring the unit incorrectly could result in human injury or product damage.

 **CAUTION** Only use Detergent formulated for mild steel parts washers; Aluma-Klean, for example, which is available from the [Ranger website](#). **Do not** use *high alkaline, high PH, caustic detergents that are formulated for harsher cleaning environments*; hot dip tanks, for example. This voids your warranty and may cause significant damage to your unit.

This manual is mandatory reading for all Spray-Wash Cabinet users, including anyone who sets them up, operates, maintains, or repairs them.

 **DANGER** Be very careful when setting up, operating, maintaining, or repairing this equipment; failure to do so could result in property damage, product damage, injury, or (in very rare cases) death. Make sure only authorized personnel operate this equipment. All repairs must be performed by an authorized technician. Make sure to read and follow the instructions on the labels on the unit.

Keep this manual on or near the equipment so that anyone who uses or services it can read it.

Technical support for your Spray-Wash Cabinet is available from your distributor or by calling **Ranger Products at (800) 253-2363**.

Shipping Information

Your equipment was carefully checked before shipping. Nevertheless, you should thoroughly inspect the shipment **before** you sign to acknowledge that you received it.

When you sign the bill of lading, it tells the carrier that the items on the invoice were received in good condition. **Do not sign the bill of lading until after you have inspected the shipment.** If any of the items listed on the bill of lading are missing or damaged, do not accept the shipment until the carrier makes a notation on the bill of lading that lists the missing or damaged goods.

If you discover missing or damaged goods **after** you receive the shipment and have signed the bill of lading, notify the carrier at once and request the carrier to make an inspection. If the carrier will not make an inspection, prepare a signed statement to the effect that you have notified the carrier (on a specific date) and that the carrier has failed to comply with your request.

It is difficult to collect for loss or damage after you have given the carrier a signed bill of lading. If this happens to you, file a claim with the carrier promptly. Support your claim with copies of the bill of lading, freight bill, invoice, and photographs, if available. Our willingness to assist in helping you process your claim does not make us responsible for collection of claims or replacement of lost or damaged materials.

Safety Considerations

Read this manual carefully before using your new product. Do not set up or operate the product until you are familiar with all operating instructions and warnings. Do not allow anyone else to operate the product until they are also familiar with all operating instructions and warnings.

 **WARNING** **California Proposition 65:** This product contains chemicals known to the State of California to cause cancer and birth defects or other reproductive harm. For more information, visit www.P65Warnings.ca.gov.

Safety Information

Please note the following:

- The product is a Spray-Wash Cabinet. **Use it only for its intended purpose.**
- The product should only be operated by authorized personnel. Keep children and untrained personnel away from the product.
- Do not open the Door while the unit is operating; always wait for the end of the Wash Cycle.
- When using the product, wear appropriate work clothes and ANSI-approved safety goggles. Do not wear loose clothing or jewelry. Keep hair and clothing away from the unit.
- When the product is in use, keep away from it.
- Do not use the product while tired or under the influence of drugs, alcohol, or medication.
- Do not use the product in the presence of cigarette smoke, dust, or flammable liquids or gases. Use the product indoors in a well-ventilated area.
- **Do not make any modifications to the product; this voids your warranty.**

-
- Make sure all operators read and understand the *Installation and Operation Manual*. Keep the manual near the device at all times.
 - Make a visual inspection of the product before using it. Do not use the product if you find any missing or damaged parts. Instead, take the unit out of service, then contact an authorized repair facility, your distributor, or Ranger Products at **(800) 253-2363**.
 - BendPak Ranger recommends making a **thorough** inspection of the product once a month. Replace any damaged or severely worn parts, decals, or warning labels.

Symbols

Following are the symbols used in this manual:



DANGER

Calls attention to a hazard that **will** result in death or injury.



WARNING

Calls attention to a hazard or unsafe practice that **could** result in death or injury.



CAUTION

Calls attention to a hazard or unsafe practice that could result in personal injury, product damage, or property damage.

NOTICE

Calls attention to a situation that, if not avoided, could result in product or property damage.

Liability Information

BendPak Ranger assumes **no** liability for damages resulting from:

- Use of the equipment for purposes other than those described in this manual.
- Modifications to the equipment without prior, written permission from BendPak Ranger.
- Injury or death caused by modifying, disabling, overriding, or removing safety features.
- Damage to the equipment from external influences.
- Incorrect operation of the equipment.

Specifications

Model	RS-500-D-601 and -503	RS-750-D-601 and -503
Outside Height	66" / 1,676 mm	78" / 1,981 mm
Inside Height	43" / 1,092 mm	54" / 1,372 mm
Inside width	32" / 813 mm	32" / 813 mm
Turntable diameter	30" / 762 mm	30" / 762 mm
Water reservoir	50 gallon (189.25 liter) capacity	53 gallon (200.5 liter) capacity
Load capacity	500 lbs. / 227 kg	1,000 lbs. / 454 kg
Wash Cycle Timer	1 to 60 minutes	1 to 60 minutes
Pump output	75 psi @ 70 gpm	70 psi @ 70 gpm
Motor, 1 Ph	208 – 240 VAC, 60 Hz	208 – 240 VAC, 60 Hz
Motor, 3 Ph	380 – 415 VAC, 50 Hz	380 – 415 VAC, 50 Hz
Heater	6 kW	6 kW
Water temp to start Wash Cycle	160° to 180°F (71° to 82°C)	160° to 180°F (71° to 82°C)

Components

Spray-Wash Cabinet components include:

- **Door.** Provides access to the inside of the unit; make sure it is shut and latched for a Wash Cycle.
- **Door Latch.** Keeps the Door firmly closed; make sure it is engaged before starting a Wash Cycle.
- **Breakers.** Control the Heaters. Three phase unit also has a main disconnect switch.
- **Handle.** Use the Handle on the right to open and close the Door. Use both Handles when moving the Spray-Wash Cabinet.
- **Parts Turntable.** Holds the Parts you are washing; turns during the Wash Cycle.
- **Parts Tree.** Connects to the Parts Turntable. Hang Parts on it that you want washed.
- **Parts Basket.** Holds smaller Parts; sits on the Parts Turntable.
- **Friction-Drive Wheel.** Turns the Parts Turntable. Powered by a motor on the back of the unit.
- **Water Reservoir.** Holds the Water/Detergent solution used to wash your car Parts. After a few Wash Cycles, the liquid in the Water Reservoir separates: Oil on top, Water/Detergent solution in the middle, and Sludge at the bottom.
- **Grate.** Covers the opening to the Water Reservoir. Water level should be just above the bottom of the Grate; if it is less than that, add more Water to bring it up to that level.
- **Wash Timer.** Controls the length of the Wash Cycle.
- **Wash Cycle.** The length of time the car Parts are washed, from 1 to 60 minutes. Generally, a 15-minute Wash Cycle is going to get off whatever is going to come off.
- **Spray Nozzles.** Spray Water onto the car Parts during a Wash Cycle.
- **Safety Switch.** Prevents a Wash Cycle from being started if the Door is open. When the Door is closed and latched shut, the Safety Stop holds down the Safety Switch; you can only start a Wash Cycle when the Safety Switch is being held down. *Do not use the Safety Switch as a way to stop a Wash Cycle before it is finished.*
- **Safety Stop.** The part of the Door that holds down the Safety Switch when the Door is latched closed. You cannot start a Wash Cycle unless the Safety Stop is holding down the Safety Switch.
- **Oil Skimmer.** Skims Oil from the top of the Water Reservoir.
- **Oil Skimmer Timer.** Controls the length of time the Oil Skimmer is on.
- **Oil Skimmer Sluice.** Controls where the Oil goes after the Oil Skimmer removes it from the Water Reservoir. Be sure to put a container under the Oil Skimmer Sluice to catch the Oil.
- **Casters.** Let you move the unit. Lock them when the unit is at the desired location.
- **Drain.** Drains Water and/or Sludge from the Water Reservoir. Found on the bottom of the unit on the left side.
- **Spillway.** Drains Water from the bottom of the Door back into the Water Reservoir after a Wash Cycle has finished.
- **Alarm.** If the Water level in the Water Reservoir gets too low, the red light goes on and the audible alarm comes on. Add Water before clearing the Alarm using the Reset Button.
- **Reset Button.** Clears the Alarm. Add Water to the correct level *before* clearing the Alarm.
- **Power Cord.** Connects the Spray-Wash Cabinet to a power source.
- **Electrical Panel.** Houses the wiring for the Spray-Wash Cabinet. The Alarm is on the side of the Electrical Panel, the Reset Button is on the top, the Breakers are on the back.

⚠ DANGER

Do not open the Electrical Panel unless directed to do so by Ranger Technical Support; there are no user-serviceable parts inside. **Only your Electrician should go into the Electrical Panel.**

The following drawing shows main components of the Spray-Wash Cabinet.

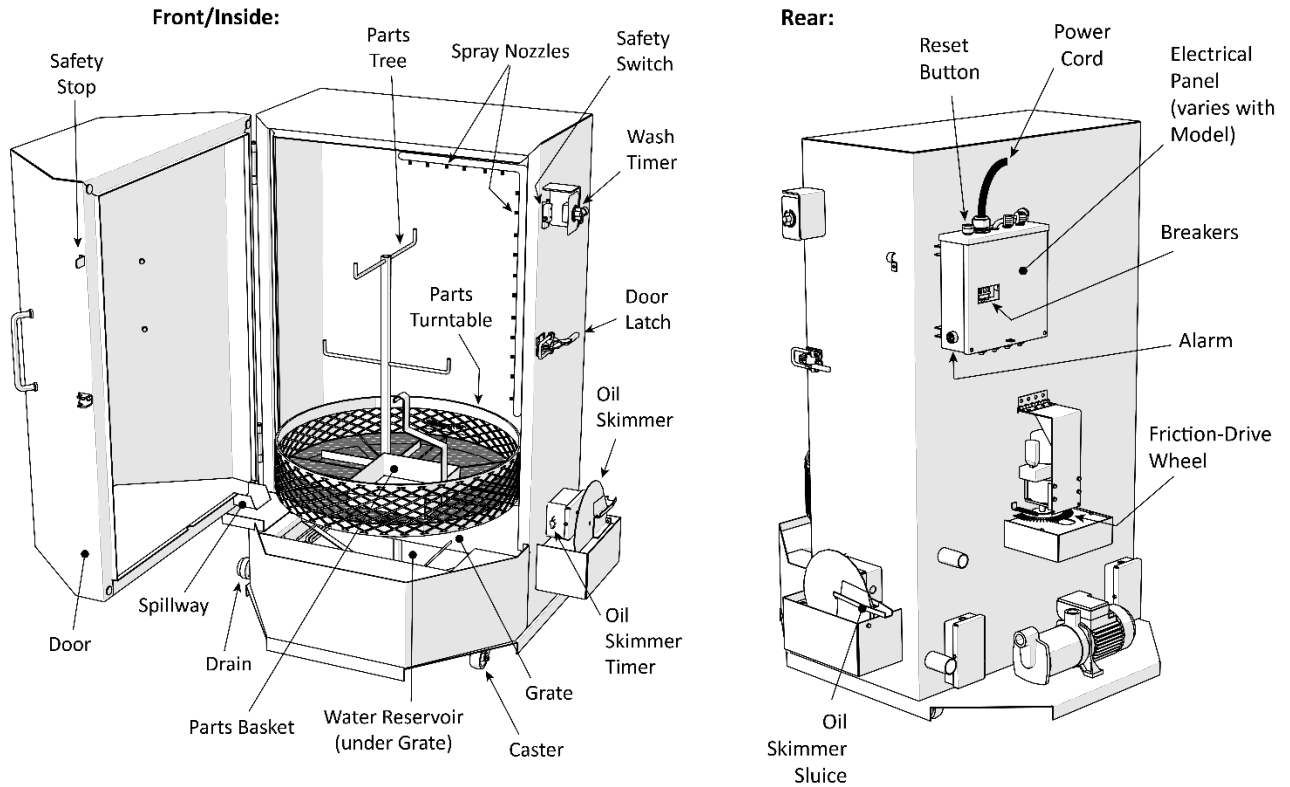

The following drawing shows the Circuit Breakers on the outside of the Electrical Panel.

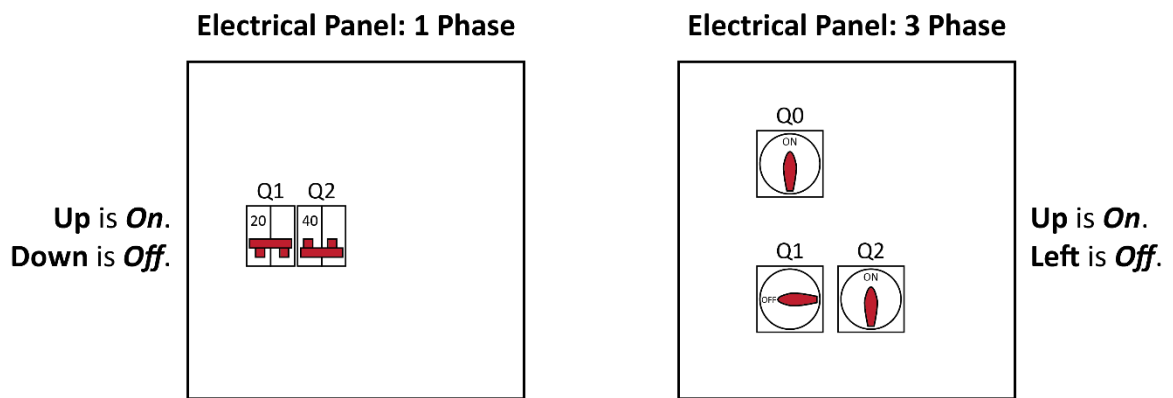

Drawing not to scale. Not all components shown. Consider locking Electrical Panel.

Frequently Asked Questions

Question: What does a Spray-Wash Cabinet do?

Answer: It cleans Vehicle parts, removing contaminants like Oil, grease, dirt, and so on. It uses a Water/Detergent solution, which cleans using a combination of mechanical force, heat (160° to 180°F / 71° to 82°C), and the chemical action of the Detergent.

Q: How many car Parts can I wash at one time?

A: The RS-500 models can hold up to 500 pounds (227 kg) of Parts at a time. The RS-750 models can hold up to 1,000 pounds (454 kg).

Q: What kind of Detergent should I use?

A: BendPak Ranger recommends using Aluma-Klean Detergent; in fact, you get a free bucket with your Spray-Wash Cabinet. **To re-order Aluma-Klean, visit the Ranger website.**

Be careful handling Aluma-Klean when in liquid form; wear gloves and eye protection. Do not ingest; try not to inhale.

If you decide to order any other kind of Detergent for your Spray-Wash Cabinet, it is extremely important that you **get the right kind**. Any Detergent you use must be formulated for mild steel parts washers; it must have rust-inhibiting agents and be low foaming.

⚠ CAUTION **Do not** use high alkaline, high pH, caustic detergents that are formulated for harsher cleaning environments; hot dip tanks, for example. This voids your warranty and may cause significant damage to your unit.

Q: How much Water do I need?

A: The RS-500-D models need about 50 gallons (189 liters) to be full. The RS-750-D models need about 53 gallons (200 liters). Always make sure the Spray-Wash Cabinet has enough Water; **the top of the Water line should be just above the bottom of the Grate**. You can damage your unit if you run it without enough Water in the Water Reservoir.

Q: How long is a Wash Cycle?

A: Anywhere from 1 to 60 minutes. In most cases, a 15-minute Wash Cycle does the job, but you can set it for as long as 60 minutes.

Q: How does a Wash Cycle work?

A: Put your Parts inside, latch the door, and then set the Timer for 1 to 60 minutes; the Spray-Wash Cabinet does the rest. Make sure the door is securely latched; you do not want the Door opening during the Wash Cycle.

Q: Is there a Start-Up Process before I can start cleaning?

A: Yes, but it's not difficult and usually only needs to be done once. You fill the Reservoir with Water, heat it up appropriately, put in Detergent, run a Wash Cycle (with no dirty Parts) for 15 minutes, and then run a Wash Cycle for 60 minutes (again, no parts) to coat the inside of the unit with the rust-inhibiting agents in the Detergent.

Q: Why is there a **Danger HOT Surface** sticker on the front of the Spray-Wash Cabinet?

A: Because the Door and rest of the Cabinet get hot during a Wash Cycle. Do not touch the Door or the rest of the Cabinet during or right after a Wash Cycle; you could get burned.

Setup

This section describes how to get your Spray-Wash Cabinet up and running.

Note: Most of the setup procedure is the same for both models; exceptions will be noted in the text where appropriate.

Unpacking

Use caution when unpacking the Spray-Wash Cabinet from its shipping container. You do not want to damage the unit or misplace any of the components that come with it.



Tip Unpack the components in the area where you are going to use the unit.

Location

There are some aspects of the product to keep in mind when deciding on a location:

- The Spray-Wash Cabinet generates steam. Make sure this steam will have no adverse effects on things in the surrounding area.
- Consider using traction/drainage mats around the Unit; removing the clean but wet Parts from the Spray-Wash Cabinet frequently results in Water and solution spilling onto the floor. Do not place the unit on or near a walkway, as this increases the chances of someone slipping.
- Allow room around the Spray-Wash Cabinet for service and other activities. Make sure the site is level; you do not want the unit rolling.
- You will be adding Water to the Water Reservoir on a regular basis, so make sure the location you choose has access to a Water supply.

Power Source

The Spray-Wash Cabinet does not come with a connector on the end of the Power Cord; it is your responsibility to supply the connector and have an Electrician attach it to the Power Cord.

Refer to [Wiring Diagrams](#) for wiring information.

⚠ WARNING All electrical work, such as attaching the connector to the Power Cord, ***must be done by a licensed, certified Electrician.***

Your Electrician needs to:

- Attach a connector to the end of the Power Cord, so that it can be connected to the power source.
- Install a breaker / disconnect box for the 1 Phase unit.
- Ensure that all local and national codes are adhered to. Use only with GFCI protected receptacles.

Connecting the Drain

The unit has a two-inch-wide Drain on one side that can be used to drain the Water Reservoir. You will need to capture what comes out, as it is illegal to dump it into the sewage system. Refer to [Maintenance](#) for more information.

Usage Precautions

Keep the following in mind as you prepare to use your Spray-Wash Cabinet:

- Read the entire *Installation and Operation Manual* **before** using the unit.
- Make a visual inspection of the unit before each use. Do not operate your Spray-Wash Cabinet if you find any issues. Instead, take the unit out of service, then contact your dealer, visit www.bendpak.com/support/, or call Ranger Products at **(800) 253-2363**.
- The heating elements and pump/motor can be damaged if the Water level drops too low; **always make sure the Water Reservoir is full of Water.**

Check the Water level daily; it should be **just above the bottom of the Grate**. Do not allow the Water level to go below the bottom of the Grate. Keep the Grate clean so the Water can return to the Water Reservoir after a Wash Cycle.

- Clean the unit according to the instructions in **Maintenance**. Your Wash Cycles will not clean effectively if the Spray-Wash Cabinet is dirty.
- Your Spray-Wash Cabinet is made with mild steel; it may rust unless you use the correct Detergent (with the right concentration) and **perform the Start-Up Process correctly.**

Important Make sure the Detergent you are using is safe on mild steel and has rust inhibitors, such as Aluma-Klean Detergent, which is available on [the Ranger website](#).

Important Ranger Products does **not** warranty their product against rust. Rust will occur if the wrong detergent is used, if the start-up procedure is not followed, or if the machine is not used on a regular basis (should oil build up on the inside). Rust can occur if you use deionized water for rinsing.

- When performing the Start-Up Process, do not start it unless you have the time needed to heat the Water to 140° to 160°F, add the Detergent to the Water Reservoir, run a 15-minute Wash Cycle (to mix the Detergent into the Water) and then run a 60-minute Wash Cycle (to coat the steel on the inside of the unit with rust inhibitor).
- The Door and the rest of the Cabinet get hot during a Wash Cycle.

 **WARNING** Do not touch the Door or any part of the Cabinet during or right after a Wash Cycle; you could be burned.

Water Temperature

It is important to keep the temperature of the Water in the Spray-Wash Cabinet in the range of 160° to 180°F (71° to 82°C).

When the unit is plugged in to a power source and the Breakers are On, the Spray-Wash Cabinet's thermostat keeps the Water in the 160° to 180°F range automatically.

When the unit is unplugged from a power source or the Breakers are set Off, the Spray-Wash Cabinet's thermostat goes off and the Water's temperature returns to room temperature.

Because it is important that you not start a Wash Cycle until the Water temperature is in the range of 160° to 180°F (71° to 82°C), BendPak Ranger recommends using a portable industrial thermometer to check the temperature of the Water as needed.

Friction-Drive Wheel

The Friction-Drive Wheel is on the inside back of the Spray-Wash Cabinet; it meshes with the Parts Turntable on the inside of the cabinet. When you run a Wash Cycle, the Friction-Drive Wheel turns, which in turn moves the Parts Turntable.

To remove the Parts Turntable, you must first pull back the Friction-Drive Wheel (from the rear of the Spray-Wash Cabinet).

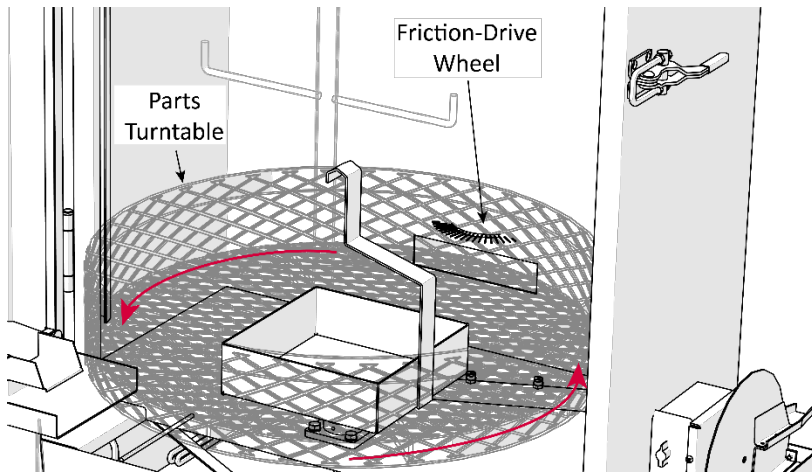

Operation

When your Spray-Wash Cabinet is ready, ***you must perform the Start-Up Process first.*** This is crucial, as significant problems can happen later unless you break it in correctly now.

After performing the Start-Up Process, you can use the unit normally.

⚠ CAUTION Do not touch the Door or the rest of the Cabinet during or immediately after a Wash Cycle; you could get burned.

About Detergent

Ranger recommends using Aluma-Klean Detergent; in fact, you get a bucket of this Detergent with your Spray-Wash Cabinet. To order more Aluma-Klean Detergent, [visit the Ranger website](#).

If you decide to order any other kind of Detergent for your Spray-Wash Cabinet, it is extremely important that you get the right kind. Any Detergent you use ***must*** be formulated for mild steel parts washers; it must have rust-inhibiting agents (to prevent rust) and be low foaming (to prevent foaming).

⚠ CAUTION **Do not use** high alkaline, high PH, caustic Detergents that are formulated for harsher cleaning environments; hot dip tanks, for example. ***If you use high alkaline, high PH, caustic Detergents in your Spray-Wash Cabinet, you void your warranty*** and may cause severe damage to your unit.

The Material Data Safety Sheet for the Aluma-Klean Detergent is available on [the Ranger website](#) (<http://www.bendpak.com/shop-equipment/parts-washer/soap-50-lbs.aspx>).

Be careful handling Aluma-Klean when in liquid form; wear gloves and eye protection. Do not ingest; try not to inhale. Refer to [Additional Aluma-Klean Safety Information](#) for additional safety information.

Start-Up Process

The Start-Up Process prepares your Spray-Wash Cabinet for normal use; it is **required**.

The Spray-Wash Cabinet must be empty for the Start-Up Process. Do not begin the Start-Up Process unless you have the approximate two hours necessary to complete it.

⚠ CAUTION Proper eye and glove protection is **required** when handling the Detergent. Consult medical attention immediately if the Detergent gets into the eyes or if ingested.

To perform the Start-Up Process:

1. Make sure the Breakers are Off **and** the Power Cord is disconnected from power.
2. Open the Door and remove anything that should not be in there when you run a normal Wash Cycle.
3. Fill the Water Reservoir so that the Water level reaches just above the bottom of the Grate.
For the RS-500-D models, this is 50 gallons (189 liters); for the RS-750-D models, this is 53 gallons (200 liters).

4. Connect the Power Cord to the power source, then set the Breakers to On.

5. Make sure the Safety Switch prevents the Spray Nozzles from working when the Door is open.

To do this: open the Door, stand back, and start a Wash Cycle. If the Spray Nozzles start working, do **not** use the unit; instead, take it out of service and refer to the **Troubleshooting** section. If the Spray Nozzles do not start working, then continue to the next step.

6. Determine how much Detergent you will need for your unit.

The following table compares the Detergent concentration to use with your Spray-Wash Cabinet.

Detergent Use	Pros	Cons
High Concentration: <i>approximately 1/2 lb per gallon</i>	<ul style="list-style-type: none">• Superior cleaning• Little chance of rusting	<ul style="list-style-type: none">• Possible leftover residue inside Cabinet• Possible clogged nozzles
Low Concentration: <i>approximately 1/4 lb per gallon</i>	<ul style="list-style-type: none">• Little or no residue• Less use of Detergent	<ul style="list-style-type: none">• Possible rusting inside Cabinet• Parts not clean enough

NOTICE Your unit is shipped with 20 lbs. of Aluma-Klean, which is typically enough to run the Spray-Wash Cabinet in most applications. This strikes a balance between using too much Detergent (which can result in leftover residue inside the Cabinet) and using too little (which increases the chances of rusting inside the Cabinet). If you use any other kind of Detergent, follow the Detergent manufacturer's recommendations for how much Detergent to use.

7. When the Water temperature reaches 160°F (measure it using a thermometer), carefully pour approximately half of the required amount of Detergent into the Water Reservoir, *wait about a minute*, and then add the other half.

Do not add all of the Detergent to the Reservoir at the same time.

⚠ CAUTION The Water Reservoir **must** be properly heated before adding the Detergent.

8. Close and latch the Door, then run a 15-minute Wash Cycle.

This dissolves the Detergent into the Water.

Do not put any dirty Parts in the Spray-Wash Cabinet for this cycle.

If there is severe Water leakage, refer to **Troubleshooting** for assistance.

9. Run a second Wash Cycle, this time for 60 minutes.

This coats the inside of the Cabinet with the rust-inhibiting agents in the Detergent.

Do not put any dirty Parts in the Spray-Wash Cabinet for this cycle.

10. When the second Wash Cycle is complete, the Spray-Wash Cabinet is ready for normal operation.

Normal Operation

Normal operation for the Spray-Wash Cabinet is either running a Wash Cycle or using the Oil Skimmer.

⚠ CAUTION Do not touch the Door or any other part of the Cabinet during or right after a Wash Cycle; you could get burned.

⚠ CAUTION Proper eye and glove protection **must** be worn when loading and unloading parts to be cleaned.

To run a normal Wash Cycle:

1. Make a visual inspection of the unit. If there are any issues, refer to **Troubleshooting**.
2. Make sure the Breakers are On and the Power Cord is connected to a power source.
3. Check the temperature of the Water/Detergent solution using a thermometer; it **must** be in the range of 160° to 180°F (71° to 82°C) to start a Wash Cycle.

If the Water temperature is below 160°F, you **must** wait for it to heat it up.

4. Clean as much excess dirt and grease as you can from the Parts you are going to clean.
5. Open the Door of the unit and put in the Parts you want to clean.
6. Close the Door, make sure the Door Latch is latched, and set the Timer for 1 to 60 minutes.

⚠ CAUTION Do not open the Door while a Wash Cycle is in progress.

7. When the Wash Cycle is over, wait a minute, then remove the now-clean Parts.

Note: If the Door opens too widely, some Water/Detergent solution can miss the Spillway and fall onto the floor. To fix this, shorten the Chain so the Door does not open so wide.

8. If you are not going to run additional Wash Cycles, you can set the Breakers to Off.

Note that the Water temperature will start moving down towards room temperature if you do, so you will need to warm it back up before you can perform your next Wash Cycle.

If you prefer, you can keep the Breakers On, which keeps the water temperature in the 160° to 180°F (71° to 82°C) range needed to perform a Wash Cycle.

Using the Oil Skimmer

When the Oil on the top of the Water Reservoir is ¼ inch (6 mm) or deeper, use the Oil Skimmer to remove it. Too much Oil in the Water Reservoir impacts operation of the Spray-Wash Cabinet.

⚠ CAUTION Proper eye and glove protection is **required** when working with Oils.

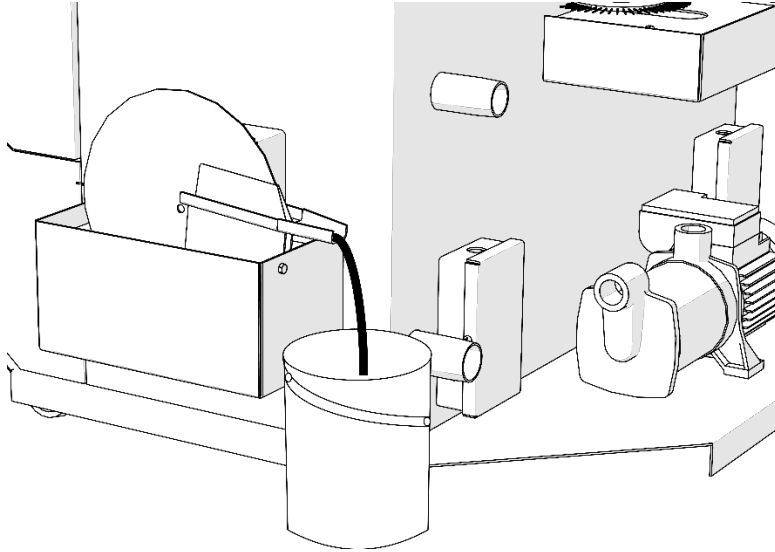

To use the Oil Skimmer:

1. Put a container under the Sluice end of the Oil Skimmer.
2. Turn on the Oil Skimmer Timer.
3. Watch the Oil Skimmer to make sure the Oil Skimmer is turning and that it is removing Oil from the top of the Water Reservoir.
4. If the Oil Skimmer does not turn or does not remove Oil, refer to **Troubleshooting**.
5. When the skimming session is over, keep the container in place until all of the Oil has fallen into it.
6. Dispose of the Oil per applicable federal, state, and/or local codes; refer to **Environmental Issues** for more information.

Low Water Shut-Off Switch

The Low Water Shut-Off Switch shuts off the system if the wash solution in the Water Reservoir drops below a safe level. If the wash solution drops below the lower proximity of the switch, the low water indicator light on the control panel turns on and the system disconnects power.

To reset the system, add water to the Water Reservoir until the Low Water indicator light turns off.

⚠ CAUTION The correct water level in the Reservoir is just below the grate. Do **not** allow the water level to drop below the pump inlet or heating elements, you will damage the unit.

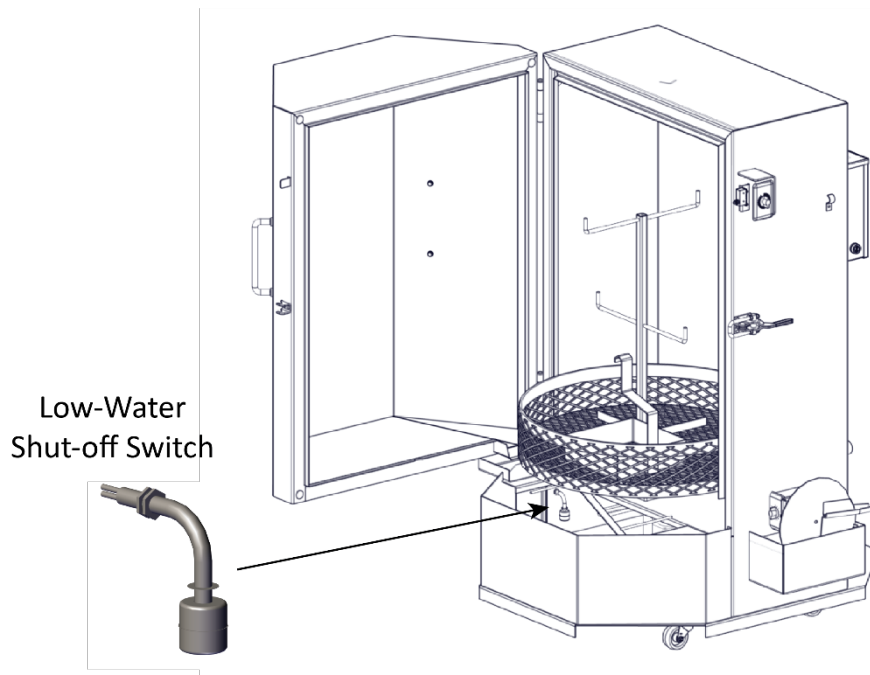

Note: The Low Water Shut-Off Switch should move up and down smoothly without hanging up or operating erratically.

⚠ WARNING To prevent electrical shock, always fully disconnect from the power source before performing any maintenance to the Machine.

Important Water Level Warnings

Please note the following:

- Check the water level **daily**, when adding water, be careful to not overfill the Reservoir.
- Remove any excess water with a small, submersible pump or an appropriate container.
- Sludge build-up in the Reservoir will cause the Low Water Shut-Off Switch to malfunction.
- Inspect and clean the Low Water Shut-Off Switch weekly during heavy use to prevent sludge buildup.
- **Do not use the Spray Wash Cabinet if the Reservoir Pump is sucking air**, you could seriously damage the unit.

Maintenance

Make sure your Spray-Wash Cabinet is maintained on a regular basis.

If you do not use the unit for an extended period of time, coat the inside of the Cabinet with rust dissolver (such as WD-40®) to reduce rust formation.

Regular Maintenance

 **WARNING** The unit uses electrical energy; set the Breakers to Off and disconnect the Power Cord from power **before performing any maintenance!** If your organization has Lockout/Tagout policies, make sure to implement them after connecting to a power source.

To maintain your Spray-Wash Cabinet:

- **Daily:** Check the Water Reservoir level; it should be just above the bottom of the Grate. Do not start a Wash Cycle if the Water level is below the bottom of the Grate.
- **Daily:** Wipe up any cleaning solution that has spilled.
- **Daily:** Skim the floating Oil out of the Water Reservoir when it is at or over 1/4 inch (6 mm) deep or the Oil starts to impede cleaning.
- **Monthly:** Inspect and clean the Low Water Shut-Off Switch to ensure proper operation; keep the Low Water Shut-Off Switch clean and free of sediment build-up.
- **Monthly:** Check all external hoses for leaks or weaknesses and replace if necessary. Check hoses during a Wash Cycle to see if a bubble forms in the hose lining.
- **Monthly:** Check all components to make sure they are in good operating condition. If you find a component that is not working correctly, take the unit out of service and refer to **Troubleshooting** for more information.
- **Monthly:** Remove Sludge from the Water Reservoir, as described in **Removing Sludge**. Clean out the Water Reservoir every week for the first month, then develop an appropriate schedule based on what you are cleaning and how often.

Do not allow the Sludge in the Water Reservoir to exceed one inch in depth. If you do, the Sludge buildup could damage other components.

- **Every three months:** Inspect the Friction-Drive Wheel for worn wire brushes; replace any that are worn (Ranger SKU 5335721).
- **Every three months:** Lubricate the grease fitting under the Parts Turntable with white lithium grease or similar; make sure to replace the cap.
- **Yearly:** Have your electrician come out and check the electronic components.
- **Yearly:** Take the unit out of service (Breakers set to Off, Power Cord unplugged from power) and thoroughly check and clean all components.

 **WARNING** Do not operate your Spray-Wash Cabinet if you find issues; instead, take the unit out of service, then contact your dealer, visit rangerproducts.com/support/, or call **(805) 933-9970**.

Removing Sludge

You need to clean out the Sludge from the Water Reservoir on a regular basis so that it does not damage other Spray-Wash Cabinet components or reduce cleaning.

⚠ CAUTION *Do not allow the Sludge to exceed one inch deep*; it could damage other Spray-Wash Cabinet components.

The amount of Sludge you will see is based on what Parts you clean and how often you clean them. When you first get your Spray-Wash Cabinet, remove the Sludge every week. After the first month, develop an appropriate schedule based on what you are cleaning and how often. Remember to ***never let the Sludge exceed one inch deep.***

⚠ DANGER Set the Breakers to Off and disconnect the Power Cord from power before beginning this procedure or any other maintenance.

To remove Sludge from the Water Reservoir:

1. Remove the Parts Tree, Parts Basket, Parts Turntable, and the Grate covering the Water Reservoir.
2. Open the Drain, remove the Water above the Sludge, then close the Drain.

You can also use a small submersible pump to remove the wash solution.

You can reuse this Water if it is clean. If it is dirty, dispose of it properly.

3. Scrape out the Sludge through the Grate covering the Water Reservoir; be careful not to hit the heating elements inside the Water Reservoir.

Opening the Drain may help you remove the Sludge; be sure to catch any Sludge that comes out.

4. Put the Sludge in a container and store it as hazardous waste.

Make sure to dispose of the Sludge properly. See [Environmental Issues](#) for more information.

5. Replace the Water content, correct the Water level, and replace the Grate covering the Water Reservoir, the Parts Turntable, the Parts Basket, and the Parts Tree.
6. Heat the wash water to operating temperature.
7. Add the appropriate amount of detergent and run the machine through a 30-minute cycle.

Cleaning Spray Nozzles

If the Water/Detergent solution in the Water Reservoir is very dirty, your Spray Nozzles could get clogged from the inside.

To deal with clogged Spray Nozzles:

- Increase the frequency you use the Oil Skimmer and remove Sludge.
- Replace all of the Water in the Water Reservoir, then run a 60-minute Wash Cycle with no Parts.
- If your Spray Nozzles are clogged, you may need to flush the Spray Pipes. Remove any Pipe Caps and bottom Spray Nozzles and run a brief 30 – 60 second wash cycle to flush out the sediment.
- Remove the clogged Spray Nozzles with a wrench, clean them, then put them back in.

⚠ WARNING Do not run a Wash Cycle without the Spray Nozzles in place; you could damage the Pump Motor.

Environmental Issues

Do not dispose of your Spray-Wash Cabinet waste by throwing it in the trash; it is not regular waste.

Important: You must dispose of the liquid waste that comes from your Spray-Wash Cabinet per all applicable federal, state, and/or local codes. Failure to dispose properly harms the environment and exposes your business to fines and/or legal issues.

Note that appropriate disposal methods include safely storing your waste until you are ready to dispose of it.

You must be proactive and determine the best legal and ethical ways to dispose of this waste.

Your Spray-Wash Cabinet produces three types of liquid waste that must be disposed of properly:

- **Oil.** Sits on top of the Water/Detergent mixture when washed off of car Parts. After you remove it using the Oil Skimmer, you must dispose of it properly.
- **Water/Detergent mixture.** Used to clean your car Parts. The resulting liquid is not safe to dispose of using normal methods; you must dispose of it properly.
- **Sludge.** Sinks to the bottom of the Water Reservoir. This semi-liquid waste is a combination of the wastes that came off of the car Parts that you cleaned. It also must be disposed of properly.

Some ideas for finding the legal and ethical ways of disposing of the waste from your Spray-Wash Cabinet include:

- Contact the Environmental Protection Agency (their website is [epa.gov](https://www.epa.gov)) to see if they provide any advice about how to dispose of liquid waste.
- Use a home pickup service, if your waste management company offers it in your area for your liquid waste. Contact your waste management company for more information.
- Find a drop-off facility that accepts your liquid waste. Contact your state and/or local government for more information about these facilities.
- Hire a waste management consultant. They can come to your business location, review your waste, and give you their opinion of how best to dispose of it.

Troubleshooting

Issue	Action to Take
Pump and heaters not working.	Make sure the Spray-Wash Cabinet is getting power. Check the Breakers; make sure they are On.
Cleaning quality is poor.	Make sure the right Detergent is being used. Make sure the Spray Nozzles are not clogged. Make sure the Water/Detergent solution is not dirty but is hot.
Water/Detergent solution does not get hot.	Make sure the Spray-Wash Cabinet is getting power (Breakers on, Power Cord connected), then wait for the temperature to rise to 160° to 180°F (71° to 82°C).
Pump motor comes on but is not pumping or has little pressure.	Make sure Water level is high enough; it should be just above the bottom of the Grate. Make sure the Spray Nozzles and/or pump impeller are not clogged from the inside; if they are, clean them.
Spray Nozzles and/or pump impeller clog frequently.	Use the Oil Skimmer and remove Sludge more often. Clean or replace the Water/Detergent solution more often. Remove the Spray Nozzles and/or pump impeller, and clean them.
Solution is foaming.	You are using the wrong Detergent; switch Detergents. The Wash Cycle was started when the Water/Detergent solution was cold; <i>you must warm the solution to at least 160°F (71°C) before starting a Wash Cycle.</i> Detergent concentration is too low; add Detergent. Water level is too low; add Water.
Rust inside cabinet.	You are using the wrong Detergent; switch Detergents. Detergent concentration is too low; add more Detergent. The Spray-Wash Cabinet is not being used enough; remove the rust, then perform a Wash Cycle at least once a month. Spray-Wash Cabinet was not started up correctly. Remove rust with steel wool, change solution to twice the normal Detergent level, then perform the Start-Up Process again.
Turntable not turning smoothly.	Check the Friction-Drive Wheel for worn wire brushes. If worn, replace with Ranger SKU 5335721.

If you continue to have problems with your Spray-Wash Cabinet, visit www.bendpak.com/support/ or call **Ranger Products at (805) 933-9970**.

More About Foaming

If the information on the previous page about dealing with excessive foaming did not help with your foaming problem, here are some less common issues to consider:

- **Oil skimming.** Your oil skimming could be removing defoamant. You can try adjusting the skimmer to operate when the solution cools and oils have floated to the surface and the defoamants has returned to the solution. However, if you are cleaning synthetic oils and greases, you should run your oil skimmer continuously; the buildup of synthetic oils will cause extra foam.
- **Contaminants with animal fat.** Greases and other contaminants that contain animal fat can cause extra foaming with alkaline chemicals.

If you are using a detergent other than Aluma-Klean, here are some other factors to consider:

- **Types of contaminants.** The type of contaminants on the parts you are washing can interact with the detergent, causing extra foaming. Check to see if your detergent is compatible with the operating temperature of the Parts Washer, the kinds of parts you are washing, and the types of metals in the parts you are washing. If the detergent is not compatible, change to a more compatible type.
- **Detergent concentration.** Make sure the concentration of the detergent you are using is compatible with the Parts Washer. If the concentration is too little or too much, it could be the source of the foaming.
- **Detergent type.** Make sure the detergent is formulated for high velocity and high impact washing of parts. Detergents not specifically developed for washing parts under these conditions can foam much more than normal when used in a Parts Washer.

Additional Aluma-Klean Safety Information

Your Parts Washer comes with Aluma-Klean detergent.

 **WARNING** Use care when handling Aluma-Klean detergent. It is harmful if swallowed, can cause severe skin burns and eye damage, and can cause respiratory irritation.

The [Material Data Safety Sheet for Aluma-Klean Detergent](#), which contains additional safety information about it, is available on the Ranger website.

First aid measures include:

- **Eyes.** Check for and remove contact lenses. Immediately flush eyes with water for at least 15 minutes, occasionally lifting the upper and lower eyelids. ***Get medical attention immediately.***
- **Skin.** In case of skin contact, immediately flush the skin with water for at least 15 minutes while removing contaminated clothing. Thoroughly wash clothing before reuse. Get medical attention if irritation develops.
- **Inhalation.** Move exposed person to fresh air. If irritation persists, get medical attention.
- **Ingestion.** Wash out mouth with water. Do not induce vomiting unless directed to do so by medical personnel. Never give anything by mouth to an unconscious person. If affected person is conscious, give plenty of water to drink. ***Get medical attention immediately.***

Wiring Diagrams

1 Phase Wiring Schematic

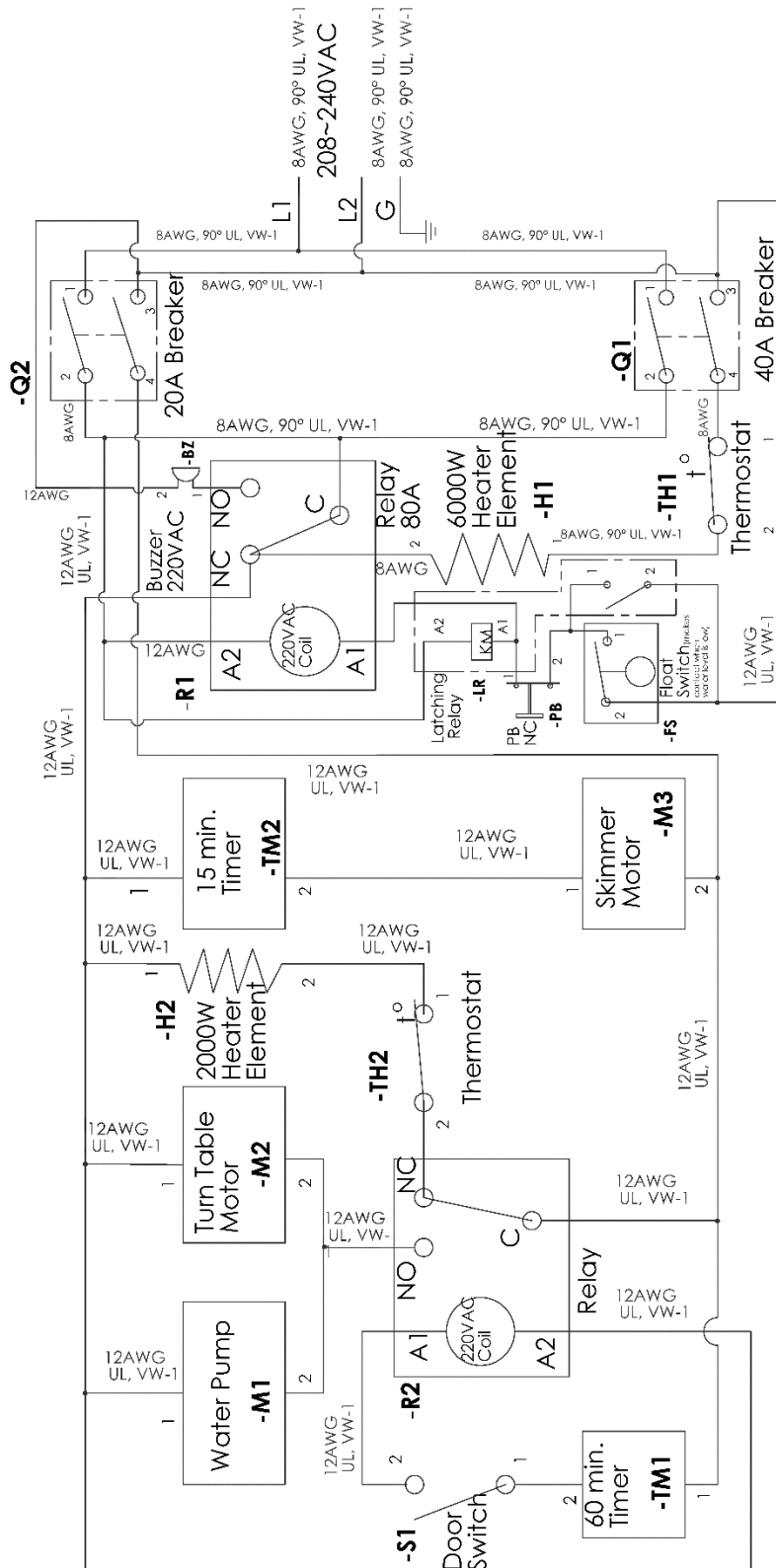

***Note for Float switch:**

-contact is close with low level water .
 -contact is open with higher level of water(like when tank is full of water).

Note2: Use only UL approved terminal blocks with 90° temp.

1 Phase Terminal Block Diagram

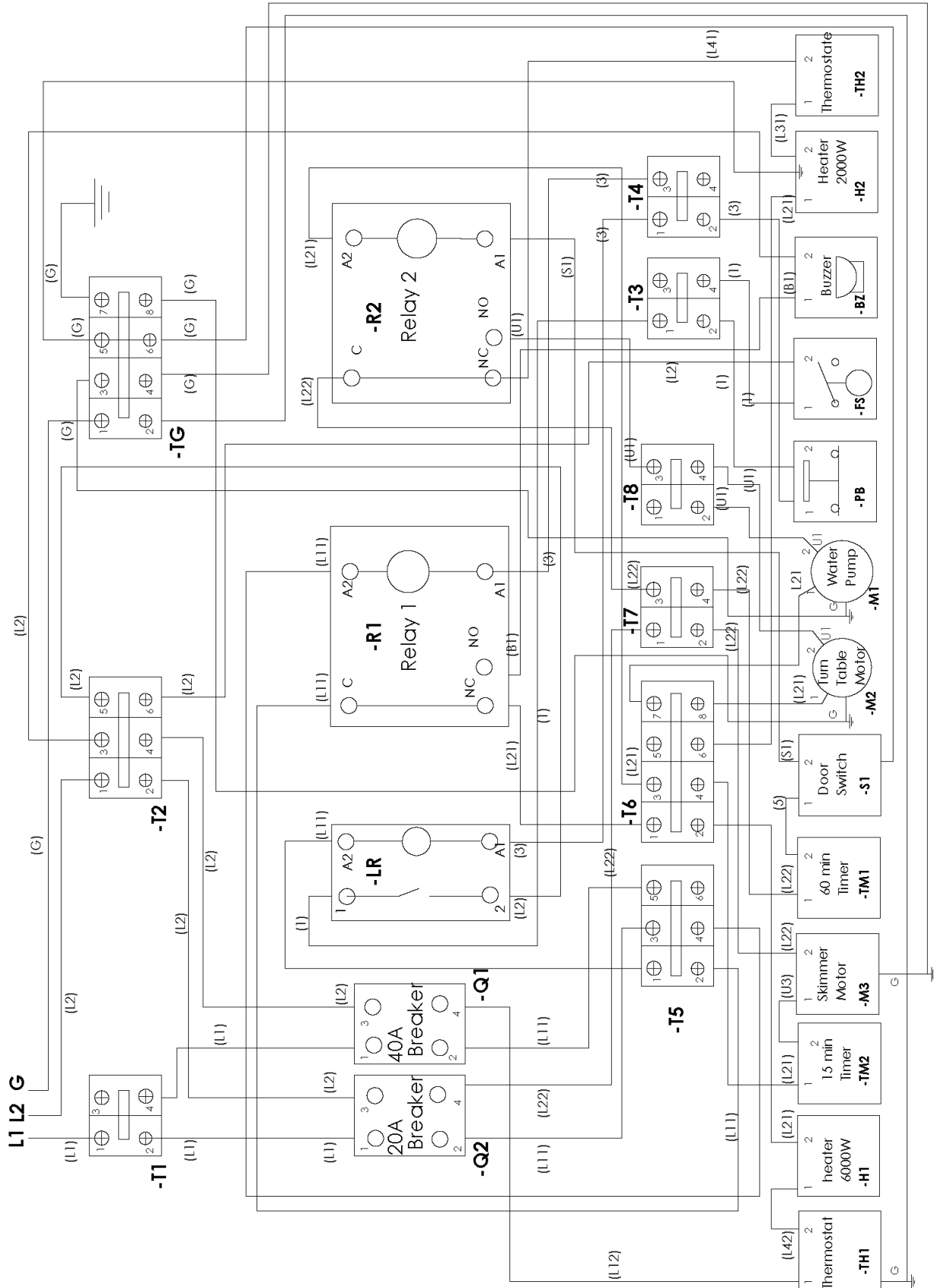

3 Phase Wiring Schematic

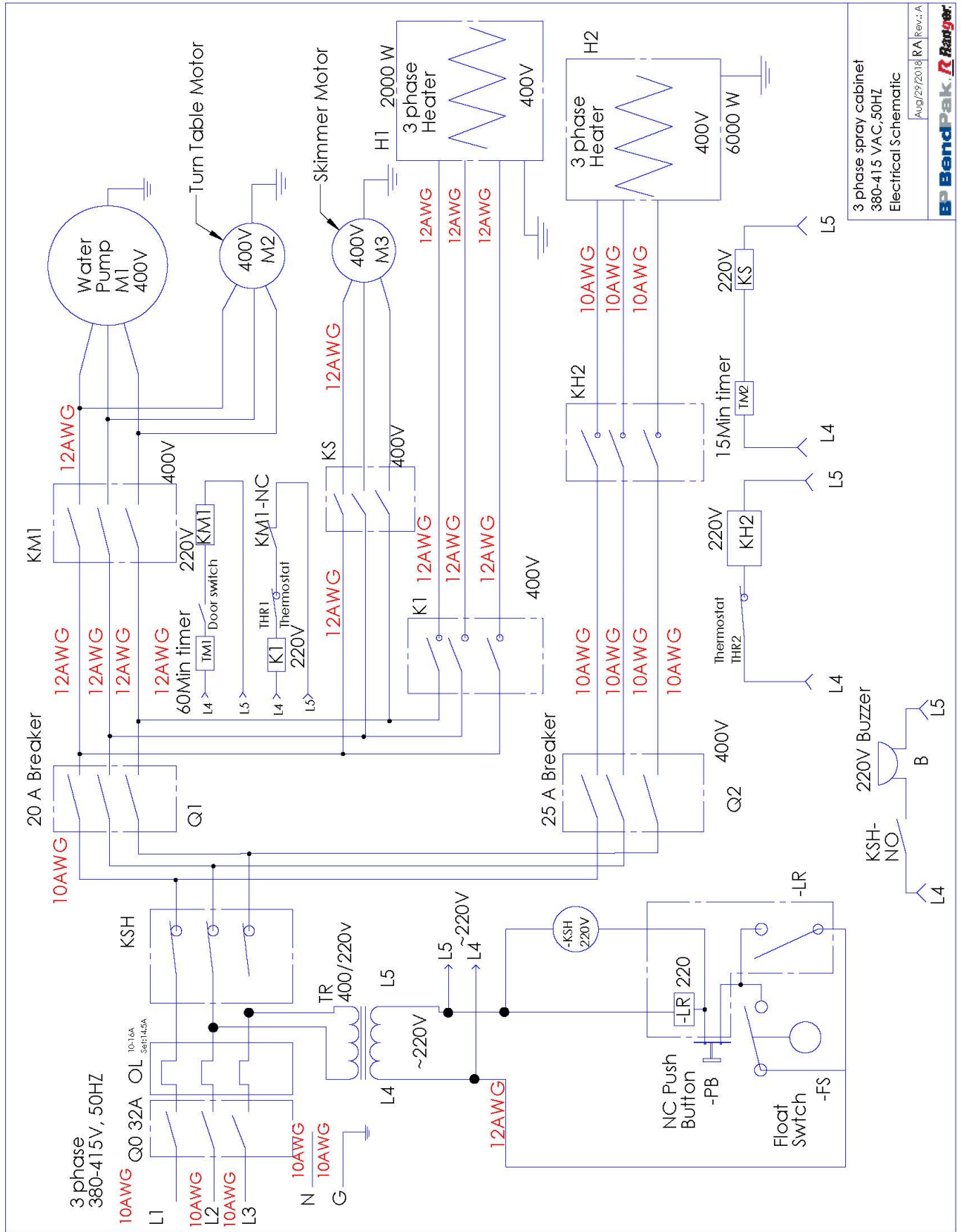

3 Phase Terminal Block Diagram

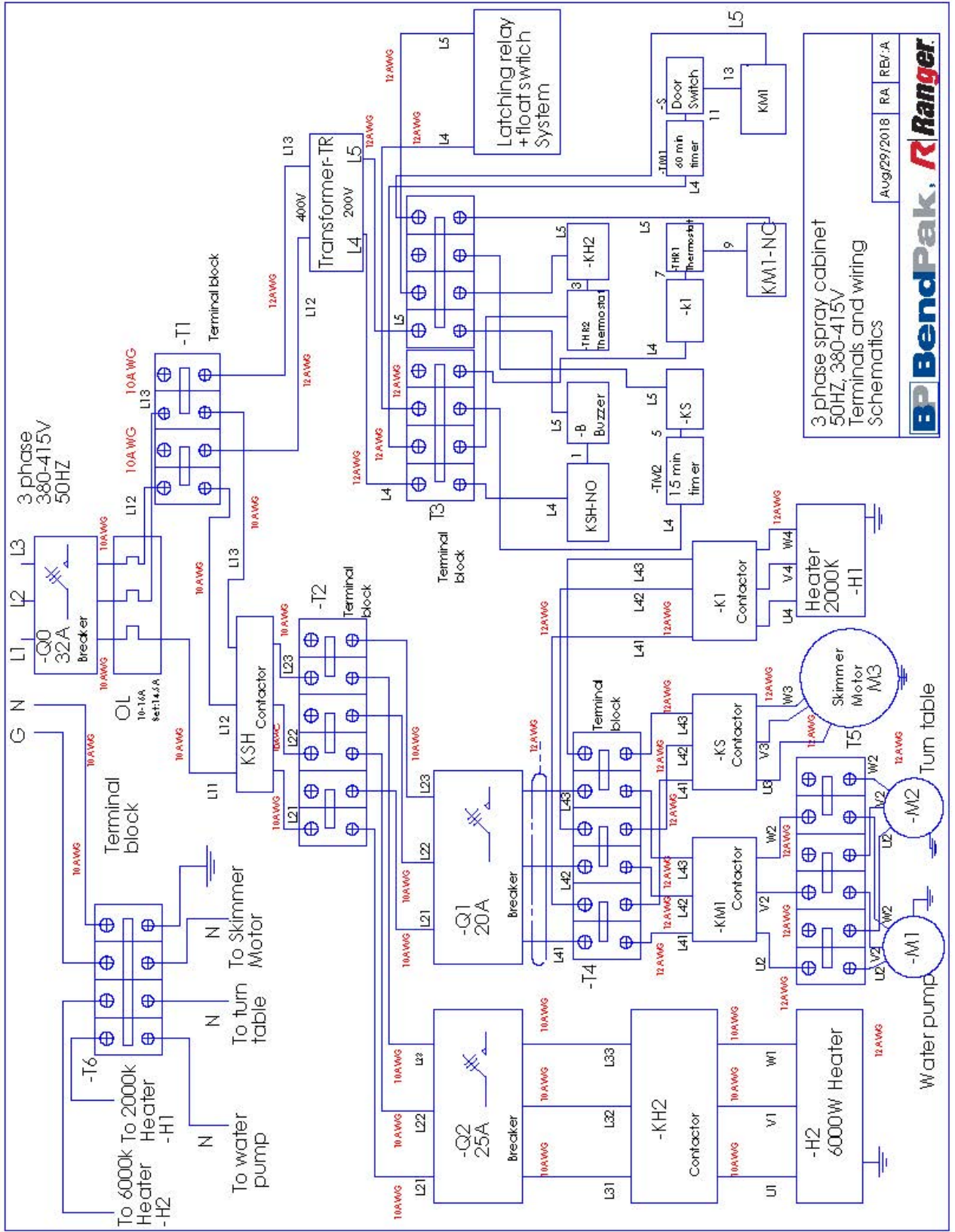

Labels

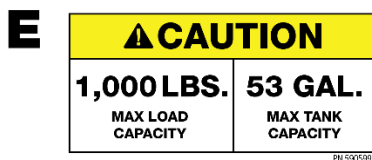
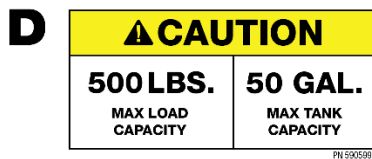
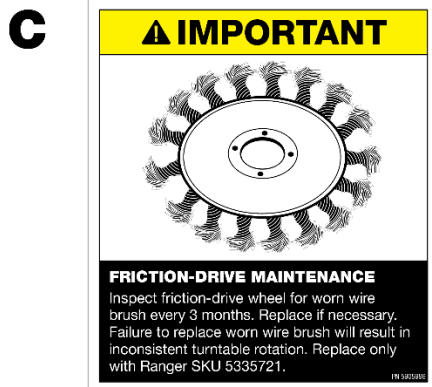

F

CAUTION

IMPORTANT WATER LEVEL WARNINGS
Under normal operating conditions the machine loses 3 to 5 gallons of water per day due to evaporation. It is important that you monitor and maintain the water level daily to minimize the risk of ruining the pump or burning out the heating elements.

- **ALWAYS** check water level daily
- **NEVER** allow water level to drop below pump inlet or heating elements
- **NEVER** operate machine if pump is sucking air
- Monitor the water level carefully – **DO NOT** overfill the machine
- Remove excess water using a small submersible pump or a suitable container
- The tank is full when the water level is at the lip. The water level float sensor will start to drop when the water level drops below 5 1/4" from the lip. The float sensor trips the alarm when the water level is somewhere between 5 1/4" and 5 3/4" below the lip.

IMPORTANT LOW WATER SHUT-OFF WARNINGS
This machine is equipped with a Low Water Shut-off Switch that shuts the system down if the wash solution in the water reservoir drops below a safe level. The Low Water Shut-off Switch is a liquid level float switch that is located inside the water reservoir, mid-level and to the left. The liquid level float switch monitors the water level automatically. If the wash solution drops below the lower proximity of the switch, the low water indicator light on the control panel turns on and the system stops all activities by disconnecting the power to the machine. To reset the system, add water to the reservoir until the low water indicator light turns off and Reset button is pressed. At that time all previously-running activities will resume.

CLEANING THE LOW WATER SHUT-OFF SWITCH

- To prevent electrical shock, **ALWAYS** turn off the electrical power before cleaning or making any repairs.
- Sediment build-up will cause switch to malfunction and prevent water level from being accurately monitored.
- Depending on use, **WEEKLY** or **MONTHLY** inspection and cleaning of the float mechanism is required.
- The float mechanism needs to be inspected and cleaned more frequently during heavy use or when there is a potential of excessive scale or sludge build-up.

The float mechanism should move up and down smoothly without hanging up or operating erratically.

IMPORTANT

OPERATING INSTRUCTIONS

0-60 MINUTE WASH TIMER: After latching the door, set this timer for the length of the automatic wash cycle. DO NOT open the door until the timer reaches "0".

DOOR SAFETY SWITCH: Prevents the spray pump (used in the automatic cycle) from coming on when the door is open. This is a safety switch that is not to be used for purposely stopping the wash cycle.

Make sure there is always water visible below the filter basket; could result in damage if not followed. Check daily. DO NOT use the washer until the solution has reached 160°F. Otherwise, foaming may occur.

MINIMIZE MACHINE WEAR AND TEAR: Rinse parts with clean water. Equipment or parts should be pre-cleaned of excess dirt and grease before placing in parts washer.

DETERGENT USE: To prevent clogging of spray nozzles, pre-mix this product before adding to the washer. Add 2-4 ounces of spray wash detergent to one gallon of water. Add small amount of pre-mixed detergent between batches to maintain concentration.

USE FACTORY APPROVED DETERGENT ONLY
Factory approved Aluma Klean™ is the only detergent approved for use with this automatic parts washer. Aluma Klean is an exclusively formulated detergent that is safe for use in aqueous heated high-pressure spray wash cabinets. It is specially formulated with pump seal conditioners to extend pump service life, rust inhibitors to protect your cabinet from corrosion, and anti-foaming agents to optimize performance and minimize maintenance. The use of any other detergent during the warranty period will void the warranty.

To order replacement detergent, visit www.bendpak.com

IMPORTANT NOTE: This wash cabinet will rust unless factory approved detergents are used. Use ONLY factory approved detergents with rust and corrosion inhibitors to protect the cabinet, pump and drive components. High alkaline, high pH or non-aqueous based detergents should NEVER be used in this washer.

SHUTTING DOWN THE MACHINE

WARNING! If the heater is left on unattended, the wash solution could evaporate and the oil and grease in the water reservoir could catch fire. For periods of extended shut-down, disconnect all power to the machine.

TO SHUT DOWN THE MACHINE:

1. Set the wash cycle timer to **OFF**
2. Set the oil skimmer timer to **OFF**
3. Set the heater main power switch to **OFF**
4. Set the main power switch to **OFF**

CLEANING OUT THE WATER RESERVOIR

WARNING! Always ensure your parts washer water reservoir is clean. Pump and heating elements could be damaged by continued build-up of sludge. Before disposing the spent washing solution and sludge build-up, check with your local EPA or sewer district for disposal regulations in accordance with applicable local, state, and federal codes.

TO MANUALLY CLEAN OUT THE WATER RESERVOIR, PERFORM THE FOLLOWING PROCEDURE:



1. Remove oil and grease from the cleaning solution using the oil skimmer system.
2. Remove the water reservoir cover and filter screen.
3. Remove the pipe cap on the outside front of the water reservoir (or use a small submersible pump) then drain the wash solution making sure the disposed solution is captured in accordance with applicable local, state, and federal regulations.
4. With the washing solution removed, use a plastic scraper or putty knife to remove all sand, sludge and other debris from the bottom of the water reservoir. Or vacuum it out using a wet/dry vac.
5. Use a garden hose to lightly spray inside the reservoir with clean water.
6. Ensure that the heating elements and water-level shutoff float are free of debris and sludge build-up.
7. Refill the water reservoir with fresh clean water.
8. Replace the water reservoir cover and filter screen and heat the wash water to operating temperature.
9. Add the appropriate amount of detergent and run the machine through a 30-minute wash cycle.

PN 5905997

G

⚠ WARNING PLEASE READ	SHOCK HAZARD	SKIN HAZARD	EYE HAZARD	FLAMMABLE HAZARD	BURN HAZARD
					
Read and understand manual before using this machine.	Disconnect power source before servicing this equipment.	Wear protective gloves when cleaning parts with solution to prevent contact with skin.	Safety glasses must be worn when using this equipment.	No smoking. Keep away from open flame and sparks. Close door when not in use.	DO NOT TOUCH. Keep hands away from hot surfaces. Allow to cool before servicing.

H

MODEL NO.	<input type="text"/>	SPRAY WASH CABINET  DANGER! Disconnect Power Before Servicing
SERIAL NO.	<input type="text"/>	
DATE OF MFG.	<input type="text"/>	
VOLTAGE	<input type="text"/>	
 1845 Lemonwood Drive Santa Paula, CA 93060 www.rangerproducts.com <small>Designed and Engineered by Ranger Products USA - Made in China</small>		

L (3Ph model only)

PN 5905041

Q0
Main Disconnect Switch

M (3Ph model only)

PN 5905042

Q1
Pump / Turntable / 2KW Heater

I

	⚠ WARNING Electrical shock hazard! Do NOT open. No user serviceable parts inside. Refer servicing to qualified service personnel only.
	<input type="checkbox"/> 208 - 240 VAC, 60 Hz, 1 Ph <input type="checkbox"/> 380 - 415 VAC, 50 Hz, 3 Ph

PN 5905040

N (3Ph model only)

PN 5905043

Q2
6000W Heater

K

(3Ph model only)

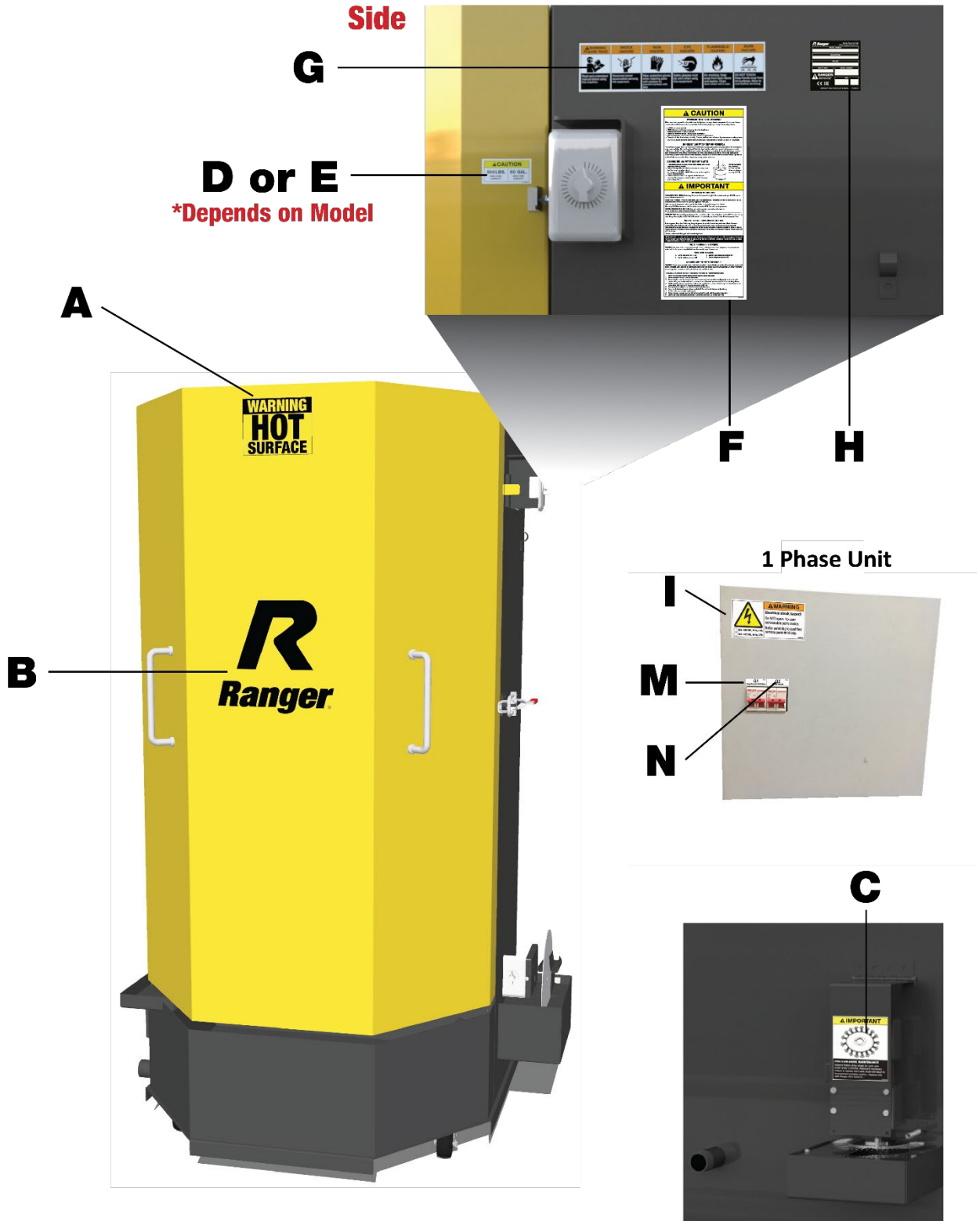

DANGER HIGH VOLTAGE Disconnect power before servicing

PN 5905043

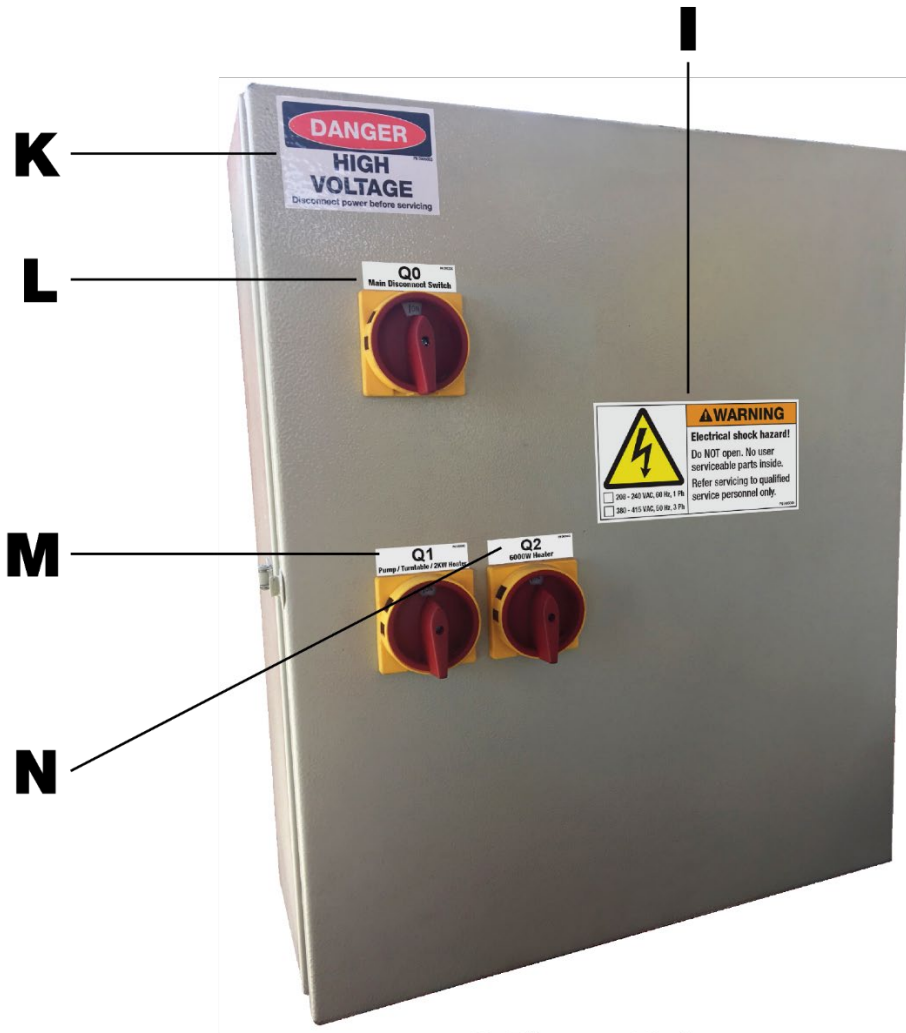

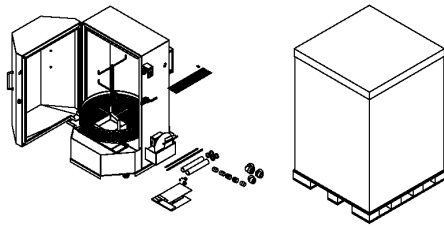

**3 Phase Unit
Electrical Box**



ITEM NO	PART NUMBER	DESCRIPTION	QTY	REV
41	5330365	FIG 45ELB -20 NPT X-20 NPT	1	--
42	5665602	Ø41mm RUBBER HOSE	914mm	--
43	5665603	Ø47mm RUBBER HOSE	914mm	--
44	5305486	HSS28 HOSE CLAMP	4	--
45	5320114	Ø12 LIQUID TIGHT CONDUIT NONMETALLIC	4262mm	--
46	5320125	RED WIRE NUT	4	--
47	5330051	HHB M6 x 1 x 12	4	--
48	5320128	10-3 SO. CABLE 300vac	3658mm	--
49	5334000	NUT M5 x 0.8	4	--
50	5320290	ROMEX CONNECTOR 3/4"	1	--
51	5900245	RS-500D/750D INSTALLATION MANUAL	1	--
52	5330019	HHB M6 x 1 x 16	1	--
53	5343009	WASHER, Ø4.3 x Ø9mm x 0.8mm	2	--
54	5320022	HORIZONTAL-MOUNT LIQUID LEVEL SWITCH 220VAC	1	A
55	5335002	RS-SERIES SENSOR BOX COVER	1	A
56	5300016	COTTER PIN 1.5 x 12 TPI	2	--
57	5320346	SPRAY WASH CONTROL PANEL ASSEMBLY	1	A
58	5335400	1 HOUR TIMER	1	--
59	5335425	HEATER ELEMENT, 6K	1	--
60	5335925	2000 WATT HEATER ELEMENT, RS-500/750	1	--
61	5335520	12 MPH LIQUID W/W PLATE	1	--
62	5335460	DOOR SAFETY SWITCH	1	--
63	5335530	OIL SKIMMER MOTOR	1	--
64	5335405	1 HP PUMP & MOTOR/RS-24 & RS-500	1	--
65	5335585	TURN TABLE DRIVE MOTOR	1	--
66	5335950	SPRAY WASHER ADJUSTABLE THERMOSTAT	1	--
67	5335540	THERMOSTAT, RS-SERIES	1	--
68	5910193	PACKING TOP BOX, RS-SERIES	1	A
69	5910194	PACKING BOTTOM BOX, RS-500	1	A
70	5940031	RS-SERIES PALLET ASSEMBLY	1	A
71	5380012	LIQUID PTFE THREAD SEALANT 50ml	1	A
--	5905003	Danger High Voltage Label	1	--
--	5905279	2017 Feet Oil Sealant Tag	1	--
--	5905304	Ranger Logo-Font	1	--
--	5905372	BPK-RNGR Inspect Decal	1	--
--	5905493	BPK-RNGR Fragile Decal	1	--
--	5905496	Warning Hot Surface Label	1	--
--	5905531	BPK-RNGR High Claim Item Decal	1	--
--	5905591	RS-SPRAY WASHER OPERATING INSTRUCTIONS	1	--
--	5905992	RS-SprayWasher Long Warning Label	1	--
--	5905996	RS-SprayWasher Friclon Drive Label	1	--
--	5905997	RS-500_Max_Capacity_Label	1	--

ITEM NO	PART NUMBER	DESCRIPTION	QTY	REV
1	5335145	RS-500D CABINET CHASSIS WELDMENT	1	R
2	5335150	RS-SERIES BASKET MOTOR COVER WELDMENT	1	A
3	5335100	RS-500D MOTOR ASSEMBLY	1	C
4	5335725	RS-SERIES HINGE PIN	2	A
5	5335740	RS-SERIES BASKET MOTOR HINGE PIN	1	C
6	5335430	RS-SERIES LAUNCH HANDLE ASSEMBLY	1	A
7	5335490	RS-SERIES FLANGE BLOCK BEARING	1	A
8	5335515	RS-SERIES BASKET WELDMENT	1	A
9	5335485	RS-500D PARTS HANGER TREE	1	B
10	5335470	RS-SERIES STRAINER BASKET	1	B
11	5335880	RS-500D LONG SPRAY PIPE ASSEMBLY	1	B
12	5335885	RS-SERIES HORIZONTAL SPRAYER ASSEMBLY	2	A
13	5701176	RS-SERIES SKIMMER MOTOR BOX COVER	1	A
14	5335795	RS-SERIES SIDE SPRAYER CLAMP	1	A
15	5335755	RS-SERIES TOP SPRAYER CLAMP	1	A
16	5335125	RS-SERIES DOOR CHAIN	1	A
17	5335425	RS-SERIES STRAINER BASKET	1	A
18	5335555	RS-SERIES BASKET MOTOR SPRING	2	A
19	5335725	RS-SERIES WIRE WHEEL BOX COVER	1	A
20	5335520	RS-SERIES SKIMMER WHEEL	1	A
21	5335525	RS-SERIES SKIMMER WHEEL WIPER WELDMENT	1	C
22	5335635	RS-SERIES HEATER BOX COVER	2	B
23	5335901	FIG IEE -20 NPT X-20 NPT F X-20 NPT F	1	--
24	5330302	FIG ELB RED -20 NPT X-1/4 NPT F	2	--
25	5330303	FIG NPT -20 NPT X-20 NPT	2	--
26	5330304	FIG C-AT -20 NPT F	2	--
27	5385003	RIVET Ø8mm	1	--
28	5335112	NUT M6 x 1.0	8	--
29	5335605	FIG C-AT -24 NPT F	1	--
30	5330302	HHB M8 x 1.25 x 12	4	--
31	5330780	HHB M8 x 0.8 x 20	4	--
32	5330045	HHB M5 x 0.8 x 10	16	--
33	5345701	WASHER M10 x Ø18 SL	4	--
34	5330738	HHB M10 x 1.5 x 25	6	--
35	5335998	NUT M10 x 1.5	6	--
36	5335525	Ø12 30MM WIRE WHEEL	1	--
37	5330303	FIG ELB -24 NPT X-20 NPT	1	--
38	5330030	FIG ELB -24 F NPT X-24 F NPT GAL	1	--
39	5330360	FIG NPT -20 NPT X-20 NPT GAL	3	--
40	5330048	FIG NPT -24 NPT X-24 NPT GAL	2	--

DO NOT SCALE DRAWING

DRAWN	TM	05/04/2011	EP BendPak. 1645 LEMONWOOD DR. SANTA PAULA, CA 93060
CHECKED	OR	1/22/2021	
THIRD ANGLE PROJECTION			TITLE: RS-500D RECEIVED SPRAY WASH CABINET
SIZE	DWG. NO.	REV	
A	5260500	Y	
SCALE: 1:50			SHEET 1 OF 5

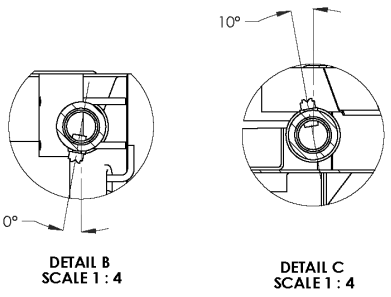
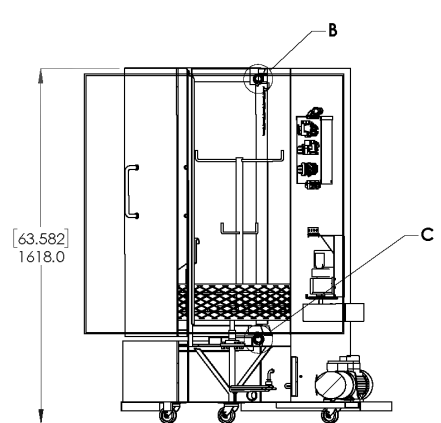
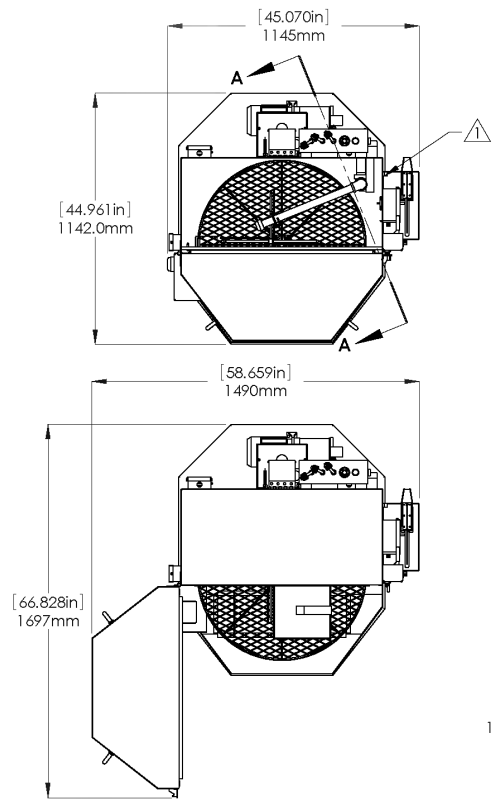

⚠ 5335355 HIDDEN FOR CLARITY

EP BendPak.
1645 LEMONWOOD DR.
SANTA PAULA, CA 93060

TITLE: RS-500D RECEIVED SPRAY WASH CABINET

SIZE	DWG. NO.	REV
A	5260500	Y
SCALE: 1:20		SHEET 4 OF 5

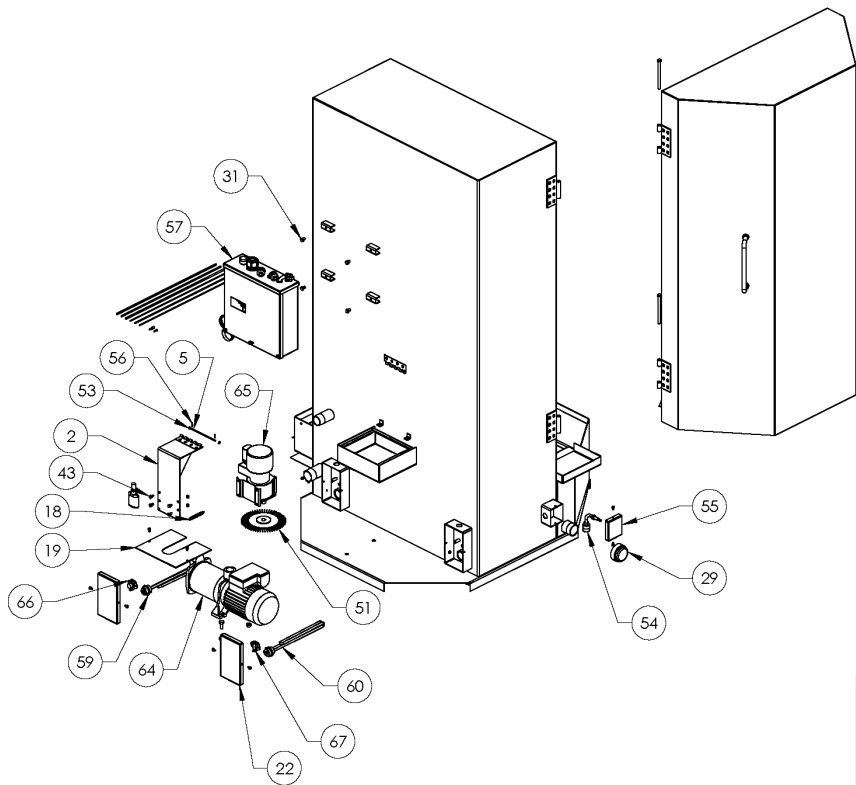

BendPak.		
1645 LEMONWOOD DR. SANTA PAULA, CA 95060		
TITLE: RS-750D RECEIVED SPRAY WASH CABINET		
SIZE	DWG. NO.	REV
A	5260505	Y
SCALE: 1:18		SHEET 3 OF 5

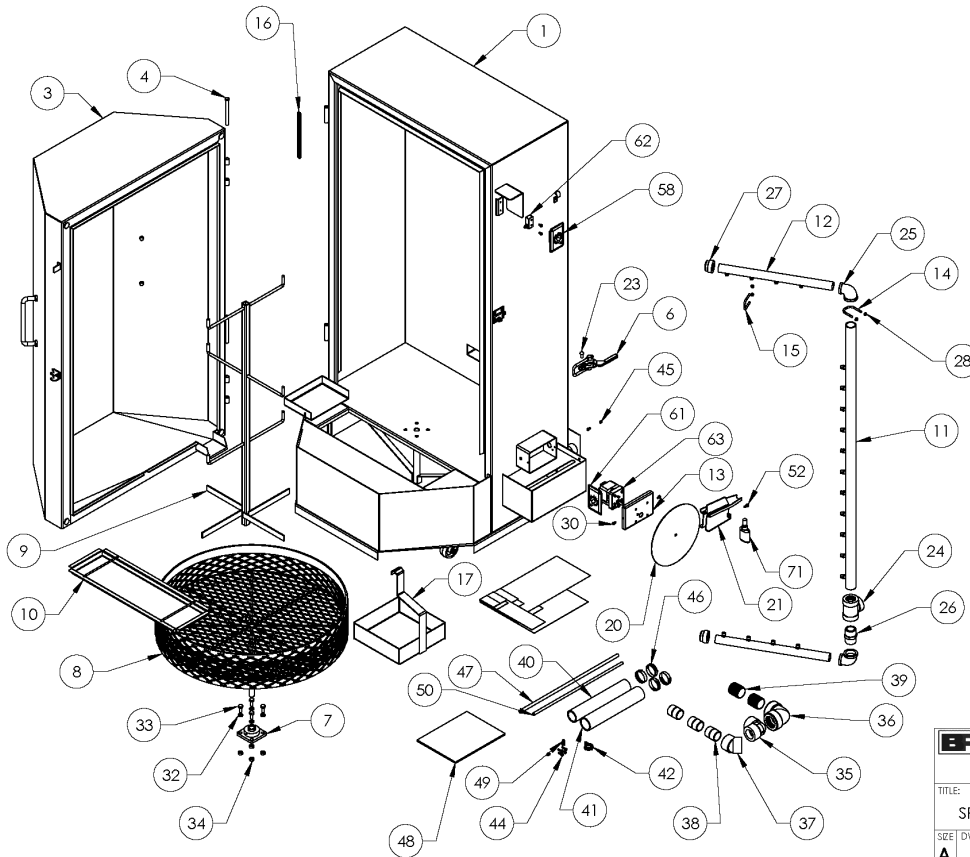

BendPak.		
1645 LEMONWOOD DR. SANTA PAULA, CA 95060		
TITLE: RS-750D RECEIVED SPRAY WASH CABINET		
SIZE	DWG. NO.	REV
A	5260505	Y
SCALE: 1:18		SHEET 2 OF 5

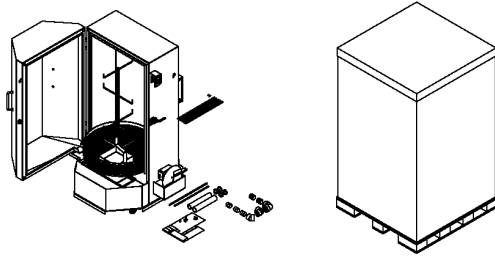

ITEM NO.	PART NUMBER	DESCRIPTION	QTY	REV
40	5665602	Ø41mm RUBBER HOSE	914mm	A
41	5665603	Ø47mm RUBBER HOSE	914mm	A
42	552022	ROMEX CONNECTOR 3/4"	4	--
43	5330031	HHB M6 x 1 x 12	4	--
44	5530780	HHB M5 x 0.8 x 20	4	--
45	5535400	NUT M5 x 0.8	4	--
46	5505686	HSS28 HOSE CLAMP	4	--
47	5920114	Ø12 LIQUID TIGHT CONDUIT NONMETALLIC	4267mm	--
48	5900245	RS-500D/750D INSTALLATION MANUAL	1	--
49	5520125	RED WIRE NUT	1	--
50	5570128	10-3 SO CABT 300vac	3658mm	--
51	5335563	Ø17.5mm WIRE WHEEL	1	--
52	5530019	HHB M6 x 1 x 16	1	--
53	5545009	WASHER Ø4.3 x Ø9mm x 0.8mm	2	--
54	5520022	HORIZONTAL-MOUNT LIQUID LEVEL SWITCH 220VAC	1	--
55	5335002	RS-SERIES SENSOR BOX COVER	1	A
56	5505016	COTTER PIN 1.5 x 12 7PL	2	--
57	5520646	SPRAY WASH CONTROL PANEL ASSEMBLY	1	A
58	5335400	1 HOUR TIMER	1	--
59	5335425	HEATER ELEMENT 6K	1	--
60	5335925	2000 WATT HEATER ELEMENT RS-500/750	1	--
61	5335560	15 MIN TIMER W/SW PLATE	1	--
62	5335460	DOOR SAFETY SWITCH	1	--
63	5335530	OIL SKIMMER MOTOR	1	--
64	5335405	1 HP PUMP & MOTOR/RS-250 & RS500	1	--
65	5335585	TURN TABLE DRIVE MOTOR	1	--
66	5335950	SPRAY WASHER ADJUSTABLE THERMOSTAT	1	--
67	5335540	THERMOSTAT RS-SERIES	1	--
68	5940031	RS-SERIES PALLET ASSEMBLY	1	A
69	5910196	PACKING BOTTOM BOX; RS-750	1	A
70	5910193	PACKING TOP BOX; RS-SERIES	1	A
71	5580012	LIQUID PTFE THREAD SEALANT 50ml	1	A
--	5905998	RS-750 Max Capacity Label	1	--
--	5905996	RS-SprayWasher Friction Drive Label	1	--
--	5905992	RS-SprayWasher Long Warning Label	1	--
--	5905991	RS-SPRAY WASHER OPERATING INSTRUCTIONS	1	--
--	5905531	BPK-RNGK High Claim Item Decal	1	--
--	5905496	Warning Hot Surface Label	1	--
--	5905493	BPK-RNGK Fragile Decal	1	--
--	5905372	BPK-RNGK Inspac I Decal	1	--
--	5905304	Ranger Logo-Front	1	--
--	5905279	2017 Peel Off Serial Tag	1	--
--	5905003	Danger High Voltage Label	1	--

ITEM NO.	PART NUMBER	DESCRIPTION	QTY	REV
1	5335130	RS-750D CABINET CHASSIS WELDMENT	1	R
2	5335130	RS-SERIES BASKET MOTOR COVER WELDMENT	1	A
3	5335105	RS-750D DOOR ASSEMBLY	1	C
4	5335765	RS-SERIES HINGE PIN	2	A
5	5335740	RS-SERIES BASKET MOTOR HINGE PIN	2	C
6	5335430	RS-SERIES LATCH HANDLE ASSEMBLY	1	A
7	5335490	RS-SERIES FLANGE BLOCK BEARING	1	A
8	5335115	RS-SERIES BASKET WELDMENT	1	A
9	5335160	RS-750D PARTS HANGER ASSEMBLY	1	B
10	5335470	RS-SERIES STRAINER BASKET	1	B
11	5335890	RS-750D LONG SPRAY PIPE ASSEMBLY	2	B
12	5335895	RS-SERIES HORIZONTAL SPRAYER ASSEMBLY	2	A
13	5701176	RS-SERIES SKIMMER MOTOR BOX COVER	1	A
14	5335795	RS-SERIES SIDE SPRAYER CLAMP	1	A
15	5335755	RS-SERIES TOP SPRAYER CLAMP	1	A
16	5335125	RS-SERIES DOOR CHAIN	1	A
17	5335475	RS-SERIES STRAINER BASKET	1	A
18	5335555	RS-SERIES BASKET MOTOR SPRING	2	A
19	5335725	RS-SERIES WIRE WHEEL BOX COVER	1	A
20	5335950	RS-SERIES SKIMMER WHEEL	1	A
21	5335925	RS-SERIES SKIMMER MOTOR WELDMENT	1	C
22	5335635	RS-SERIES HEATER BOX COVER	2	B
23	5386003	RIVET Ø8mm	1	--
24	5550301	FIG IFF -20 NPT F x 20 NPT F x 20 NPT F	1	--
25	5550302	FIG IFF RED -20 NPT F x 16 NPT F	2	--
26	5550303	FIG NPT -20 NPT x 20 NPT	1	--
27	5550304	FIG CAP -20 NPT F	2	--
28	5335112	NUT M6 x 1.0	8	--
29	5335605	FIG CAP -24 NPT F	1	--
30	5330045	BHPS M5 x 0.8 x 10	16	--
31	5330025	HHB M6 x 1.25 x 12	4	--
32	5545700	WASHER M10 x Ø18 SL	4	--
33	5530738	HHB M10 x 1.5 x 25	6	--
34	5335998	NUT M10 x 1.5	6	--
35	5550355	FIG ELB -20 F NPT x 20 F NPT	1	--
36	5550350	FIG ELB -24 F NPT x 24 F NPT GAL	1	--
37	5550365	FIG 45ELB -20 NPT x 20 NPT	1	--
38	5550360	FIG NPT -20 NPT x 20 NPT GAL	3	--
39	5550048	FIG NPT -24 NPT x 24 NPT GAL	2	--

DO NOT SCALE DRAWING

DRAWN: TM DATE: 05/04/2011

CHECKED: OR DATE: 1/22/2021

THIRD ANGLE PROJECTION

TITLE: RS-750D RECEIVED SPRAY WASH CABINET

SIZE: DWG. NO. 5260505 REV Y

SCALE: 1:50 SHEET 1 OF 5

EP BendPak
1445 LEMONWOOD DR.
SANTA PAULA, CA 93060

PROPRIETARY AND CONFIDENTIAL
THE INFORMATION CONTAINED IN THIS DRAWING IS THE PROPERTY OF BENDPAK INC. ANY REPRODUCTION IN PART OR AS A WHOLE WITHOUT THE WRITTEN PERMISSION OF BENDPAK INC. IS PROHIBITED.

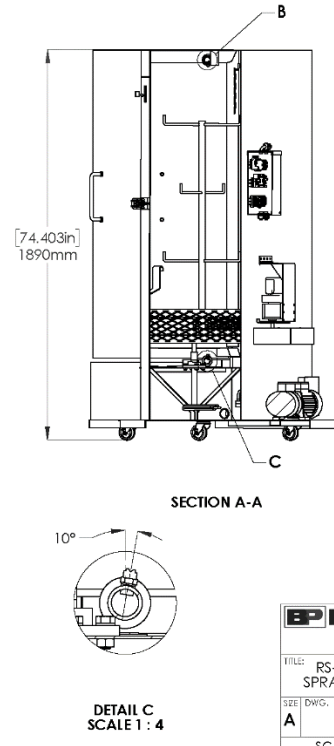
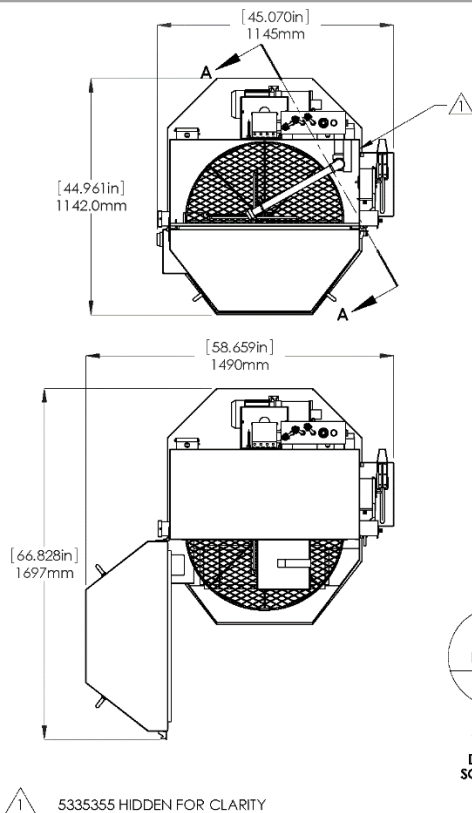

EP BendPak
1445 LEMONWOOD DR.
SANTA PAULA, CA 93060

TITLE: RS-750D RECEIVED SPRAY WASH CABINET

SIZE: DWG. NO. 5260505 REV Y

SCALE: 1:20 SHEET 4 OF 5



1645 Lemonwood Drive
Santa Paula, CA 93060 USA