

## Oil Filter Crusher

# Installation and Operation Manual

Manual P/N 5900011 — Manual Revision B1 — February 2021

Model:

- RP-20FC

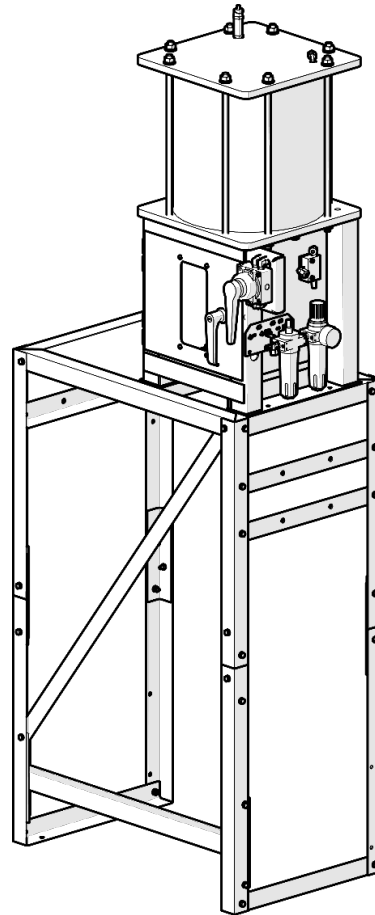

**Designed and engineered by BendPak Inc. in Southern California, USA. Made in China.**

 **DANGER**

**Read the *entire contents* of this manual *prior* to setup or operation. Failure to follow the instructions and safety precautions in this manual can result in serious injury or death. Make sure all other operators also read this manual. Keep the manual near the product for reference. *By proceeding with setup and operation, you agree that you fully understand the contents of this manual and assume full responsibility for product use.***

**Manual.** RP-20FC Oil Filter Crusher, *Installation and Operation Manual*, Manual P/N 5900011, Manual Revision B1, Released February 2021.

**Copyright.** Copyright © 2021 by BendPak Inc. All rights reserved. You may make copies of this document if you agree that: you will give full attribution to BendPak Inc., you will not make changes to the content, you do not gain any rights to this content, and you will not use the copies for commercial purposes.

**Trademarks.** BendPak, the BendPak logo, Ranger, and the Ranger logo are registered trademarks of BendPak Inc. All other company, product, and service names are used for identification only. All trademarks and registered trademarks mentioned in this manual are the property of their respective owners.

**Limitations.** Every effort has been made to ensure complete and accurate instructions are included in this manual. However, product updates, revisions, and/or changes may have occurred since this manual was published. BendPak Ranger reserves the right to change any information in this manual without incurring any obligation for equipment previously or subsequently sold. BendPak Ranger is not responsible for typographical errors in this manual. You can always find the latest version of the manual on the BendPak website.

**Warranty.** The BendPak Ranger warranty is more than a commitment to you: it is also a commitment to the value of your new product. For full warranty details and to register your new BendPak Ranger product, contact your nearest BendPak Ranger dealer or visit [www.bendpak.com/support/warranty](http://www.bendpak.com/support/warranty).

**Safety.** Your new product was designed and manufactured with safety in mind. Your safety also depends on proper training and thoughtful operation. Do not set up, operate, maintain, or repair the unit without reading and understanding this manual and the labels on the unit.

**Owner Responsibility.** In order to maintain your product properly and to ensure operator safety, it is the responsibility of the product owner to read and follow these instructions:



- Follow all setup, operation, and maintenance instructions.
- Make sure product setup conforms to all applicable local, state, and federal codes, rules, and regulations, such as state and federal OSHA regulations and electrical codes.
- Read and follow all safety instructions. Keep them readily available for operators.
- Make sure all operators are properly trained, know how to safely operate the unit, and are properly supervised.
- Do not operate the product until you are certain that all parts are in place and operating correctly.
- Carefully inspect the product on a regular basis and perform all maintenance as required.
- Service and maintain the unit only with approved replacement parts.
- Keep the manual with the product and make sure all labels are clean and visible.

**Unit Information.** Enter the Model Number, Serial Number, and the Date of Manufacture from the label on your unit. This information is required for part or warranty issues.

Model: \_\_\_\_\_

Serial: \_\_\_\_\_

Date of Manufacture: \_\_\_\_\_

		Santa Paula, CA USA www.rangerproducts.com	
MODEL NUMBER			
SERIAL NUMBER			
VOLTAGE			
DESCRIPTION			
DATE OF MFG.			
 <b>DANGER!</b> Disconnect Power Before Servicing			
WARRANTY VOID IF DATA PLATE IS REMOVED PN 5905279			

---

# Table of Contents

<b>Introduction</b> .....	<b>3</b>	<b>Operation</b> .....	<b>12</b>
<b>Shipping Information</b> .....	<b>4</b>	<b>Maintenance</b> .....	<b>13</b>
<b>Safety Considerations</b> .....	<b>4</b>	<b>Troubleshooting</b> .....	<b>13</b>
<b>Specifications</b> .....	<b>6</b>	<b>Labels</b> .....	<b>14</b>
<b>Components</b> .....	<b>7</b>	<b>Parts Drawings</b> .....	<b>15</b>
<b>Setup</b> .....	<b>8</b>	<b>Maintenance Log</b> .....	<b>17</b>

## Introduction

This manual describes the RP-20FC, which is an Oil Filter Crusher from BendPak Ranger, which applies up to 10 tons of air-operated pressure to flatten just about any used oil filter to approximately 20 percent of its size while removing up to 95 percent of the leftover oil.

More information about the full line of Ranger Products is available at [rangerproducts.com](http://rangerproducts.com).

***This manual is mandatory reading for all users*** of the RP-20FC.

**⚠ DANGER** Be very careful when setting up, operating, maintaining, or repairing this equipment; failure to do so could result in property damage, product damage, injury, or (in very rare cases) death. Make sure only authorized personnel operate this equipment. All repairs must be performed by an authorized technician. Do not make modifications to the unit; this voids the warranty and increases the chances of injury or property damage. Make sure to read and follow the instructions on the labels on the unit.

Keep this manual on or near the equipment so that anyone who uses or services it can read it.

Technical support and service for your oil filter crusher is available directly from your distributor or by calling the **Ranger Products Hotline at 1 (805) 933-9970**. You may also contact the Hotline for consultation on parts replacement (please have the serial number and model number of your unit available).

---

# Shipping Information

Your equipment was carefully checked before shipping. Nevertheless, you should thoroughly inspect the shipment **before** you sign to acknowledge that you received it.

When you sign the bill of lading, it tells the carrier that the items on the invoice were received in good condition. **Do not sign the bill of lading until after you have inspected the shipment.** If any of the items listed on the bill of lading are missing or damaged, do not accept the shipment until the carrier makes a notation on the bill of lading that lists the missing or damaged goods.

If you discover missing or damaged goods **after** you receive the shipment and have signed the bill of lading, notify the carrier at once and request the carrier to make an inspection. If the carrier will not make an inspection, prepare a signed statement to the effect that you have notified the carrier (on a specific date) and that the carrier has failed to comply with your request.

It is difficult to collect for loss or damage after you have given the carrier a signed bill of lading. If this happens to you, file a claim with the carrier promptly. Support your claim with copies of the bill of lading, freight bill, invoice, and photographs, if available. Our willingness to assist in helping you process your claim does not make us responsible for collection of claims or replacement of lost or damaged materials.

## Safety Considerations

**Read this manual carefully before using your new product.** Do not set up or operate the product until you are familiar with all operating instructions and warnings. Do not allow anyone else to operate the product until they are also familiar with all operating instructions and warnings.

### Safety Information

Please note the following:

- The product is an Oil Filter Crusher. **Use it only for its intended purpose.**
- The product should only be operated by authorized personnel. Keep children and untrained personnel away from the product.
- Do not crush aerosol cans, compressed gas, fuel filters, or flammable liquids or solvents.
- Do not stack cans or filters inside the press chamber; you could end up jamming the unit or even damaging it.
- Do not open the door while the unit is operating; always wait for the end of the cycle.
- When using the product, wear appropriate work clothes and ANSI-approved safety goggles. Do not wear loose clothing or jewelry. Keep hair and clothing away from moving parts.
- Before use, make sure all tools and/or debris are removed from the press area.
- When the product is in use, keep all body parts away from it.
- Do not use the product while tired or under the influence of drugs, alcohol, or medication.
- Do not use the product in the presence of cigarette smoke, dust, or flammable liquids or gases. Use the product indoors in a well-ventilated area.
- Do not make any modifications to the product.
- Never attempt to service the unit while it is connected to the air supply.
- Secure the unit to a dry, clean, flat concrete surface; do not install it on asphalt or wood.

- 
- Make sure all operators read and understand the *Installation and Operation Manual*. Keep the manual near the device at all times.
  - Make a visual inspection of the product before using it. Do not use the product if you find any missing or damaged parts. Instead, contact an authorized repair facility, your distributor, or the Ranger Products Hotline at 1 (805) 933-9970.
  - BendPak Ranger recommends making a **thorough** inspection of the product at least once a year. Replace any damaged or severely worn parts, decals, or warning labels.

## Symbols

Following are the symbols used in this manual:



**DANGER**

Calls attention to a hazard that **will** result in death or injury.



**WARNING**

Calls attention to a hazard or unsafe practice that **could** result in death or injury.



**CAUTION**

Calls attention to a hazard or unsafe practice that could result in personal injury, product damage, or property damage.



**Tip**

Calls attention to information that can help you use your unit better.

## Liability Information

BendPak Ranger assumes **no** liability for damages resulting from:

- Use of the equipment for purposes other than those described in this manual.
- Modifications to the equipment without prior, written permission from BendPak Ranger.
- Injury caused by modifying, disabling, overriding, or removing safety features.
- Damage to the equipment from external influences.
- Incorrect operation of the equipment.

# Specifications

Height	29.5" / 749 mm
Width	17" / 432 mm
Depth	17" / 432 mm
Chamber height	11" / 279 mm
Chamber width	8" / 203 mm
Chamber depth	11" / 279 mm
Average cycle time	15-20 seconds
Air Input	125 – 175 PSI

**Top View**

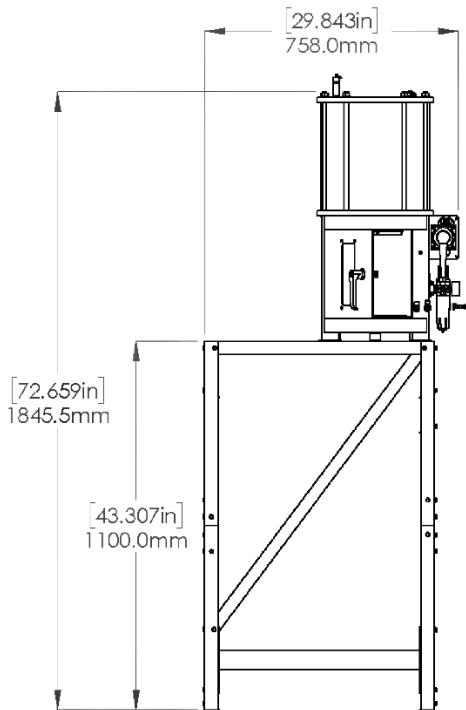
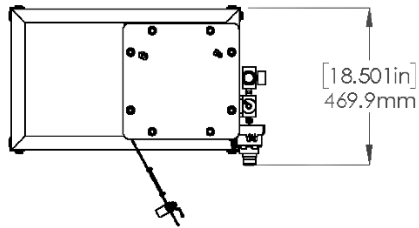

**Front View**

**Side View**

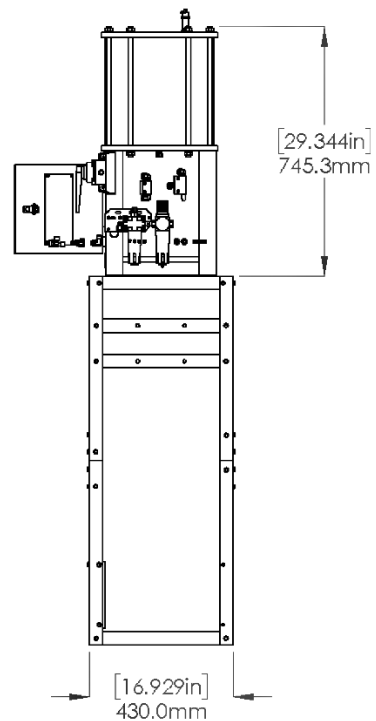

# Components

The following figure shows the major components of the unit.

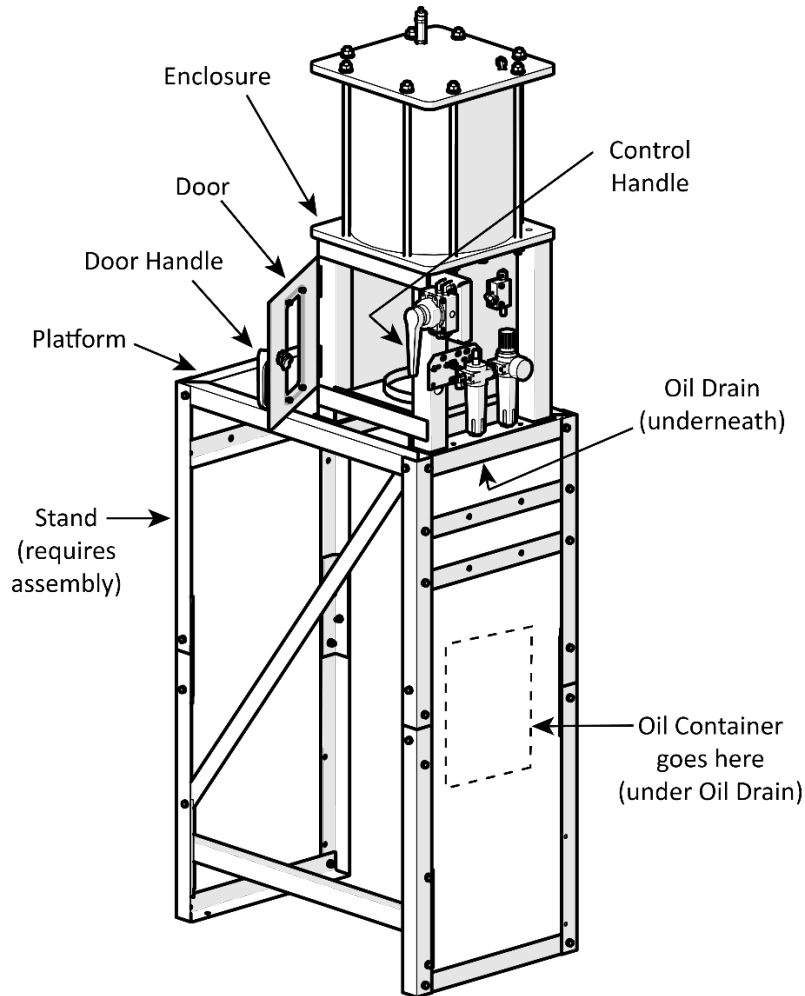

The main components of the RP-20FC are:

- **Enclosure.** Includes the crushing chamber, the Door, the Window, the Press Ram, and the Control Handle. Gets bolted to the top of the Platform.
- **Door.** Opens so that you can put in cans to be crushed. Door must be locked shut before you can crush what is inside.
- **Door Handle.** Press the button and turn up and to the Left to open the Door, press the button and turn to the Right and down to close the Door. Hold the button to open or close the Door.
- **Control Handle.** Move to the Left to bring down the Ram and crush the can in the unit, move to the Right to raise the Ram.
- **Platform.** Holds the Can Crusher on the Stand Platform.
- **Stand.** Raises the Can Crusher up high enough and wide enough to support a 55 gallon oil container for collection of used oil.
- **Oil Drain.** Where all of the used oil from the crushing process ends up. You definitely want an Oil Container in place to catch the oil that comes from the Oil Drain.
- **Oil Container.** *Not supplied.* The container you use to catch the oil from the crushing process

---

# Setup

This section describes how to get your oil filter crusher up and running.

## Tools and Supplies

You need to provide the following:

- Wrenches and screwdrivers appropriate for assembling the unit.
- A drill and concrete drill bit to mount the unit to the floor, if desired.
- Forklift or other lifting device



## Finding a Location

Keep the following in mind when deciding on a location:

- **Floor.** The unit is best used on a flat, concrete floor. **Do not** install on asphalt or wood surfaces.
- **Accessibility.** You need a little space around the unit to move the Oil Filters in and then to remove them.
- **Danger.** When the unit is crushing an Oil Filter, only the Technician should be near it. Everyone else must be kept at least 30 feet away from the unit.

***Do not set up the Oil-Filter Crusher in a well-travelled area.***

## Unpacking

Use caution when unpacking the components from their shipping containers. You do not want to damage or misplace anything.



### Tip

Consider unpacking the components in the area where you are going to assemble the unit. The fewer times you have to move the components, the fewer opportunities there are for them to get lost, get damaged, or damage the surface they are on.



---

## Assemble the Stand

The Stand comes disassembled (to protect the components during shipping).

The following graphic shows the components of the Stand.

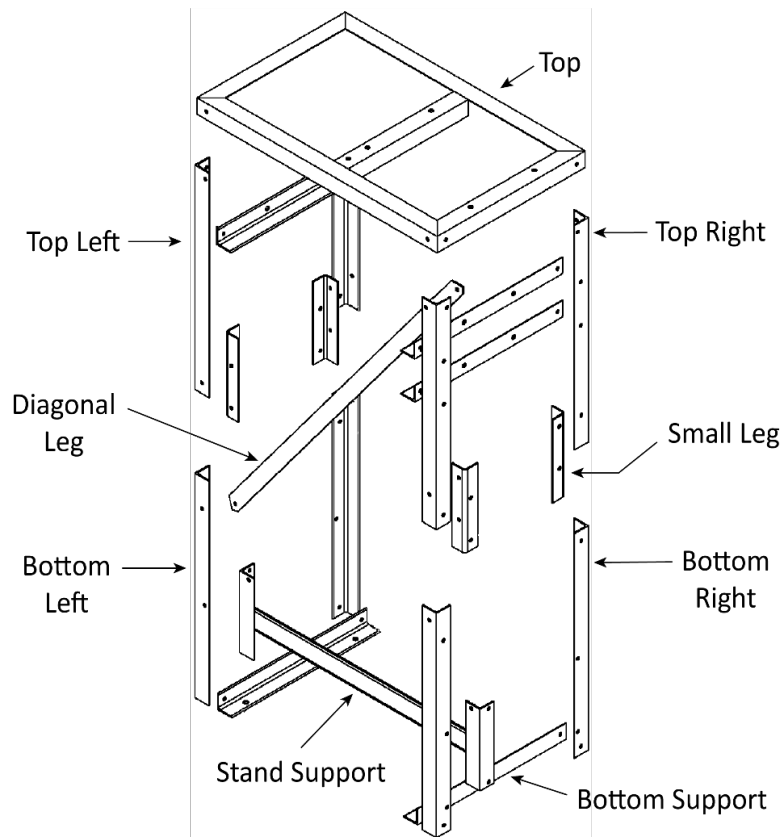

### To assemble the Stand:

1. Arrange all of the Stand components near where you are going to assemble it.
2. Lay the Top flat on the ground, with the inside facing up.
3. Attach the Top Lefts (2) and Top Rights (2) to the Top using the included M6 Bolts, M6 Washers, Split-Lock Washers and M6 Nuts.

**Important:** The Legs look similar but they are *not* interchangeable. The Top pieces are different from the Bottom pieces and the Left Legs are different from the Right Legs. We recommend laying them out to make sure you have the right sections in the right places **before** connecting them.

4. Connect a Small Leg (4) to each Leg, and then connect the Bottom Lefts (2) and Bottom Rights (2) to the corresponding Legs.
5. Attach the Top Supports (2) and Bottom Supports (2) to the Stand.
6. Attach the Diagonal Leg to the top of the Stand, put the Stand Support in place near the bottom of the Stand, and then secure the bottom end of the Diagonal Leg (1) and Side Supports (2) in place.
7. Move the Stand to the upright position.

## Bolt the Enclosure to the Stand

Once the Stand is assembled, secure the Enclosure over the open area of the Stand.

### To bolt the Enclosure to the Stand:

1. Using a Forklift or other lifting device, *carefully* lift the Enclosure out of the shipping box and over the opening in the Stand.

We recommend to wrap a Strap around the top portion of the Unit.

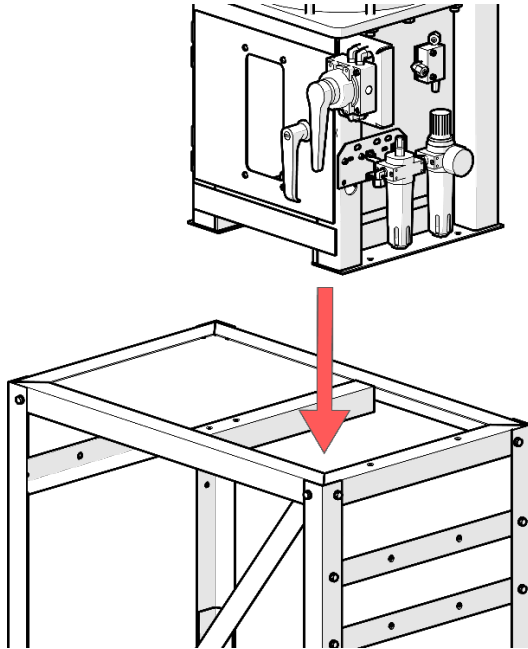

2. Secure the Enclosure to the Stand using four Bolts, Washers, and Nuts.
3. Connect the Drain Hose Fitting to the bottom of the Enclosure.
4. Attach the Hose Clamp and Drain Hose to the Enclosure.

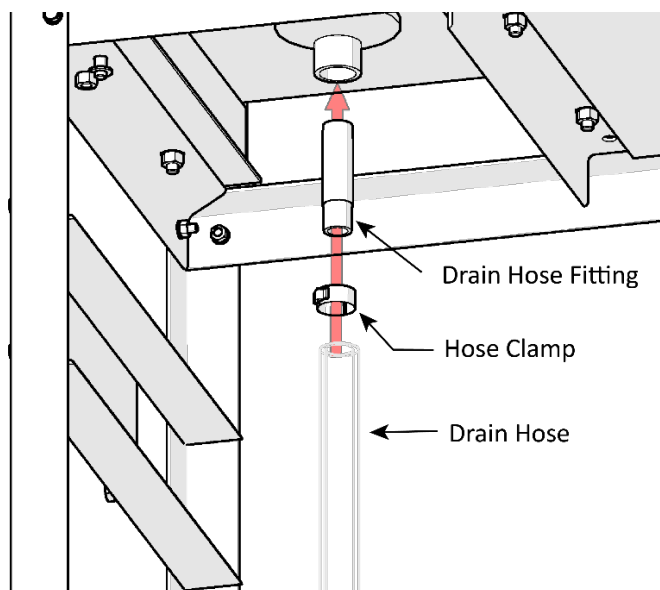

*Mounting Brackets for Power Unit not shown for clarity.*

## Connect the Air Lines

Connect the Air Lines to the Fittings on the Unit. The Air Line comes as one long roll of tubing; you need to cut it into sections of the right length.

Each connector on the Elbow and Straight Compression Fittings have a Nut, Ferrule, and Threads. The Nut holds the tubing and Fitting together. The Ferrule compresses when you tighten the Nut on the Threads to make a secure connection.

**Important:** ***Ferrules can only be used once.*** When you tighten the Nuts on the Threads, the Ferrule gets compressed; it changes shape and **cannot** be used again.

The following drawing shows the Air Line connections to make to the Unit.

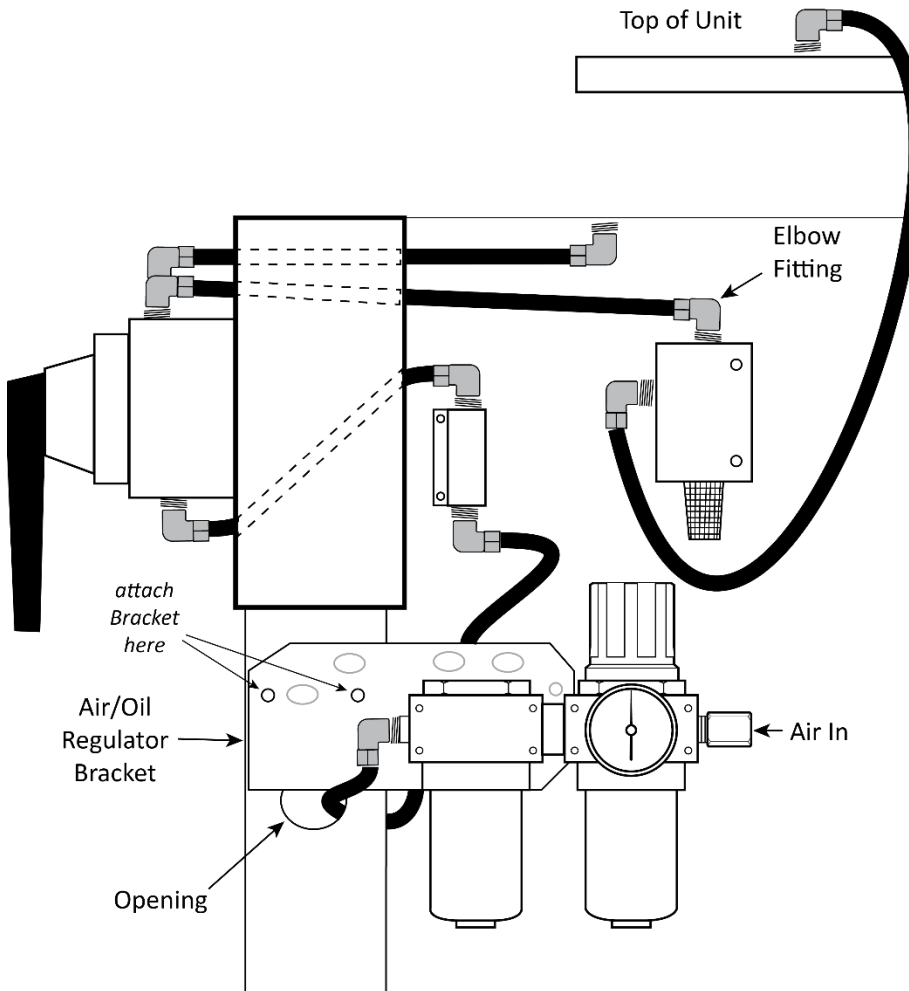

**Note:**  
Drawing shows the side of the Unit.

Not all components are shown. Not drawn to scale.

### To install the Air Lines:

1. Attach the Air/Oil Regulator and Bracket to the Enclosure using two M4 x 42 Screws.
2. Cut a piece of tubing of appropriate lengths for each of the five Air Line segments.
3. Connect the various pieces of tubing to the Straight Fitting and Elbow Fittings, as shown above.  
Make sure to route the Straight Fitting tubing through the opening and behind the Air/Oil Regulator.
4. Securely tighten all the connections.
5. Connect your customer-supplied air pressure to the "Air In", a minimum of 125 – 175 psi.

---

# Operation

This section describes how to use the Oil Filter Crusher safely during normal operation.

## Safety Rules

**Important:** Your safety is dependent on reading, understanding, and implementing these Safety Rules. ***Do not skip over them, read them carefully and follow them.***

### To use your Oil Filter Crusher safely:

- Before crushing an Oil Filter, inspect the unit. Check for worn or missing part, loose connections, or any other abnormalities.
- Only allow trained, supervised personnel to operate the Oil Filter Crusher.
- Do not smoke while using the Oil Filter Crusher.
- Do not try to open the Door while an Oil Filter is being crushed.
- Other than the Technician operating the Oil Filter Crusher, keep all other people a minimum of 30 feet away from the unit while it is being used.
- Only put one Oil Filter in the Crusher at a time.
- Avoid off-center loads. If the press ram seems to be laboring more than usual or the filter/can is unusually hard to press, stop operation. Do not operate the press ram if the filter/can tilts or binds during the downward movement of the press head.
- Do not leave the Oil Filter Crusher with the Press Ram down; always complete the crushing cycle.
- ***Pay attention at all times while using the Oil Filter Crusher. Safety is your top priority at all times.***

### To operate your oil filter crusher:

1. Connect the air supply to the Air Fitting and turn the air supply on, a minimum of 125 – 175 psi.
2. Place an approved waste oil container under the oil drain (on the underside of the Enclosure Base).
3. Open the Door and place an empty filter or paint can in the center of the chamber, *open end down*.
4. Close and lock the Door.

 **CAUTION** You cannot crush an item until the sliding door is fully closed.

5. To begin operation, turn the Control Handle to the ***Left***.

 **WARNING** Once the Press Ram makes contact with the item, step away as far as possible until the procedure is complete.

6. To remove the crushed filter, turn the Control Handle to the ***Right***.

The air will exhaust from the press cylinder and the Press Ram will rise.

 **WARNING** Do not open the door while the unit is operating; you must wait for the press to cycle completely.

***Do not get distracted when removing a crushed filter. Be very careful not to scratch, cut, or puncture your skin on the sharp edges of the crushed filter. Watch for leaking oil.***

7. Place the Control Handle in “Off” (middle) position when the unit is not in use.

**⚠ WARNING** Do not leave the Press Ram in the loaded position (pressed down). Once the Oil Filter has been crushed, immediately retract the Press Ram, and then switch the Control Handle to the “Off” position

## Maintenance

**⚠ WARNING:** Disconnect the unit from its power source ***before performing any maintenance!***

### To maintain your oil filter crusher:

- Make sure to keep the press clean and free of debris and dirt.
- All exposed machine surfaces of the press should be brushed clean and wiped with a lubricant, such as WD-40® for example, on a regular basis.
- Regularly check the air lubricator and water filter for water and drain as needed.
- Regularly clean the press chamber to remove any accumulated sludge, metal particles, or other debris that could affect operation.
- Keep the oil drain (on underside of reservoir base) free of accumulation of debris; remove any materials that may be clogging the oil drain.
- Inspect for leaks and drain the approved waste oil container in accordance with all local, state, and federal regulations.
- Lubricate the sliding door on a regular basis to prevent the door from binding.

## Troubleshooting

<b>Issue</b>	<b>Action to Take</b>
Press ram does not move when turned to the On position.	Check the Air Line connections.
Cycle stops before completing.	Check to see if the item being crushed is stuck; if so, remove the item and start again.  Check to see if the item being crushed is off center. If so, balance the load and start again.

If you continue to have issues with your Oil Filter Crusher, visit [BendPak Support](#), email us at [support@bendpak.com](mailto:support@bendpak.com), or call **(805) 933-9970**.

# Labels

A

**R Ranger.**

**Oil Filter/Can Crusher**

**RP-20FC**

**10 TON CAPACITY**

- ✓ 10 Ton Pressure: 20,000 lbs. (9072 kg.)
- ✓ Cycle Time: 20 seconds
- ✓ Chamber: 11 x 8 x 11 (279 x 203 x 279)
- ✓ Air Supply: 125-175 psi

**⚠ WARNING**

**IMPORTANT SAFETY INSTRUCTIONS**

Make sure to read and understand all instructions and safety precautions as outlined in the manufacturer's service manual prior to using this equipment. Failure to follow ALL instructions can result in death or bodily harm to operator and/or bystanders.

- ✓ Never exceed the recommended 125 to 175 PSI working pressure.
- ✓ Always wear ANSI-approved safety goggles, eye protection.
- ✓ Do not involve other people when operating this unit and do not operate this unit when someone else in the vicinity is working.
- ✓ Do not operate the press in explosive atmospheres, such as in the presence of flammable liquids, gases, or dust.
- ✓ Do not attempt to crush aerosol cans, cylinders of compressed gas, fuel lines, or containers of flammable liquids or solvents.
- ✓ Do not touch metal or wires inside the crushing chamber.
- ✓ Never attempt to service this unit while it is connected to its air supply source.

**OPERATION**

1. **WARNING** - Prior to operation a visual inspection shall be made. Check press for leaks, worn or missing parts. Any press that appears to be damaged in any way, is badly worn, or operates abnormally must be removed from use until repairs are made. Contact a factory authorized service center for repair or maintenance of the press.
2. Connect air supply to the air connection fitting. Turn the external air supply on.
3. Open the chamber door and place empty filter or can in the center of chamber with the open end down.
4. Close the door and latch it firmly. **Important Note:** The door must be closed and latched, to activate control valve.
5. Position the rock on the control valve to the left (clockwise) to begin press operation.
6. **WARNING** - DO NOT open the door while the unit is operating. Always wait for the press to cycle completely.
7. The press head will descend to crush the filter/can.
8. Once contact between the press head and the filter/can has been made, step away as far as possible and continue to slowly apply pressure until the procedure is complete.
9. **WARNING** - Avoid off-center loads. If the press seems to be laboring more than usual or the filter/can is unusually hard to press, immediately stop operation. Disconnect the press from its air supply source, and inspect to adjust its fit/clearance to allow for an off-center loading condition. Do not operate the press if the filter/can fits or binds during the down movement of the press head.
10. **WARNING** - Never leave the press in a loaded, standing-down condition. Once the crushing job has been completed, immediately retract the press head then switch the operation lever on the valve body to the retraction position.
11. To remove the crushed material, push on the knob on the control valve to the right (counterclockwise). The air will exhaust from the press cylinder and the press head will rise.
12. Open the door to remove the filter/can from the press chamber.
13. **WARNING** - Never attempt to remove a filter or can that has become stuck in the moving parts of the press while it is connected to its air supply source.
14. Place the control valve in "OFF" (middle) position when the unit is not in use.

**MAINTENANCE**

- ✓ Keep the press clean and free of debris and dirt.
- ✓ All exposed metal face surfaces of the press should be brushed clean and wiped with WD-40 or equivalent.
- ✓ Regularly check the oil lubricant and motor float for visible drain on rear end.
- ✓ Regularly clean the press chamber to remove any accumulated sludge, metal particles or other debris that could affect the press operation.
- ✓ Apply grease to door hinges on a regular basis to prevent the door from binding.
- ✓ Apply motor oil to door latch pivot points on a regular basis to prevent latch from binding.

1645 Lemonwood Drive • Santa Paula, CA 91366  
TEL: 1-805-533-0970 • www.rangerproducts.com

**ANSI CE**  
P/N 5900010 Made in China

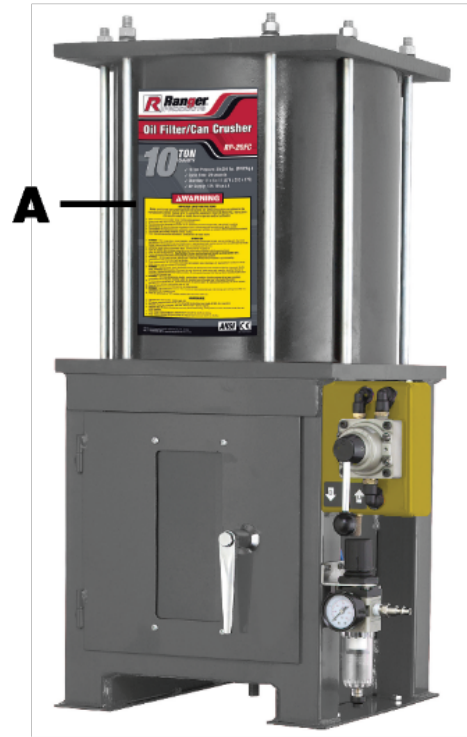

# Parts Diagrams

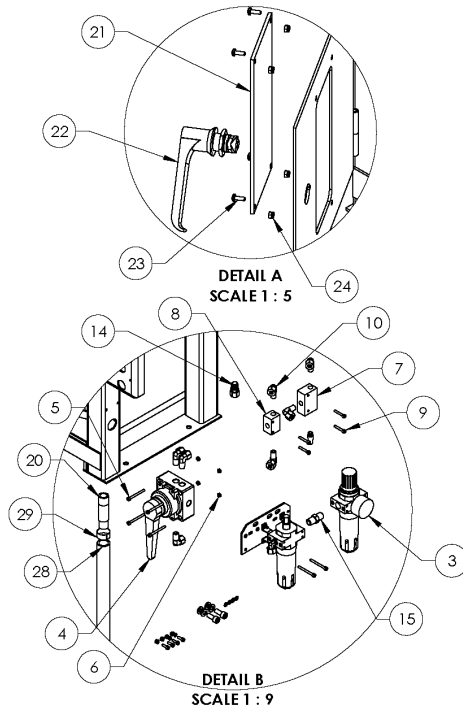
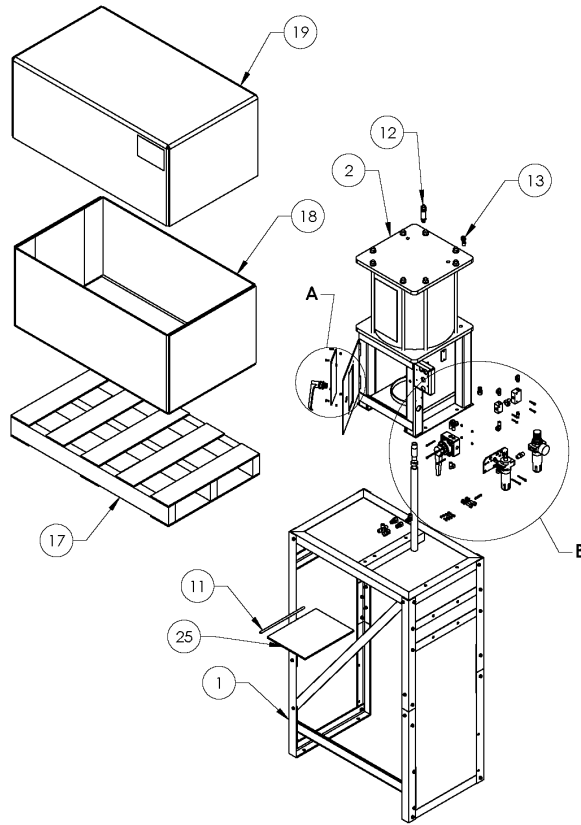

<b>BP BendPak.</b>	
1645 LEMONWOOD DR. SANTA PAULA, CA 93060	
TITLE: RP-20FC ASSEMBLY VER B	
SIZE DWG. NO.	REV
A 5323927	G
SCALE: 1:18	SHEET 2 OF 3

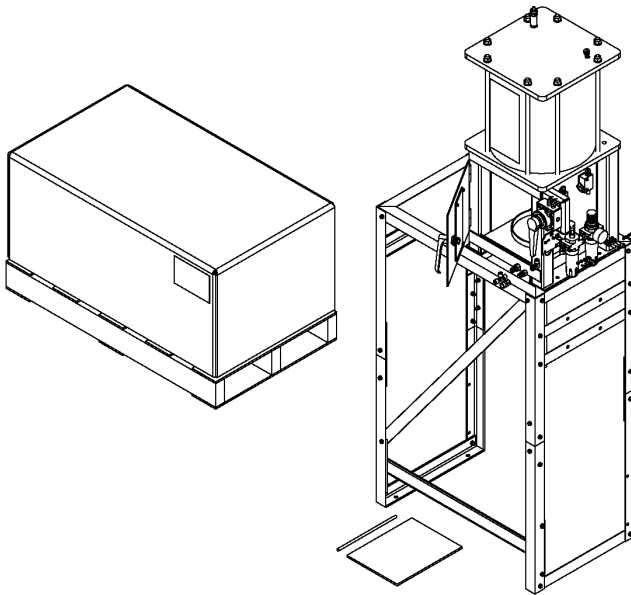

ITEM NO	PART NUMBER	DESCRIPTION	QTY	REV
1	5323977	RP-20FC/30FCH STAND	1	D
2	5323928	RP-20FC WELDMENT	1	E
3	5328220	UNIVERSAL AIR OIL REGULATOR KIT	1	A
4	5325930	CONTROL VALVE ASSEMBLY	1	-
5	5530238	SHCS M4 x 0.7 x 42mm	6	-
6	5535016	NUT M4 X 0.7	4	-
7	5323013	QUICK EXHAUST VENT	1	-
8	5323014	AIR SWITCH	1	-
9	5530052	SHCS M4 x 0.7 x 25mm	4	-
10	5550176	FTG ELB -05 COMP x-02 NPT	7	-
11	5570701	8mm POLY-FLO TUBING	915mm	-
12	5550056	PRESSURE RELIEF VALVE	1	-
13	5550160	FTG ELB -05 COMP x-04 NPT	1	-
14	5550202	FTG NPL -05 COMP x-04 NPT	1	-
15	5550298	FTG NPL -04 NPT x-04 NPT	1	-
16	5550057	1/8" SILENCER	1	-
17	5940029	RP-20FC/30FCH PALLET ASSEMBLY	1	A
18	5781063	RP-20FC/30FCH CARRIER BOX, BOTTOM	1	A
19	5781062	RP-20FC/30FCH CARRIER BOX, TOP	1	A
20	5323364	FILTER CRUSHER DRAIN PIPE FITTING	1	B
21	5325939	FILTER CRUSHER DOOR WINDOW	1	B
22	5580009	L SHAPE HANDLE CAMLOCK	1	-
23	5530020	BHPS M4 x 0.7 x 12	4	-
24	5535010	NUT M4 X 0.7 NL	4	-
25	5900011	RP-20FC INSTALLATION MANUAL	1	B
-	5906019	RP-20FC PRODUCT WARNING DECAL	1	-
-	5906022	RP-20FC CARTON DECAL	1	-
28	5323579	Ø19mm ID x Ø26mm OD x 406mm PVC BRAIDED HOSE	1	A
29	5401716	HOSE CLAMP	1	-

DO NOT SCALE DRAWING		NAME	DATE	<b>BP BendPak.</b> 1645 LEMONWOOD DR. SANTA PAULA, CA 93060	
DRAWN	TS	06/19/2017			
CHECKED	OR	02/08/2021		TITLE: RP-20FC ASSEMBLY VER B	
DIMENSIONS ARE IN MM				SIZE DWG. NO.	REV
THIRD ANGLE PROJECTION				A 5323927	G
				SCALE: 1:14	SHEET 1 OF 3
<small>PROPRIETARY AND CONFIDENTIAL THE INFORMATION CONTAINED IN THIS DRAWING IS THE SOLE PROPERTY OF BENDPAK INC. ANY REPRODUCTION IN WHOLE OR IN PART WITHOUT THE WRITTEN PERMISSION OF BENDPAK INC. IS PROHIBITED.</small>					

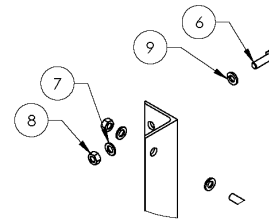
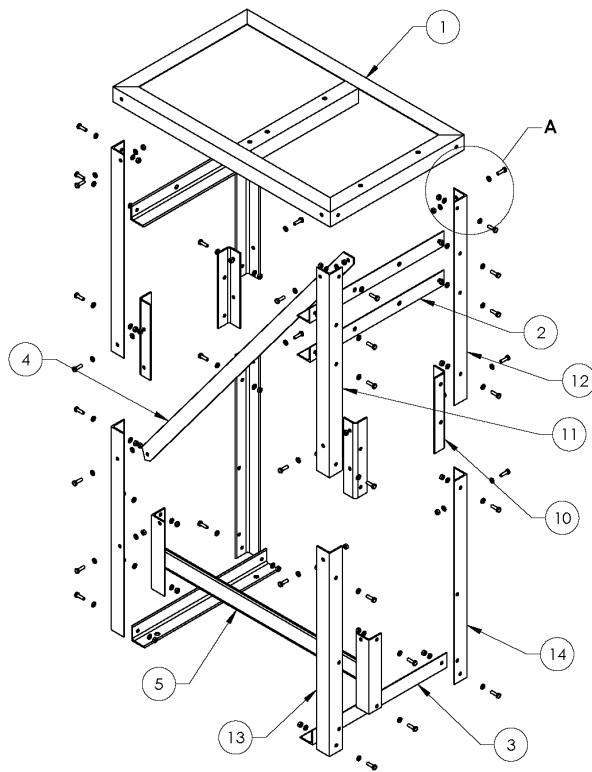

DETAIL A  
SCALE 1 : 4

ITEM NO	PART NUMBER	DESCRIPTION	QTY	REV
1	5323964	RP-20 FCH STAND TOP WELDMENT	1	C
2	5323986	RP-20FC/30FCH STAND MID SHORT	3	C
3	5323974	RP-20FC/30FCH STAND TOP SHORT END	2	B
4	5323993	RP-20FCH STAND DIAGONAL SUPPORT	1	A
5	5323970	RP-20FC/30FCH STAND BOTTOM SUPPORT	1	B
6	5330053	HHB M6 x 1 x 20	39	--
7	5343005	M6 FLAT WASHER	39	--
8	533112	NUT M6 x 1.0	39	--
9	5343026	WASHER M6 x Ø1.2 SL	39	--
10	5323980	RP-20FC/30FCH STAND LEG BRACKET	4	A
11	5323997	RP-20FC/30FCH STAND LONG LEG LH TOP	2	B
12	5323999	RP-20FC/30FCH STAND LONG LEG RH TOP	2	B
13	5323998	RP-20FC/30FCH STAND LONG LEG LH BOTTOM	2	A
14	5323978	RP-20FC/30FCH STAND LONG LEG RH BOTTOM	2	A

DO NOT SCALE DRAWING

DRAWN	TS	03/10/2017
CHECKED	OR	11/02/2020

**BendPak**  
1645 LEMONWOOD DR.  
SANTA PAULA, CA 93060

DIMENSIONS ARE IN MM

THIRD ANGLE PROJECTION

TITLE: RP-20FC/30FCH STAND

SIZE DWG. NO. REV  
A 5323977 D

SCALE: 1:10 SHEET 1 OF 1

PROPRIETARY AND CONFIDENTIAL  
THE INFORMATION CONTAINED IN THIS DRAWING IS THE SOLE PROPERTY OF BENDPAK INC. ANY REPRODUCTION IN WHOLE OR IN PART WITHOUT THE WRITTEN PERMISSION OF BENDPAK INC. IS PROHIBITED.

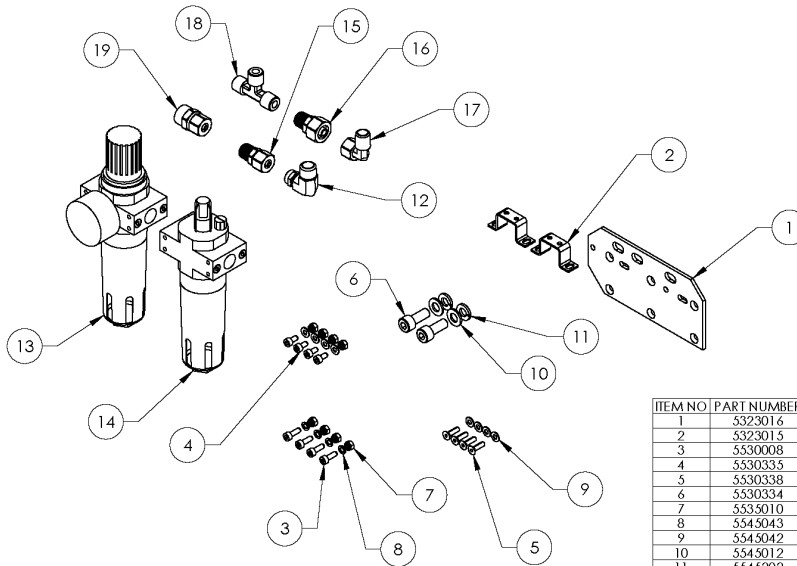

ITEM NO	PART NUMBER	DESCRIPTION	QTY	REV
1	5323016	AIR OIL/REGULATOR MOUNTING PLATE	1	A
2	5323015	AIR OIL/REGULATOR MOUNTING BRACKET	2	A
3	5330008	SHCS M4 x 0.7 x 12 BOC	4	--
4	5330335	SHCS M4 x 0.7 x 8 ZPL	4	--
5	5330338	FHCS M4 x 0.7 x 12 ZPL	4	--
6	5330334	SHCS M8 x 1.25 x 12 BOC	2	--
7	5335010	NUT M4 x 0.7 NL	8	--
8	5345043	WASHER M4 x Ø7.6 SL	4	--
9	5345042	WASHER M4 x 0.7 FLAT	8	--
10	5345012	WASHER, M8x1.6x1.6mm FLAT	2	--
11	5345202	WASHER M8 x Ø1.5 SL	2	--
12	5350083	FTG ELB -04 COMP x -04 NPT	1	--
13	5327846	FILTER REGULATOR	1	--
14	5327847	OILER/LUBRICATOR	1	--
15	5350202	FTG NPL -05 C COMP x -04 NPT	1	--
16	5350205	FTG NPL -08 C COMP x -04 NPT	1	--
17	5350160	FTG ELB -05 COMP x -04 NPT	1	--
18	5350171	FTG TEE -04 NPT x -04 NPT x -04 NPT	1	--
19	5350204	FTG NPL -05 COMP x -04 F NPT	1	--

DO NOT SCALE DRAWING

DRAWN	TM	07/18/2017
CHECKED	CA	6/11/2018

**BendPak**  
1645 LEMONWOOD DR.  
SANTA PAULA, CA 93060

DIMENSIONS ARE IN MM

THIRD ANGLE PROJECTION

TITLE: UNIVERSAL AIR OIL REGULATOR KIT

SIZE DWG. NO. REV  
A 5328220 A

SCALE: 1:4 SHEET 1 OF 1

PROPRIETARY AND CONFIDENTIAL  
THE INFORMATION CONTAINED IN THIS DRAWING IS THE SOLE PROPERTY OF BENDPAK INC. ANY REPRODUCTION IN WHOLE OR IN PART WITHOUT THE WRITTEN PERMISSION OF BENDPAK INC. IS PROHIBITED.











1645 Lemonwood Drive  
Santa Paula, CA 93060 USA