

GrandPrix Two-Post Lifts Installation and Operation Manual

Manual P/N 5900209 — Manual Revision E2 — September 2022

Models:

- GP-7
- GP-7LC
- GP-7LCS



Model GP-7 shown.

Designed and engineered by BendPak Inc. in Southern California, USA. Made in China

 **DANGER**

IMPORTANT SAFETY INSTRUCTIONS, SAVE THESE INSTRUCTIONS! Read this manual thoroughly before installing, operating, servicing or maintaining this Lift. Failure to follow the instructions and safety precautions in this manual can result in serious injury or death. Make sure all other operators also read this manual. Keep the manual near the product for future reference. **By proceeding with installation and operation, you agree that you fully understand the contents of this manual and assume full responsibility for product use.**

Manual. GrandPrix Series Two-Post Lifts, *Installation and Operation Manual*, Manual P/N 5900209, Manual Revision E2, released September 2022.

Copyright. Copyright © 2022 by BendPak Inc. All rights reserved. You may make copies of this document if you agree that: you will give full attribution to BendPak Inc., you will not make changes to the content, you do not gain any rights to this content, and you will not use the copies for commercial purposes.

Trademarks. BendPak and the BendPak logo are registered trademarks of BendPak Inc. The GrandPrix logo is a trademark of BendPak Inc. All other company, product, and service names are used for identification only. All trademarks and registered trademarks mentioned in this manual are the property of their respective owners.

Limitations. Every effort has been made to ensure complete and accurate instructions are included in this manual. However, product updates, revisions, and/or changes may have occurred since this manual was published. BendPak reserves the right to change any information in this manual without incurring any obligation for equipment previously or subsequently sold. BendPak is not responsible for typographical errors in this manual. You can always find the latest version of the [manual for your product on the GrandPrix website](#).

Warranty. The BendPak warranty is more than a commitment to you: it is also a commitment to the value of your new product. Contact your nearest BendPak dealer or visit www.bendpak.com/support for full warranty details.

Safety. Your new product was designed and manufactured with safety in mind. Your safety also depends on proper training and thoughtful operation. Do not set up, operate, maintain, or repair the unit without reading and understanding this manual and the labels on the unit; **do not use your Lift unless you can do so safely.**

Owner Responsibility. In order to maintain your product properly and to ensure operator safety, it is the responsibility of the product owner to read and follow these instructions:

- Follow all installation, operation, and maintenance instructions.
- Make sure product installation conforms to all applicable local, state, and federal codes, rules, and regulations, such as state and federal OSHA regulations, building and electrical codes.
- Read and follow all safety instructions. Keep them readily available for operators.
- Make sure all operators are properly trained, know how to safely operate the unit, and are properly supervised.
- Do not operate the product until you are certain that all parts are in place and operating correctly.
- Carefully inspect the product on a regular basis and perform all maintenance as required.
- Service and maintain the unit only with approved replacement parts.
- Keep the manual with the product and make sure all labels are clean and visible.
- **Only use the Lift if it can be used safely!**

Unit Information. Enter the Model Number, Serial Number, and the Date of Manufacture from the label on your unit. This information is required for part or warranty issues.

Model: _____

Serial: _____

Date of Manufacture: _____

Table of Contents

Introduction	3	Operation	50
Shipping Information	4	Maintenance	55
Safety Considerations	4	Troubleshooting	57
FAQ	7	Wiring Diagrams	59
Specifications	8	Parts Drawings	60
Components	9	Labels	70
Installation Checklist	11	Maintenance Logs	74
Installation	12		

Introduction

This manual describes the GrandPrix (GP-7 Series) two-post Lifts from BendPak:

- **GP-7.** Two-post Lift, 7,000 lb. capacity, 74 inch rise, requires a 13-foot ceiling.
- **GP-7LC.** Two-post Lift, 7,000 lb. capacity, 64 inch rise, needs only a 10-foot ceiling.
- **GP-7LCS.** Two-post Lift, 7,000 lb. capacity, 54 inch rise, needs only a 9-foot ceiling.

All three models of the GrandPrix are **ALI certified**.

More information about the full line of BendPak products is available at bendpak.com.

This manual is mandatory reading for all users of GP-7 Series Lifts, including anyone who installs, operates, maintains, or repairs them.

⚠ DANGER Be very careful when installing, operating, maintaining, or repairing this equipment; failure to do so could result in property damage, product damage, injury, or (in very rare cases) death. Make sure only authorized personnel operate this equipment. All repairs must be performed by an authorized technician. Do not make modifications to the unit; this voids the warranty and increases the chances of injury or property damage. Make sure to read and follow the instructions on the labels on the unit.

Keep this manual on or near the equipment so that anyone who uses or services it can read it.

If you are having issues, refer to the **Troubleshooting** section of this manual for assistance.

Technical support and service is available from your dealer, on the Web at bendpak.com/support, by email at support@bendpak.com, or by phone at **(800) 253-2363**, extension 196.

You may also contact BendPak for parts replacement information (please have the model and serial number of your unit available) at **(800) 253-2363**, extension 191.

Shipping Information

Your equipment was carefully checked before shipping. Nevertheless, you should thoroughly inspect the shipment **before** you sign to acknowledge that you received it.

When you sign the bill of lading, it tells the carrier that the items on the invoice were received in good condition. **Do not sign the bill of lading until after you have inspected the shipment.** If any of the items listed on the bill of lading are missing or damaged, do not accept the shipment until the carrier makes a notation on the bill of lading that lists the missing or damaged goods.

If you discover missing or damaged goods **after** you receive the shipment and have signed the bill of lading, notify the carrier at once and request the carrier to make an inspection. If the carrier will not make an inspection, prepare a signed statement to the effect that you have notified the carrier (on a specific date) and that the carrier has failed to comply with your request.

It is difficult to collect for loss or damage after you have given the carrier a signed bill of lading. If this happens to you, file a claim with the carrier promptly. Support your claim with copies of the bill of lading, freight bill, invoice, and photographs, if available. Our willingness to assist in helping you process your claim does not make us responsible for collection of claims or replacement of lost or damaged materials.

Safety Considerations

Read this manual carefully before using your new product. Do not install, operate or service the product until you are familiar with all operating instructions and warnings. Do not allow anyone else to operate the product until they are also familiar with all operating instructions and warnings.

SAVE THESE IMPORTANT SAFETY INSTRUCTIONS!





1. Read all instructions.
2. Care must be taken as burns can occur from touching hot parts.
3. Do not operate equipment with a damaged cord or if the equipment has been dropped or damaged – until it has been examined by a qualified service person.
4. Do not let a cord hang over the edge of a table, bench, or counter or come in contact with hot manifolds or moving fan blades.
5. If an extension cord is necessary, a cord with a current rating equal to or more than that of the equipment should be used. Cords with a current rating less than the equipment may overheat. Care should be taken to arrange the cord so that it will not be tripped over or pulled.
6. Always unplug the equipment from the electrical outlet when not in use. Never use the cord to pull the plug from the outlet. Grasp the plug and pull to disconnect.
7. Let the equipment cool completely before putting away. Loop cord loosely around equipment when storing.
8. To reduce the risk of fire, do not operate in the vicinity of open containers of flammable liquids (gasoline).
9. Adequate ventilation should be provided when working on operating internal combustion engines.
10. Keep hair, loose clothing, fingers, and all parts of body away from moving parts.

-
11. To reduce the risk of electric shock, do not use on wet surfaces or expose to rain.
 12. Use only as described in this manual. Use only BendPak recommended attachments.
 13. ALWAYS WEAR SAFETY GLASSES. Everyday eyeglasses only have impact resistant lenses, they are not safety glasses.
 14. To reduce the risk of injury, close supervision is necessary when this product will be used around children.
 15. To reduce the risk of injury, **never** attempt to lift more than the rated capacity. Refer to loading instructions.
 16. The Lift uses electrical energy; if your organization has Lockout/Tagout policies, make sure to implement them after connecting the Lift to a power source.
 17. Refer to markings for proper load on electrical receptacles.
 18. Only operate your Lift between temperatures of 41°F to 104°F (5°C to 40°C).
 19. The Lift should **only** be operated by authorized personnel. Keep children and untrained personnel away from the Lift.
 20. Do not make any modifications to the Lift; this voids the warranty and increases the chances of injury or property damage.
 21. Do not use the Lift while tired or under the influence of drugs, alcohol, or medication.
 22. Consider the work environment. Keep the work area clean. Cluttered work areas invite injuries. Keep areas well lit.
 23. **Always** make sure the Lift is secured on Safety Locks before attempting to work on or near a Vehicle.
 24. Make a thorough inspection of the product at least once a year. Replace any damaged or severely worn parts, decals, or warning labels. Replace worn or damaged parts with BendPak or BendPak approved parts and assemblies only.
 25. BendPak recommends referring to the ANSI/ALI ALIS Standard *Safety Requirements for Installation and Service* for more information about safely installing, using, and servicing your Lift.
 26. You **must** wear OSHA-approved (publication 3151) personal protective equipment at all times when installing, using, maintaining, or repairing the Lift. Leather gloves, steel-toed work boots, eye protection, back belts, and hearing protection are **mandatory**.
 27. Keep loads balanced on the Lift Arms. Clear the area immediately if a Vehicle is in danger of falling off the Lift.
 28. Do not make any modifications to the Lift. Modifications void the warranty and increase the chances of injury or property damage. Do **not** modify any safety-related features in any way.
 29. While handling a Hydraulic Cylinder or a Hydraulic Hose, **always** wear gloves. In rare cases, a needle-like stream of hydraulic fluid (even at low pressure) can penetrate fingers, hands, or arms; such a puncture can feel like a bite, electric shock, or a prick. While it may seem like a minor issue, any amount of Hydraulic Fluid injected into the human body is a serious issue. Anyone suffering such a puncture wound should be **immediately** taken to a hospital emergency room to determine the extent of the injury. Explain the circumstances of the injury to the attending physician, including what kind of Hydraulic Fluid was involved. Do not assume a puncture wound that could have been caused by Hydraulic Fluid is a minor issue; it could be life threatening.

-
30. Make an inspection of the Lift **before** using it. Check for damaged, worn, or missing parts. Do not use it if you find any of these issues. Instead, take it out of service, then contact an authorized repair facility, your dealer, or BendPak at **(877) 432-6627** or support@BendPak.com.
 31. GP-7 Series Lifts are two-post Lifts. **Use them only for their intended purpose**. If you are looking for a *parking* Lift, visit the [Bendpak website](#).
 32. Do not use the product while tired or under the influence of drugs, alcohol, or medication.
 33. Make sure all operators read and understand the *Installation and Operation Manual*. Keep the manual near the device at all times.
 34. Make a visual inspection of the product before using it. Do not use the product if you find any missing or damaged parts. Instead, contact an authorized repair facility, your distributor, or BendPak at (805) 933-9970 or support@bendpak.com.
 35. BendPak recommends making a *thorough* inspection of the product at least once a year. Replace any damaged or severely worn parts, decals, or warning labels.
 36. Use only BendPak Inc. or BendPak approved replacement parts.

Symbols

Following are the symbols used in this manual:

-  **DANGER** Calls attention to a hazard that **will** result in death or injury.
-  **WARNING** Calls attention to a hazard or unsafe practice that **could** result in death or injury.
-  **CAUTION** Calls attention to a hazard or unsafe practice that could result in personal injury, product damage, or property damage.
- NOTICE** Calls attention to a situation that could result in product or property damage.
-  **Tip** Calls attention to information that can help you use your unit better.

Liability Information

BendPak assumes **no** liability for damages resulting from:

- Use of the equipment for purposes other than those described in this manual.
- Modifications to the equipment without prior, written permission from BendPak Inc.
- Injury or death caused by modifying, disabling, overriding, or removing safety features.
- Damage to the equipment from external influences.
- Incorrect operation of the equipment.

-  **WARNING** **California Proposition 65**. This product can expose you to chemicals including styrene and vinyl chloride which are on the list of over 900 chemicals identified by the State of California to cause cancer, birth defects or reproductive harm. **ALWAYS** use this product in accordance with BendPak BendPak's instructions. For more information go to www.P65Warnings.ca.gov.

Frequently Asked Questions

Question: What kinds of Vehicles can I Lift on my GP-7 Series Lift?

Answer: Cars, light trucks, and SUVs; up to 7,000 lbs. (3,175 kg) each.

Q: How long will it take to raise or lower my Vehicle?

A: About 45 seconds, depending on what locking position you use.

Q: Does the Lift have to be anchored in place?

A: Yes. Two-post Lift posts **must** be anchored. Your Lift comes with high-quality Anchor Bolts; use only the Anchor Bolts that came with your Lift.

Q: How thick does my concrete have to be?

A: Concrete specifications are: 4.25 inches thick, 3,000 PSI, cured for a minimum of 28 days. Do not install the Lift on cracked or defective Concrete. Anchor Bolts must be at least 6 inches from cracks, expansion seams, or other inconsistencies in the Concrete. **Do not install the Lift on asphalt or any surface other than Concrete.**

Q: Can I install my Lift outside?

A: No. GrandPrix Lifts are approved for **indoor installation and use only**. Outdoor installation is prohibited.

Q: Which end is the front of the Lift?

A: To determine the front of your Lift, drive a Vehicle in straight and stop. The front of the Vehicle is where the front of the Lift is.

Q: How long can I leave a Vehicle up?

A: As long as you want, **as long as the Lift is engaged on a Safety Lock**. Once a Safety Lock is engaged, gravity holds the Lift in position, so a loss of power has no effect; your Vehicle is going to stay where you left it. Always leave your Lift either fully lowered or engaged on a Safety Lock.

Q: How many Safety Lock positions does my Lift have?

A: Eleven, spaced every 4 inches / 101.5 mm.

Q: Does the Lift have a Front and Rear?

A: Yes and no. Because you can drive onto a two-post Lift from either opening, there is technically no Front and Rear. However, most garages have an Approach side and a Wall side, so in that case, the Wall side is the Front and the Approach side is the Rear.

Q: How do I know where to put the Adapters when I want to raise a Vehicle?

A: The Vehicle needs to be balanced, so you must put the Adapters (sometimes called Pads) so that they contact the manufacturer's recommended Lifting Points. **If you do not know where the manufacturer's recommended Lifting Points are on a Vehicle, you must find out before you raise it.** Your Lift came with books that will help: *Vehicle Lifting Points for Frame Engaging Lifts* shows the Lifting Points for hundreds of Vehicles. *Lifting It Right* includes information about how to raise Vehicles correctly.

Specifications

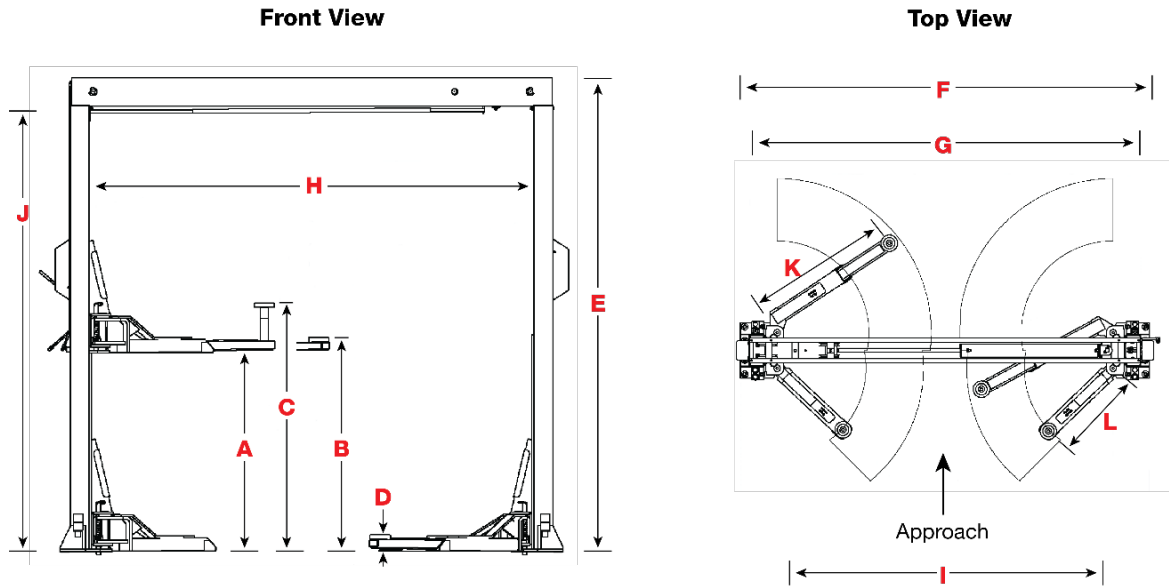

Model	GP-7LCS	GP-7LC	GP-7
Lifting capacity	7,000 lbs. (3,175 kg)		
A – Rise	54in. (1,372 mm)	64 in. (1,626 mm)	74 in. (1,880 mm)
B – Rise + pad	58 in. (1,473 mm)	68 in. (1,727 mm)	78 in. (1,981 mm)
C – Rise + pad + adapter	66 in. (1,676 mm)	76 in. (1,930 mm)	86.5 in. (2,197 mm)
D - Minimum pad height	4.5 in. (114 mm)		
E – Height overall	106.5 in. (2,705 mm)	118.5 in. (3,010 mm)	150 in. (3,810 mm)
F – Width overall	124.75 in. (3,168 mm)		
G - Outside posts	119.5 in. (3,035 mm)		
H – Inside posts	110 in. (2,794 mm)		
I - Drive-thru width	98.25 in. (2,497 mm)		
J - Floor to Trip Stop Tube	96 in. (2,438 mm)	108 in. (2,743 mm)	140 in. (3,556 mm)
K – Front Arm Reach	28 – 47 in. (711 mm – 1,194 mm)		
L – Rear Arm Reach	27 – 43.5 in. (688 mm – 1,111 mm)		
Standard Motor	220 VAC, 60 Hz, 1Ph		
Time to full rise	≈45 seconds		
Maximum operating hydraulic pressure	2,300 PSI		
Sound	≈70 dB		

Specifications subject to change without notice.

Components

GP-7 Series Lift components include:

- **Powerside Post.** The Powerside Post holds the Power Unit, the Safety Lock Release Handle, the Lowering Handle, and the Power Disconnect Switch. The Powerside Post must go under the Cylinder end of the Top Trough.
- **Offside Post.** The other Post. The Offside Post goes under the Cables end of the Top Trough.
- **Power Unit.** Provides hydraulic power to the Lift. Connects to a 220 VAC power source. Includes the button that raises the Lift and a Hydraulic Fluid reservoir that must be filled **before** use.
- **Safety Locks.** Hold the Lift Arms while they are raised. Multiple Safety Locks let you select the best Lift Arm height for your needs. **Only leave your GP-7 Series Lift fully lowered or engaged on a Safety Lock.**
- **Safety Lock Release Handle.** Releases the Lift from its current Safety Lock. Used as part of the lowering process.
- **Lowering Handle.** Lowers a Vehicle from a raised position when used with the Safety Lock Release Handle.
- **Lift Pads.** Rubber pads that contact the Lifting Points of the Vehicles you raise. Also included with your Lift are three sets of extensions (short, medium, tall) that can be used with the Lift Pads.
- **Lift Arms.** Extendable steel arms that attach to the Lift Heads. Lift Arms hold the Lift Pads; after a Vehicle is moved into place, the Lift Arms are moved so that the rubber pads contact the Lifting points on the Vehicle. The Lift Arms are one of the components that actually holds a Vehicle up.
- **Lift Heads.** Sometimes called carriages. Lift Heads move up and down in the Posts. They connect to the Lift Arms, so when the Lift Heads move up, the Lift Arms (and anything on them) also move up, thus raising the Vehicle.
- **Top Trough.** The beam across the top of the Lift; it supports the Lift's structure and holds the Hydraulic Cylinder and the Lifting Cables.
- **Trip Stop Tube.** Located on the underside of the Top Trough, the Trip Stop Tube stops upward movement of the Lift. If you are raising a Vehicle and it hits the Trip Stop Tube, the Lift immediately stops moving up.
- **Power Disconnect Switch.** To be supplied and installed by a licensed Electrician. Immediately interrupts main electrical power to the Lift. Used for electrical circuit faults, emergency situations, or when Lift is undergoing service or maintenance.
- **Thermal Disconnect Switch.** To be supplied and installed by a licensed Electrician. Overload device that shuts down the equipment if there is an overload or an overheated motor. *The Lift's motor has no thermal overload protection.*

The following graphic shows the main components of your GrandPrix Lift.

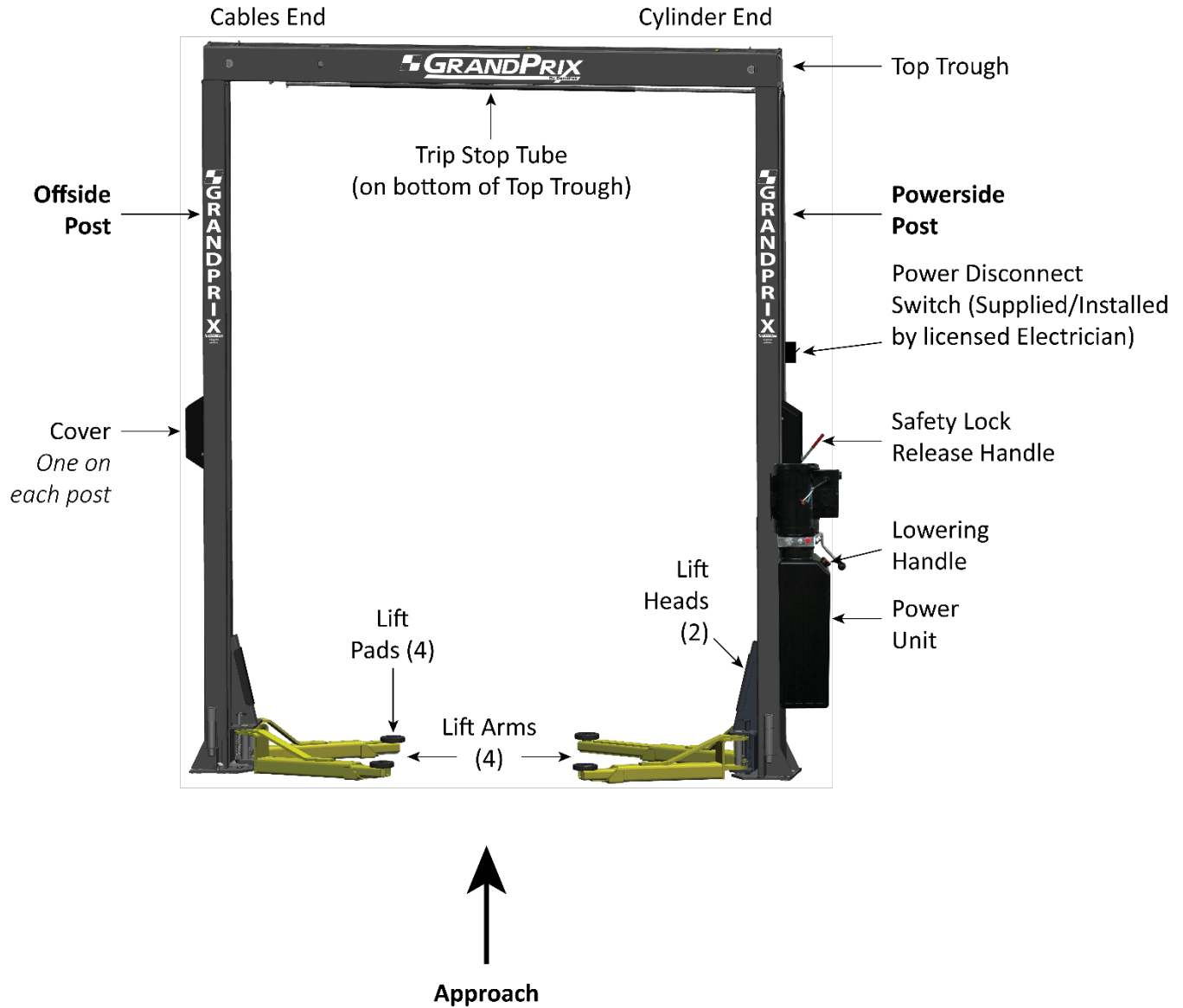

View is from rear of the Lift, looking towards the front. Model GP-7 shown. Not all components shown.

Installation Checklist

Following are the steps needed to install a GP-7 Series Lift; perform them in this order.

- 1. Review the installation Safety Rules.
- 2. Plan for Electrical work.
- 3. Make sure you have the necessary Tools.
- 4. Select the installation Location.
- 5. Check the Clearances.
- 6. Review the installation Orientation.
- 7. Unload and Unpack the Components.
- 8. Install the Post Straps.
- 9. Put down Chalk Line Guides for the Posts.
- 10. About Embedment.
- 11. Install the Posts.
- 12. About the Lifting Cables.
- 13. Prepare the Top Trough.
- 14. Install the Top Trough.
- 15. Install the Power Unit (but do not connect it to power yet).
- 16. Install the Safety Assemblies and the Safety Cable.
- 17. Install the Trip Stop Tube.
- 18. Install the Microswitch.
- 19. About Hydraulic Fluid Contamination.
- 20. About Thread Sealants.
- 21. Install the Hydraulic Line and Return Line.
- 22. Connect the Lifting Cables.
- 23. Install the Safety Covers.
- 24. Install the Lift Arms.
- 25. Contact the Electrician.
- 26. Connect and prepare the Power Unit (Electrician **required**).
- 27. Adding Hydraulic Fluid.
- 28. Install the Power Disconnect Switch and Thermal Disconnect Switch (Electrician **required**).
- 29. Perform final Leveling of the Posts.
- 30. Torque the Anchor Bolts.
- 31. Lubricate the Lift.
- 32. Bleed the Hydraulic Cylinder.
- 33. Perform an Operational Test.
- 34. Review the Final Checklist.

Installation

The installation process includes multiple steps. Perform them in the order listed.

Safety Rules

When installing the Lift, your safety depends on proper training and thoughtful operation.

 **WARNING** Do not install this equipment unless you have automotive Lift installation training. Always use proper Lifting tools, such as a Forklift or Shop Crane, to raise heavy components. Do not install this equipment without reading and understanding this manual and the safety labels on the unit.

Only fully trained personnel should be involved in installing this equipment. Pay attention at all times. Use appropriate tools and Lifting equipment, when needed. Stay clear of moving parts.

 **WARNING** You must wear appropriate protective equipment: leather gloves, non-skid steel-toed work boots, eye protection, back belts, and hearing protection.

Plan Ahead for Electrical Work

You will need to have a licensed, certified Electrician available at some point during the installation. All of the tasks listed below must be performed by an Electrician.

 **DANGER** All wiring *must* be performed by a licensed, certified Electrician. If someone who is not a certified Electrician attempts these tasks, they could damage the Lift or be electrocuted, resulting in serious injury or even death.

The Electrician needs to:

- **Wire the 220 VAC power source to the Power Unit.** This is generally done near the end of the installation process; do not connect the Power Unit at the same time as you install it.
- **Wire the Microswitch to the Power Unit.** This is generally done at the same time as the Electrician wires the power source to the Power Unit, as the Microswitch wiring goes between the incoming power source and the Electrical Box on the Power Unit.
- **Install a Power Disconnect Switch.** A Power Disconnect Switch ensures that the equipment shuts down in the event of an electrical circuit fault or emergency situation. Refer to **Install a Power Disconnect Switch** for more information.
- **Install a Thermal Disconnect Switch.** A Thermal Disconnect Switch ensures that the equipment shuts down in the event of an overload or an overheated motor. Refer to **Install a Thermal Disconnect Switch** for more information.

The Electrician is responsible for providing:

- an appropriate power cable and plug for connecting to the power source
(Wiring to connect the Microswitch to the Power Unit is included)
- a Power Disconnect Switch
- a Thermal Disconnect Switch

Additional information is supplied in the sections describing these tasks.

Tools

You may need some or all of the following tools:

- Rotary hammer drill (or similar)
- ¾ inch carbide bit (conforming to ANSI B212.15)
- Four-foot level, chalk line
- Open-end wrench set, SAE and metric
- Socket and ratchet set, SAE and metric
- Hex key wrench set, torque wrench, crescent and pipe wrenches
- Crowbar, hammer, needle-nose pliers, flat screwdriver
- Tape measure, 25 feet or above
- Forklift, shop crane, heavy-duty rolling dolly
- Two 12-foot ladders, two sawhorses

Selecting a Location

When selecting the location for your GP-7 Series Lift, consider:

- **Architectural plans.** Consult the architectural plans for your desired installation location. Make sure there are no contradictions between what you want to do and what the plans show.
- **Available space.** Make sure there is enough space for the Lift; front, back, sides, and **above**. Refer to **Specifications** section and the **Clearances** section for measurements and requirements.
- **Overhead obstructions.** Check for overhead obstructions such as building supports, heaters, lights, electrical lines, low ceilings, and so on.
- **Power.** You need a 220 VAC power source available for the Power Unit.
- **Outdoor installations.** GrandPrix Lifts are approved for **indoor installation and use only**. *Outdoor installation is prohibited.*
- **Floor.** Only install the Lift on a flat, Concrete floor; do not install on asphalt or any other surface. The surface must be level; do not install if the surface has more than three degrees of slope.

 **WARNING** Installing your Lift on a surface with more than three degrees of slope could lead to injury or even death. Only install GrandPrix Lifts on a level floor (defined as no more than 3/8 of an inch difference over the installation area). If your floor is not level, consider making the floor level or using a different location.

- **Concrete specifications.** Do not install the Lift on cracked or defective concrete. Anchor Bolts must be at least 6 in from cracks, expansion seams, or other inconsistencies in the Concrete. Make sure the concrete is at least 4.25 inches thick, 3,000 PSI, and cured for at least 28 days.

 **CAUTION** BendPak Lifts are supplied with installation instructions and concrete anchors that meet the criteria set by the latest version of the American National Standard “Automotive Lifts – Safety Requirements for Construction, Testing, and Validation”, ANSI/ALI ALCTV. You are responsible for any special regional structural and/or seismic anchoring requirements specified by any other agencies and/or codes such as the Uniform Building Code (UBC) and/or International Building Code (IBC).

Clearances

Clearance around and above the Lift is **required for safety**. Refer to the figures below.

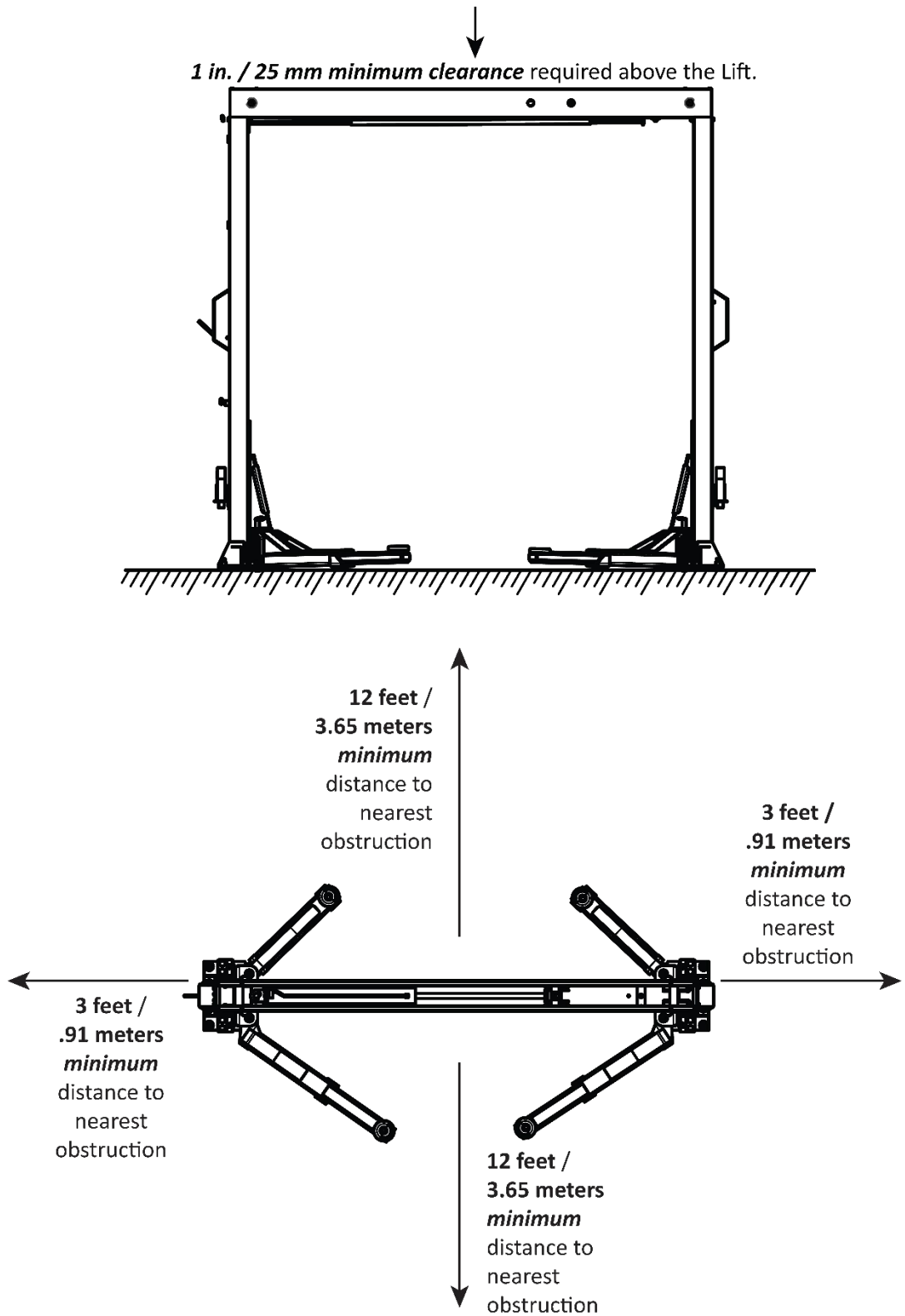

Installation Orientation

To determine the front of your Lift, drive a Vehicle in straight (do not back it in) and stop. **The front of the Lift is where the front of the Vehicle is.**

The orientation of the procedures and drawings in this manual are based on looking at the Lift from the rear, towards the front, unless specified otherwise.

This means that:

- The Powerside Post (which holds the Lowering Handle and the Power Unit) is on the right, the Offside Post is on the left.
- The **Hydraulic Cylinder end** of the Top Trough is on the right, above the Power Unit.
- The two angled arms are at the 'front' of the Lift.
- The two straight arms are at the 'rear' of the Lift.

The following drawing shows how to orient the Powerside and the Offside Posts.

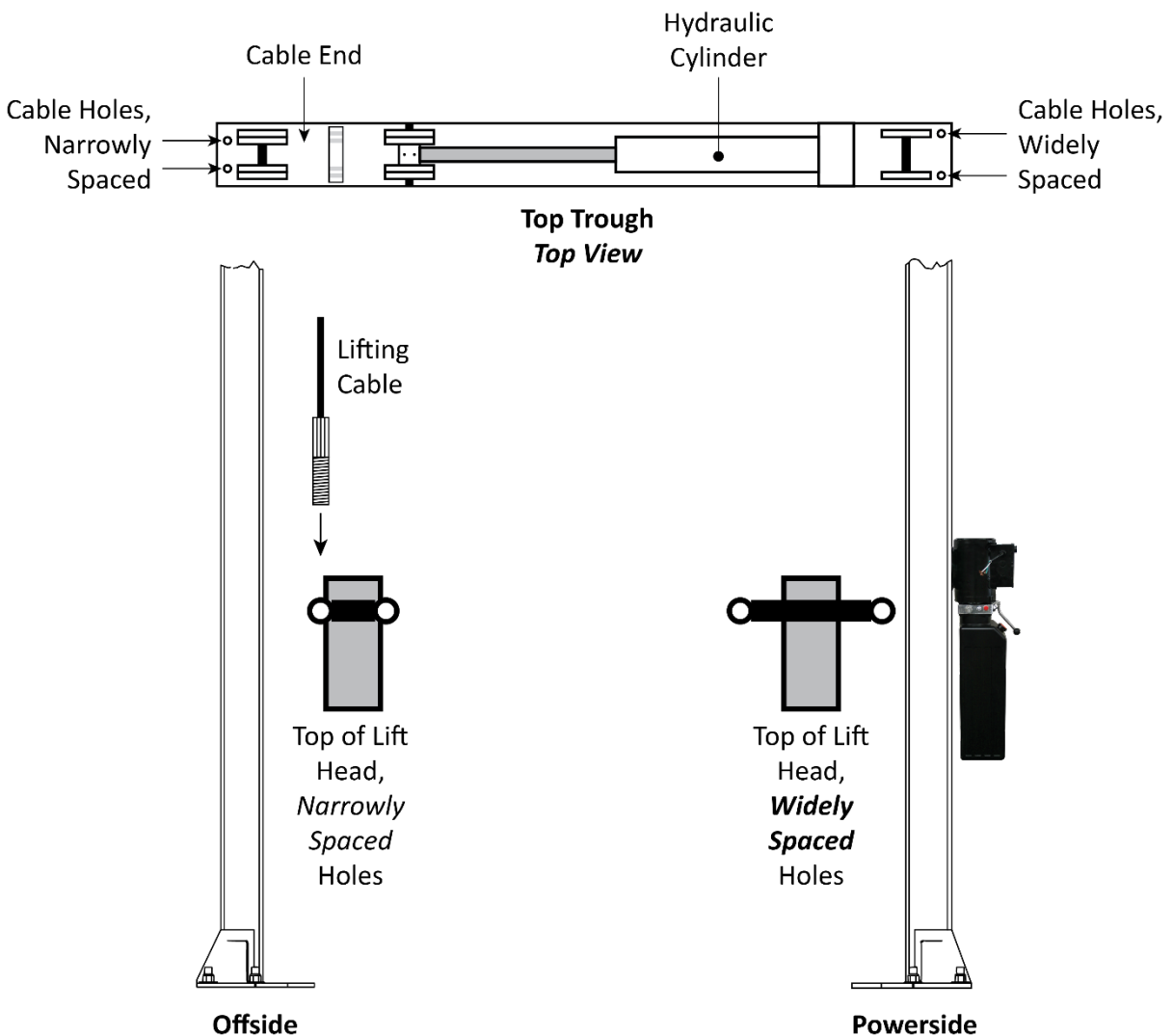

Not to scale. Components removed for clarity.

To identify the Powerside Post and the Offside Post, look at the tops of the Lift Heads in each of the Posts:

- **Powerside Post.** The Lift Head with widely spaced holes is the Powerside Post. The Powerside Post must go under the Cylinder End of the Top Trough.
- **Offside Post.** The Lift Head with the narrowly spaced holes must be the Offside Post. The Offside Post must go under the Cable End of the Top Trough.

Important: You **must** orient the Powerside and Offside Posts this way. If they are set up wrong, the Lift will not work correctly.

Unloading and Unpacking

Since the Lift includes several heavy pieces, you may want to have the Lift unloaded as close to your installation location as delivery allows. Please know that once the Lift and components are unloaded, delivery has ended.

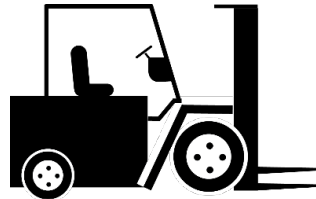

WARNING Some Lift components are very heavy; if handled incorrectly, they can damage materials like tile, sandstone, and brick.

WARNING Many of the Lift components are heavy and awkward to work with. Installation should be accomplished by competent personnel ensuring all heavy components are properly rigged and balanced for lifting. Installation personnel should have knowledge, training, and experience in lifting, rigging, and securing heavy objects.

Installing the Post Straps

You may want to install the Post Straps on their Posts **prior** to standing them up. It is not required, but if you install them after standing up the Posts, you will need a ladder to reach them.

Important: The Post Strap with the **welded plate** goes on the Powerside Post. The Post Strap without the welded plate goes on the Offside Post.

To install the Post Straps:

1. Bolt the Post Strap **with the welded plate** to the Powerside Post.

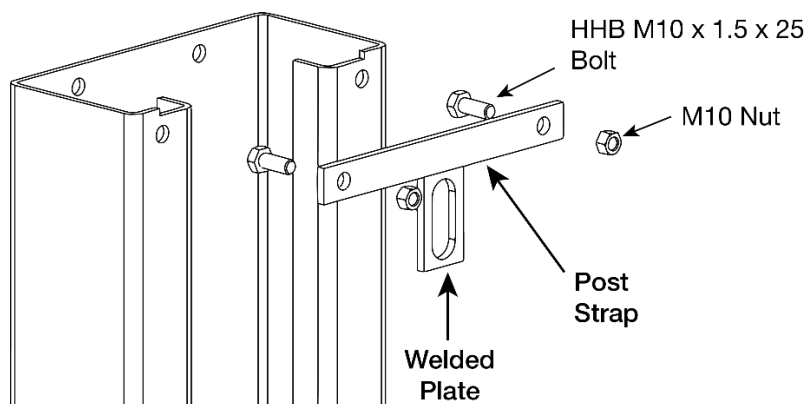

2. Bolt the other Post Strap (no welded plate) to the Offside Post.

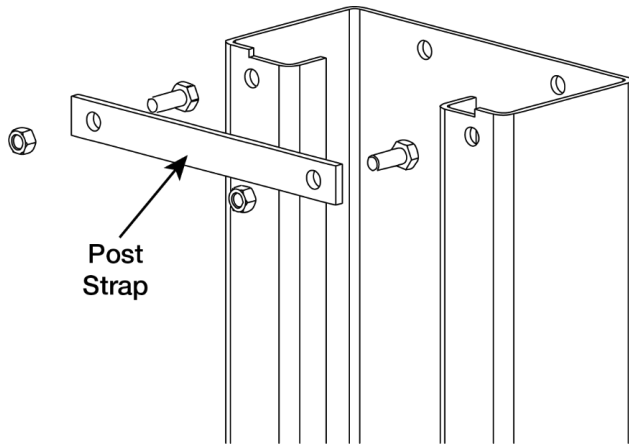

Creating Chalk Line Guides

Based on the specifications for your Lift, create Chalk Line Guides on the ground for the two posts prior to moving them into position.

Use the Width Overall value in **Specifications for your Lift model** to determine where to place the Chalk Line Guides.

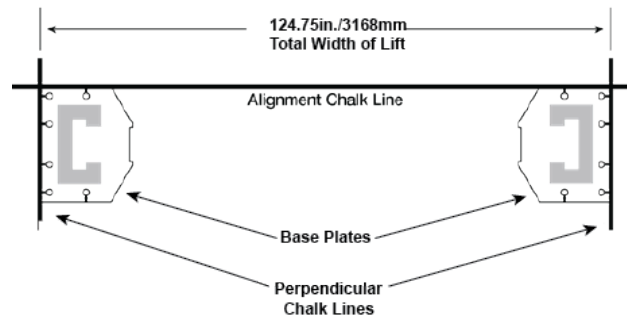

To add Chalk Line Guides:

1. Decide where you want to locate the Lift.

2. Create an alignment chalk line at the desired location.

The Alignment chalk line should be greater than the Width Overall setting for your Lift model.

3. Create two perpendicular chalk lines at 90° angles to the Alignment chalk lines.

The two perpendicular chalk lines must equal **124.75 in. (3,168mm)** distance to each other; otherwise known as the Width Overall setting for your Lift model.

4. When you move the posts into position, place the corners of the base plates into the corners created by the Chalk Line Guides.

About Embedment

Anchor Bolts (also called Wedge Anchors) get their holding strength from how far down into the Hole the Anchor Bolt is installed (called embedment) and how forcefully the Expansion Sleeve presses into the Concrete (based on how much torque is applied).

To get *enough* embedment, you have to understand *Effective* Embedment, which means the location in the Hole where the Expansion Sleeve presses into the Concrete. This is where the Anchor Bolts create holding strength, the further down into the Hole, the greater the holding strength.

(The technical definition of Effective Embedment is the distance from the surface of the base material to the deepest point at which the load is transferred to the base material; the “base material” in our case being the Concrete into which the Anchor Bolts are being installed.)

Some people confuse Effective Embedment with Nominal Embedment, which is how far down into the Hole the bottom of the Anchor Bolt is.

As shown below, the two are not the same. Nominal Embedment is **not** where the load is transferred to the base material, *Effective Embedment* is.

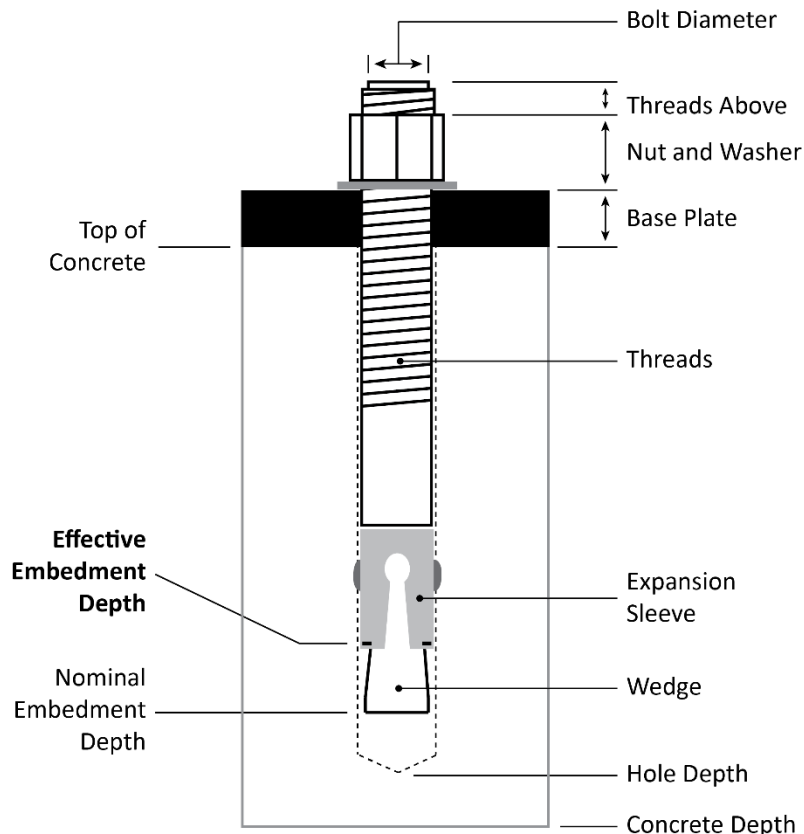

Not necessarily to scale.

The Anchor Bolts shipped with your product have letters stamped into their tops, showing their length.

For example:

- 4.75 in / 120 mm Anchor Bolts are stamped with a **G**.
- 6.3 in / 160 mm Anchor Bolts are stamped with a **J**.

Installing the Posts



Tip Consider **not** tightening the Anchor Bolts into position quite yet. Two reasons: installing the Top Trough and doing final leveling may be easier if there is a little play in the Posts.

Concrete specifications are:

- **Depth:** 4.25 inches / 108 mm thick, minimum
- **Compressive Strength:** 3,000 PSI, minimum
- **Cured:** 28 days, minimum

Anchor Bolt specifications are:

- **Length:** 6.3 inches / 160 mm
- **Diameter:** .75 inch / 19 mm
- **Anchor torque:** 85 – 95 pound feet (never less than 80 or more than 110)
- **Effective embedment:** 3.25 inches / 82.5 mm or more

WARNING

Your Concrete and Anchor Bolts must meet these specifications. Only install your Lift on a Concrete surface. If you install a Lift on asphalt or any other surface, or your Concrete or Anchor bolts do not meet these specifications, it could lead to product damage, Vehicle damage, personal injury, or even loss of life.

BendPak Lifts are supplied with installation instructions and concrete fasteners meeting the criteria as prescribed by the latest version of the American National Standard “Automotive Lifts – Safety Requirements for Construction, Testing, and Validation” ANSI/ALI ALCTV.

WARNING

Use only the ALI-certified Anchor Bolts that came with your Lift. If you use components from a different source, you void your warranty and compromise the safety of everyone who installs or uses the Lift.

Lift buyers are responsible for conforming to all regional, structural, and seismic anchoring requirements specified by any other agencies and/or codes, such as the Uniform Building Code and/or International Building Code.

To install the Posts:

1. Using a Forklift or other appropriate lifting device, move the Posts to the Chalk Line Guides.
2. Stand up each Post, one at a time, and move the appropriate corners into the corners created by the Chalk Line Guides.
3. Double check your measurements against the **Specifications** for your Lift model:
 - Distance from back of one base plate to back of other base plate: **Width Overall** value
 - Distance from inside of one Post to inside of other Post: **Inside Posts** value
4. Using the Base Plates as guides, drill each hole **4 inches / 101 mm** deep.

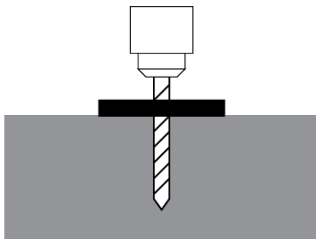

Do not drill all the way through the Concrete; if you punch completely through the slab, you could compromise the holding strength of the Anchor Bolts.

Go in straight; do not let the drill wobble.

Use a carbide bit (conforming to ANSI B212.15).

The diameter of the drill bit must be the same as the diameter of the Anchor Bolt. So, if you are using a $\frac{3}{4}$ inch diameter Anchor Bolt, for example, use a $\frac{3}{4}$ inch diameter drill bit.

5. Vacuum each hole clean.

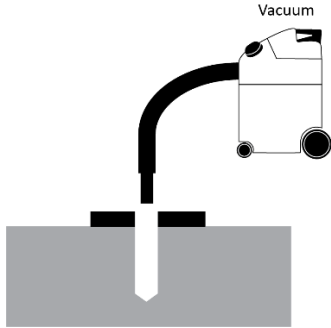

BendPak recommends using a vacuum to get the hole very clean.

You can also use a wire brush, hand pump, or compressed air; just **make sure to thoroughly clean each hole**.

Do **not** ream the hole. Do **not** make the hole any wider than the drill bit made it.

Important: The holding strength of an Anchor Bolt is partially based on the how cleanly the Expansion Sleeve presses against the Concrete. If the hole is dirty or too wide, there is less holding strength.

6. Make sure the Washer and Nut are in place, then insert the Anchor Bolt into the hole.

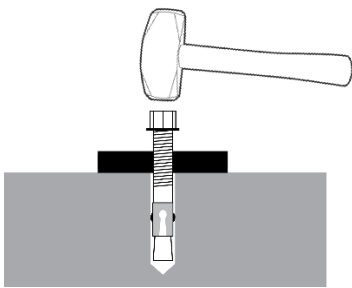

The Expansion Sleeve of the Anchor Bolt may prevent the Anchor Bolt from passing through the hole in the Base Plate; this is normal. Use a hammer or mallet to get the Expansion Sleeve through the Base Plate and into the hole.

Even using a hammer or mallet, the Anchor Bolt should only go into the hole part of the way; *this is normal*. If the Anchor Bolt goes all the way in with little or no resistance, the hole is **too wide**.

Once past the hole in the Base Plate, the Anchor Bolt eventually stops going down into the hole as the Expansion Sleeve contacts the sides of the hole; this is normal.

7. Hammer or mallet the Anchor Bolt the rest of the way down into the hole.
Stop when the Washer is snug against the Base Plate.
8. Plumb each Post; install any needed Shims or the optional Adapter Trays (which let you stack the provided Auxiliary Adapters — also called Extenders — conveniently near the Lift Arms).

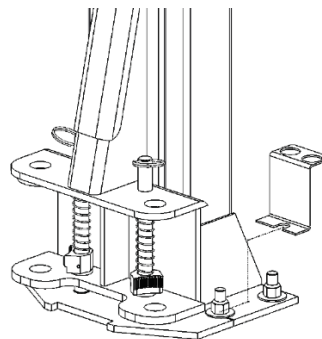
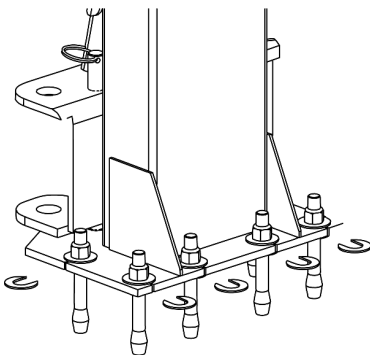

9. **Do not torque the Anchor Bolts at this point.**

Installing the Top Trough and doing final leveling (both of which are done later in the installation process) are both easier if there is a little bit of play in the Posts.

If you torque the Anchor Bolts now, there will not be any play in the Posts, making it more difficult to install the Top Trough and do final leveling.

About the Lifting Cables

⚠ CAUTION We strongly recommend wearing gloves while handling the Lifting Cables.

Your Lift uses four Lifting Cables: two Long Cables and two Short Cables. The following drawing shows the **two different types of ends** on these cables. Note that the ends are exaggerated in this drawing to make it easier to see the two types of ends.



The Button end of all four cables **start** at the same place at the Tie Plate, in the Top Trough.

The Threaded end of the two Short Cables **end** at the Offside Lift Head. The Threaded end of the two Long Cables end at the Powerside Lift Head.

Both short cables are exactly the same; it does not matter what order you install them in. Both long cables are also exactly the same.

The following drawing shows the routing for the Lifting Cables.

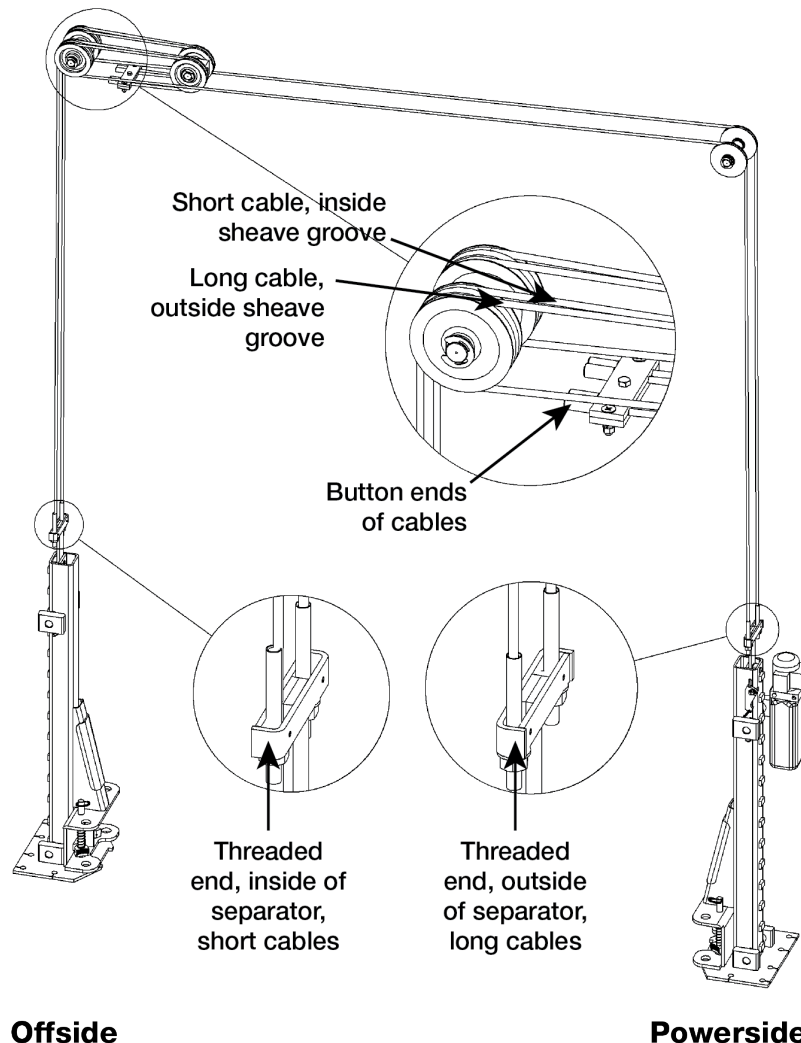

Preparing the Top Trough

The Top Trough goes between the two posts at the top of the Lift.

To prepare the Top Trough, you need to:

- Route the Lifting Cables
- Route the Safety Cables



Tip We **strongly** recommend raising the Top Trough off the ground when performing these preparation tasks; a sawhorse works great for this, for example.

The following drawing is a top view of the components of the Top Trough.

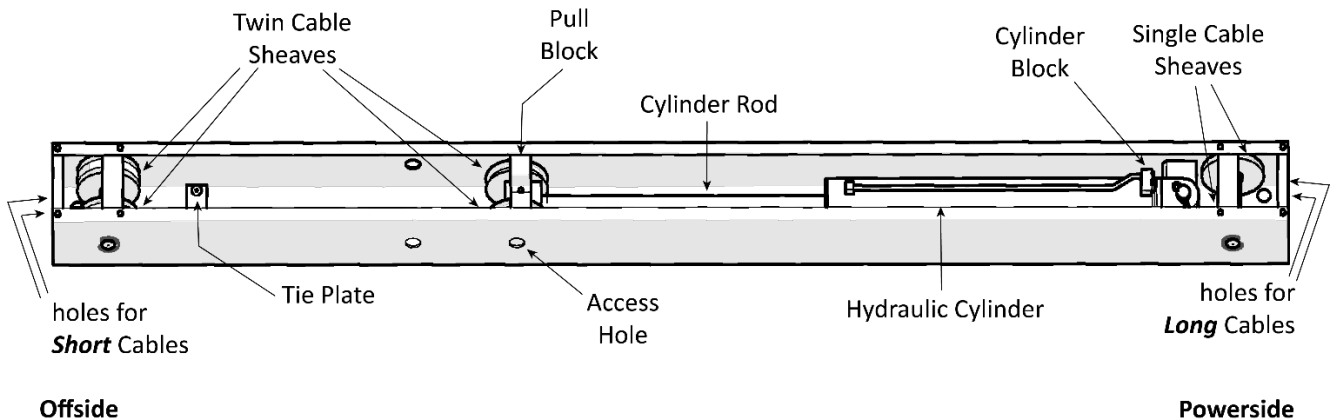

Not all components shown. Tie Plate and holes for Cables not visible from side view of Top Trough.

Routing the Lifting Cables

The Lifting cables move the Lift Heads and Lift Arms up and down.

To route the Lifting cables:

1. Extend the Cylinder Rod until the Pull Block Sheave Pin lines up with the Access Hole; this can be done by carefully pulling the Cylinder Rod by hand or carefully using an air gun.

CAUTION Be careful not to damage the Cylinder Rod when extending it. Do not exceed 50 PSI if using an air gun. If Cylinder Rod is not extending, stop and use a cable puller or other pulling device. Keep hands clear of pinch points.

This drawing is looking down on the Top Trough from above.

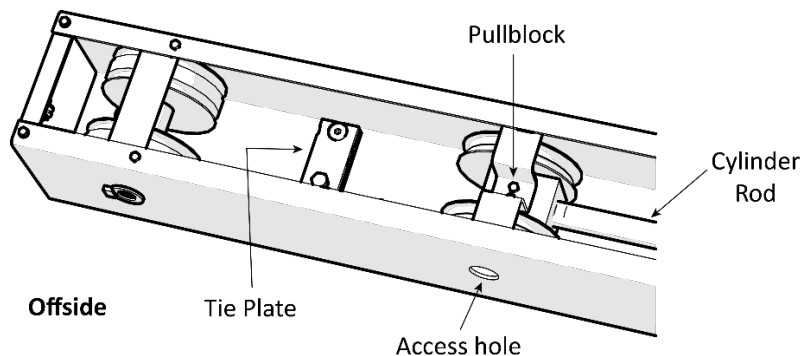



Tip BendPak recommends installing the two Short Cables (which go on the inner sheaves) first, then proceed to the two longer cables (which go on the outer sheaves).

- Put the Button End of first Short Cable into position at the Tie Plate.

The following drawing is a side view of how a Short Cable gets routed over the sheaves.

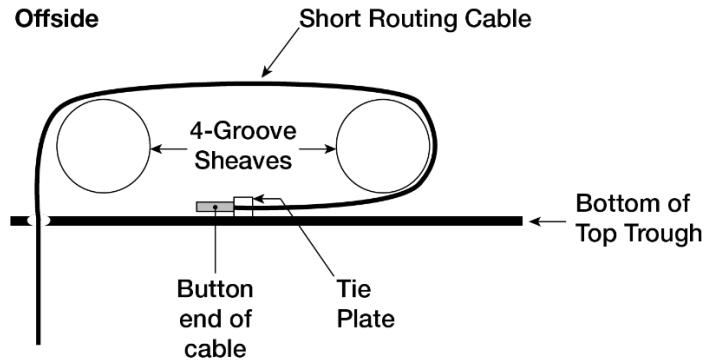

- Route the Short Cable under the bottom of the Cylinder sheave and then over the top of it, over the top of the Offside end sheave, and down through the hole in the bottom of the Top Trough.
- Do the same thing for the second short cable.

Make sure to put the Button End of the second Short Cable on the other side of the Tie Plate from the Button End of the first Short Cable.

- Put the Button End of the first Long Cable into position at the Tie Plate, on the outside of either of the two Short Cables (it does not matter which one you do first).

The following drawing is a side view of how the Long Cables get routed over the sheaves on the Offside end of the Top Trough.

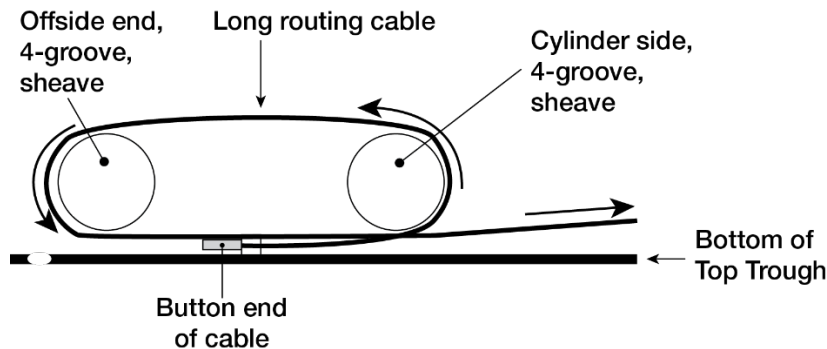

Offside

- Once the Button End is in place, route each Long Cable like this:
 - Under the bottom of the Cylinder side sheave and then over the top of it.
 - Over the top of the Offside end sheave and then under the bottom of it.
 - Past the Cylinder side sheave (without touching it), towards the two-groove sheave on the Powerside end.
 - Over the two-groove sheave on the Powerside end and then down into the appropriate hole in the bottom of the Top Trough.

The following drawing is a side view of how the Long Cables get routed over the two-groove sheave and down into the hole on the Powerside end of the Top Trough.

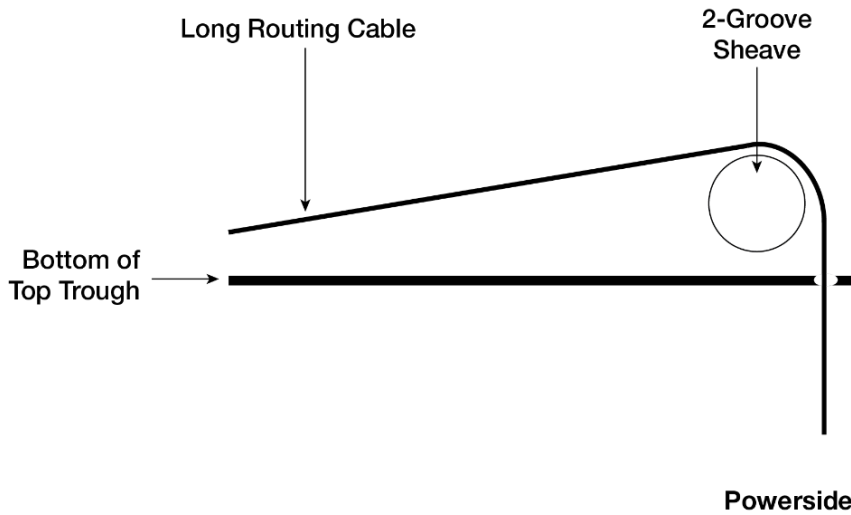

Make sure all cables sit in the grooves and not on either edge of the sheave assembly.

7. Secure the cables with the top of the Tie Plate using a flat head and hex head bolts.

The following drawing shows how the Button ends, and cables should appear just after you secure the top of the Tie Plate into position.

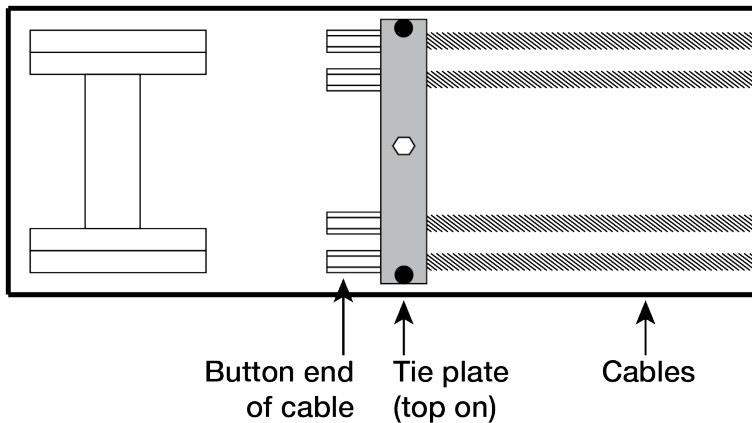

Important: Make sure the cables are carefully aligned in their sheaves; you want to avoid as much contact as possible between the cable and the sheaves while the Lift is in motion. This makes the Lift move more smoothly and extends the life of the cables and the sheaves.

8. The ends of the four cables will be hanging over the ends of the Top Trough.

CAUTION Do not step on or trip over the four Lifting cables while the Top Trough remains near the ground. They are a hazard until the Top Trough is put into position.

Routing the Safety Cable

The Safety Cable connects to the safety mechanism on the Offside Post, goes over the Safety Sheave in the Offside end of the Top Trough, travels over the Lifting Cables in the Top Trough, goes over the Safety Sheave in the Powerside end of the Top Trough, and then goes down to the safety mechanism on the Powerside Post and eventually to the Safety Lock Release Handle.

After being fully set up, the Safety Cable and the Safety Lock Release Handle are used to release the safety locks, allowing the Lift to be lowered.

One end of the Safety Cable has a loop on it, the other does not. The loop end **must** be installed on the **Offside Post** side.

To route the Safety Cable:

1. Locate the Safety Cable.
2. Route the cable through the small notch in the bottom of the Top Trough, around the Offside Safety Sheave, across the Top Trough **above the other components**, around the Powerside Safety Sheave, down through the small notch in the bottom of the Top Trough, and down to the Powerside Safety.

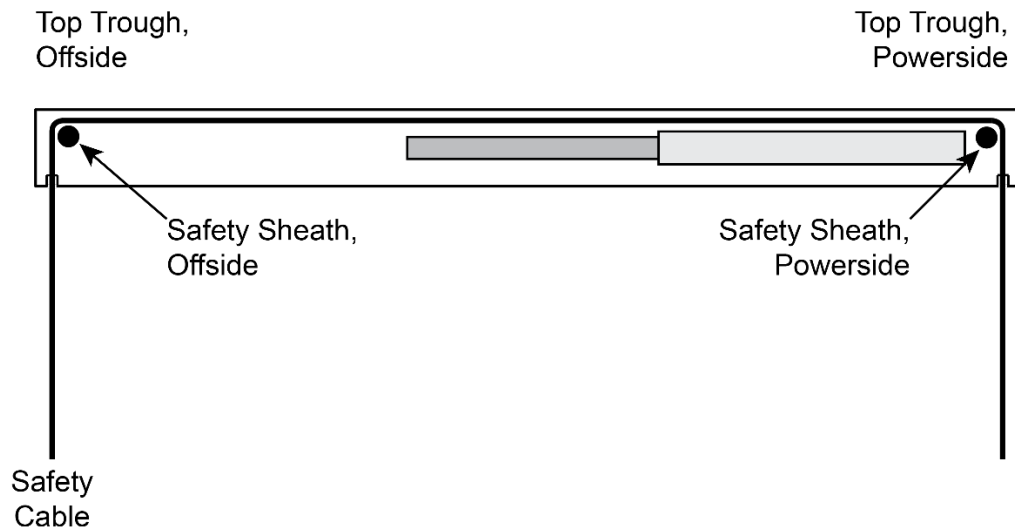

Drawing is a side view, from the Rear looking towards the Front of the Lift. Drawing not to scale, and not all components are shown.

3. Leave the two ends of the Safety Cable hanging over the ends of the Top Trough. They will remain this way until the Top Trough is put into place.

⚠ CAUTION Do not step on or trip over the Safety Cable while the Top Trough remains near the ground. It is a hazard until the Top Trough is put into position.

Installing the Top Trough

The Top Trough holds the Hydraulic Cylinder and the Lifting Cables. It also supports the Trip Stop Tube underneath it.

⚠ CAUTION Watch out for the already-installed cabling. Make sure they do not get in the way as you move the Top Trough into position.

Important: The Top Trough *must* be installed in a specific orientation: the end with the Hydraulic Cylinder *must* go over the Powerside Post; the end with the sheave assemblies *must* go over the Offside Post.

To install the Top Trough:

1. Using a Lifting device, raise the Top Trough into position on top of the two Posts.

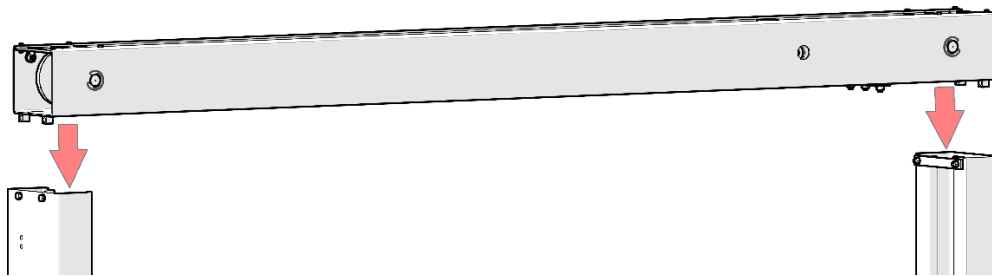

2. Align the holes on the top of the Powerside Post with the holes on the bottom of the Top Trough, then secure the Top Trough in place.

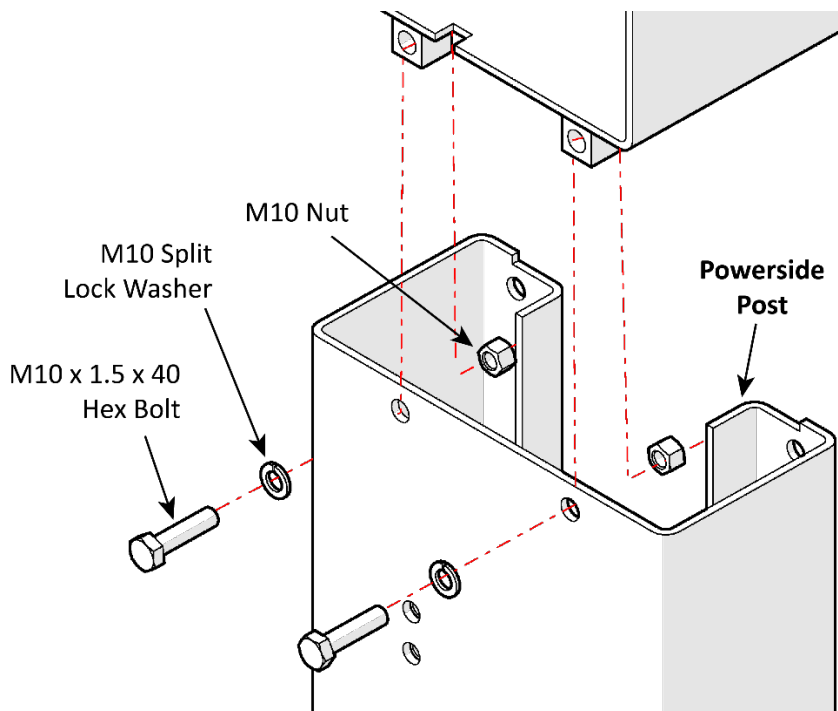

3. Align the holes on the top of the Offside Post with the holes on the bottom of the Top Trough, then connect the two using the supplied 10 mm hex bolts, washers, and nuts.

The Offside Post does not have pipe straps.

Installing the Power Unit

The Power Unit **must** be installed on the Powerside Post.

Important: Do **not** connect the Power Unit to the Hydraulic System or power at this time.

To install the Power Unit:

1. If the Lift Head (also called the carriage) is blocking access on the inside of the Powerside Post to the holes used to attach the Power Unit, raise it out of the way.

WARNING BendPak recommends using a Lifting device to raise the Lift Head; a Forklift, for example. Lift Heads are heavy. If you attempt to raise a Lift Head yourself, you could injure yourself and potentially damage the product.

2. Align the Power Unit mounting holes (in the silver strip on the Power Unit) up with the holes in the Powerside Post, then secure the Power Unit in place.



Tip The Power Unit is heavy; we recommend having one person hold the Power Unit in place while a second person does the bolting.

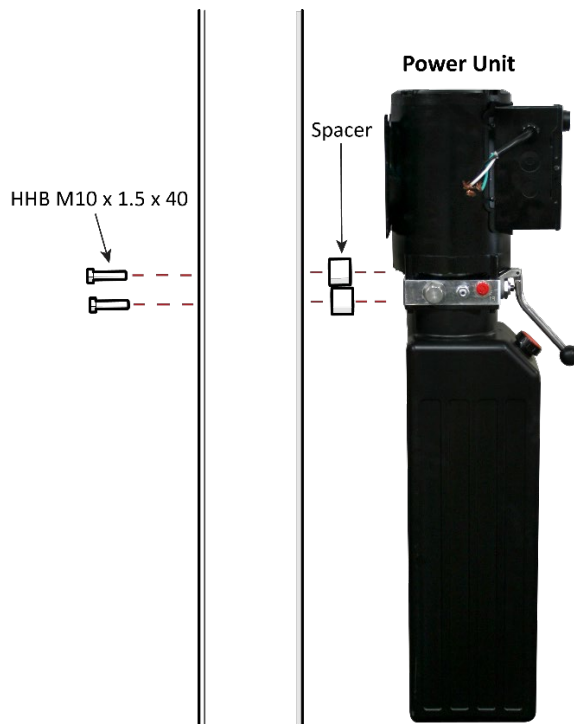

3. Move the Lift Head back down.

Because the Lifting Cables are not in place, the Slack Safeties will engage when you move the Lift Head back down (they are prevented from engaging during normal operation).

Manually hold the Slack Safeties so that they cannot engage as you lower the Lift Head.

Important: You **must** disengage the Slack Safeties before proceeding with the installation.

Installing the Safety Assemblies and the Safety Cable

Each Lift has two Safety Assemblies: one on the Powerside Post and the other on the Offside Post. The two Safety Assemblies work together to take the load off the Hydraulic Cylinder and the Lifting cables once the Lift has reached the desired working height.

The following drawing shows the components of the **Powerside** Safety Assembly.

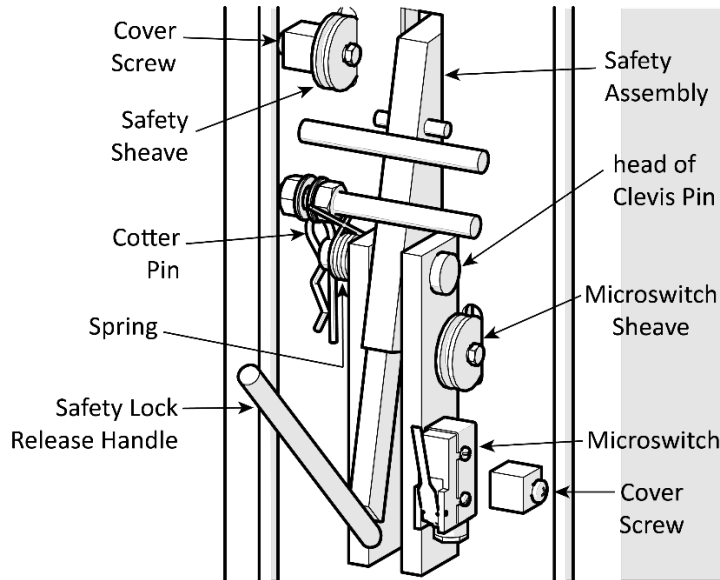

The following drawing shows the components of the **Offside** Safety Assembly.

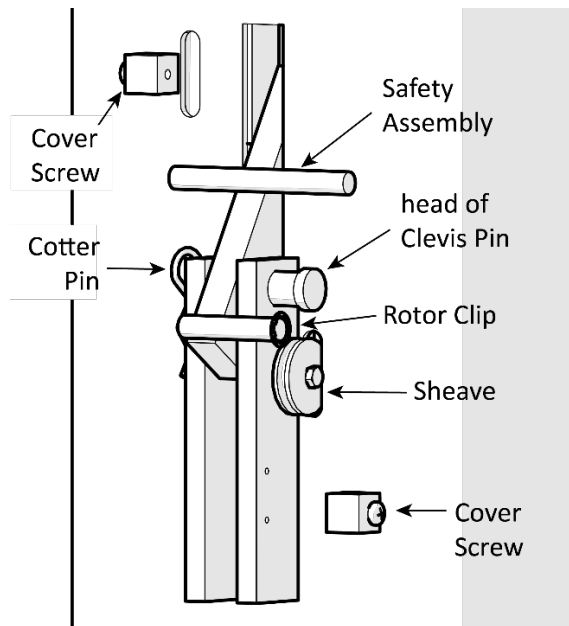

To install the two Safety Assemblies:

1. For the **Powerside Post**, find the Safety Assembly **with** the Safety Lock Release Handle, a Safety Clevis Pin, a Spring, and a Cotter Pin (sometimes called a hairpin).
2. Insert the Safety Clevis Pin, from the right, through the hole in the right welded plate, then through the Safety Assembly, and then through the left welded plate.
3. Put the Spring on the left end of the Safety Clevis Pin, then install the Cotter Pin.

Note: The procedures for the Powerside Post and the Offside Post are quite similar. The difference is that some of the components on the Powerside Safety Assembly are slightly different from the components on the Offside Safety Assembly.

4. For the **Offside Post**, locate the safety assembly **without** the Safety Lock Release Handle, a Safety Clevis Pin and a Cotter Pin.
5. Insert the Safety Clevis Pin, from the right, through the hole in the right welded plate, then through the Safety Assembly, through the left welded plate, and then install the Cotter Pin.

The Safety Cable connects the two Safety Assemblies together.

Note: The Safety Cable should have been installed earlier. The following procedure describes how to hook up the Safety Cable on the Offside Post and on the Powerside Post.

To connect the Safety Cable:

1. On the **Offside Post**, bring the loop end of the Safety Cable down through the inside of the Post.
2. Pull the Safety Cable out to the front of the Offside Post underneath the sheave under the Short Welded Pin; make sure the Safety Cable is sitting correctly in the sheave.
3. Route it over the Short Welded Pin (you will have to remove the Rotor Clip first), put the loop over the right end of the Welded Pin, and then replace the Rotor Clip.

The following graphic show the Safety Cable should look on the Offside Post.

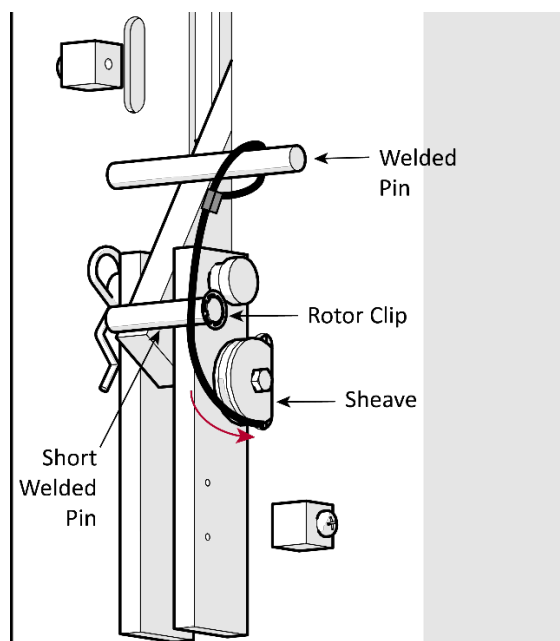

4. On the **Powerside Post**, screw two Nuts onto the threaded end of the Welded Pin with Threads. Make sure that one is on each side of the hole in the Welded Pin with Threads.
5. Bring the straight end of the Safety Cable down through the inside of the Powerside Post.
6. Pull the straight end of the Safety Cable out to the front of the Powerside Post underneath the Safety Sheave; make sure the Safety Cable is seated correctly in the Safety Sheave.
7. Put the straight end of the Safety Cable over the front of the Welded Pin and into the hole in the Welded Pin with Threads, between the two nuts.
8. Pull any slack out of the Safety Cable, then tighten the nuts.

When tightening the nuts, keep tension on the Safety Cable and keep the Safety Cable centered between the two nuts.

The following photo shows how the Safety Cable should look on the **Powerside Post**.

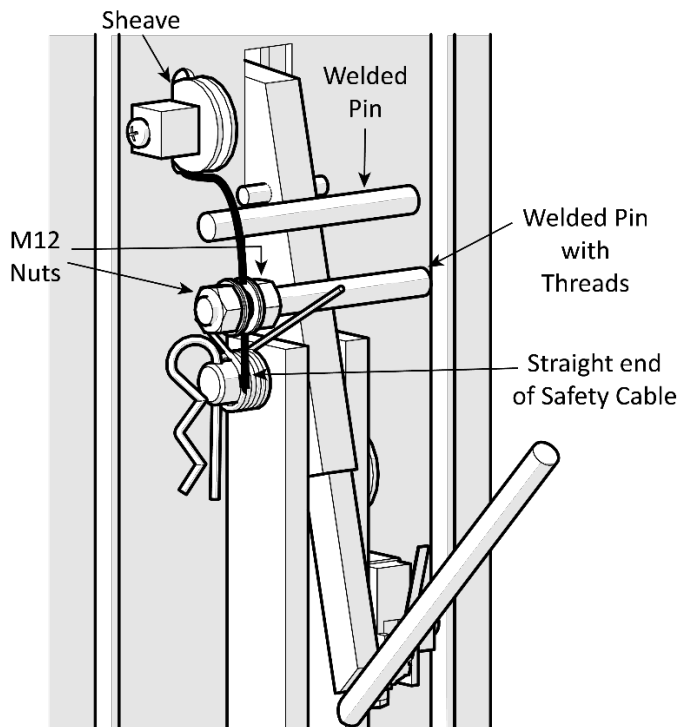

9. Operate the Safety Lock Release Handle, checking for proper operation of both Safety Assemblies.

⚠ DANGER Make sure that both the Powerside and the Offside Safety Assemblies engage properly before using the Lift.

Installing the Trip Stop Tube

The Trip Stop Tube is installed on the underside of the Top Trough.

The Trip-Stop Tube stops upward movement of the Lift; if you are raising a Vehicle and it hits the Trip-Stop Tube, the Lift immediately stops moving up.

To install the Trip Stop Tube:

1. On the **Powerside**, slide the Trip Stop Tube through the welded Post Strap, then fasten the threaded end of the Microswitch Cable through the hole in the tube.

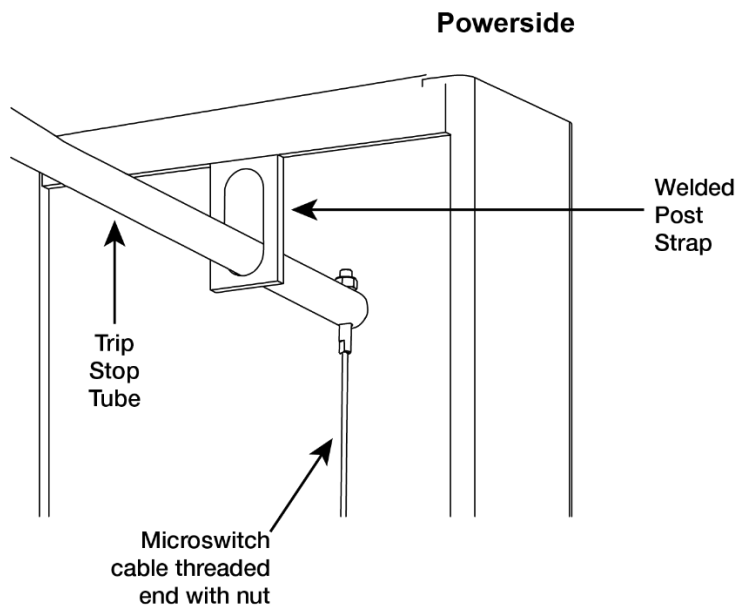

2. Route the loop end of the Microswitch Cable down the inside of the Powerside Post.
3. On the **Offside**, secure the other end of the Trip Stop Tube to the underside of the Top Trough using a 50 mm hex bolt, washer, and nut.

The bolt must be inserted from **inside** the Top Trough.

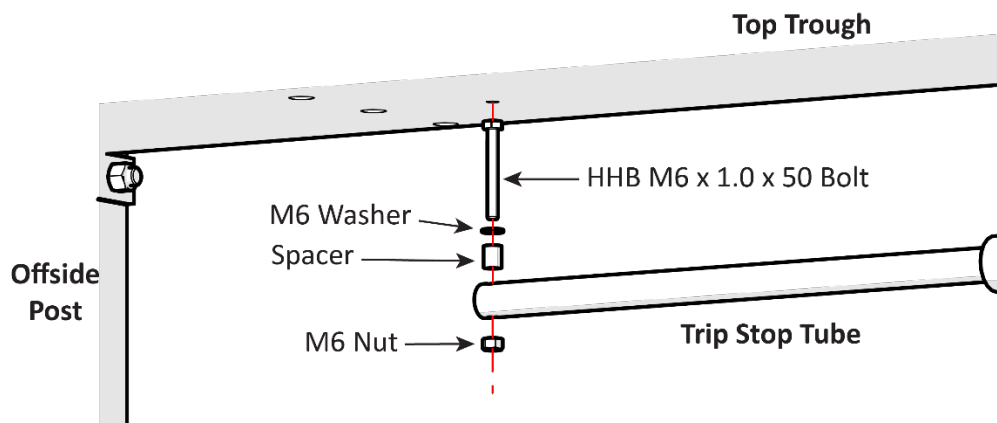

Installing the Microswitch

The Microswitch is the mechanism by which the Trip Stop Tube stops the Lift, if necessary.

To install the Microswitch Cable and the Microswitch:

1. Install the Microswitch Assembly on the right side of the Powerside Safety Assembly using two button head screws.
2. Find the loop end of the Microswitch Cable on the inside of the Powerside Post, then push it through to the outside of the Powerside Post just under the Microswitch Sheave.

Make sure the Microswitch Cable is correctly seated in the Microswitch Sheave.

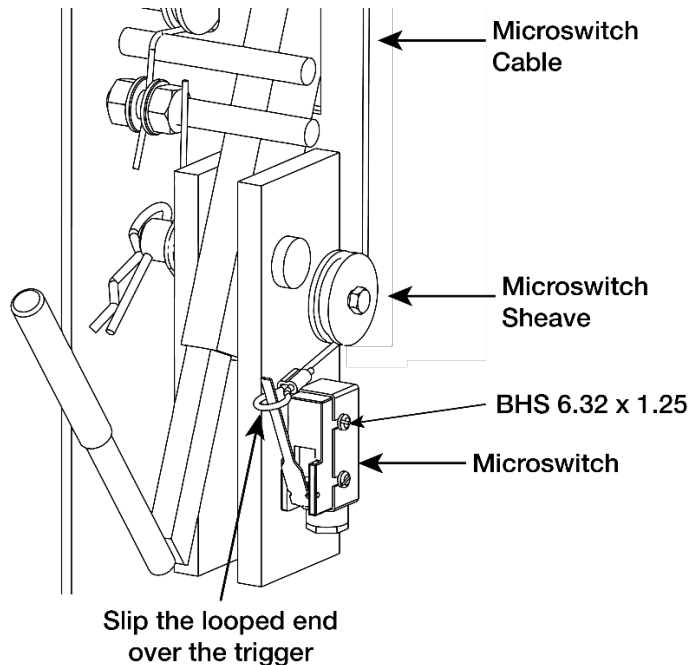

3. Put the loop end of the Microswitch Cable over the trigger on the front of the Microswitch.
4. Have your Electrician wire the cable at the bottom of the Microswitch to your Power Unit.

Make sure the Power Unit is disconnected from the power source. Remove the cover on the Power Unit, then connect the two cables coming from the Microswitch between the switch and the contactor. Reinstall the Power Unit cover.

See [Wiring Diagrams](#) for proper wiring information.

⚠ DANGER All wiring **must** be performed by licensed, certified electricians. Do not perform any maintenance or installation on the Lift without first making sure that main electrical power has been disconnected from the Lift and cannot be re-energized until all procedures are complete.

About Hydraulic Fluid Contamination



IMPORTANT! PLEASE READ NOW



Hydraulic Fluid Contamination poses a serious issue for your Lift; contaminants such as water, dirt, thread seal tape, and other debris can get into the Hydraulic Hoses and Fittings on the Lift, making your new Lift inoperable.

Your Lift is shipped with clean components; however, BendPak strongly recommends that you take secondary precautions and clean all Hydraulic Hoses and Fittings prior to making connections. It is better and less costly to take these extra steps now so that you do not need to take your Lift out of service later to fix issues that could have been prevented.

There are several ways to clean Hydraulic Hoses and Fittings:

- **Compressed Air.** Use an air compressor to blow out contaminants from each Hydraulic Hose and Fitting prior to installation. Clean, dry air is preferred. Wear ANSI-approved eye protection (safety glasses, goggles, or face shield) when using compressed air for cleaning. Never point an air hose nozzle at any part of your body or at a person.
- **Fluid Flushing.** As long as the Hydraulic Fluid is clean and compatible with the system fluid, you can flush Hoses and Fittings to create turbulent flow and remove particulates. Always ensure that the fluid itself is contaminant-free.

Some additional steps that will help keep the Hydraulic Fluid clean:

- **Remove old thread seal tape.** Some ports on the Hydraulic Cylinders are shipped with temporary plugs secured with thread seal tape, so make sure to thoroughly remove any leftover thread seal tape; otherwise, it could get into the Hydraulic System.
- **Use a liquid thread sealant only.** Liquid thread sealant (Loctite™ 5452 or similar) is recommended. **Do not use thread seal tape on any fitting.** Liquid thread sealant is recommended for NPT threads, but *not* necessary for JIC and O-ring (ORB) threads.
- **Always use clean equipment.** If you use a dirty bucket or funnel to transfer Fluid into the Reservoir, the contaminants will get into the Fluid. When using cleaning rags, use a lint-free rag.
- **Proper storage.** Keep the Hydraulic Fluid sealed in its container until ready for use; store the Fluid in a clean, dry, and cool area.
- **Cover the Hoses and Fittings.** Before installation, do not leave the ends of the Fittings exposed; the same applies for the Hydraulic Hoses. Keep the Hydraulic Hoses and Fittings capped and in a clean area until ready for use.
- **Filter the new Hydraulic Fluid.** Just because it is new does not necessarily mean it is *clean*. Use an offline filtration cart or kidney loop system to make sure the Hydraulic Fluid is clean before being transferred into the Hydraulic Fluid Reservoir (even using a heavy duty nylon mesh screen is better than trusting what is left at the bottom of the barrel).
- **Avoid mixing different types of Hydraulic Fluid.** If Hydraulic Fluid needs to be replaced, make sure to flush the Hydraulic System of the old Hydraulic Fluid before you add the replacement Fluid; do not mix the two together.

Hydraulic System Warnings

Before applying power to the Hydraulic System note the following Warnings:

-  **DANGER** Failure to observe these warnings can result in serious personal injury including, in rare cases, death.
-  **DANGER** The Power Unit is a Hydraulic Pump capable of developing pressures in excess of 5,000 psi (345 BAR). A pressure relief valve is used to set the pressure at the desired level. Tampering with, adjusting, modifying, or removing the relief valve is extremely dangerous and is not permitted. Only trained Hydraulics technicians are permitted to adjust the relief valve, using calibrated hydraulic pressure gauges to ensure the proper pressure setting is achieved.
-  **DANGER** Changes to the output pressure may render the power unit incompatible with pressure limitations of other components in the hydraulic circuit. This may cause catastrophic failure of those components, and could result in property damage, serious personal injury or death.
-  **DANGER** The Hydraulic System can contain high pressure which, if suddenly released, can cause serious injury or death.
-  **DANGER** When handling Hydraulic Fluid, always observe the manufacturer's safe handling instructions found in their Material Safety Data Sheet (MSDS).
-  **WARNING** The Hydraulic hoses and connections **must** be inspected before any attempt to raise a Vehicle is made.
-  **WARNING** Verify all Hydraulic Hose connections and fittings, including unused auxiliary port plugs on the Power Unit, the Flow Divider, the Cylinders and anywhere else in the Hydraulic System are tightened.
-  **WARNING** Do **not** attempt to connect or disconnect Hydraulic Hoses while the equipment is loaded or while a Vehicle is on the Lift or the Hydraulic System is under pressure.
-  **WARNING** Keep bare hands away from Hydraulic Fluid; always wear gloves when handling Hydraulic Fluid, Cylinders or Hydraulic Hoses.
-  **WARNING** **Always** promptly clean any Hydraulic Fluid spills. If a leak is the source of the spill, lockout the Lift to prevent use until the Hydraulic System is repaired.

About Thread Sealants

We recommend using a Liquid Thread Sealant (like Loctite™ 5452 or similar PTFE Thread Sealant) to seal the Hydraulic components on your Lift.

Liquid Thread Sealant lubricates and fills the gaps between the Fitting threads and leaves no particles that could contaminate the Hydraulic Fluid. Thread Sealant can be used with most Hydraulic Fittings, although you probably only need it for Hydraulic Fittings with NPT connectors.

To apply Thread Sealant:

1. Make sure the Fittings and connectors you are going to use are clean and dry.

If you are adding Thread Sealant to a Fitting or connector that has already been used with a different Sealant, use a wire brush to thoroughly remove the old Sealant before adding more.

2. Apply a small amount of Thread Sealant to the first four threads of the Fitting.

 **WARNING** Make sure to wear the proper protective equipment when using Thread Sealant.

You only need a small amount because the Sealant will spread to the other threads as the Fitting is tightened into place.

If you put too much, the excess liquid will be pushed out when the Fitting is tightened; use a rag to wipe the excess.

3. Tighten the Fitting into the connector; do **not** over tighten the Fitting.
4. Allow the manufacturer-recommended curing time before pressurizing the system.

Installing the Hydraulic and Return Line

Two Hydraulic Hoses run along the outside of the Powerside Post. They connect to Ports on the Power Unit on one end and to the Valve Block (in the Top Trough) on the other end.

For this procedure, you will need:

- **Two Hydraulic Hoses** (lengths vary depending on model). One Hose functions as the Hydraulic Line, the other Hose is used for the Return Line.
- **Two JIC x NPT Nipple Fittings** (P/N 5550147)
- **One JIC x NPT Elbow Fitting** (P/N 5550106).
- **One JIC x ORB Elbow Fitting** (P/N 5550103).

To install the Hydraulic Hoses:

1. Prepare the Hydraulic components using the information in [Hydraulic Fluid Contamination](#).
2. Remove the Shipping Plugs from the two Hydraulic Ports on the Cylinder Block.

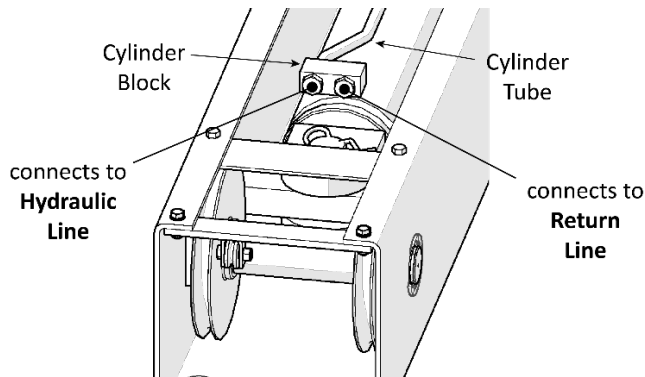

Important:
Depending on your Lift, the Cylinder Tube may be connected to the **Right side** of the Cylinder Block.

The Hydraulic Line **must** be connected to the Port linked to the Cylinder Tube.

3. Attach the NPT end of the Nipple Fitting to each Port on the Cylinder Block; use Liquid Thread Sealant on the NPT threads only.
4. Attach the Hydraulic Hoses to the JIC ends of the Nipple Fittings you just installed.

The following graphic shows the Hydraulic Line and Return Line in place.

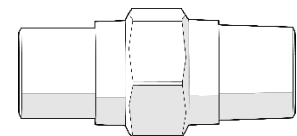
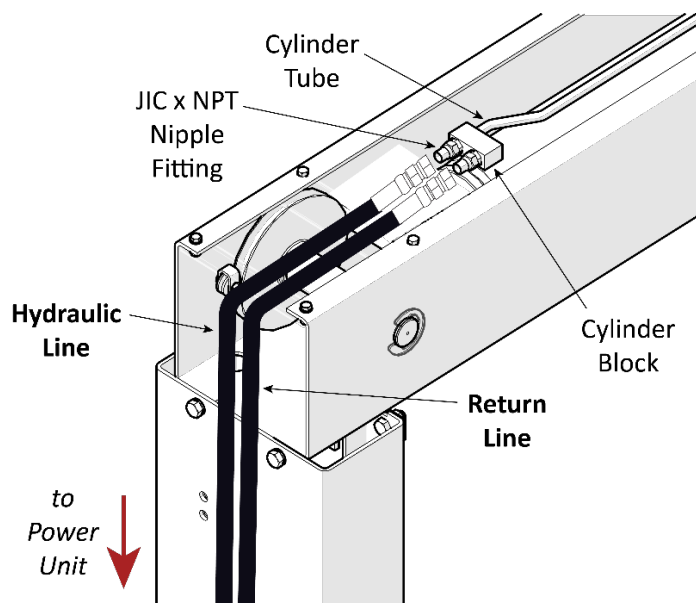

JIC x NPT Nipple Fitting
(P/N 5550147)

- On the Power Unit, remove the plugs from the Hydraulic Pressure Port and Hydraulic Return Port.

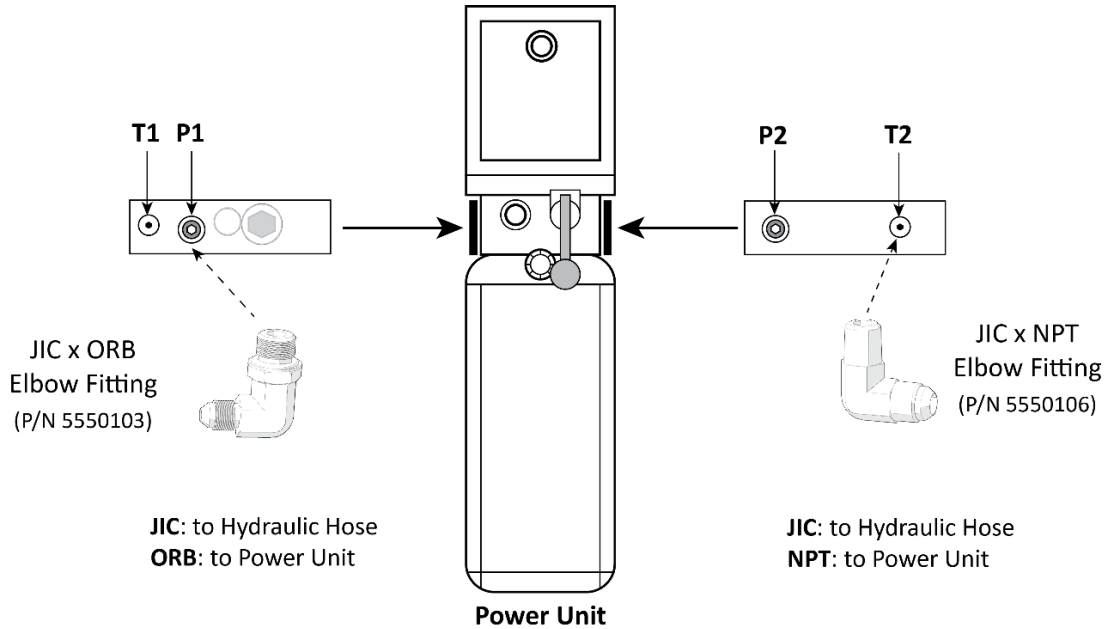

Important Depending on your Power Unit, the Port locations may be slightly different. See [Connect and Prepare the Power Unit](#) for more information.

- Install the two Hydraulic Elbow Fittings to the Power Unit, as shown in the previous drawing. Use liquid thread sealant on the NPT threads. Do **not** use thread seal tape.

WARNING The Hydraulic Line **must** be connected to the port linked to the Cylinder Tube on the Cylinder Block.

- Secure the Hydraulic Line and Return Line to the Powerside Post using the two Pipe Straps.

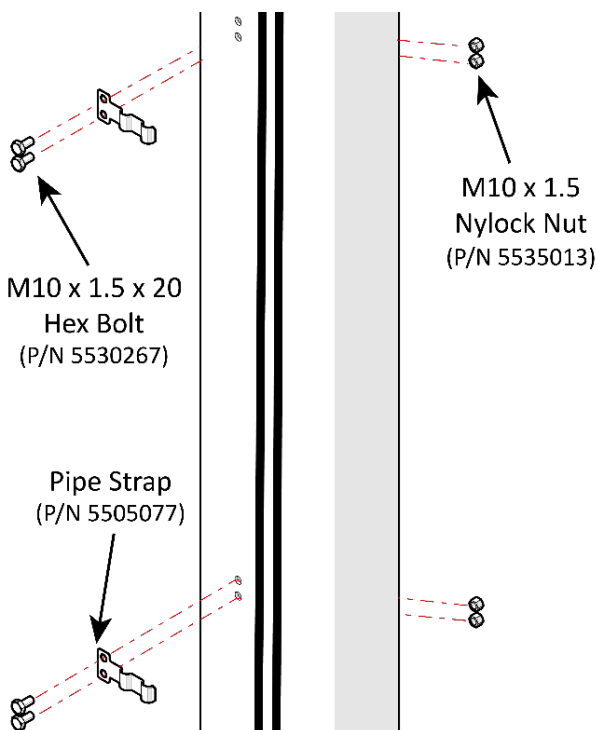

Connecting the Lifting Cables

The threaded ends of the Lifting Cables, which were installed in the Top Trough earlier in the installation, connect to the Lift Heads inside the Offside and Powerside Posts; two Cables per Post.

To connect the Lifting Cables:

1. Inside the Powerside Post, insert the threaded ends of the two Lifting Cables through the holes adjacent to the Retainer on the top of the Lift Heads.

The Retainer holes on the Powerside Post (shown below) are widely spaced, compared to the holes on the Offside Post.

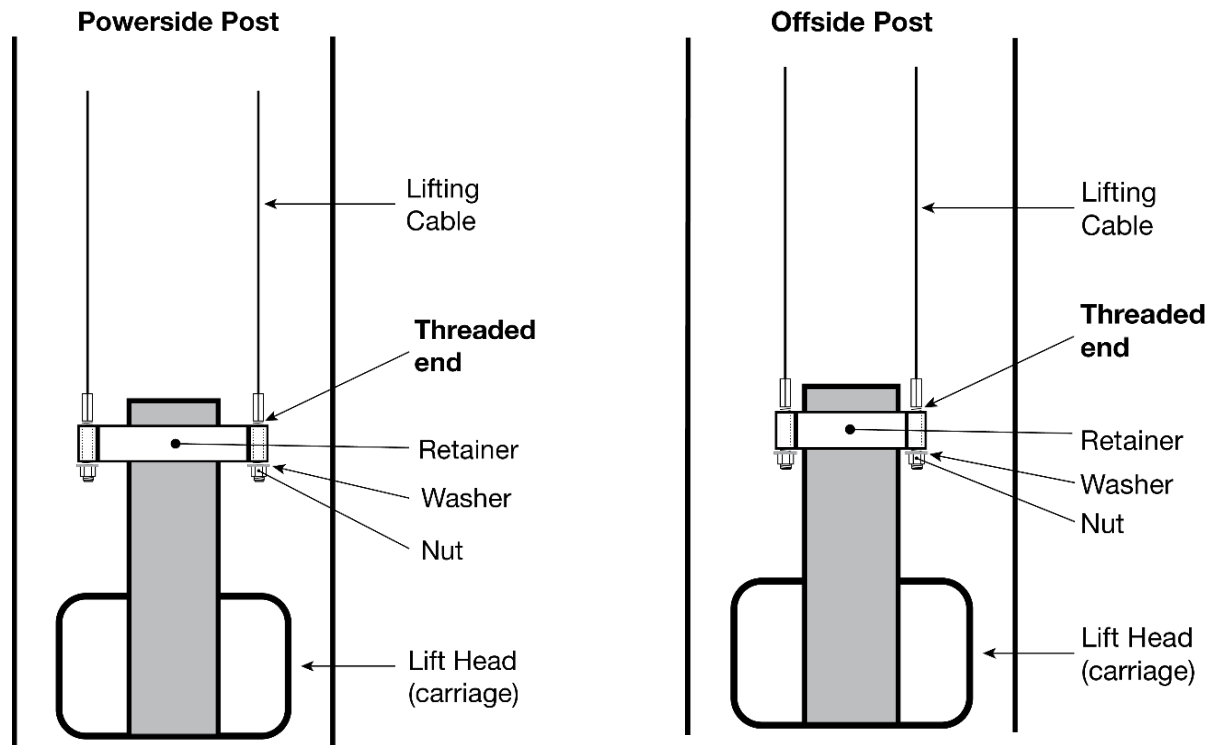

2. Place one M18 washer and M18 Nyloc nut on the threaded end.
Tighten the nuts until taut, making sure both cables have equal tension.
3. For the Offside Post, repeat the same process, except the holes adjacent to the Retainer on the top of the Lift Heads are narrowly spaced, compared to the holes on the Powerside Post.

Installing the Safety Covers

There are two Safety Covers, one for each Safety Assembly. Refer to [Installing the Safety Assemblies and the Safety Cable](#) for more information about Safety Assemblies.

The Safety Covers are **not** interchangeable:

- The Offside Post Safety Cover can be installed in either orientation.
- The Powerside Post Safety Cover can only be installed in one orientation: there is a slot on the front for the Safety Lock Release Handle and a hole in the bottom for the Microswitch Cable.

Both Safety Covers connect to their Posts via holes in the upper left and lower right corners.

To install the Safety Covers:

1. On the Powerside Post, make sure the Cover screws are installed in each block.
There must be enough space between the block and the screw to fit the Safety Cover.

2. Put the Safety Cover into position, then tighten the screws.

The following drawing shows the Powerside Safety Cover.

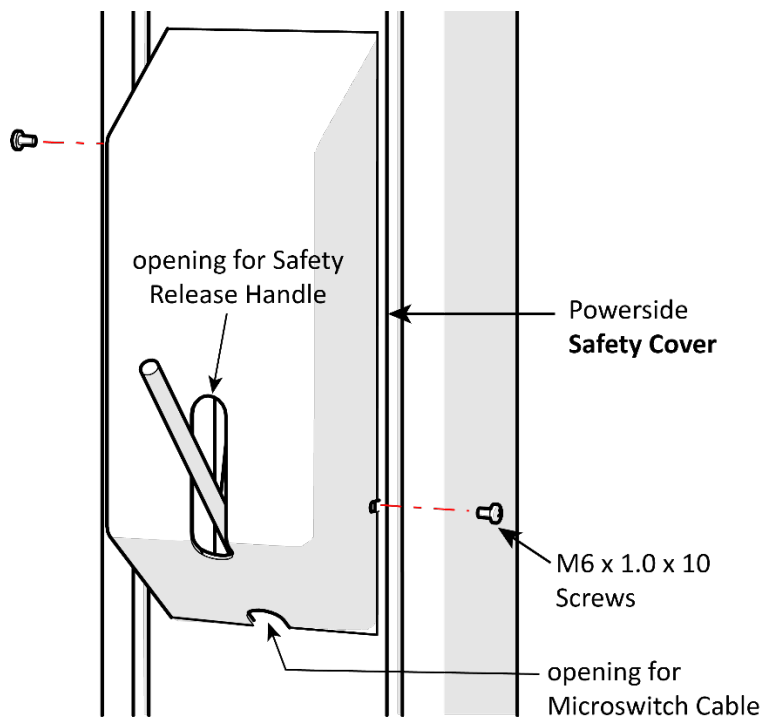

3. Repeat Steps 1 and 2 for the Offside Safety Cover on the Offside Post.

Note: The Offside Safety Cover is similar to the Powerside Cover, but without the opening in the middle.

Installing the Lift Arms

Lift Arms are what actually raise Vehicles off the ground.

Your Lift has four arms:

- **Two Straight Arms:** install them at the rear of the Lift.
- **Two Angled Arms:** install them at the front of the Lift.

To install the Lift arms:

1. Raise a Lift Head two to three inches off the ground.
2. Move a Lift Arm into place in the Lift Head.
3. Install a Lift Head Pin through the Lift Head and the Lift Arm, then push a Snap Ring into its grooves on the bottom of the Lift Head Pin.

Make sure an Angled Arm Spacer is in place on top of each Angled Lift Arm; they are not necessary for Straight Lift Arms.

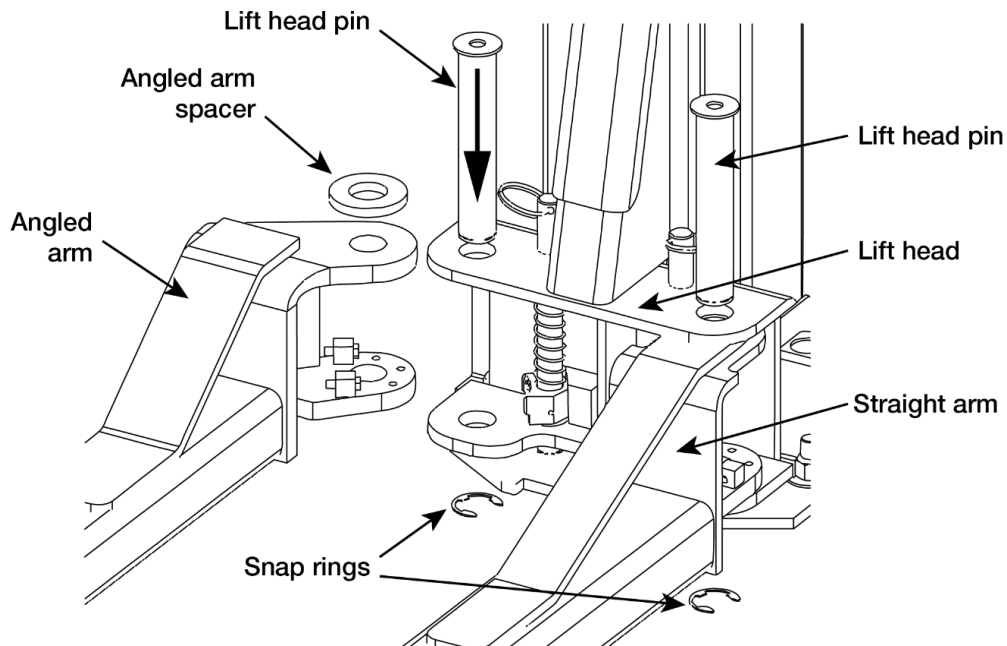

4. Repeat Steps 2 and 3 for each of the other Lift Arms.

⚠ DANGER

The gears must be positioned and adjusted properly. Confirm proper gear engagement prior to operation of the Lift. Periodic inspection and adjustment is also required. Failure to properly inspect and adjust the arm restraint gears on all four arms can result in damage to the Vehicle, injury, or even death.

5. Install the Arm Gear Ring bolts and adjust the Arm Gear Rings so that the teeth on the gear ring mesh fully and smoothly with the teeth on the Arm Restraint Gear.

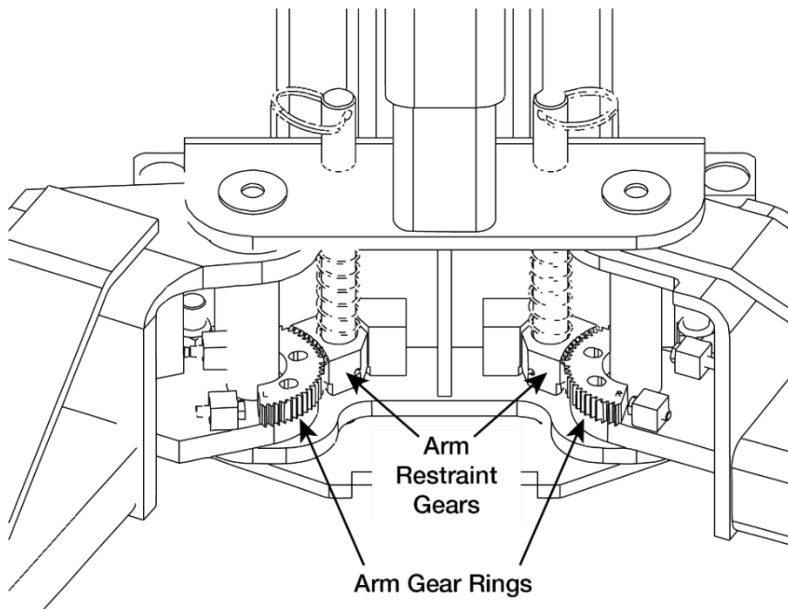

Important: Arm Gear Rings have a Left or Right orientation, based on looking at the Post from the inside of the Lift, as shown above. You must correctly orient the arms.

6. Tighten the Gear Ring bolts.
7. Verify the operation of the Arm restraints by pulling up on the Key Ring of the Arm Restraint Pin. Pivot the arms back and forth and test the operation of the Arm Restraint Pin in various positions.

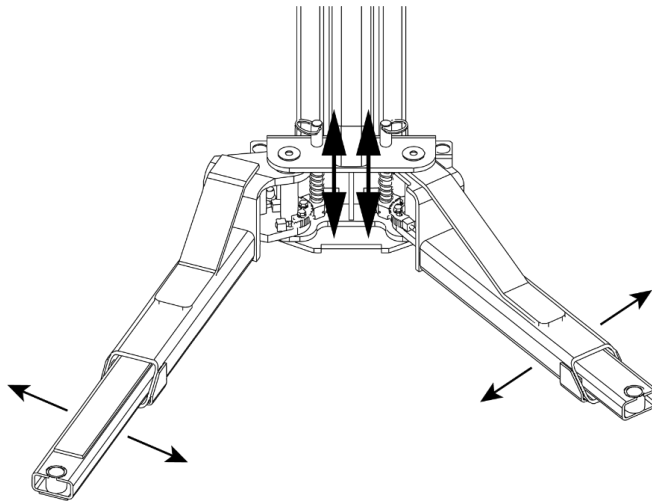

Make sure the Lift Arms do not move when a force of approximately 100 pounds or less is applied laterally to the fully extended arms.

8. Adjust the Gear Ring on each arm as necessary to ensure smooth operation and solid engagement of all four Arm Restraint Pin Assemblies with the Arm Restraint Gear Ring.

⚠ WARNING Each arm restraint assembly must be inspected and adjusted before you use the Lift every time. Do not operate the Lift if any of the four arm restraint systems are not functioning properly. Replace any broken components or components with broken teeth with authorized replacement parts only.

Contact the Electrician

As mentioned previously, there are certain installation tasks that **require** a certified Electrician.

⚠ DANGER All wiring **must** be performed by a licensed, certified Electrician. If someone who is not a certified Electrician attempts these tasks, they could damage the Lift or be electrocuted, resulting in serious injury or even death.

The Electrician needs to:

- **Attach a Power Cable with an appropriate plug.** The Power Unit needs to connect to an appropriate power source; it comes with a pigtail coming out of the Electrical Box, but without a longer power cable or a plug attached. The Electrician needs to remove the pigtail and then connect a power cable with a plug that is appropriate for your location (220 VAC plugs are different in different parts of the world). **This power cable and plug is not provided with the Lift.**
- **Wire the Microswitch.** This is generally done at the same time as the Electrician wires the power source to the Power Unit, as the Microswitch wiring goes between the incoming power source and the Electrical Box on the Power Unit. The Microswitch wiring is provided with the Lift.
- **Install a Power Disconnect Switch.** Ensures you can quickly and completely interrupt electrical power to the Lift in the event of an electrical circuit fault, emergency situation, or when equipment is undergoing service or maintenance. You must put it within sight and easy reach of the Lift operator. Refer to **Install a Power Disconnect Switch** for more information.
- **Install a Thermal Disconnect Switch.** Ensures the equipment shuts down in the event of an overload or an overheated motor. Refer to **Install a Thermal Disconnect Switch** for more information. **The motor on the Power Unit is not thermally protected.**

The Electrician is responsible for providing:

- an appropriate power cable and plug for connecting to the power source
(Wiring to connect the Microswitch is included)
- a UL-listed Power Disconnect Switch
- a Thermal Disconnect Switch

⚠ DANGER Risk of explosion: This equipment has internal arcing or parts that may spark and should not be exposed to flammable vapors. The Power Unit's motor should not be located in a recessed area or below floor level. Never expose the motor to rain or other damp environments; damage to the motor caused by water is not covered by the warranty.

Important electrical information:

- Improper electrical installation can damage the Power Unit motor and **is not covered by warranty.**
- Use a separate circuit breaker for each Power Unit.
- Protect each circuit with a time delay fuse or circuit breaker:
For a 208 to 230 VAC, **single phase** circuit, use a 25 amp fuse.

Connect and Prepare the Power Unit

There are several things you need to do to get your Power Unit ready for normal operation:

- Attach the Power Unit to the Powerside Post. Should already be done, described in [Installing the Power Unit](#).
- Attach the Hydraulic Hose and the Return Line to the correct locations on the Power Unit. Should already be done, described in [Installing the Hydraulic and Return Line](#).
- Wire the Power Unit and Microswitch to a power source. Covered in this section.
- Fill the Hydraulic Fluid reservoir. Covered in [Add Hydraulic Fluid](#).

Note: The following procedure assumes the Power Unit is attached to the Powerside Post and that the Hydraulic and Return Lines are connected to the Power Unit. If these things are **not** done yet, do them **before** you perform the following procedure.

To connect and prepare the Power Unit:

1. Have the Electrician locate the Pigtail coming out of the Electrical Box on the Power Unit.

⚠ DANGER All wiring **must** be performed by a licensed, certified Electrician. If someone who is not a certified Electrician attempts these tasks, they could damage the Lift or be electrocuted, resulting in serious injury or even death.

2. Open the Electrical Box, remove the Pigtail, and then wire the power cord (with appropriate plug) *inside the Electrical Box* to the wires that were connected to the Pigtail.

Refer to [Wiring Diagrams](#) for proper wiring information.

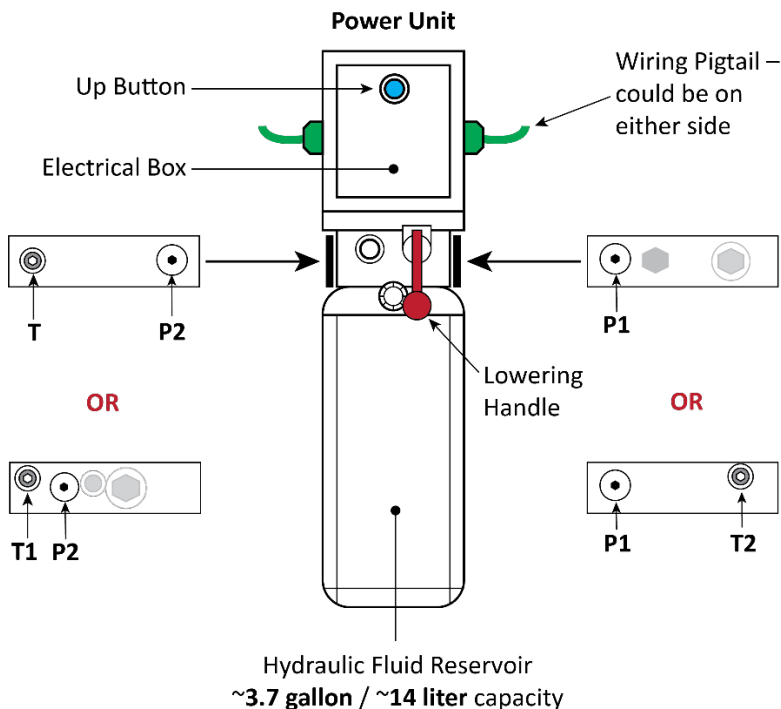

Important Notes:

Hydraulic Pressure Ports are almost always labeled **P1/P2** on the Power Unit.

Hydraulic Return Ports are commonly labeled as **T1/T2** or **CV1/CV2** on the Power Unit.

3. Wire the Microswitch to the incoming power source.

Refer to [Wiring Diagrams](#) for proper wiring information.

Add Hydraulic Fluid

The Hydraulic Fluid Reservoir on the Power Unit must be filled with Hydraulic Fluid or automatic transmission fluid **before** you begin normal operation of the Lift. **When you receive the Lift, the fluid reservoir is empty.**

The Hydraulic Fluid Reservoir holds approximately **3.7 gallons / ~14 liters**.

The Power Unit will **not** work correctly until the reservoir is filled with approved Hydraulic Fluid.

Approved fluids are any general purpose ISO-32, ISO-46, or ISO-68 Hydraulic Fluid, approved automatic transmission fluids such as Dexron III, Dexron VI, Mercon V, Mercon LV, or any synthetic multi-Vehicle automatic transmission fluid.

⚠ WARNING Do not run your Power Unit without Hydraulic Fluid; you will damage it.

To fill the Hydraulic Fluid Reservoir:

1. Remove the Reservoir Cap from the top of the Hydraulic Fluid Reservoir.

Take care to **keep contaminants out** of the Hydraulic Fluid Reservoir when filling it.

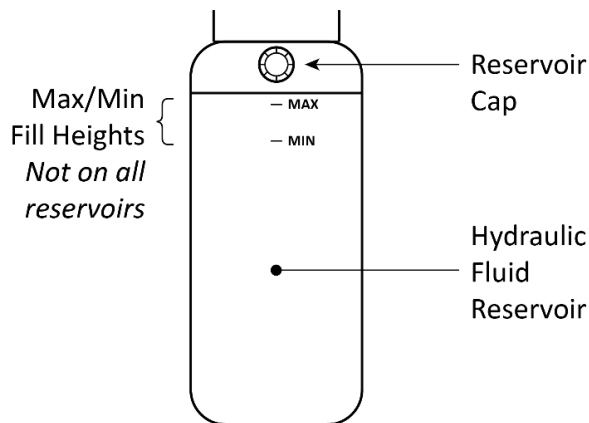

Some reservoirs look slightly different. Not necessarily to scale. Not all components shown.

2. Fill it with approved fluid; approximately **3.7 gallons / 14 liters**

Use care to keep the fluid clean when filling the Reservoir.

Important: If 3.7 gallons / 14 liters does not seem like an appropriate amount for the Reservoir on your Power Unit, fill the Reservoir up to the MAX line on the Reservoir or to .5 in / 12.5 mm under the Reservoir Cap if no MAX line is present.

3. If the Reservoir is low, add approved fluid until the fluid level is at least at the minimum level; maximum level is best.

If your Reservoir does not have MAX/MIN markings, full is approximately .5 in / 12.5 mm under the Reservoir Cap.

4. When the Reservoir is filled, put the Reservoir Cap back on.

Installing a Power Disconnect Switch

WARNING

A Power Disconnect Switch is **not** provided with this equipment.

A Power Disconnect Switch is a National Electrical Code (NEC) requirement. They are designed to interrupt main electrical power in the event of an electrical circuit fault, emergency situation, or when equipment is undergoing service or maintenance.

Make sure to install a Power Disconnect Switch that is properly rated for the incoming power source.

Your Power Disconnect Switch must be readily accessible and installed so that it is in easy reach of the operator or in their line of sight. The Power Disconnect Switch must be clearly marked to indicate its purpose.

The figure to the right shows a toggle-style Power Disconnect Switch located between the Lift's power source and its Power Unit. A quick flip of the switch immediately cuts power to the Lift.

In the case of the GP-7, the location directly above the Power Unit is being used by the Lowering Handle, so your Electrician may want to move the Power Disconnect Switch location up a little.

 **DANGER** Installing a Thermal Disconnect Switch **must** be performed by a licensed, certified Electrician.

Have the Electrician select a **UL-listed** Power Disconnect Switch.

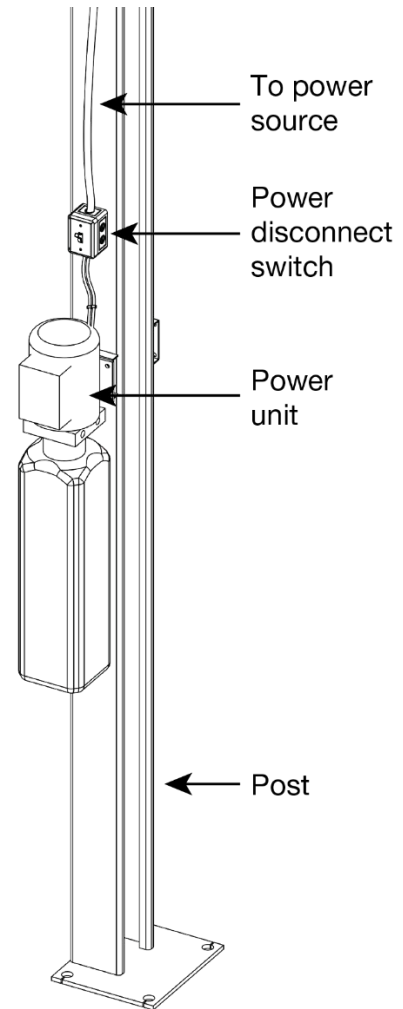

Installing a Thermal Disconnect Switch

The Power Unit supplied with this Lift **does not** include thermal overload protection. Under NEC 430, UL 201, and CSA C22.2 No. 68 intermittent duty motors are not required to include thermal protection. Local electrical codes may vary, and other requirements may exist that the installing electrician will address, if required.

 **DANGER** If local Electrical codes require the installation of a Thermal Disconnect, the disconnecting device and the installation **must** be provided by a licensed Electrician in accordance with local electrical codes. Do not perform **any** maintenance or installation on the Lift without first verifying that main electrical power has been disconnected from the Lift and **cannot** be re-energized until all procedures are complete.

High running amps that exceed the motor's full load amps (FLA) rating may result in permanent damage to the motor.

BendPak strongly recommends you **not** exceed the rated duty cycle of the GP-7 Series Lift motor.

Final Leveling

Before operating your Lift, you need to make sure that both the Lift posts and the Lift arms are level:

- **Lift Posts:** The Posts **must** be the same distance apart at the top and at the bottom.

To make sure the Posts are level, measure the distance between the two Posts six inches below the Top Trough and one foot off the ground (you will need to move the Lift Arms out of the way). The two measurements (**A** and **B** in the drawing below) must be the same.

If the Posts are not level, shim them as required.

- **Lift Arms:** When the Lift Posts are level, make sure the Lift Arms are level as well. To make sure they are level, raise them to the first locking position and put a level on the pads.

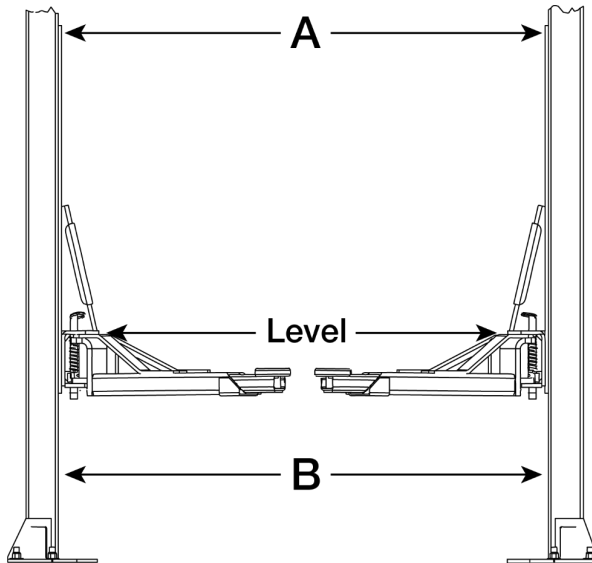

Torque the Anchor Bolts

Make sure all Anchor Bolts are correctly torqued.

Torque the Nut of each Anchor Bolt **clockwise** to the recommended installation torque, 85 – 95 pound feet, using a Torque Wrench.

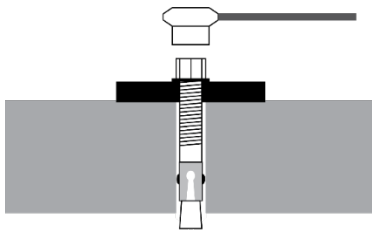

Important: Do **not** use an impact wrench to torque the Anchor Bolts.

Torquing the Nut forces the Wedge up, pushing out the Expansion Sleeve and pressing it tightly against the Concrete.

Lubricate the Lift

BendPak recommends lubricating the following locations on the Lift before starting normal operation and on a monthly basis afterwards, to keep your Lift working better and longer:

- The four inside corners of both Posts (which is where the Slide Blocks slide)
- The pins of the Microswitch Sheave and the Safety Sheaves

We recommend using white lithium grease or light axle grease as the lubricant.

Bleeding the Hydraulic Cylinder

Bleeding the Hydraulic Cylinder removes excess air from the cylinder. Air in the Hydraulic Cylinder can cause the Lift to move erratically or make odd noises.

The Hydraulic Cylinder is self-bleeding, which means you just have to use the Lift a few times and excess air will get worked out of the Hydraulic System.

To bleed the Hydraulic Cylinder:

1. Raise and lower the Lift four or five times; **you must wait 30 seconds between each cycle.**
Refer to **Operation** for raising and lowering instructions.
2. Check the Hydraulic Fluid level; it may be down as a result of using the Hydraulic System.
Add more Hydraulic Fluid if necessary. Lift must be fully lowered to change the Hydraulic Fluid.
3. Raise the Lift to full rise and run the motor for approximately three seconds after the Lift stops.
This places pressure on the Hydraulic System.
4. Stop and check all fittings and hose connections; tighten or reseal if required.
5. Lower the Lift back to the ground.

Perform an Operational Test

Before putting your Lift into normal operation, we recommend raising and lowering it several times with a typical Vehicle on the Lift. This will help you get a feel for how to operate the controls and help get any residual air out of the Hydraulic System (sometimes called “bleeding” the system).

⚠ DANGER Automotive Lifts are dangerous tools when used by inexperienced, impaired, or distracted technicians. When you even hear the words “automotive lift,” your brain should automatically register the fact that lifting a vehicle is a serious endeavor with life-threatening risks if mandatory lifting precautions are ignored.

During the Operational Test, check for proper installation and operation. Do not raise any additional Vehicles until a thorough Operational Test has been done with a typical Vehicle.

⚠ WARNING Never raise a Vehicle whose weight exceeds the rated capacity of the Lift. Do not leave the controls until the Lift is engaged on its Safety Locks. Only trained personnel should raise or lower the Lift.

To perform an Operational Test:

1. Follow the instructions in **Raising the Lift** and **Lowering the Lift** to safely raise and lower a Vehicle on the Lift.

⚠ WARNING Be sure to follow the instructions carefully when it comes to contacting the manufacturer’s recommended Lifting Points on the underside of the Vehicle. If you do not, the Vehicle could become unstable and fall, which could damage the Vehicle, damage the Lift, and injure or even kill anyone under the Vehicle.

2. Adjust the Lift Arms under the Vehicle so the Adapters are **directly under** the Lifting Points for the Vehicle you are raising.

If necessary, use the included Lift Pad extensions for extra height.

3. Raise the Lift until **just before** the Lift Pads make contact with the Lifting Points.

If this is the very first use of the Lift, it will take a few seconds to start rising. The Hydraulic Fluid has to fill the Hydraulic Lines before the Lift starts to rise.

4. Check the Arm Restraint Gears on all four Lift Arms to make sure they are engaged.

If they are not engaged, move the Lift Arms back and forth until they engage.

5. Raise the Lift until the tires of the Vehicle are a few inches off the ground.

6. Check to make sure all four Lift Pads are making solid contact with the Lifting Points.

If any of the Lift Pads are **not** making solid contact with the Lifting Points, carefully lower the Lift and start over again; the Lift Pads **must** make solid contact with the Lifting Points.

7. Raise the Vehicle approximately three feet (one meter) off the ground, then lower it back down.

The Lift may move erratically or make some odd noises the first few times you use it; this is normal.



Tip

Residual air in the Hydraulic System can cause the Lift to shake, move erratically, or squeak; this is normal when you first start using the Lift. It will soon stop doing this, as the Hydraulic System is self-bleeding.

8. Wait for one minute.

NOTICE The Power Unit is not a constant duty motor; **it cannot be run continuously.**

9. Repeat the process, this time raising the Lift, engaging it on a Safety Lock position, taking it off the Safety Lock position, and then lowering it back down to the ground.

Again, follow the instructions in **Raising the Lift** and **Lowering the Lift** to safely raise and lower a Vehicle on the Lift, including engaging it on its Safety Locks.

10. If the Lift is working without shaking, moving erratically, or squeaking, there is no need to repeat the procedure.

If the Lift is shaking, moving erratically, or squeaking, repeat the procedure one more time.

If you continue to have issues, refer to **Troubleshooting** for assistance.

11. When the Lift is on the ground and the Vehicle is on all four tires, move the four Lift Arms to their full drive-through positions.

12. Drive the Vehicle out.

13. With no Vehicle on the Lift Arms, press and hold the Up button on the Power Unit.

The Lift Arms start rising.

14. Have another person push up the Safety Shutoff Bar until it triggers the Microswitch.

The Lift Arms should stop rising.

If the Lift Arms do not stop rising when the Microswitch is triggered, this means the Microswitch is either not installed correctly or not wired correctly. Return to the sections of this manual where installation and wiring of the Microswitch is described to find and fix the problem.

CAUTION Do not put the Lift into normal operation until you have confirmed that triggering the Microswitch stops the Lift Arms from rising.

Final Checklist Before Operation

Make sure these things have been done **before** using your Lift:

- Review the **Installation Checklist** to make sure all steps have been performed.
- Verify the Power Unit is supplied power from the power source.
- Check the Hydraulic Fluid reservoir on the Power Unit; it must be full of approved fluid. **You will harm the motor by running it without enough fluid.**
- Check the Hydraulic System for leaks.
- Verify both Posts are properly shimmed, stable, and level.
- Verify all Anchor Bolts are correctly torqued.
- Verify sure the inside of the Posts have been lubricated.
- Verify all Cables are properly positioned in their Sheaves.
- Verify all Cable Sheave retaining pins and/or clips are secure.
- Verify all Safety Locks are cleared and free.
- Verify Operational Test was successfully performed.
- Verify *Installation and Operation Manual* is available for all operators.

Operation

This section describes how to operate your GP-7 Lift.

Important! - A complete pre-operation inspection is required before using this equipment.

⚠ DANGER Automotive Lifts are dangerous when used by inexperienced, impaired, or distracted operators. When you even hear the words “automotive lift,” your brain should automatically register the fact that lifting a Vehicle is a serious endeavor with life-threatening risks, especially if mandatory lifting precautions are ignored.

Lift Operation Safety Rules

⚠ DANGER Your safety depends on reading, understanding, and implementing these Safety Rules. Do not skip over them; read them carefully and follow them!

Do the following before you raise or lower a Vehicle using your Lift:

- **Check the Lift.** Check the Lift for any missing, heavily worn, or damaged parts. Do not operate the Lift if you find any issues; instead, take it out of service, contact your dealer, email support@bendpak.com or call **(800) 253-2363**.
- **Check the area.** Keep the area around the Lift clean and free of obstructions; anything that could cause a problem for the Lift. Do not forget to check **above** the Lift. If you find an obstruction, move it out of the way. **Do not allow any people or animals within 30 feet of the Lift while it is being used.**
- **Check the operators.** Make sure everyone who is going to operate the Lift has been trained in its use, has read the labels on the unit, and has read the manual. Only the operator at the controls should be within 30 feet of the Lift when it is being used. Do not allow children to operate the Lift. Do not allow anyone under the influence of drugs, alcohol, or medication to operate the Lift.
- **Check for safety.** Make sure everyone who is going to be walking near the Lift is aware of its presence and takes appropriate safety measures. Only put Vehicles on the Lift Arms. **When raising a Vehicle on the Lift, do not leave it until it is engaged on its Safety Locks.** When lowering the Lift, do not leave it until it is on the ground.
- **Check the Vehicle.** Never exceed the Lift’s weight rating. Do not allow people inside a Vehicle you are going to raise. Make sure the Vehicle is not overbalanced on either end. Make sure you know the manufacturer’s recommended Lifting Points for the Vehicle. Never raise just one side, one corner, or one end of a Vehicle.

⚠ WARNING Always use care when you are around your Lift. When it is in a lowered position, be careful not to trip over it. When it is raised, be careful not to hit your head on the Lift Arms or the Vehicle. **When you are raising or lowering a Vehicle, keep all people, animals, and objects at least 30 feet away from the Lift.**

About Lifting Points, Adapters, and Auxiliary Adapters

An important note to keep in mind when using a frame-engaging Lift is that the raised Vehicle must be balanced on the four Lift Arms. If the Vehicle is not balanced, it is more likely to become unstable and slide off the Lift, possibly damaging the Lift, the Vehicle, and anything under the Lift, including injuring people.

 **WARNING** You **must** use all four Lift Arms when raising a Vehicle. Never use just one, two, or three Lift Arms to raise a Vehicle. The Vehicle will be unstable and could slip off the Lift, possibly damaging the Lift, damaging the Vehicle, and injuring anyone under it.

To balance a Vehicle on a frame-engaging Lift, you need to have the Adapters (also called Pads) contact the Vehicle on the manufacturer's recommended Lifting Points. By definition, when you raise a Vehicle by its Lifting Points, the Vehicle is balanced.

NOTICE The manufacturer's recommended Lifting Points do not take into consideration any major changes that might have been made to the Vehicle. If the motor is removed, for instance, or there is a 5,000 pound / 2,268 kg weight in the trunk, the Vehicle's Lifting Points will not be the best balancing points.

So how do you find the manufacturer's recommended Lifting Points? Some Vehicles have indicators on the underside that identify the Lifting Points; many do not.

Your best approach is to find the Vehicle in the book *Vehicle Lifting Points for Frame Engaging Lifts*, which was provided with your Lift, refer to the respective vehicle's service repair manual (not owner's manual) or contact the dealer or manufacturer of the Vehicle. The book also includes a page of safe lifting suggestions, which everyone who uses the Lift should read.

The guide *Lifting it Right: A Safety Manual from the Automotive Lift Institute*, also provided with your Lift, includes a wide variety of information about Lifts and how to use them safely.

Raising the Lift

This section describes how to raise a Vehicle on the Lift.

 **WARNING** Never raise a Vehicle whose weight exceeds the rated capacity of the Lift. Do not leave the controls until the Lift is engaged on its Safety Locks.

To raise a Vehicle:

1. Make sure the Lift Arms are on the ground in their full drive-thru position.
2. Drive the Vehicle in. When you are satisfied with the location of the Vehicle, put it in park, put on the parking brake, and turn off the motor.

If the Vehicle is a manual transmission, put it into first gear before turning off the motor.

 **CAUTION** When driving a Vehicle in, keep to the middle of the area between the Posts. If you hit any portion of the Lift, you could damage the Vehicle and/or the Lift.

3. Get out of the Vehicle; open the doors carefully to avoid banging them on the Lift.
4. Adjust the Lift Arms under the Vehicle so that the Lift Pads are directly under the manufacturer recommended Lifting Points for that specific Vehicle.

If necessary, use the included extensions to get the Lift Pads close under the Lifting Points.

5. Press and hold the **Up** Pushbutton. Release **Up** when the Lift Pads are **just under** the Lifting Points.

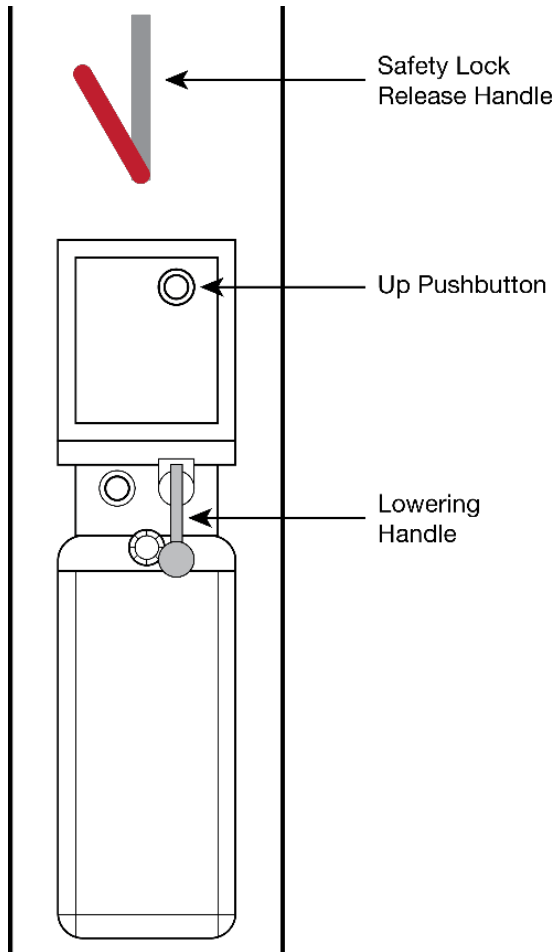

6. Check all four Lift Arms again to make sure the Lift Pads are directly under the Lifting Points.
If they are not, adjust them so that they are. If necessary, move the Lift all the way back down to the ground and start over.
7. Push the **Up** Pushbutton to raise the Vehicle until it is a few inches off the ground.
8. Release the **Up** Pushbutton, then check to make sure the Lift Pads have solid contact with the Vehicle's Lifting Points and that the Vehicle is balanced on all four of the Lift Arms.
You can give the Vehicle a slight push to make sure it is solid and balanced.
If the Vehicle is **not** solid or **not** well balanced, lower it back to the ground (see **Lowering the Lift** for the lowering procedure) and make the necessary adjustments.
9. Push in and hold the **Up** Pushbutton.
10. When the Vehicle reaches the desired height, go up a bit further, then release the **Up** Pushbutton.
11. **Press and hold** the Lowering Handle to lower the Lift down and engage it on the nearest Safety Lock.
12. Verify that both Lift Heads are on a Safety Lock and that the Safety Locks they are on are at the same height.

⚠ WARNING If the Lift Heads are engaged on Safety Locks at different heights, this is dangerous. Carefully lower the Lift back down to the ground and start over. Do **not** leave the Lift control until the Lift is engaged on its Safety Locks or on the ground.

If the Lift continues to engage on Safety Locks at different heights, refer to [Troubleshooting](#).

13. Begin work on the Vehicle.

Lowering the Lift

To lower the Lift, you first raise it a small amount to get it off the Safety Lock, then bring it down.

To lower the Lift:

1. Check under and around the Vehicle to make sure the area is clear of all obstructions. If you find any, move them out of the way.
2. **Press and hold** the **Up** Pushbutton for a few seconds to move the Lift off its Safety Locks.
Raise the Lift at least two inches to get clear of the Safety Locks.
3. Push in and hold the Safety Lock Release Handle and Lowering Handle (on the Power Unit) at the same time in order to lower the Lift.

 **WARNING:** Do not override the Lift controls; they are designed specifically to return to off when released. If the Lift controls are overridden, the Vehicle could fall off the Lift, possibly causing damage to the Vehicle, damage to the Lift, or injuries to the Lift operator or anyone else in the immediate vicinity.

Remain clear of the Lift as it comes down; obey the pinch point warning decals.

4. When the Lift is fully lowered, release both handles, move the Lift Arms to their full drive-thru positions, and then drive the Vehicle out.

About Safety Locks

Your Lift has 11 Safety Lock positions, spaced every four inches; having multiple Safety Lock positions lets you lock the Lift at the best height for what you want to do.

A Safety Lock **position** is when the Lift is engaged on both of the Lift's Safety Locks at the **same height on both Posts**.

Important: Always make sure both Safety Locks are engaged at the same height on both Posts. You do not want the Lift engaged on Safety Locks of two different heights or the Safety Lock on one Post engaged but the Safety Lock on the other Post not engaged.

Safety Lock positions are created by the Safety Lock Weldments, which are on the back of the Lift Heads. Safety Lock Weldments hit the Safety Locks and then move past them as the Lift Heads rise.

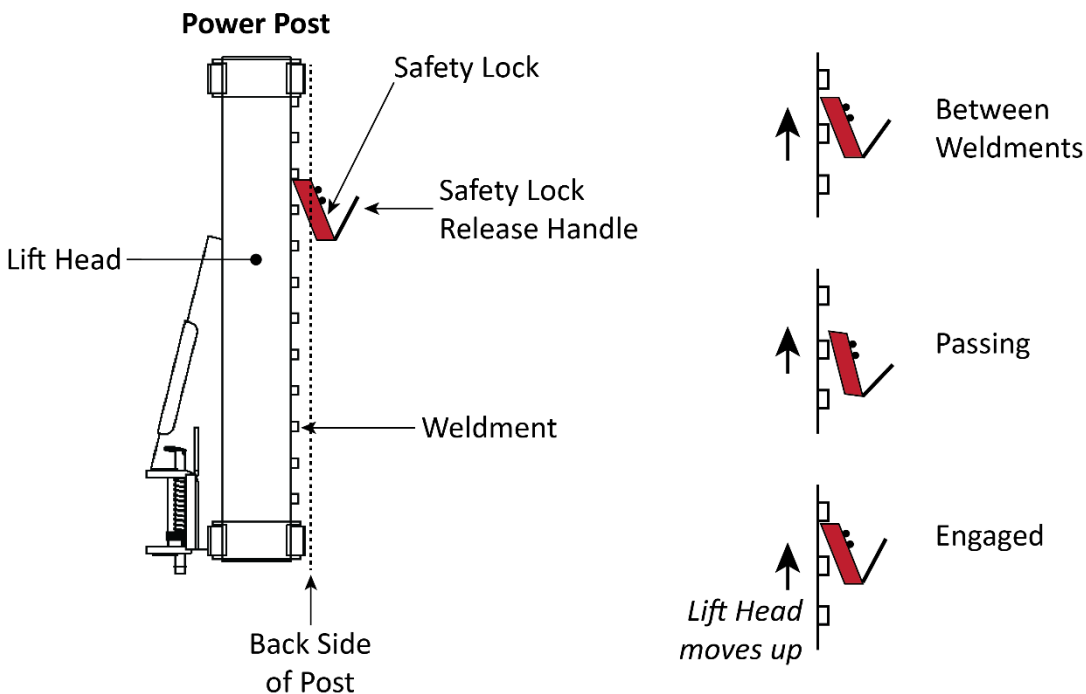

Drawing not necessarily to scale. Not all components shown. Posts not shown for clarity. Offside Safety Lock not shown.

As they move past the Safety Locks, the Weldments push the Safety Lock and the Safety Lock Release Handle down (Handle on Powerside Post only). When the Weldment is completely past the Safety Locks, the Safety Locks clank back into position between Weldments. This happens each time Safety Locks are passed, so you will generally be hearing multiple clanks as the Lift rises and lowers.

To engage the Lift on a Safety Lock position, wait until the Vehicle reaches the desired height for the work you are going to do, then listen for the clank as the Weldments pass the next Safety Lock position. When you hear the clank, release the Up Button and then hold down the Lowering Handle (on the front of the Power Unit) for a second or two to back the Weldments down onto the just-passed Safety Locks; **do not** hold down the Safety Lock Release Handle.

⚠ WARNING Only leave the Lift either fully lowered or engaged on Safety Locks. **If you leave the Lift raised but not engaged on Safety Locks, the Vehicle is not secure.** It could fall, possibly damaging the Vehicle, the Lift, and injuring or even killing anyone nearby.

Maintenance

⚠ DANGER Before performing any maintenance, make sure the Lift is completely disconnected from power and **cannot** be re-energized until all maintenance is complete. If the power is re-energized during maintenance, you or someone else could be electrocuted. BendPak strongly recommends using your Power Disconnect Switch during maintenance. If your organization has Lockout/Tag Out policies, be sure to implement them to ensure no-one can start the Lift while maintenance is in process.

Read your manual and understand how this equipment works before using, maintaining or repairing. Routine maintenance and adjustments are the responsibility of the owner/user and are not covered under warranty.

Routine maintenance and adjustments should be carried out on a regular basis. *Unless stated otherwise, all maintenance may be performed by the owner/employer and does not require trained lift service personnel.* Replace worn, damaged or broken parts with original BendPak or BendPak approved parts or with parts.

To maintain your Lift:

- **Daily:** Keep the GP-7 Lift clean. Wipe up any spills, clean any dirt.
- **Daily:** Make a visual inspection of all moving parts and check for damage or excessive wear. Replace any damaged or worn parts before using the Lift.

⚠ DANGER Do not use the Lift if the cables are damaged or badly worn. If a Vehicle is raised when you notice the damage or extreme wear, very carefully lower the Vehicle to the ground. When the Lift is on the ground, remove it from service, disconnect it from power, and make arrangements to have it fixed.

- **Daily:** Make sure Safety Locks are in good operating condition. Do not use your Lift if the Safety Locks are damaged or excessively worn.
- **Weekly:** Check the controls to make sure they are functioning normally.
- **Weekly:** Check all labels on the Lift. Replace them if they are illegible or missing.
- **Monthly:** Lubricate the Posts and the Sheave Pins. We recommend using white lithium grease.
- **Monthly:** Check the Hydraulic Fluid levels in the reservoir on the Power Unit. Refill if low. Only measure fluid levels when the Lift is fully lowered.
- **Monthly:** Check cable connections, bolts, and pins for proper mounting and torque.
- **Monthly:** Check arm adjusting locks for proper operation.
- **Monthly:** Make sure all pivot arm pins are properly secure.
- **Every two months:** Check all Anchor Bolts to make sure they are correctly torqued. If they are not, torque them.
- **Every three months:** Check the lubrication of the Wire Rope.
- **Every three to five years or as needed.** Carefully check the Lifting Cables if there are signs of damage or excessive wear. See **Wire Rope Inspection and Maintenance** for additional information.
- If the Lift becomes inoperative in a raised position, see the **Troubleshooting** section.
- The GP-7 maximum operating hydraulic pressure developed upon lifting its maximum capacity of 7,000 lbs./ 3,175 kg. is 2,300 psi.

⚠ WARNING: Do not operate your Lift if you find maintenance issues; instead, remove it from service, then contact your dealer, visit [bendpak.com/support](https://www.bendpak.com/support), email support@bendpak.com, or call **(800) 253-2363**.

GP-7 Wire Rope Inspection and Maintenance

The GP-7 wire ropes, should be inspected regularly:

- Wire rope should be replaced when there are visible signs of damage or extreme wear. *Do not use the Lift if it has damaged or worn Cables; **take it out of service!***

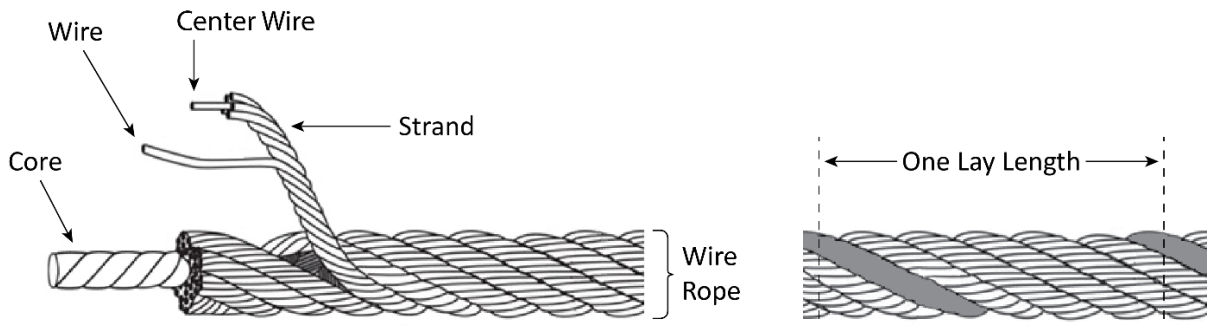

- Wire rope should be maintained in a well-lubricated condition at all times.

Wire rope is only fully protected when each wire strand is lubricated both internally and externally. Excessive wear shortens the life of wire rope. Use a wire-rope lubricant that penetrates to the core of the rope and provides long-term lubrication between each individual strand, such as 90-WT gear oil or ALMASOL® Wire Rope Lubricant. To make sure that the inner layers of the rope remain well lubricated, lubrication should be done at least every three months during normal operation.

- All Sheaves and guide rollers that contact moving wire rope should be given regular visual checks for surface wear and lubricated to make sure they run freely. This should be done every three months during normal operation.

For all sheave axles, use standard wheel bearing grease. For all Sheaves and/or guide rollers, use 90-WT gear oil or a similar heavy lubricant, applied by any method including pump/spray dispensing, brush, hand, or swabbing.

- How often should you inspect?

Wire rope should be visually inspected at least once each day when in use, as suggested by American Petroleum Institute's Recommended Practice 54 guidelines. Any wire rope that meets the criteria for removal must be immediately replaced.

- **When should you replace wire rope due to broken wires?**

Wire rope should be removed from service if you see six randomly distributed broken wires within any one lay length or three broken wires in one strand within one lay length.

- **Are there other reasons to replace your wire rope?**

Yes. Corrosion that pits the wires and/or connectors, evidence of kinking, crushing, cutting, bird-caging, or a popped core, wear that exceeds 10% of a wire's original diameter, or heat damage.

- **How do you find broken wires?**

- a. Relax your rope to a stationary position and move the pick-up points off the Sheaves. Clean the surface of the rope with a cloth — a wire brush, if necessary — so you can see any breaks.
- b. Flex the rope to expose any broken wires hidden in the valleys between the strands.
- c. Visually check for any broken wires. One way to check for crown breaks is to run a cloth along the rope to check for possible snags.
- d. With an awl, probe between wires and strands and raise any wires that appear loose.

Troubleshooting

This section describes how to troubleshoot your Lift.

NOTICE

If your Lift is not functioning correctly, you must take it out of service until it is fixed.

Important:

Replace worn, damaged or broken parts with original BendPak or BendPak approved parts or with parts that meet or exceed the original manufacturer specifications.

⚠ DANGER

Before performing maintenance on your Lift, verify it is disconnected from power. The Lift uses electrical energy; if your organization has Lockout/Tagout policies, implement them before performing any maintenance. If you come into contact with high voltage, you could be injured or killed.

Issue	Action to Take
Lift becomes inoperative in a raised position with vehicle.	Verify there is sufficient Hydraulic Fluid in the reservoir. Verify the Lift Carriages are above and clear of the Safety Locks. Verify none of the Hydraulic Hoses are pinched or leaking. Verify the Power Unit is getting power. Make sure the Lift is not overloaded. Make sure the load on the Lift is balanced. Contact bendpak.com/support . or by phone at (800) 253-2363 follow the prompts to reach service.
Arms move erratically or squeaks when in use.	Move the arms up and down a few times to flush any residual air from the Hydraulic System.
Lift does not stay up.	Check for Hydraulic Fluid leaks and Safety Lock function.
Vehicle on Lift not level.	Make sure Lift is engaged on Safety Locks <i>at the same height</i> . Make sure the Safety Locks in both Posts are engaged. If either condition is not met, carefully lower the Vehicle back down to the ground and raise it again. One of the Slack Safeties has engaged. Carefully disengage the Slack Safety that has engaged, lower the Lift to the ground, and have both Slack Safeties checked by a qualified technician or contact your dealer or BendPak Support. If behavior continues, check the Lifting Cables; adjust as necessary. If behavior still continues, contact BendPak Support.
Motor not running.	Check connection to power source; make sure it is plugged in and the appropriate voltage. Check the wiring diagram.

Hydraulic Fluid is dirty.	Replace the dirty Hydraulic Fluid with clean, approved ATF fluids, such as Dexron III, Dexron VI, Mercon V, Mercon LV, or comparable.
Lift makes odd noises.	Lubricate the insides of the four posts using white lithium or axle grease.

If you continue to have issues with your Lift, take the Lift out of service, then contact your dealer or BendPak Support at [bendpak.com/support](https://www.bendpak.com/support), via email at support@bendpak.com, or by phone at **(800) 253-2363**.

Wiring Diagrams

Power Unit

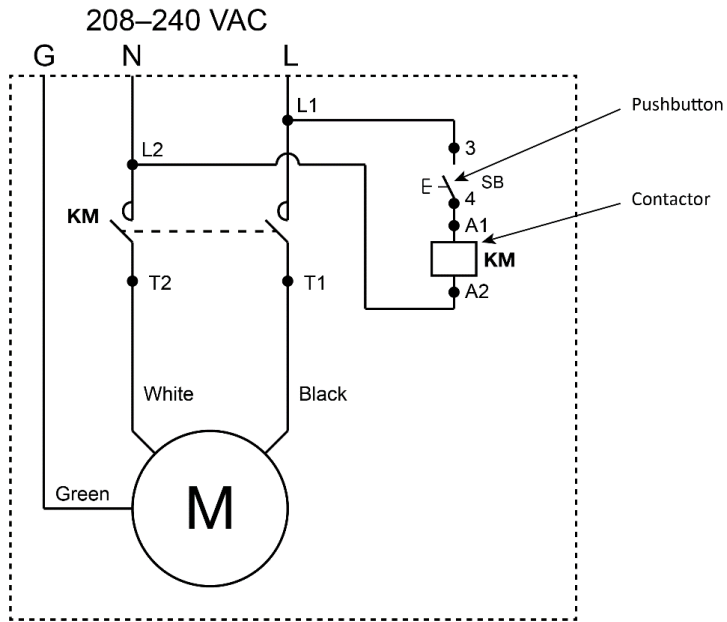

Microswitch

Top View

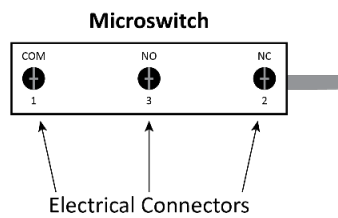

COM = Common
 NO = Normally Open
 NC = Normally Closed

Side View

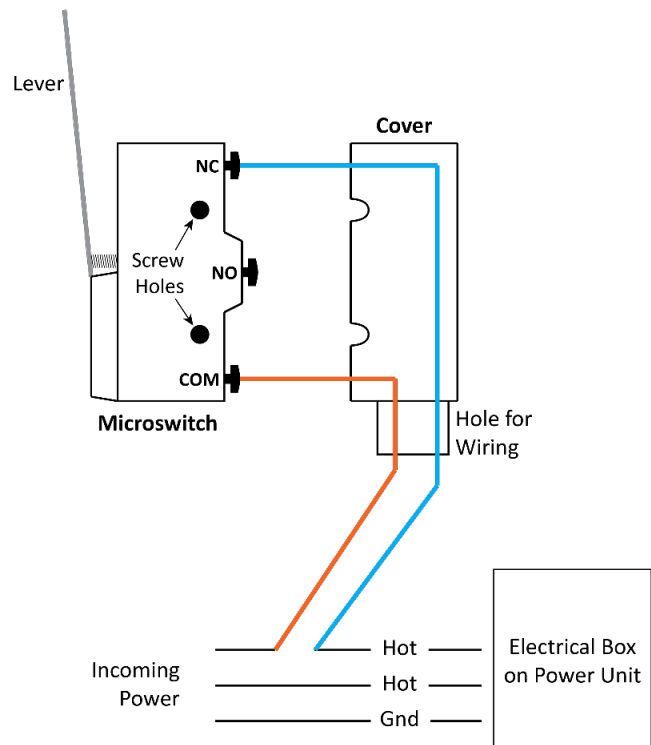

Parts Diagrams

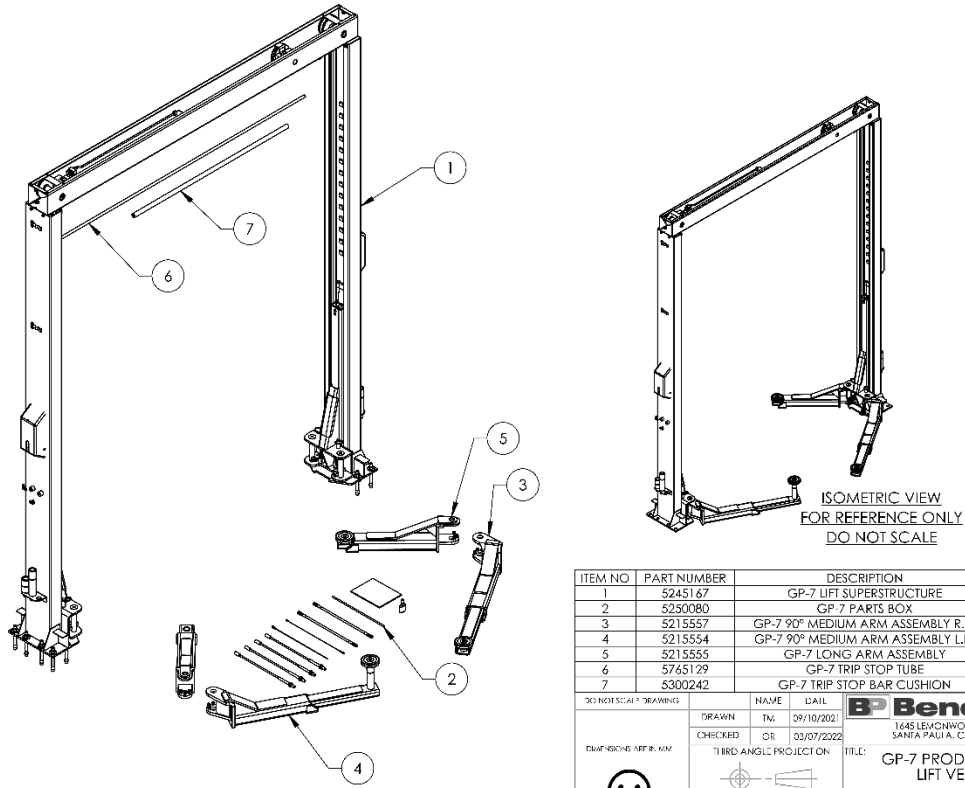

ITEM NO	PART NUMBER	DESCRIPTION	QTY	REV
1	5245167	GP-7 LIFT SUPERSTRUCTURE	1	B
2	5250080	GP-7 PARTS BOX	1	AF
3	5215557	GP-7 90° MEDIUM ARM ASSEMBLY R.H.	1	V
4	5215554	GP-7 90° MEDIUM ARM ASSEMBLY L.H.	1	V
5	5215555	GP-7 LONG ARM ASSEMBLY	2	U
6	5765129	GP-7 TRIP STOP TUBE	1	A
7	5300242	GP-7 TRIP STOP BAR CUSHION	1	B

30: NOT SCALE DRAWING	NAME	DATE	BendPak 1645 LEIGHWOOD DR. SANTA PAULA, CA 92660
	DRAWN	TM: 09/10/2021	
	CHECKED	DR: 03/07/2022	TITLE: GP-7 PRODUCTION LIFT VER B
EDWARDS-ARF B. KM	THIRD ANGLE PROJECTION		
	SIZE	DWG. NO.	REV
	A	5260660	C
SCALE: 1:30			SHEET 1 OF 3

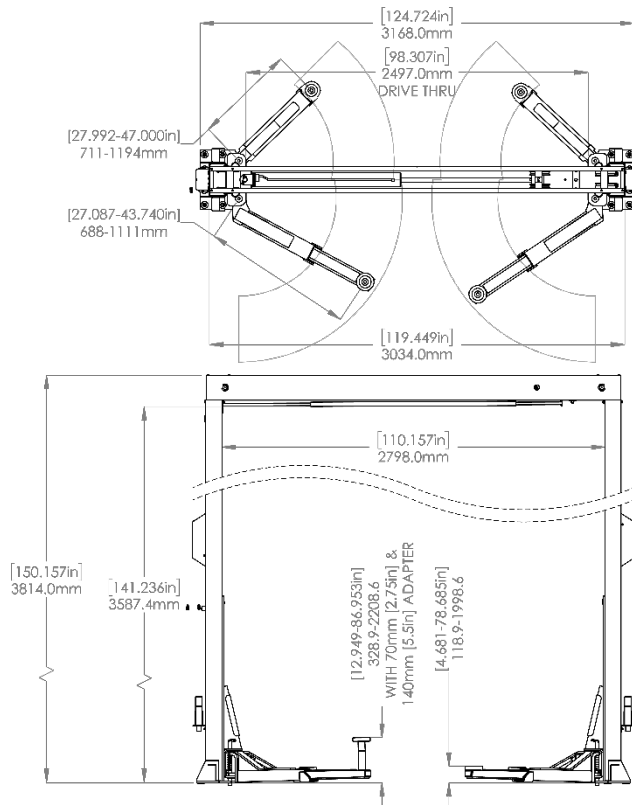

BendPak			
1645 LEIGHWOOD DR. SANTA PAULA, CA 92660			
TITLE: GP-7 PRODUCTION LIFT VER B			
SIZE	DWG. NO.	REV	
A	5260660	C	
SCALE: 1:30			SHEET 2 OF 3

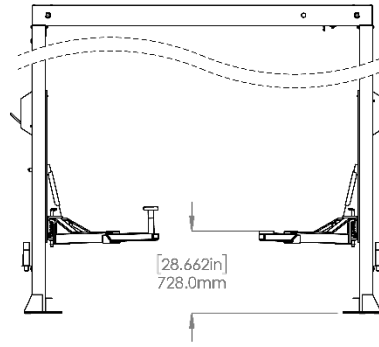

LOWEST LOCK

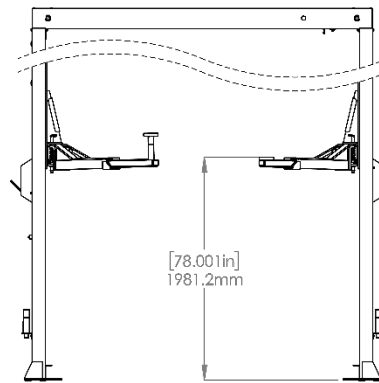

TOP LOCK

BP BendPak 1645 LEMONWOOD DR. SANTA PAULA, CA 95050			
TITLE: GP-7 PRODUCTION LIFT VER B			
SIZE	DWG. NO.	REV	
A	5260660	C	
SCALE: 1:40			SHEET 3 OF 3

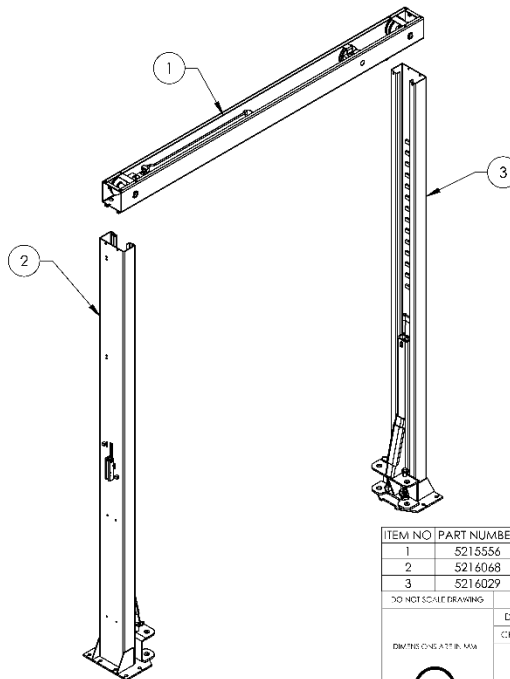
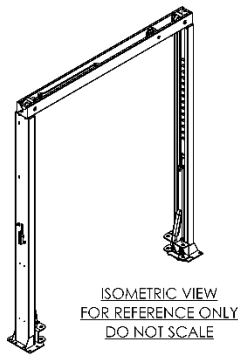

ITEM NO	PART NUMBER	DESCRIPTION	QTY	REV
1	5215556	GP-7 TOP TROUGH ASSEMBLY	1	R
2	5216068	GP-7 POWER POST ASSEMBLY	1	A
3	5216029	GP-7 OFF SIDE POST ASSEMBLY	1	A

DO NOT SCALE DRAWING		NAME	DATE	BP BendPak 1645 LEMONWOOD DR. SANTA PAULA, CA 95050
DRAWN	TM	09/09/2022		
CHECKED	CR	03/07/2022		TITLE: GP-7 LIFT SUPERSTRUCTURE
THIRD ANGLE PROJECTION				SIZE (DWG. NO.): A 5245167
				REV B
<small>PROPRIETARY AND CONFIDENTIAL THIS DRAWING IS THE PROPERTY OF BENDPAK INC. IT IS TO BE USED ONLY FOR THE PROJECT AND FOR THE QUANTITY OF BENDPAK INC. EQUIPMENT SPECIFICALLY IDENTIFIED THEREON. © 2022 BENDPAK INC.</small>				SCALE: 1:30 SHEET 1 OF 1

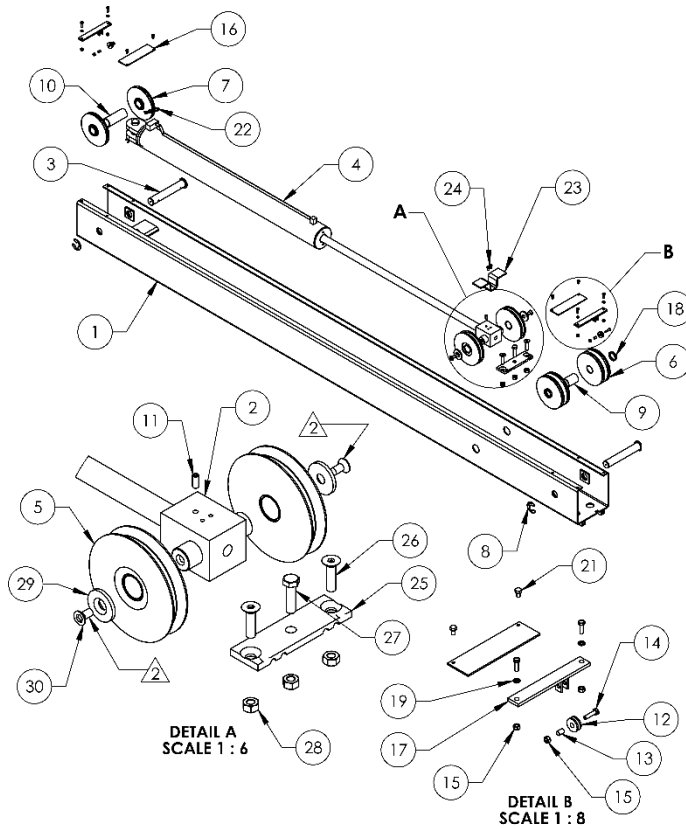

ITEM NO.	PART NUMBER	DESCRIPTION	QTY	REV
1	5600691	GP-7 TOP TROUGH WELDMENT	1	D
2	5601282	GP-7 CYLINDER PULL BLOCK WELDMENT	1	A
3	5600690	GP-7 POST SHEAVE PIN WELDMENT	2	B
4	5502214	CYLINDER ASSEMBLY Ø3.5 x 37 PULL CYLINDER	1	C
5	5215802	GP-7 SERIES PULL BLOCK TWIN SHEAVE ASSEMBLY	2	A
6	5216015	GP-7 TWIN SHEAVE ASSEMBLY, 48mm WIDE	2	A
7	5215549	GP-7 SERIES SHEAVE ASSEMBLY	2	D
8	5540010	E RING Ø32mm OD DIN 6799	2	--
9	5746521	GP-7 TWIN SHEAVE SPACER, 57mm LONG	1	A
10	5746283	GP-7 SHEAVE SPACER	1	C
11	5530239	SS M8 x 1.25 x 20	1	--
12	5575112	D2/GP/PCL/XPR/PL-7000 SAFETY SHEAVE	2	C
13	5565350	D2/GP/PCL/XPR/PL-7000 SAFETY SHEAVE SPACER	2	C
14	5530756	HHB M6 x 1.0 x 25mm	2	--
15	5535357	NUT M6 x 1.0 NL	6	--
16	5736519	GP-7 CABLE RETAINER PLATE	2	C
17	5600693	GP-7 SAFETY SHEAVE BRACKET PLATE WELDMENT	2	A
18	5746285	GP-7 TWIN SHEAVE SPACER, SHORT	2	B
19	5545005	WASHER, M6 x 12mm FLAT	4	--
20	5530093	HHB M6 x 1.0 x 20mm	4	--
21	5530181	HHB M6 x 1.0 x 10	4	--
22	5505350	HAIR PIN 1/8" x 2 9/16"	2	--
23	5701437	GP-7 PULL BLOCK SHEAVE RETAINER	1	C
24	5530031	HHB M6 x 1.0 x 12mm	2	--
25	5736533	GP-7 TOP TROUGH CABLE TIE PLATE, TOP	1	C
26	5530794	FHSS M12 x 1.75 x 45 CL10.9	2	--
27	5530792	HHB M12 x 1.75 x 45 CL10.9	1	--
28	5535041	NUT M12 x 1.75 NL CL10.9	3	--
29	5746466	GP-7 SERIES INNER SCISSOR BEARING SPACER	2	A
30	5530346	FHSS M10 x 1.5 x 20 CL10.9	2	--

DO NOT SCALE DRAWING

NAME	DATE	
DRAWN TM	06/06/2012	
CHECKED OR	03/07/2022	745 LEWIS WOOD DR. SANTA PAULA, CA 93060
THIRD ANGLE PROJECTION		TITLE: GP-7 TOP TROUGH ASSEMBLY
		SIZE DWG. NO. REV
		A 5215556 R
		SCALE: 1:20 SHEET 1 OF 1

REVISION				
REV	DESCRIPTION	DATE	EDITED BY	ECO#
M	ADDED (2) 5545200, 5580012, 5530093 (4) 5535357, AND (4) 5545005. REPLACED 5550100 WITH 5550147	02/07/2020	TM	01107
N	REPLACED 5550501 WITH 5550113, REMOVED (2) 5540015	10/01/2020	TM	01215
P	REPLACED 5550183 WITH 5550103, 5550550 WITH 5550106, 5550551 WITH 5550577, AND (2) 5530738 WITH 5530267. ADDED (2) 5535013 AND (2) 5530267. REMOVED 5530061	02/26/2021	CA	01273

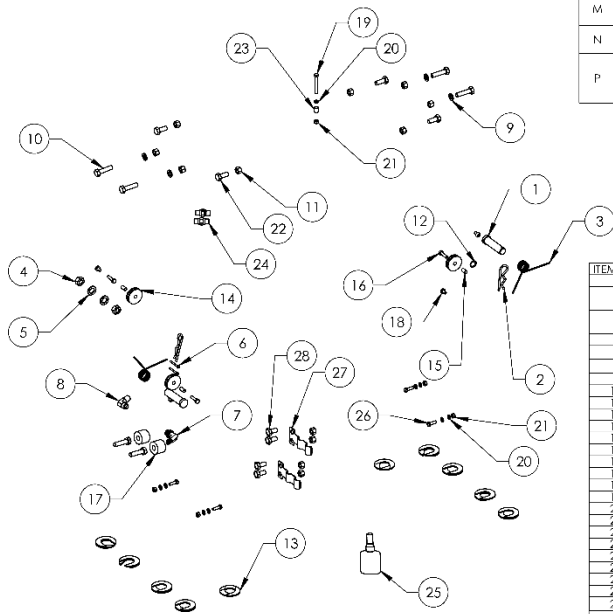

ITEM NO.	PART NUMBER	DESCRIPTION	QTY	REV
1	5505113	2 POST SAFETY CLEVIS PIN	2	H
2	5505350	MODEL#211 HAIR PIN/ LARGE	2	--
3	5540015	R.H., 2.5 WIRE DIA., Ø20.9 x 75 LG	2	--
4	5535357	NUT M12 x 1.75	1	--
5	5545347	WASHER, M12 FLAT WASHER	2	--
6	5530115	BIS 6-32 x 1.25	2	--
7	5550103	FTG ELB -04 JIC -08 ORB	1	--
8	5550106	FTG ELB -04 JIC x 3/8" NPT	1	--
9	5545200	WASHER M10 x Ø18 SL	6	--
10	5530302	HHB M10 x 1.5 x 40 FULLY THREAD	6	--
11	5530013	NUT M10 x 1.5 NL	12	--
12	5530031	ROTOR CLIP 12mm SS	1	--
13	5545355	C WASHER SHIM FOR LIFTS	20	--
14	5575107	Ø40mm SAFETY SHEAVE	3	A
15	5565125	GP-7 SAFETY SHEAVE SPACER, LONG	3	A
16	5530756	HHB M6 x 1.0 x 25	3	--
17	5575108	GP-7 SERIES POWER UNIT STANDOFF	2	A
18	5530261	PHPS M6 x 1.0 x 10	4	--
19	5530097	HHB M6 x 1.0 x 30	1	--
20	5545005	M6 FLAT WASHER	9	--
21	5535357	NUT M6 x 1.0 NL	5	--
22	5530738	HHB M10 x 1.5 x 25	4	--
23	5755135	D4-12, HD AIR CYLINDER SPACER 12mm	1	A
24	5550147	FTG NPL -04 JIC x -04 NPT	2	A
25	5580012	LIQUID PTFE THREAD SEALANT 50ml	1	--
26	5530093	HHB M6 x 1.0 x 20	4	--
27	5535077	DOUBLE PTFE STRAP Ø10mm	2	A
28	5530267	HHB, M10 x 1.5 x 20	4	--

DO NOT SCALE DRAWING

NAME	DATE	
DRAWN TM	05/19/2012	
CHECKED OR	02/22/2012	745 LEWIS WOOD DR. SANTA PAULA, CA 93060
THIRD ANGLE PROJECTION		TITLE: GP-7 PARTS BAG
		SIZE DWG. NO. REV
		A 5174660 P
		SCALE: 1:10 SHEET 1 OF 1

REVISION				
REV	DESCRIPTION	DATE	EDITED BY	ECO#
AD	UPDATED BOM REVISION	10/01/2020	TM	01215
AE	REPLACED 5570195 WITH 5570248, UPDATED BOM REVISION	02/18/2021	CA	01273
AF	UPDATED BOM REVISIONS	01/11/2022	CA	01371

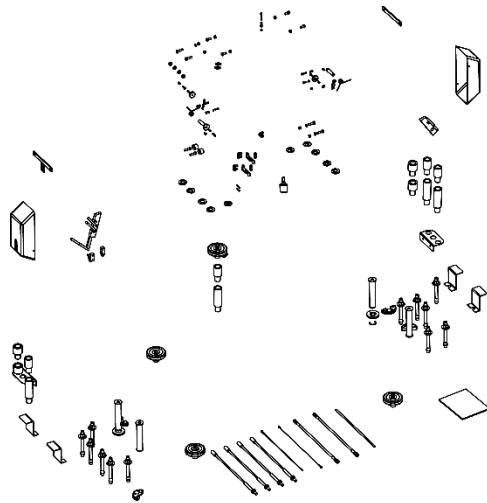

ITEM NO	PART NUMBER	DESCRIPTION	QTY	REV
1	5174660	GP 7 PARTS BAG	1	P
2	5736604	TWO POST LIGHT DUTY BOLT ON ARM RESTRAINT GEAR	4	E
3	5505040	GP-7 LIFT HEAD PIN WELDMENT	4	E
4	5540281	C RING Ø38mm OD 5103-150	4	A
5	5210245	GP-7 OFF SIDE SAFETY LATCH WELDMENT	1	D
6	5210240	GP-7 POWER SIDE SAFETY LATCH WELDMENT	1	H
7	5215507	ROUND LIFT PAD ADAPTER ASSEMBLY	4	G
8	5746389	SHORT LIFT PAD EXTENSION (95mm LG.)	4	C
9	5746390	MEDIUM LIFT PAD EXTENSION Ø35 x 113mm	4	E
10	5746395	LONG LIFT PAD EXTENSION Ø35 x 182mm	4	D
11	5525112	MICRO SWITCH COVER 5PA2	1	-
12	5525150	SPDT MICRO SWITCH:25A@125VAC	1	-
13	5595414	CABLE ASSEMBLY Ø10 x 6405mm ST (16)	2	D
14	5595463	CABLE ASSEMBLY Ø10 x 3425mm ST (16)	2	C
15	5595446	GP-7 Ø2.4 x 7298mm SAFETY CABLE	1	A
16	5595548	GP-7 Ø1.2 x 1907mm MICRO SWITCH CABLE	1	B
17	5570248	HYDRAULIC HOSE ASSEMBLY Ø6.35 x 2821mm DS	2	A
18	5520116	14-4 SJO IUL 62 CABLE 300vac	610mm*	-
19	5530337	AB 3/4" x 6.3"	12	-
20	5716173	D2-8/12/15, GP/XPR POWER SIDE PLASTIC SAFETY COVER	1	B
21	5716174	D2-8/12/15, GP/XPR OFF SIDE PLASTIC SAFETY COVER	1	B
22	5746393	GP-7 ARM SPACER	2	E
23	5600718	GP-7 POST STRAP WELDMENT	1	A
24	5734493	GP-7 POST STRAP	1	A
25	5900209	GP-7 SERIES INSTALLATION MANUAL	1	-
26	5701665	D2-8F, GP-7 HEIGHT ADAPTER HOLDER	2	A
27	5730663	GP-7 POST ASSEMBLY LIFT HEAD FOOT GUARD R.H.	2	H
28	5730664	GP-7 POST ASSEMBLY LIFT HEAD FOOT GUARD L.H.	2	H

JO: B.O. SCALE: DRAW NOS. NAME: DATE: **BendPak**
 DRAWN: TM 06/19/2012 1645 LEMONWOOD DR.
 CHECKED: C. ICKED SANTA PAULA, CA 93060
 DIMENSIONS ARE IN MM TITLE: GP-7 PARTS BOX
 THIRD ANGLE PROJECTION
 PROPRIETARY AND CONFIDENTIAL
 THIS DOCUMENT IS THE PROPERTY OF BENDPAK INC. ANY
 REPRODUCTION OR MENTION OF BENDPAK INC. IN
 ANY MANNER WITHOUT THE WRITTEN PERMISSION OF
 BENDPAK INC. IS STRICTLY PROHIBITED.
 SIZE DWG. NO. REV
A 5250080 AF
 SCALE: 1:30 SHEET 1 OF 2

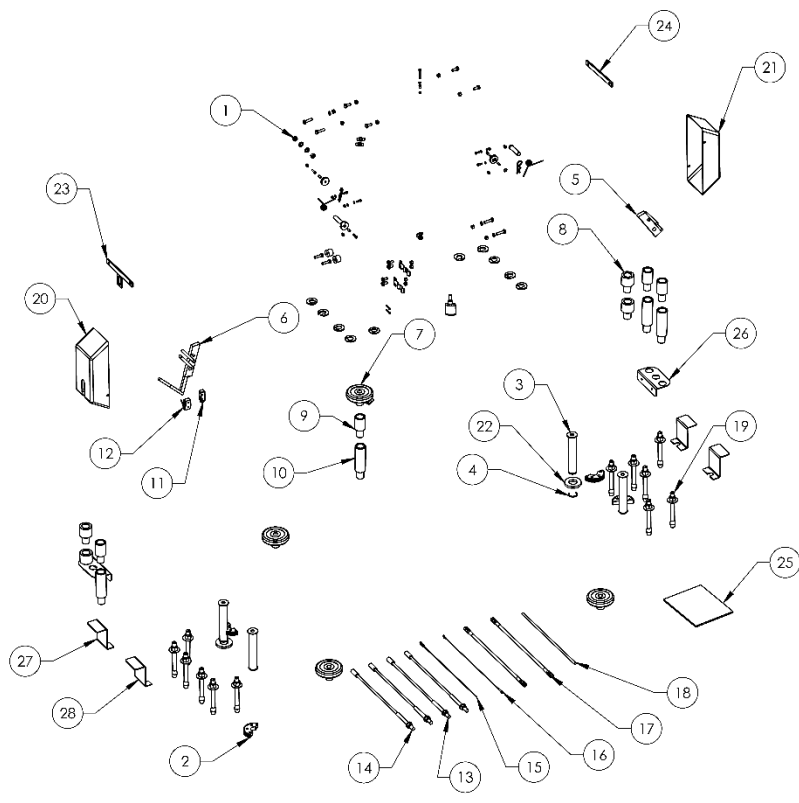

BendPak
 1645 LEMONWOOD DR.
 SANTA PAULA, CA 93060
 TITLE: GP-7 PARTS BOX
 SIZE DWG. NO. REV
A 5250080 AF
 SCALE: 1:20 SHEET 2 OF 2

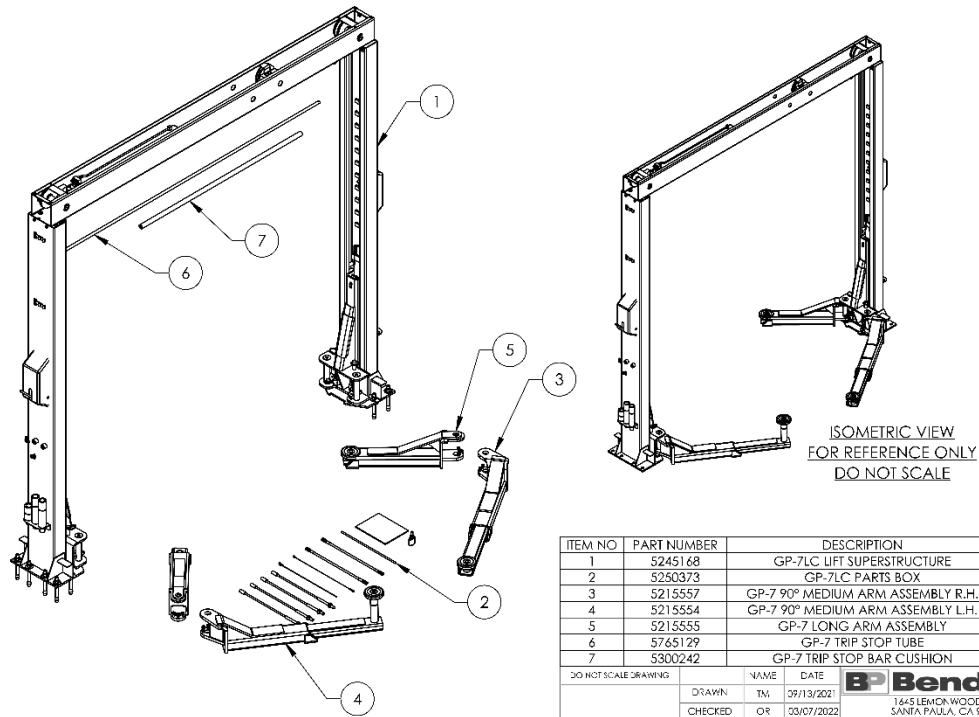

ITEM NO	PART NUMBER	DESCRIPTION	QTY	REV
1	5245168	GP-7LC LIFT SUPERSTRUCTURE	1	B
2	5250373	GP-7LC PARTS BOX	1	T
3	5215557	GP-7 90° MEDIUM ARM ASSEMBLY R.H.	1	V
4	5215554	GP-7 90° MEDIUM ARM ASSEMBLY L.H.	1	V
5	5215555	GP-7 LONG ARM ASSEMBLY	2	U
6	5765129	GP-7 TRIP STOP TUBE	1	A
7	5300242	GP-7 TRIP STOP BAR CUSHION	1	B

DO NOT SCALE DRAWING		NAME	DATE	 1445 LEMONWOOD DR. SANTA PAULA, CA 93060
DRAWN	TM	09/13/2021		
CHECKED	OR	03/07/2022		TITLE:
THIRD ANGLE PROJECTION				GP-7LC PRODUCTION LIFT VER B
				SIZE: DWG. NO.
				A 5260661 C
<small> PROPRIETARY AND CONFIDENTIAL THE INFORMATION CONTAINED HEREIN IS SOLELY FOR THE USE OF THE CUSTOMER AND IS NOT TO BE REPRODUCED OR TRANSMITTED IN ANY FORM OR BY ANY MEANS, ELECTRONIC OR MECHANICAL, INCLUDING PHOTOCOPYING, RECORDING, OR BY ANY INFORMATION STORAGE AND RETRIEVAL SYSTEM, WITHOUT THE WRITTEN PERMISSION OF BENDPAK INC. © 2021 BENDPAK INC. </small>				SCALE: 1:30 SHEET 1 OF 3

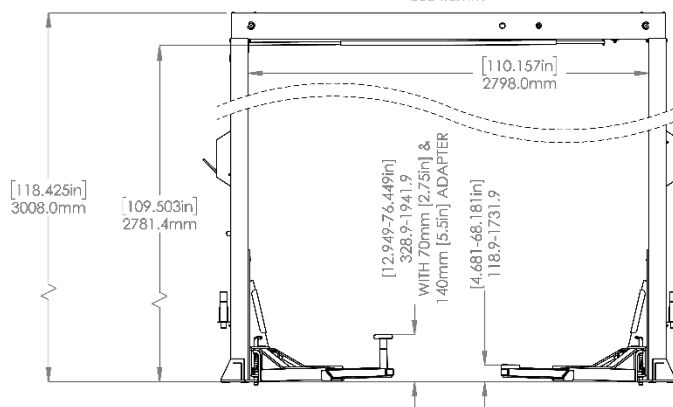
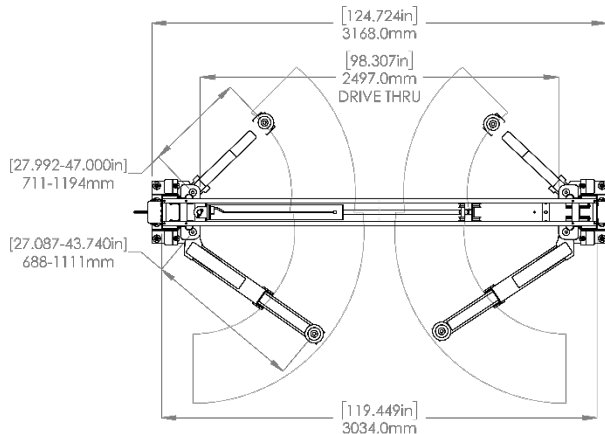

 1445 LEMONWOOD DR. SANTA PAULA, CA 93060	
TITLE:	
GP-7LC PRODUCTION LIFT VER B	
SIZE: DWG. NO.	REV:
A 5260661	C
SCALE: 1:30 SHEET 2 OF 3	

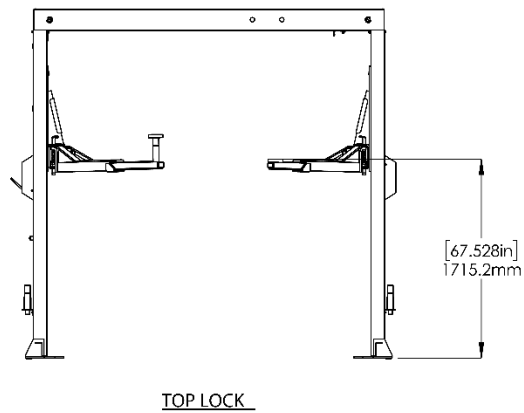
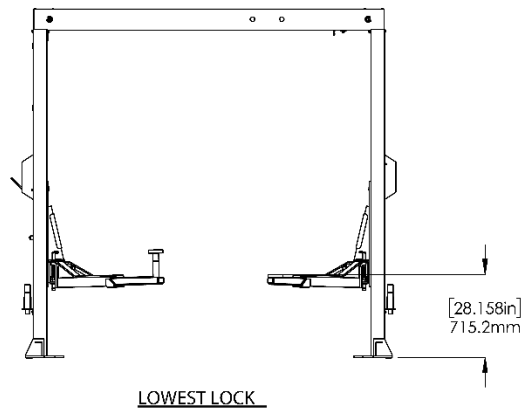

BP BendPak
 1645 LEMONWOOD DR.
 SANTA PAULA, CA 93060

TITLE: GP-7LC PRODUCTION LIFT VER B

SIZE DWG. NO. REV
A 5260661 C

SCALE: 1:40 SHEET 3 OF 3

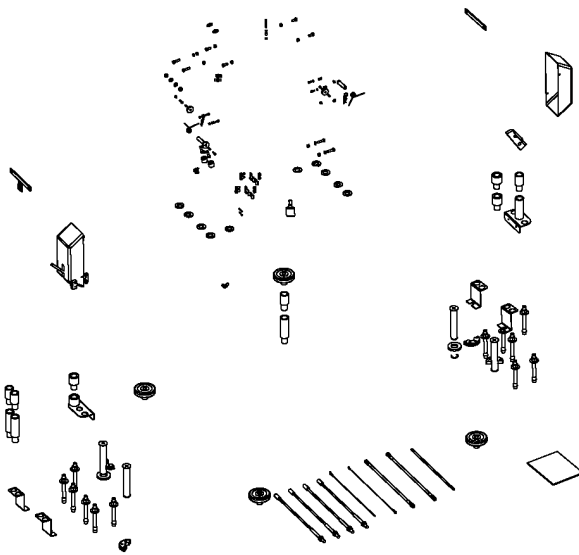

ITEM NO	PART NUMBER	DESCRIPTION	QTY	REV
1	5174660	GP-7 PARTS BAG	1	P
2	5736604	TWO POST LIGHT DUTY BOLT ON ARM RESTRAINT GEAR	4	E
3	5505040	GP-7 LIFT HEAD PIN WELDMENT	4	E
4	5540281	C RING Ø38mm OD 5103-150	4	-
5	5210245	GP-7 OFF SIDE SAFETY LATCH WELDMENT	1	D
6	5210240	GP-7 POWER SIDE SAFETY LATCH WELDMENT	1	H
7	5215507	ROUND LIFT PAD ADAPTER ASSEMBLY	4	G
8	5746389	SHORT LIFT PAD EXTENSION (95mm LG.)	4	C
9	5746390	MEDIUM LIFT PAD EXTENSION Ø35 x 113mm	4	E
10	5746395	LONG LIFT PAD EXTENSION Ø35 x 182mm	4	D
11	5730664	GP-7 POST ASSEMBLY LIFT HEAD FOOT GUARD L.H.	2	G
12	5730663	GP-7 POST ASSEMBLY LIFT HEAD FOOT GUARD R.H.	2	G
13	5525112	MICRO SWITCH COVER-5PA2	1	-
14	5525150	SPDT MICRO SWITCH;25A@125VAC	1	-
15	5595932	GP-7LC CABLE ASSEMBLY Ø10 x 6566mm ST	2	C
16	5595934	GP-7LC CABLE ASSEMBLY Ø10 x 3575mm ST	2	C
17	5595933	GP-7LC Ø2.4 x 6614mm SAFETY CABLE	1	A
18	5595550	GP-7LC Ø1.2 x 1320mm MICRO SWITCH CABLE	1	C
19	5570249	HYDRAULIC HOSE ASSEMBLY Ø6.35 x 2228mm DS	2	A
20	5520116	14-4 SJO UL 62 CABLE 300vac	400mm*	-
21	5530337	AB 3/4" x 6.3"	12	-
22	5716173	D2-8/12/15, GP/XPR POWER SIDE PLASTIC SAFETY COVER	1	B
23	5716174	D2-8/12/15, GP/XPR OFF SIDE PLASTIC SAFETY COVER	1	B
24	5746293	GP-7 ARM SPACER	2	E
25	5600718	GP-7 POST STRAP WELDMENT	1	A
26	5736493	GP-7 POST STRAP	1	A
27	5900209	GP-7 SERIES INSTALLATION MANUAL	1	-
28	5701665	D2-8F, GP-7 HEIGHT ADAPTER HOLDER	2	A

DO NOT SCALE DRAWING

NAME DATE
 DRAWN TS 05/22/2017

CHECKED

THIRD ANGLE PROJECTION

PROPRIETARY AND CONFIDENTIAL
 THE INFORMATION CONTAINED IN THIS DRAWING IS THE SOLE PROPERTY OF BENDPAK, INC. ANY REPRODUCTION IN PART OR AS A WHOLE WITHOUT THE WRITTEN PERMISSION OF BENDPAK, INC. IS PROHIBITED.

BP BendPak
 1645 LEMONWOOD DR.
 SANTA PAULA, CA 93060

TITLE: GP-7LC PARTS BOX

SIZE DWG. NO. REV
A 5250373 R

SCALE: 1:30 SHEET 1 OF 2

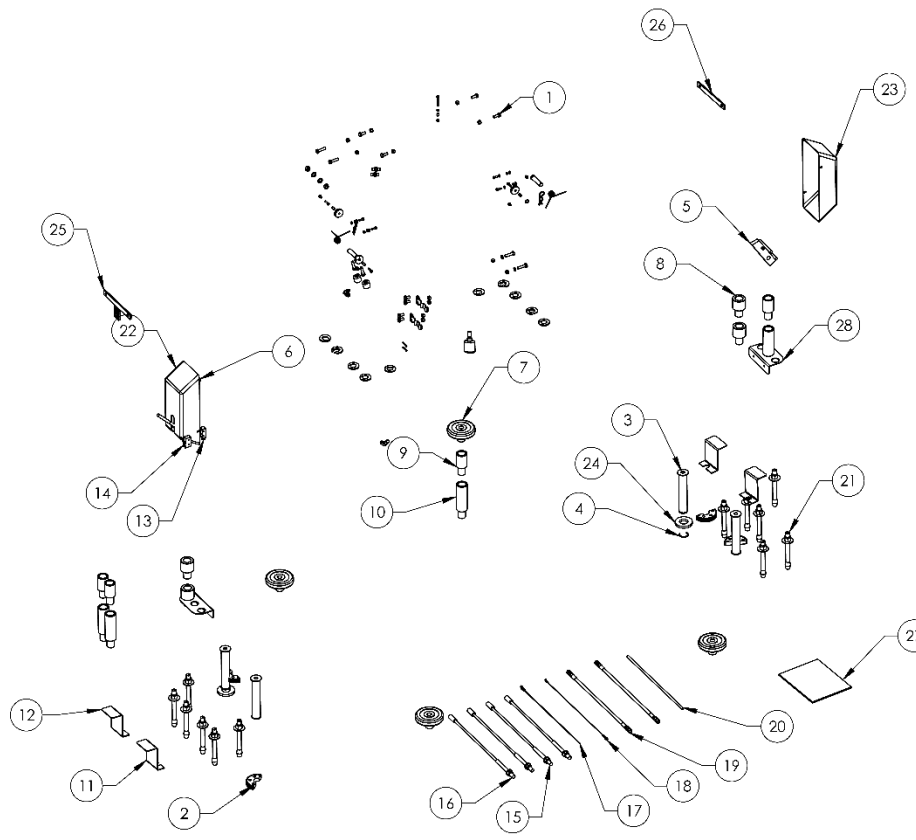

BendPak
 1645 ELMONWOOD DR.
 SANTA PAULA, CA 93060

TITLE:
 GP-7LCS PARTS BOX

SIZE	DWG. NO.	REV
A	5250373	T

SCALE: 1:20 SHEET 2 OF 2

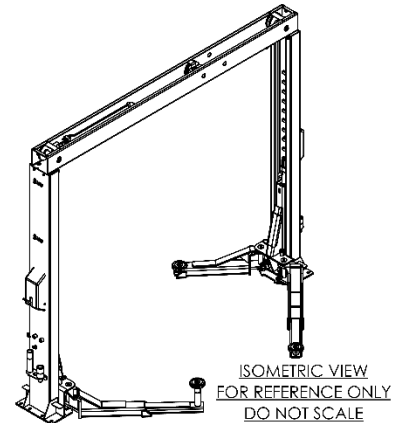
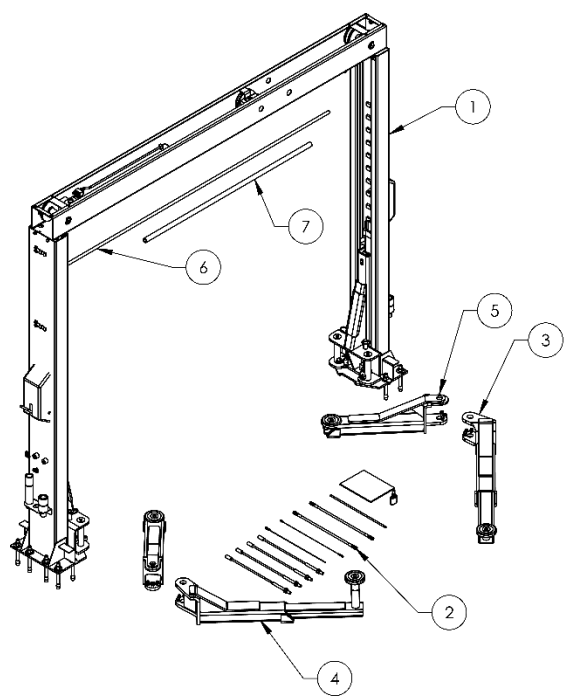

ITEM NO	PART NUMBER	DESCRIPTION	QTY	REV
1	5245169	GP-7LCS LIFT SUPERSTRUCTURE	1	B
2	5250374	GP-7LCS PARTS BOX	1	T
3	5215557	GP-7 90° MEDIUM ARM ASSEMBLY R.H.	1	V
4	5215554	GP-7 90° MEDIUM ARM ASSEMBLY L.H.	1	V
5	5215555	GP-7 LONG ARM ASSEMBLY	2	U
6	5765129	GP-7 TRIP STOP TUBE	1	A
7	5300242	GP-7 TRIP STOP BAR CUSHION	1	B

DO NOT SCALE DRAWING	NAME	DATE	BendPak 1645 ELMONWOOD DR. SANTA PAULA, CA 93060
DRAWN	TM	09/13/2021	
CHECKED	OR	03/07/2022	TITLE: GP-7LCS PRODUCTION LIFT VER B
THIRD ANGLE PROJECTION			SIZE DWG. NO. REV
			A 5260662 C
<small>PROPRIETARY AND CONFIDENTIAL THIS INFORMATION IS THE PROPERTY OF BENDPAK INC. ALL RIGHTS RESERVED. NO PART OF THIS PUBLICATION MAY BE REPRODUCED OR TRANSMITTED IN ANY FORM OR BY ANY MEANS WITHOUT THE WRITTEN PERMISSION OF BENDPAK INC. © 2022</small>			SCALE: 1:30 SHEET 1 OF 3

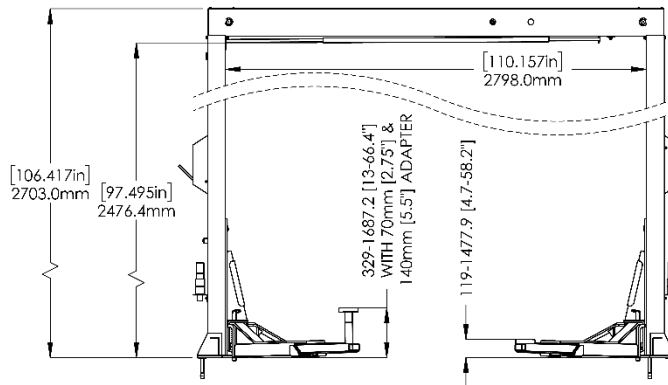
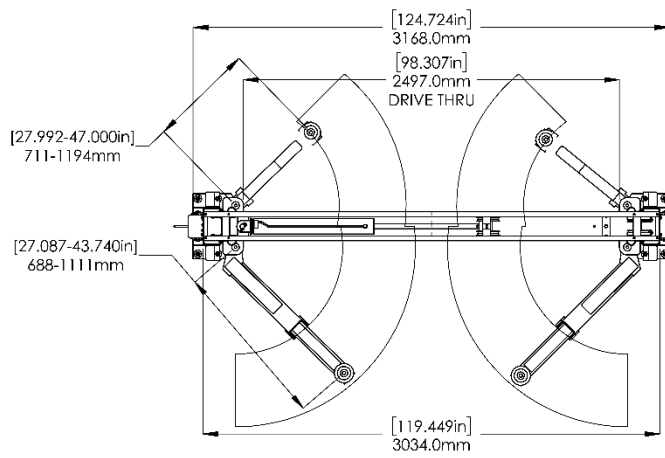

BendPak	
1645 LEMONWOOD DR. SANTA PAULA, CA 93060	
TITLE: GP-7LCS PRODUCTION LIFT VER B	
SIZE (DWG. NO.)	REV
A 5260662	C
SCALE: 1:30 SHEET 2 OF 3	

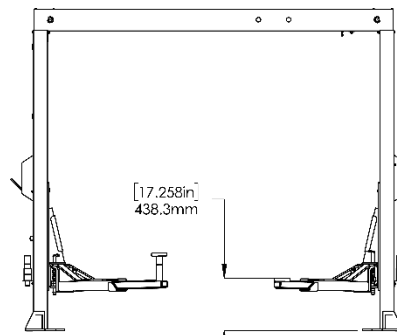

LOWEST LOCK

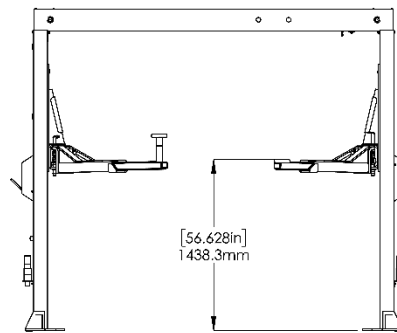

TOP LOCK

BendPak	
1645 LEMONWOOD DR. SANTA PAULA, CA 93060	
TITLE: GP-7LCS PRODUCTION LIFT VER B	
SIZE (DWG. NO.)	REV
A 5260662	C
SCALE: 1:35 SHEET 3 OF 3	

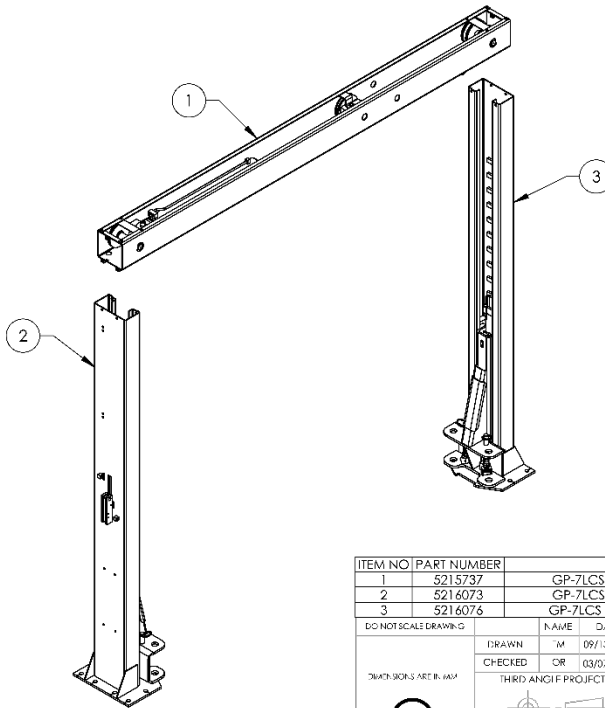
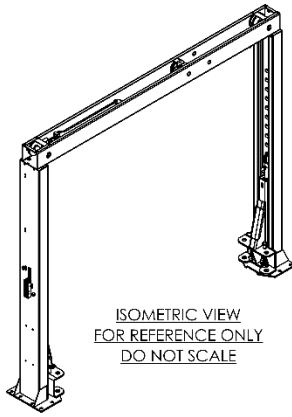

ITEM NO	PART NUMBER	DESCRIPTION	QTY	REV
1	5215737	GP-7LCS TOP TROUGH ASSEMBLY	1	K
2	5216073	GP-7LCS POWER POST ASSEMBLY	1	A
3	5216076	GP-7LCS OFF SIDE POST ASSEMBLY	1	A

DO NOT SCALE DRAWING		NAME	DATE	 BendPak 1645 LEMONWOOD DR. SANTA PAULA, CA 93360
DRAWN	TM	09/13/2021		
CHECKED	CR	03/07/2022		
THIRD ANGLE PROJECTION			TITLE:	
				TITLE: GP-7LCS LIFT SUPERSTRUCTURE SIZE: DWG. NO. 5245169 REV B SCALE: 1:25 SHEET 1 OF 1

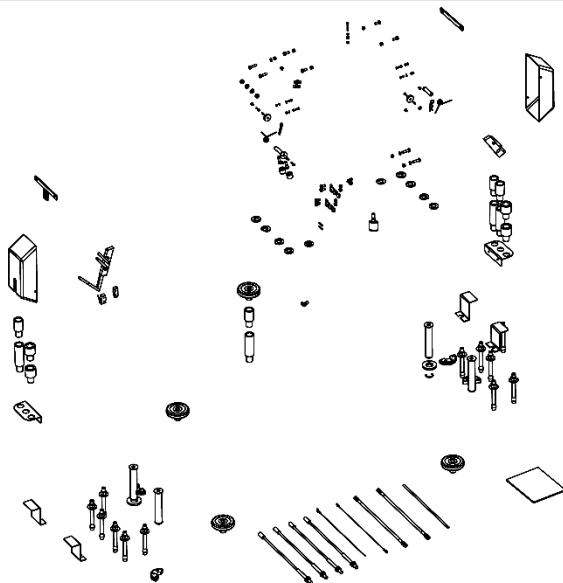

ITEM NO	PART NUMBER	DESCRIPTION	QTY	REV
1	5174660	GP-7 PARTS BAG	1	P
2	5736604	TWO POST LIGHT DUTY BOLT ON ARM RESTRAINT GEAR	4	E
3	5505040	GP-7 LIFT HEAD PIN WELDMENT	4	E
4	5540281	C RING Ø38mm OD 5103-150	4	-
5	5210245	GP-7 OFF SIDE SAFETY LATCH WELDMENT	1	D
6	5210240	GP-7 POWER SIDE SAFETY LATCH WELDMENT	1	H
7	5215507	ROUND LIFT PAD ADAPTER ASSEMBLY	4	G
8	5746389	SHORT LIFT PAD EXTENSION (95mm LG.)	4	C
9	5746390	MEDIUM LIFT PAD EXTENSION Ø35 x 113mm	4	E
10	5746395	LONG LIFT PAD EXTENSION Ø35 x 182mm	4	D
11	5730664	GP-7 POST ASSEMBLY LIFT HEAD FOOT GUARD L.H.	2	H
12	5730663	GP-7 POST ASSEMBLY LIFT HEAD FOOT GUARD R.H.	2	H
13	5525112	MICRO SWITCH COVER-5PA2	1	-
14	5525150	SPDT MICRO SWITCH:25A@125VAC	1	-
15	5595936	GP-7LCS CABLE ASSEMBLY Ø10 x 6782mm ST	2	D
16	5595938	GP-7LCS CABLE ASSEMBLY Ø10 x 3785mm ST	2	D
17	5595937	GP-7LCS Ø2.4 x 6556mm SAFETY CABLE	1	A
18	5595551	GP-7LCS Ø1.2 x 1291mm MICRO SWITCH CABLE	1	F
19	5570250	HYDRAULIC HOSE ASSEMBLY Ø6.35 x 2192mm DS	2	A
20	5520116	14-4 SJO UL 62 CABLE 300vac	610mm*	-
21	5530337	AB 3/4" x 6.3"	12	-
22	5716173	D2-8/12/15, GP/XPR POWER SIDE PLASTIC SAFETY COVER	1	B
23	5716174	D2-8/12/15, GP/XPR OFF SIDE PLASTIC SAFETY COVER	1	B
24	5746293	GP-7 ARM SPACER	2	E
25	5600718	GP-7 POST STRAP WELDMENT	1	A
26	5736493	GP-7 POST STRAP	1	A
27	5900209	GP-7 SERIES INSTALLATION MANUAL	1	-
28	5701665	D2-8F, GP-7 HEIGHT ADAPTER HOLDER	2	A

DO NOT SCALE DRAWING		NAME	DATE	 BendPak 1645 LEMONWOOD DR. SANTA PAULA, CA 93360
DRAWN	TM	06/14/2017		
CHECKED				
THIRD ANGLE PROJECTION			TITLE:	
				TITLE: GP-7LCS PARTS BOX SIZE: DWG. NO. 5250374 REV T SCALE: 1:30 SHEET 1 OF 2

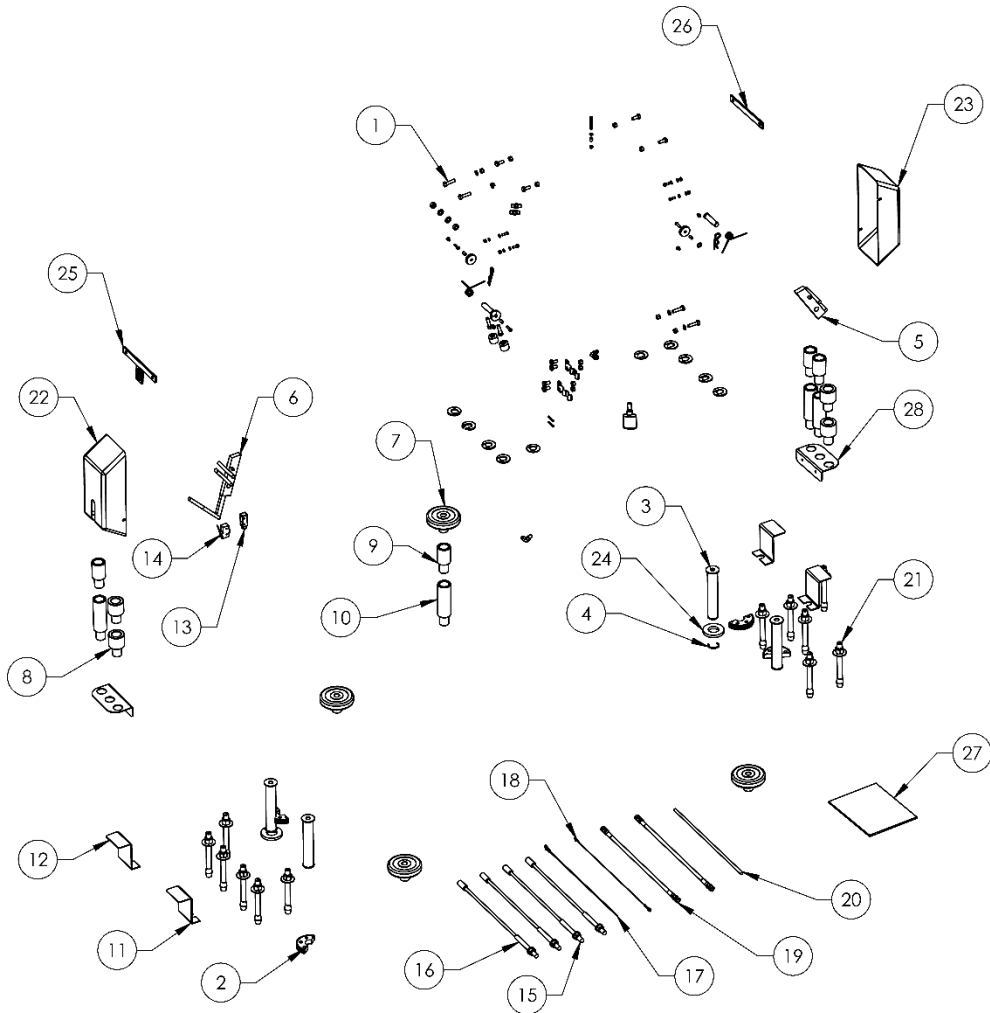

BP BendPak.		
1645 LEMONWOOD DR. SANTA PAULA, CA 93060		
TITLE: GP-7LCS PARTS BOX		
SIZE	DWG. NO.	REV
A	5250374	T
SCALE: 1:20		SHEET 2 OF 2

Labels



GRANDPRIX

1611 Lakeshore Drive
Tampa, FL, CA 33602
USA
888.852.9979
www.grandprix.com

A

B



C



SANTA PAULA, CA USA
WWW.BENDPAK.COM

LIFT TYPE: SURFACE MOUNT CAP: MED-HYV DTY MFG. BPK SEE DATA PLATE FOR PRODUCT DETAILS
POWER: ELECTRIC/HYDRAULIC INSTALLATION - SEE OWNERS GUIDE OR CONTACT FACTORY

SAFETY INSTRUCTIONS: IF ATTACHMENTS, ACCESSORIES OR CONFIGURATION MODIFYING COMPONENTS THAT ARE LOCATED IN THE LOAD PATH, AFFECT OPERATION OF THE LIFT, AFFECT THE LIFT ELECTRICAL LISTING OR AFFECT INTENDED VEHICLE ACCOMMODATION USED ON THIS LIFT AND, IF THEY ARE NOT CERTIFIED FOR USE ON THIS LIFT, THEN THE CERTIFICATION OF THIS LIFT SHALL BECOME NULL AND VOID. CONTACT THE PARTICIPANT FOR INFORMATION PERTAINING TO CERTIFIED ATTACHMENTS, ACCESSORIES OR CONFIGURATION MODIFYING COMPONENTS.

BENDPAK LIFTS ARE SUPPLIED WITH CONCRETE FASTENERS MEETING THE CRITERIA AS PRESCRIBED BY ASTM F488 - 06(2009). LIFT BUYERS ARE RESPONSIBLE FOR ANY SPECIAL, REGIONAL, STRUCTURAL AND/OR SEISMIC ANCHORING REQUIREMENTS SPECIFIED BY ANY OTHER AGENCIES AND/OR CODES SUCH AS THE UNIFORM BUILDING CODE (UBC) AND/OR INTERNATIONAL BUILDING CODE (IBC).

THE MANUFACTURE, USE, SALE OR IMPORT OF THIS PRODUCT MAY BE SUBJECT TO ONE OR MORE UNITED STATES PATENTS, OR PENDING APPLICATIONS, OWNED BY BENDPAK INC.
DO NOT REMOVE ENGINEERED BY BENDPAK INC. USA MADE IN CHINA

D

ATTENTION

MAXIMUM LIFTING CAPACITY
CAPACITÉ DE LEVAGE MAXIMUM

7000 Lbs.

3175 Kg.

PN 590045

E

F

WARNING

USE PROPER ADAPTERS

Do not attempt to lift trucks or other frame type vehicles with standard rubber contact pads. NEVER use lift with missing or damaged rubber contact pads. ALWAYS use lift with rubber contact pads when worn or damaged. Contact BendPak or your BendPak dealer for product information.

ATTENTION

UTILISEZ DES ADAPTEURS APPROPRIÉS

N'essayez pas de soulever des camions ou d'autres véhicules de type châssis avec des patins de contact en caoutchouc standard. NE JAMAIS utiliser d'adaptateur avec des plots de contact en caoutchouc manquants ou endommagés. REMPLACEZ TOUJOURS les plots de contact en caoutchouc lorsqu'ils sont usés ou endommagés. Contactez BendPak ou votre revendeur BendPak pour obtenir des informations sur le produit.

**FRAME CRADLE ADAPTERS
ADAPTEURS DE CADRE DE CADRE**
SKU# 521255

Required for use when lifting trucks, vans or other frame vehicles that require additional stability.
Requis pour une utilisation les véhicules à châssis qui nécessitent une stabilité supplémentaire.

**SUN & VAN ADAPTERS
ADAPTEURS BUS ET VAN**

52 mm SKU# 524903
70 mm SKU# 524390
140 mm SKU# 524235

Roomed for trucks, SUVs and vans that require additional lifting height. Rooming for trucks, SUVs and vans that require additional lifting height.

**STEEL LIFT PADS
TAMPOURS DE LEVAGE EN ACIER**
SKU# 525045

Steel lift pads are recommended for additional stability or additional height. The height edge of the chassis for an extra secure lift.
Des tampons de levage en acier sont recommandés pour une stabilité supplémentaire ou une hauteur de levage accrue.

REPLACEMENT POLYURETHANE TUF PADS™
REEMPLACEMENT POLYURETHANE TUF PADS™
SKU# 521517

NEVER use lift with missing or damaged rubber contact pads. ALWAYS REPLACE rubber contact pads when worn or damaged. NE JAMAIS utiliser d'adaptateur avec des plots de contact en caoutchouc manquants ou endommagés. TOUJOURS REMPLACEZ les plots de contact en caoutchouc lorsqu'ils sont usés ou endommagés.

TO PLACE ORDER
Visit www.bendpak.com or dial 1-800-933-9970
Monday - Friday 9 a.m. - 4:30 p.m. PST

POUR COMMANDER
Visitez www.bendpak.com ou composez 1-800-933-9970
Lundi - Vendredi 9h du matin - 4h30 TP

- TO RAISE LIFT:**
1. Press and hold UP button.
 2. When lift is just PAST desired height, release UP button.
 3. Hold down Lowering Handle. DO NOT hold down Safety Lock Release Handle. Lift engages on safety locks.
 4. Release Lowering Handle.

- TO LOWER LIFT:**
1. Press and hold UP button for two to three seconds, moving lift off safety locks.
 2. Hold down Safety Lock Release Handle and Lowering Handle.
 3. When lift is fully lowered, release both handles.

G

DANGER

THE MAXIMUM LIFTING CAPACITY FOR THIS LIFT IS DESCRIBED BELOW

Maximum Lifting Capacity 7,000 lbs. / 3,175 kg
Max. Lifting Cap. / Front of Lift Center 3,500 lbs. / 1,588 kg
Max. Lifting Cap. / Rear of Lift Center 3,500 lbs. / 1,588 kg

Exceeding the weight capacity of this lift can damage lift and/or property and may cause personal harm, injury or death to operators and/or bystanders. All vehicles MUST be positioned on lift with CENTER OF GRAVITY midway between adapters and/or centered on runways. Damage to lift due to re-tilting or misuse IS NOT covered under warranty.

LA CAPACITÉ DE LEVAGE MAXIMUM POUR DE LEVAGE EST DÉCRIT CI-DESSOUS

Capacité de Levage Maximale 7,000 lbs. / 3,175 kg
Max. Capacité de Levage, / Avant du centre de rétroviseur 3,500 lbs. / 1,588 kg
Max. Capacité de Levage, / Arrière du centre de levage 3,500 lbs. / 1,588 kg

Le dépassement de la capacité de poids de cet élévateur peut endommager l'élevateur et/ou les biens et peut causer des dommages corporels, des blessures voire la mort aux opérateurs et/ou aux passagers. Tous les véhicules DOIVENT être placés sur l'élevateur avec le CENTRE DE GRAVITÉ à mi-chemin entre les adaptateurs et/ou au centre des pistes. Les dommages à soulever dus à la surcharge ou une mauvaise utilisation N'EST PAS couvert par la garantie.

IMPORTANT

OPERATION / MAINTENANCE INSTRUCTIONS - PLEASE READ
INSTRUCTIONS D'UTILISATION / D'ENTRETIEN - VOULEZ LIRE

DANGER

Long wheelbase vehicles can damage lift under certain product uses or lifts to operations. Do not attempt to lift vehicles with wheelbases longer than 100" (2540 mm) on lifts with a center of gravity midway between adapters. Les véhicules à empattement plus long peuvent endommager le pont élévateur et/ou causer des blessures ou des dommages corporels, des blessures voire la mort aux opérateurs et/ou aux passagers. NE JAMAIS utiliser des véhicules avec un empattement plus long que 100" (2540 mm) sur des élévateurs à centre de gravité au milieu des adaptateurs.

CAUTION

Do not stand on lift. Standing on lift can cause personal injury or death. Do not stand on lift. Standing on lift can cause personal injury or death. Do not stand on lift. Standing on lift can cause personal injury or death.

WARNING

WIRE ROPE INSPECTION AND MAINTENANCE

Lifting cables are vital to safe operation. Inspect cables before each use. Do not use cables with frayed, broken, or damaged sections. Do not use cables with a broken or damaged section. Do not use cables with a broken or damaged section. Do not use cables with a broken or damaged section.

ATTENTION

INSPECTION ET ENTRETIEN DES CABLES MÉTALLIQUES

Les câbles de levage sont vitaux pour une opération sûre. Inspectez les câbles avant chaque utilisation. Ne pas utiliser de câbles avec des sections usées, cassées ou endommagées. Ne pas utiliser de câbles avec des sections usées, cassées ou endommagées. Ne pas utiliser de câbles avec des sections usées, cassées ou endommagées.

LIFT OPERATION

TO RAISE LIFT:

- 1. Press and hold UP button for two to three seconds, moving lift off safety locks.
- 2. Hold down Safety Lock Release Handle and Lowering Handle.
- 3. When lift is fully lowered, release both handles.

TO LOWER LIFT:

- 1. Press and hold UP button for two to three seconds, moving lift off safety locks.
- 2. Hold down Safety Lock Release Handle and Lowering Handle.
- 3. When lift is fully lowered, release both handles.

REQUIRE MONTHLY MAINTENANCE

- 1. Check safety locks on lift.
- 2. Check safety locks on lift.
- 3. Check safety locks on lift.
- 4. Check safety locks on lift.
- 5. Check safety locks on lift.
- 6. Check safety locks on lift.
- 7. Check safety locks on lift.
- 8. Check safety locks on lift.
- 9. Check safety locks on lift.
- 10. Check safety locks on lift.

WARNING!

1. NEVER use lift with missing or damaged rubber contact pads.
2. NEVER use lift with missing or damaged rubber contact pads.
3. NEVER use lift with missing or damaged rubber contact pads.
4. NEVER use lift with missing or damaged rubber contact pads.
5. NEVER use lift with missing or damaged rubber contact pads.
6. NEVER use lift with missing or damaged rubber contact pads.

ATTENTION!

1. NEVER use lift with missing or damaged rubber contact pads.
2. NEVER use lift with missing or damaged rubber contact pads.
3. NEVER use lift with missing or damaged rubber contact pads.
4. NEVER use lift with missing or damaged rubber contact pads.
5. NEVER use lift with missing or damaged rubber contact pads.
6. NEVER use lift with missing or damaged rubber contact pads.

I

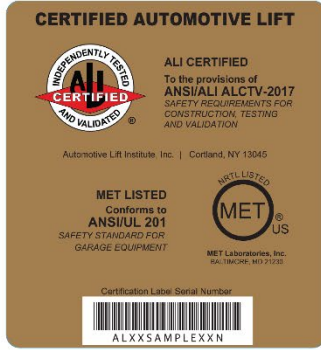

J

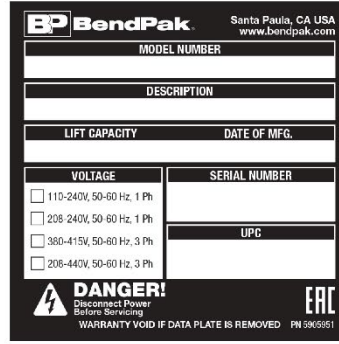

K



L



M



N



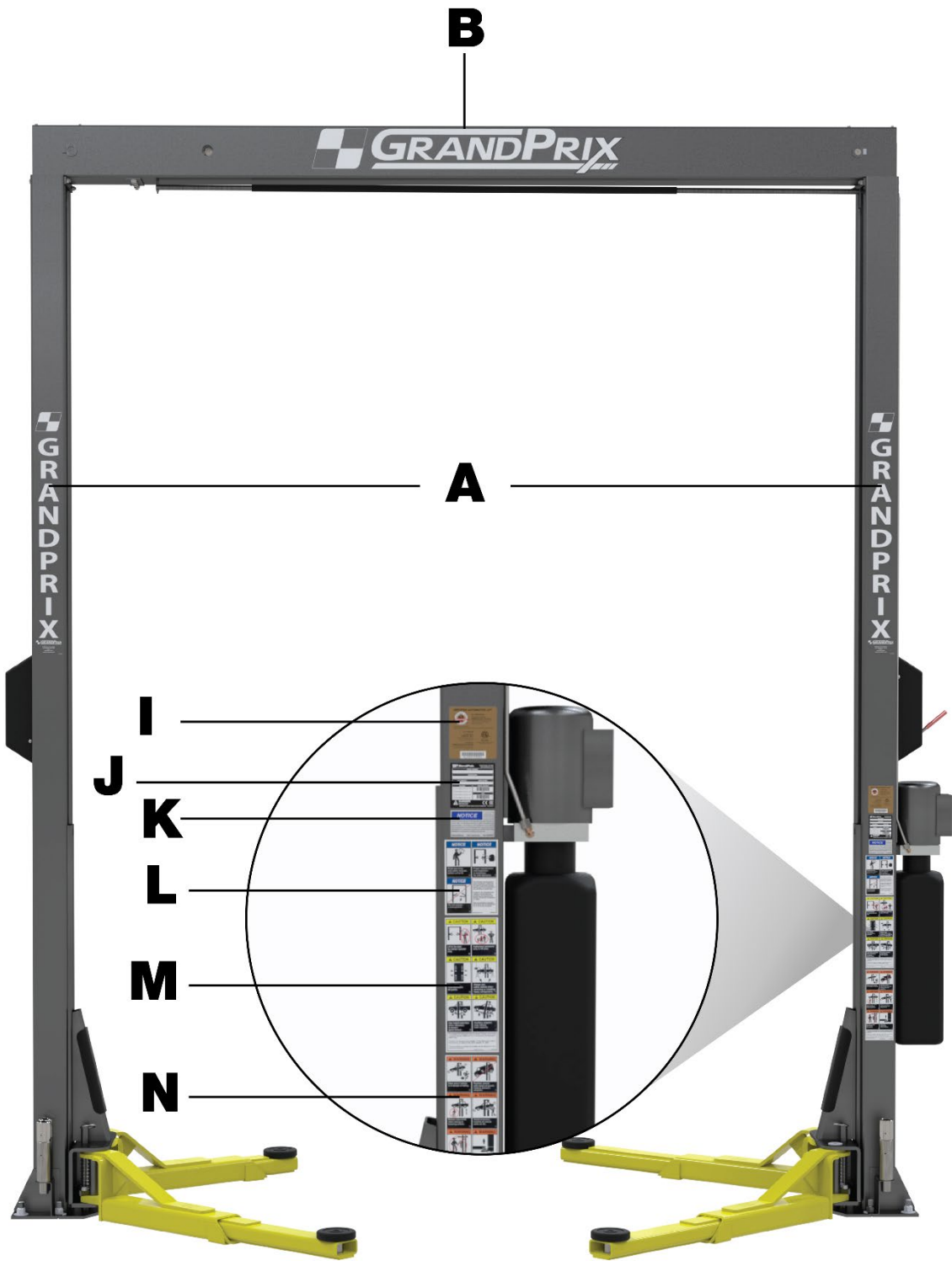

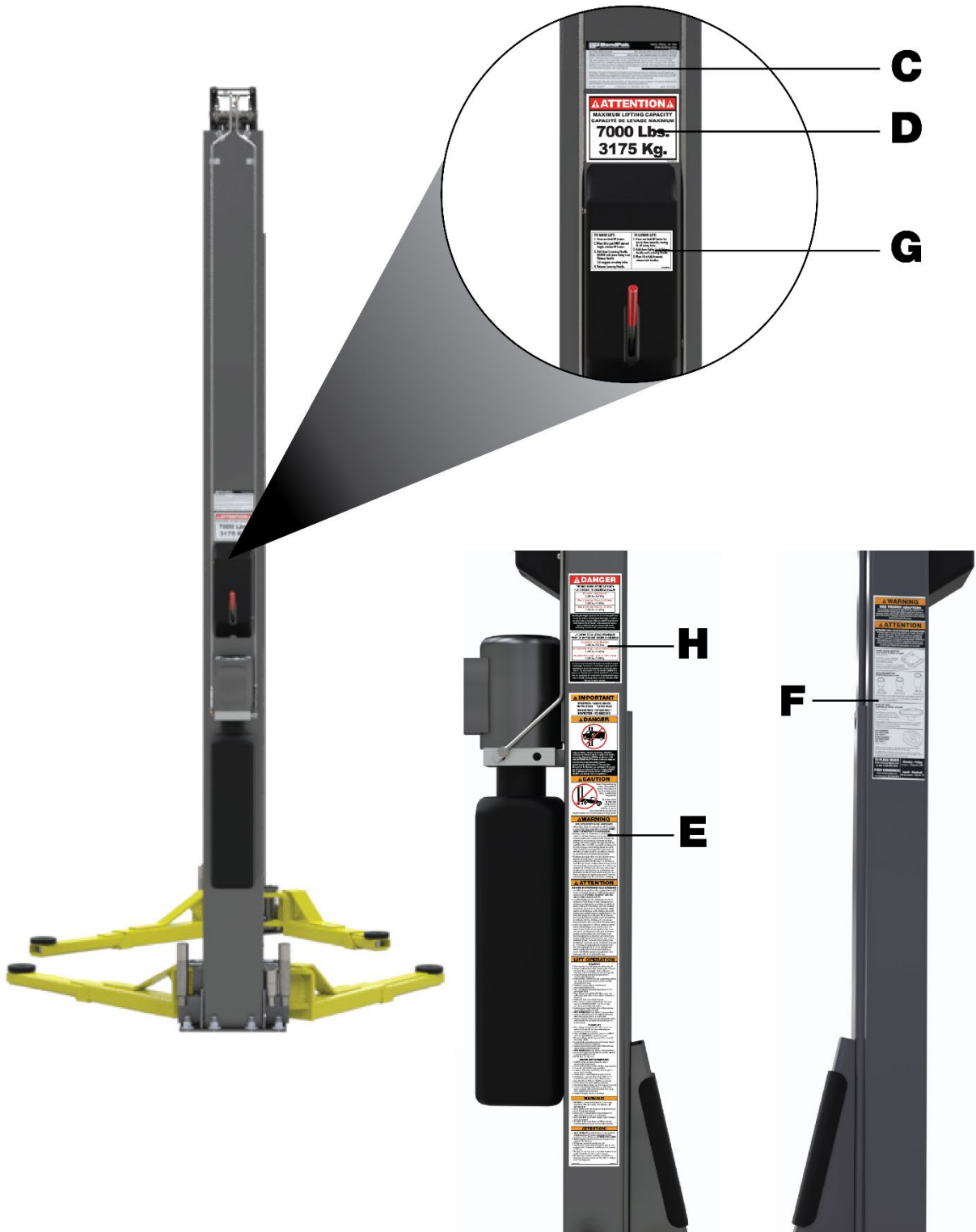



1645 Lemonwood Drive
Santa Paula, CA 93060 USA
bendpak.com

© 2022 by BendPak Inc. All rights reserved.