

Clear Floor Two-Post Lifts

Installation and Operation Manual

Manual P/N 5900374 — Revision A3 — May 2026

Models:

- 12APX
- 12APX-192

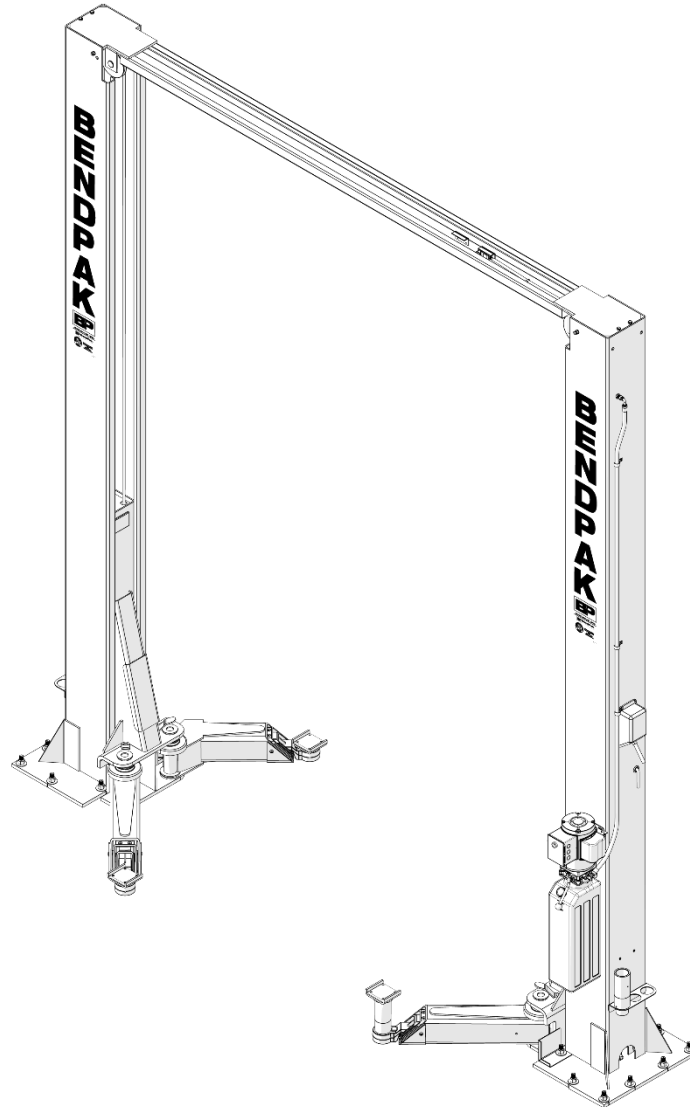

*Original instructions in
the English language.*

12APX Shown

DANGER

IMPORTANT Safety Instructions, save these instructions! Read the *entire contents* of this manual *before* using this product. Failure to follow the instructions and safety precautions in this manual can result in severe injury or death. Make sure all other operators also read this manual. Keep the manual near the product for future reference. *By proceeding with setup and operation, you agree that you fully understand the contents of this manual and assume full responsibility for product use.*

Manual. 12APX Series Two-Post Lifts, *Installation and Operation Manual*, part number 5900374, revision A3, released May 2026.

Copyright. Copyright ©2026 by BendPak Inc. All rights reserved. You may make copies of this document if you agree that: full attribution goes to BendPak Inc., you are not authorized to make changes to the content, you do not gain any rights to this content, and you will not use the copies for commercial purposes.

Trademarks. BendPak and the BendPak logo are registered trademarks of BendPak Inc. All other company, product, and service names are used for identification only. All trademarks and registered trademarks mentioned in this manual are the property of their respective owners.

Limitations. Every effort has been made to ensure complete and accurate instructions are included in this manual. However, product updates, revisions, and/or changes may have occurred since this manual was published. BendPak reserves the right to change any information in this manual without incurring any obligation for equipment previously or subsequently sold. All drawings are reference only – do not scale. BendPak is not responsible for typographical errors in this manual. You can always find the latest version of the **manual for your product on the BendPak website.**



SCAN FOR
DIGITAL PDF

Warranty. The BendPak warranty is more than a commitment to you: it is also a commitment to the value of your new product. Contact your nearest BendPak dealer or visit www.bendpak.com/support/warranty for full warranty details. Go to bendpak.com/support/register-your-product/ and fill out the online form to register your product (be sure to click **Submit**).

Safety. Your Lift was designed and manufactured with safety in mind. Your safety also depends on proper training and thoughtful operation. Do not set up, operate, maintain, or repair the Lift without reading and understanding this manual and the labels on the unit; ***do not use your Lift unless you can do so safely!***

Owner Responsibility. In order to maintain your product properly and to ensure operator safety, it is the responsibility of the product owner to read and follow these instructions:

- Follow all installation, operation, and maintenance instructions.
- Make sure product installation conforms to all applicable local, state, and federal codes, rules, and regulations, such as state and federal OSHA regulations and electrical codes.
- Read and follow all safety instructions. Keep them readily available for operators.
- Make sure all operators are properly trained, know how to safely operate the unit, and are properly supervised.
- Do not operate the product until you are certain all parts are in place and operating correctly.
- Carefully inspect the product on a regular basis and perform all maintenance as required.
- Service and maintain the unit only with approved replacement parts.
- Keep the manual with the product and make sure all labels are clean and visible.
- **BendPak** makes no promises, guarantees or assurances that our products meet any state, county, federal or international mandated permit, license, code, standard, certification, or any other mandate other than what is listed or shown on BendPak website(s), or any BendPak or Ranger online or published catalog. Not all BendPak Lift models meet the standards as prescribed by ANSI/ALI ALCTV-(current edition) or ANSI/UL 201. Consult www.autolift.org for a complete list of Lift models that meet ANSI/ALI ALCTV-(current edition) or ANSI/UL 201, or contact BendPak via contact@bendpak.com. **Buyer assumes full responsibility for any state, county, federal or international mandated permit, license, code, standard, certification, or any other mandate required related to the installation and/or operation of any BendPak product.** BendPak will not be responsible for any charges, fines, liens, or other levies imposed on the Buyer related to any special or regional structural, seismic or any other building code and/or codes such as the Uniform Building Code (UBC), International Building Code (IBC), or any other state, county, federal or international mandated permit, license, code, standard, certification, or other mandate, law, rule, regulation or directive by any other agency, government, administrations, or corporations whether state, county, federal, or international mandated.

Only use the Lift if it can be used safely!

Unit Information. Enter the Model Number, Serial Number, and the Date of Manufacture from the ID label on your unit. This information is required for part or warranty issues.

Model: _____

Serial: _____

Date of Manufacture: _____

Designed and engineered by BendPak Inc. in Southern California, USA. Made in China.

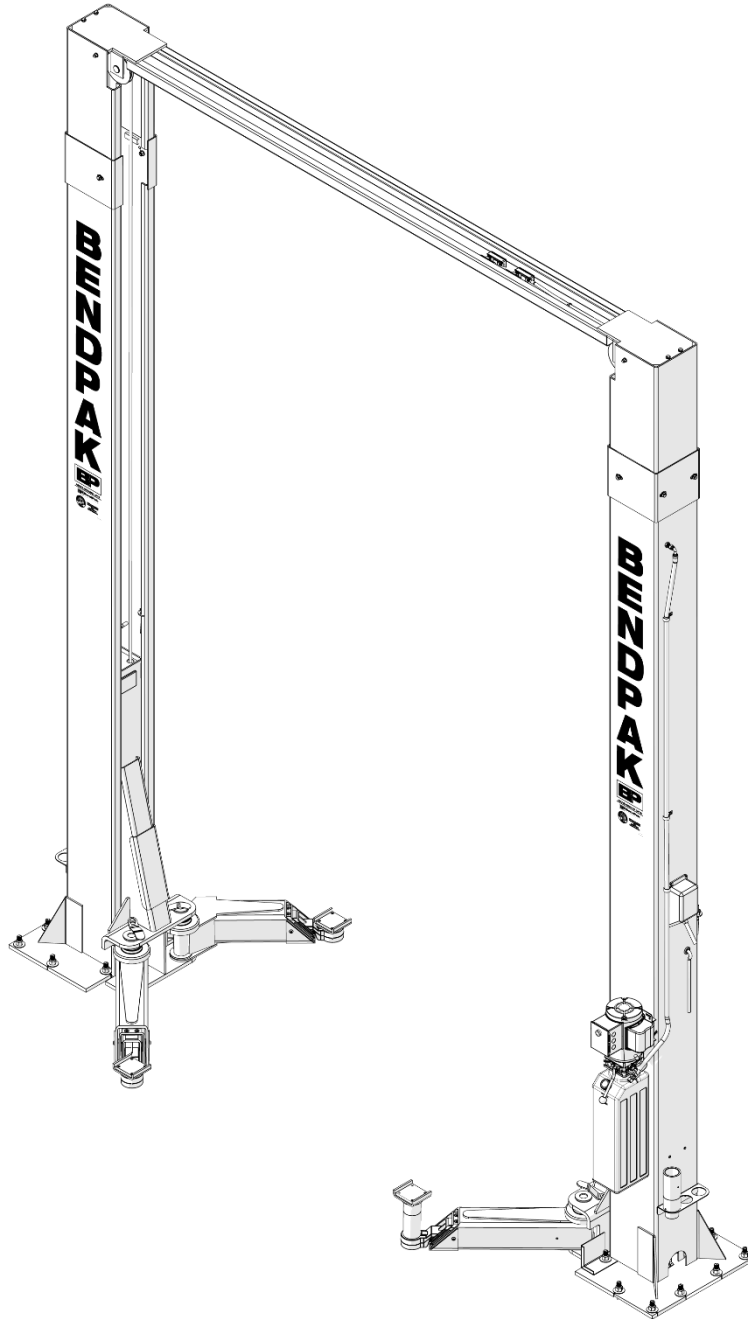

12APX-192 Shown

Table of Contents

| | | | |
|-------------------------------------|-----------|------------------------------|------------|
| Introduction | 4 | Maintenance | 74 |
| Shipping Information | 5 | Troubleshooting | 83 |
| Safety Considerations | 5 | Wiring Diagrams | 87 |
| Components | 8 | Labels | 92 |
| Specifications | 9 | Parts Drawings | 96 |
| Installation Checklist | 11 | ALI Store | 111 |
| Installation | 12 | Maintenance Log | 112 |
| Operation | 63 | | |

Introduction

This manual describes the four BendPak Two-Post Lift models:

- **12APX** A Two-Post Lift with an overall height of 169 in. (4,294 mm) that raises vehicles up to 12,000 pounds (4,536 kg).
- **12APX-192** A taller version of the 12APX with an overall height of 193 in. (4,904 mm), designed to accommodate taller vehicles while raising up to 12,000 pounds (4,536 kg).

Both models have Overhead Assemblies and clear floors.

⚠ DANGER Be very careful when installing, operating, maintaining, or repairing this equipment; failure to do so could result in property damage, product damage, injury, or (in very rare cases) death. Make sure only authorized personnel operate this equipment. An authorized technician must perform all repairs. Do not make modifications to the unit; this voids the warranty and increases the chances of injury or property damage. Make sure to read and follow the instructions on the labels on the unit.

This manual is mandatory reading for all users of 12APX Series Two-Post Lifts, including anyone who installs, operates, maintains, or repairs them. Always keep this manual on or near the equipment.

Technical support and service is available from your dealer, on the Web at bendpak.com/support, by email at support@bendpak.com, or by phone at **(800) 253-2363**, follow the prompts to reach support.

Online chat is also available at www.bendpak.com click the chat icon.



Scan this QR Code for up-to-date information and videos on the 12APX Lift series.



Shipping Information

Your equipment was carefully checked before shipping. Nevertheless, you should thoroughly inspect the shipment **before** you sign to acknowledge that you received it.

When you sign the bill of lading, it tells the carrier that the items on the invoice were received in good condition. **Do not sign the bill of lading until after you have inspected the shipment.** If any of the items listed on the bill of lading are missing or damaged, do not accept the shipment until the carrier makes a notation on the bill of lading that lists the missing or damaged goods.

If you discover missing or damaged goods **after** you receive the shipment and have signed the bill of lading, notify the carrier at once and request the carrier to make an inspection. If the carrier will not make an inspection, prepare a signed statement to the effect that you have notified the carrier (on a specific date), and that the carrier has failed to comply with your request.

It is difficult to collect for loss or damage after you have given the carrier a signed bill of lading. If this happens to you, file a claim with the carrier promptly. Support your claim with copies of the bill of lading, freight bill, invoice, and photographs, if available. Our willingness to assist in helping you process your claim does not make us responsible for collection of claims or replacement of lost or damaged materials.

Safety Considerations

Read this entire manual carefully before using your new product. Do not install or operate the product until you are familiar with all operating instructions and warnings. Do not allow anyone else to operate the product until they are familiar with all operating instructions and warnings.

 **WARNING California Proposition 65.** This product can expose you to chemicals including styrene and vinyl chloride which are on the list of over 900 chemicals identified by the State of California to cause cancer, birth defects, or reproductive harm. Always use this product in accordance with BendPak's instructions. For more information, visit www.p65warnings.ca.gov.

 **WARNING** BendPak does not supply hydraulic fluid or lubricants with this Lift. **Always** refer to the Safety Data Sheet (SDS) for safe handling and disposal information. SDS are available from the hydraulic fluid or lubricant's supplier or manufacturer.

Important Safety Information





Save these instructions! When using this equipment, basic safety precautions should always be followed, including:

1. Read all instructions. Use only as described in this manual.
2. Only operate your Lift between temperatures of 41°F to 104°F (5°C to 40°C).
3. Make sure all operators read and understand this *Installation and Operation Manual*. **Keep the manual near the Lift at all times.** The Lift should only be operated by authorized personnel. Keep children and untrained personnel away from the Lift.
4. BendPak recommends referring to the ANSI/ALI ALIS Standard *Safety Requirements for Installation and Service* for more information about safely installing, using, and servicing your Lift.
5. The Lift should only be operated by authorized personnel. Keep children and untrained personnel away from the Lift.

-
6. Do not make any modifications to the Lift; this voids the warranty and increases the chances of injury or property damage. Use only factory-approved attachments.
 7. Do not use the Lift while tired or under the influence of drugs, alcohol, or medication.
 8. Do not touch hot parts; you could be burned. Always use care with the equipment.
 9. Do not operate equipment with a damaged cord or if the equipment has been dropped or damaged – until a qualified service person has examined it.
 10. Do not let a cord hang over the edge of a table, bench, or counter or come in contact with hot manifolds or moving fan blades. Loop the power cord around equipment when storing.
 11. If an extension cord is necessary, a cord with a current rating equal to or greater than that of the equipment should be used. Cords rated for less current than the equipment may overheat. Care should be taken to arrange the cord so that it will not be tripped over or pulled out.
 12. Always unplug equipment from electrical outlets when not in use. Never use the cord to pull the plug from the outlet. Grasp plug and pull to disconnect.
 13. To reduce the risk of a fire, do not operate equipment in the vicinity of open containers of flammable liquids (such as fuel, thinners, etc.).
 14. Adequate ventilation should be provided when working on operating internal combustion engines.
 15. Keep hair, loose clothing, fingers, and all parts of the body away from moving parts.
 16. To reduce the risk of electric shock, do not use the unit on wet surfaces or expose to rain.
 17. Always wear safety glasses! Everyday glasses only have impact resistant lenses, they are not safety glasses.
 18. **12APX Series Lifts** are Two-Post Service Lifts. *Use them only for their intended purpose.*
 19. You must wear OSHA-approved (publication 3151) personal protective equipment **at all times** when installing, using, maintaining, or repairing the Lift. Leather gloves, steel-toed work boots, eye protection, back belts, and hearing protection are **mandatory**.
 20. **Never** exceed the rated capacity of the Lift.
 21. When the Lift is in use, keep hands and all body parts well away from it.
 22. Keep loads balanced on the Lift Arm Assemblies. Clear the area immediately if a vehicle is in danger of falling off the Lift.
 23. Modifications void the warranty and increases the chances of injury or property damage. *Do not modify any safety-related features in any way.*
 24. The Lift uses electrical energy; if your organization has Lockout/Tagout policies, make sure to implement them after connecting the Lift to a power source.
 25. When handling the hydraulic components, **always wear safety gloves!** In rare cases, a needle-like stream of hydraulic fluid (even at low pressure) can penetrate fingers, hands, or arms. Such a puncture can feel like a bite, electric shock, or a prick. While it may seem like a minor issue, any amount of hydraulic fluid injected into the human body is a serious issue. Anyone suffering such a puncture wound should be **immediately** taken as an emergency to the hospital to determine the extent of the injury. Explain the circumstances of the injury to the attending physician, including what type of hydraulic fluid was involved. Do not assume a puncture wound that could have been caused by hydraulic fluid is a minor issue; it could be life-threatening.
 26. Make a visual inspection of the Lift before using it. Do not use the Lift if you find any missing or damaged parts. Instead, take it out of service, then contact an authorized repair facility, your distributor, or BendPak at **(800) 253-2363** follow the prompts to reach sales or email sales@bendpak.com.
 27. BendPak recommends making a **thorough** inspection of the Lift at least once a year. Replace any damaged or severely worn parts, decals, or warning labels.

Symbols

Following are the symbols used in this manual:

-  **DANGER** Calls attention to an immediate hazard that **will** result in death or severe injury.
-  **DANGER** Calls attention to an electrical hazard that **will** result in death or injury.
-  **WARNING** Calls attention to a hazard or unsafe practice that **could** result in death or severe personal injury.
-  **CAUTION** Calls attention to a hazard or unsafe practice that could result in minor personal injury, product damage, or property damage.
- NOTICE** Calls attention to a situation that could result in product or property damage.
-  **Tip** Calls attention to information that can help you use your product better.

Liability Information

BendPak assumes **no** liability for damages resulting from:

- Use of the equipment for purposes other than those described in this manual.
- Modifications to the equipment without prior, written permission from BendPak.
- Injury or death caused by modifying, disabling, overriding, or removing safety features.
- Damage to the equipment from external influences.
- Incorrect operation of the equipment.

Components

Not all components shown. Models with extensions are taller. Reference only – do not scale.

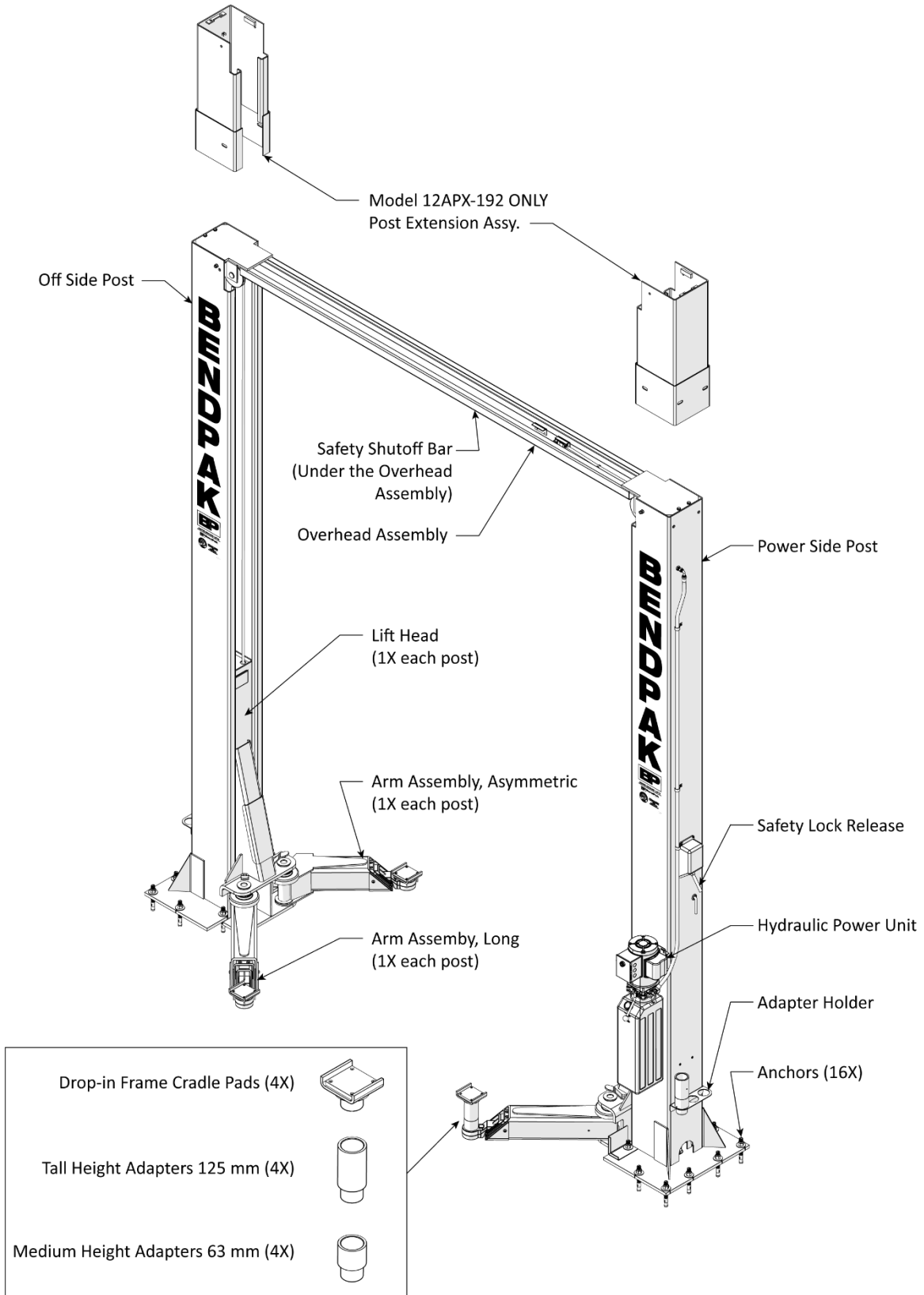

Specifications

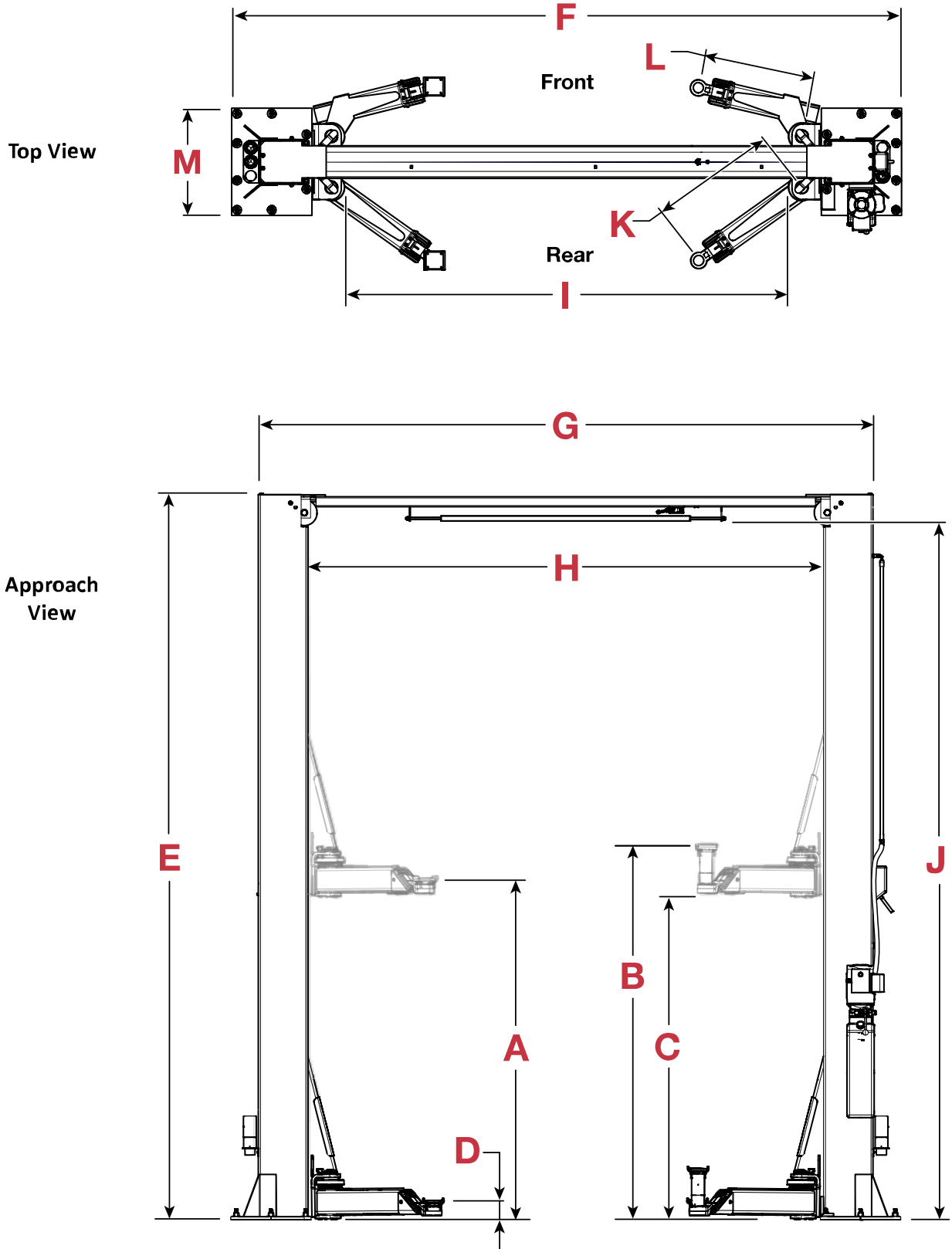

Reference only – do not scale.

Specifications subject to change without notice.

Unless otherwise noted, all dimensions are rounded to the nearest 0.25 in. (6.3 mm)

| Model | 12APX | 12APX-192 |
|---|---|----------------------|
| Lifting Capacity | 12,000 lbs. (5,443 kg) | |
| Max. Capacity — Front Axle | 6,000 lbs. (2,722 kg) | |
| Max. Capacity — Rear Axle | 6,000 lbs. (2,722 kg) | |
| Max. load per Lift Arm | 3,000 lbs. (2,268 kg) | |
| A – Max. Lifting Height w/ Pad (Top Lock) ¹ | 79.25 in. (2,015 mm) | |
| B – Max. Lifting Height w/Adapters ² | 87.75 in. (2,229 mm) | |
| C – Max. Rise (No lock engaged) | 76 in (1,932 mm) | |
| D – Min. Height w/ Pad | 4.25 in. (108 mm) | |
| E – Overall Height | 169 in. (4,294 mm) | 193 in. (4,904 mm) |
| F – Width Overall | 156 in. (3,959 mm) | |
| G – Outside Posts | 143 in. (3,633 mm) | |
| H – Inside Posts | 120 in. (3,047 mm) | |
| I – Drive-Thru Width | 103 in. (2,619 mm) | |
| J – Floor to Top Switch | 163.5 in. (4,154 mm) | 187.5 in. (4,764 mm) |
| K – Rear Arm Reach (min. – max.) ³ | 29.25 in. (745 mm) min. to 60 in. (1,524 mm) max. | |
| L – Front Arm Reach (min. - max) ³ | 26 in. (660 mm) min. to 55.25 in. (1,404 mm) max. | |
| M – Base Plate Width | 25 in. (634 mm) | |
| Operating Pressure at Maximum Load | 2,220 psi | |
| Time to Full Rise | ≈ 68 seconds | |
| Motor Power Consumption Range (typical) ⁴ | 230 VAC, 50/60 Hz, 1 Ph, 5 HP, approx. 19.5 Amps | |
| Hydraulic Fluid Required | 3.6 gallons (13.6 Liters) | |
| Operating Temperature | 41° to 104° F (5° to 40°C) | |
| Sound Pressure | 81dB peak level | |

¹ *Lifting Height w/Pad* is the maximum lifting height at top lock with Pad only and no adapter(s).

² *Maximum Lifting Height w/adapters* is the maximum lifting height with both tall and medium adapters installed.

³ Lift arms are measured from the Lift Arm's axis of rotation to the frame cradle pad mounting pin center.

⁴ Special voltages available upon request.

Installation Checklist

Following are the steps required to install a 12APX Series Two-Post Lift; perform them in this order.

- 1. Review the safety rules.
- 2. Make sure you have the necessary tools.
- 3. Plan for electrical work.
- 4. Select the installation location.
- 5. Review the installation orientation and required clearances around the Lift.
- 6. Install the post extensions 2APX-192 ONLY
- 7. Route and position the safety cable
- 8. Route and position the equalizing cables
- 9. Route and position the hydraulic hoses
- 10. Create chalk line guides for the posts.
- 11. Raise and anchor the posts.
- 12. Prepare and install the overhead assembly and limit switch.
- 13. Route and install the safety lock cable.
- 14. Complete the equalizing cables' installation.
- 15. Install the double threaded rod.
- 16. Learn about hydraulic fluid contamination.
- 17. Learn about liquid thread sealant.
- 18. Read hydraulic system warnings
- 19. Mount the power unit (*do not connect to power*).
- 20. Complete connecting the hydraulic hoses and fittings
- 21. Install the lift arm assemblies.
- 22. Level the Lift
- 23. Contact the Electrician.
- 24. Connect the overhead limit switch (***Electrician Required***)
- 25. Connect the power unit (***Electrician Required***).
- 26. Install the power disconnect (***Electrician required***).
- 27. Install a thermal disconnect, if required by local code (***Electrician required***).
- 28. Lubricate the Lift.
- 29. Review the final checklist.
- 30. Test the Lift
- 31. Leave the Lift manual and any additional information delivered with the Lift with the Owner/Operator.

Installation

The installation process includes multiple steps. Perform them in the order listed.

 **WARNING** Use only the factory-supplied parts shipped with your Lift. If you use attachments, accessories, or configuration modifying components that are in the path and/or affect the operation of the equipment, affect the equipment's electrical listing, or affect the intended vehicle accommodation, and if they are not certified for use with this Lift, then you void the warranty of the Lift as well as compromising the safety of everyone who sets up or uses the Lift. If you are missing parts, visit [BendPak.com/Support](https://www.bendpak.com/Support), email support@bendpak.com or contact BendPak technical support by phone at **(800) 253-2363**, follow the prompts to reach support. Online chat is also available at www.bendpak.com click the chat icon.

Review the Safety Rules

When installing a Lift, your safety depends on proper training and thoughtful operation. BendPak recommends referring to the ANSI/ALI ALIS Standard *Safety Requirements for Installation and Service* for more information about safely installing, using, and servicing your Lift.

 **WARNING** Do not install this equipment unless you have automotive lift installation training. Always use proper lifting tools, such as a Forklift or Shop Crane, to raise heavy components. Do not install this equipment without reading and understanding this Manual and the Labels on the unit.

 **WARNING** Many of the Lift components are heavy and awkward to work with. Installation should be accomplished by competent personnel ensuring all heavy components are properly rigged and balanced for lifting. Installation personnel should have knowledge, training, and experience in lifting, rigging, and securing heavy objects.

 **WARNING** You must always wear appropriate protective equipment during installation: leather gloves, steel-toed work boots, eye protection, back belts, and hearing protection.

Tools and Supplies Required

You may need some or all the following tools:

- Rotary hammer drill (or similar)
- 3/4 in. carbide bit (conforming to ANSI B212.15)
- Hammer
- Four-foot level
- Open-end wrench set, SAE, and metric
- Socket and ratchet set, SAE, and metric
- Hex-key wrench set
- Crescent and pipe wrenches
- Red and White Lithium Grease
- Crowbar
- Chalk line
- Medium-sized flat screwdriver
- Tape measure, 25 feet or more
- Needle-nose pliers
- Forklift or Hoist/Crane
- Two 12-foot ladders
- Two sawhorses
- Torque wrench

Prepare for Electrical Work

You will need to have a licensed Electrician available at some point during the installation.

⚠ DANGER All wiring must be performed by a licensed Electrician in accordance with applicable national, state, and local electrical codes, rules, and regulations, such as state and federal OSHA regulations and electrical codes.

NOTICE! Notify your Electrician in advance so they arrive prepared with the items required to connect to the facility's power system, or an appropriate power cord with plug to connect to a power source, and a Power Disconnect Switch. A thermal disconnect switch may be required by local electrical code. **These items are not supplied with the Lift.**

The Electrician needs to:

- **Connect to the VAC power source.** The power unit comes with a pigtail for wiring to a power source. Have your Electrician connect a power cord with plug to the electrical box on the Lift for connection to a power outlet or have them wire it directly into the electrical system at the Lift location. The Lift's power unit must be protected by an appropriate circuit breaker.
- **Connect the limit switch wiring to the power unit.** The limit switch must be wired to the power unit. The required 2-conductor cable is included with the Lift.
- **Install a power disconnect switch.** A power disconnect switch is used to shut down the Lift in the event of an electrical circuit fault, emergency, or when the Lift is being serviced. Refer to [Installing a Power Disconnect Switch](#) for more information.
- **Install a thermal disconnect switch**, if required by local electrical code. Refer to [Installing a Thermal Disconnect Switch](#) for more information.

Select a Location

When selecting the location for your Lift, consider the following:

- **Architectural plans.** Consult the architectural plans for the desired location. Make sure there are no contradictions between what you want to do and what the plans allow.
- **Available space.** Make sure there is enough space for the Lift: front, back, sides, and **above**. Refer to [Specifications](#) for exact measurements. Check for overhead obstructions such as building supports, heaters, lights, electrical lines, low ceilings, and/or other obstacles.
- **Power.** An appropriate electrical power source for the Lift's power unit is required.
- **Outdoor installations.** 12APX Series Two-Post Lifts are approved for indoor installation and use only. **Outdoor installation is prohibited.**
- **Floor.** Only install the Lift on a flat, concrete floor; do not install on asphalt or any other surface. The surface must be level; do not install if the surface has a slope greater than or equal to 3°.

⚠ DANGER Risk of explosion: This equipment has internal arcing or parts that may spark and should not be exposed to flammable vapors. The power unit's motor should not be located in a recessed area or below floor level.

⚠ DANGER Installing the Lift on a surface with more than three degrees of slope could lead to injury or even death. Only install your Lift on a level floor. Level is defined as no more than 3/8 in. (9.5 mm) difference over the installation area. If your floor is not level, consider making the floor level or using a different location.

⚠ CAUTION Never expose the motor to rain or other damp, wet environments; damage to the motor caused by fluids is not covered by the warranty.

-
- **Concrete specifications.** The concrete must be steel reinforced, a minimum 6 in. (150 mm) thick, 3,000 PSI minimum compressive strength, and cured for a minimum of 28 days. Do not install the Lift on cracked or defective concrete. Anchor bolts must be more than six inches from cracks and expansion joints in the concrete or from a wall.

⚠ CAUTION BendPak Lifts are supplied with installation instructions and concrete anchors that meet the criteria set by the latest version of the American National Standard in Automotive Lifts – Safety Requirements for Construction, Testing, and Validation in., ANSI/ALI ALCTV. Consult with an expert for any special regional structural and/or seismic anchoring requirements specified by any other agencies and/or codes such as the Uniform Building Code (UBC) and/or International Building Code (IBC) (ALI).

Verify that the concrete floor is not a post-tension slab. If the slab is post-tensioned, contact the building architect or the department of building and safety **before** drilling. Using ground penetrating radar may help locate the tensioned steel.

⚠ DANGER Cutting through a tensioned cable can result in injury or death. Do not drill into a post-tension slab unless the building architect confirms you are **not** going to hit tensioned steel, or it has been located using ground penetrating radar. **If a colored sheath comes up during drilling, stop drilling immediately.**

- **Unloading the components.** Unload the Lift components as close to the installation location as possible. The Lift includes several heavy components, so the closer they are unloaded to the installation location, the better.

⚠ WARNING Some Lift components are very heavy; if handled incorrectly, they can damage materials they are placed on like tile, sandstone, and brick. Try to handle the Lift components just twice: once when delivered and once when moved into a suitable position. You must have a forklift or shop crane to move some of the Lift components into position. **Use care when moving Lift components.**

Review the Installation Orientation

Keep these factors in mind when deciding how to orient the Lift:

- The first thing to figure out is which direction you will be driving the vehicles in, called the **Approach**.
 - In most cases there is a driveway on one side and a wall on the other side. The driveway is your Approach. This makes the wall side the Front of the Lift and the driveway side the Rear of the Lift.
 - If both sides are open, decide which way you will be driving vehicles onto the Lift. This is the Approach; the drive-**on** side is the Rear of the Lift and the drive-**off** side if the Front.
- While the power unit **must** be installed on the power side post, that power side post may be mounted on either side of the Lift. You can identify the power side post by the Mounting Bracket to which the power unit attaches. Refer to the figures below.

⚠ CAUTION

When installing the overhead Assembly, always orient the assembly to place the limit switch on the power unit side of the Lift.

**Top View
Approach Side**

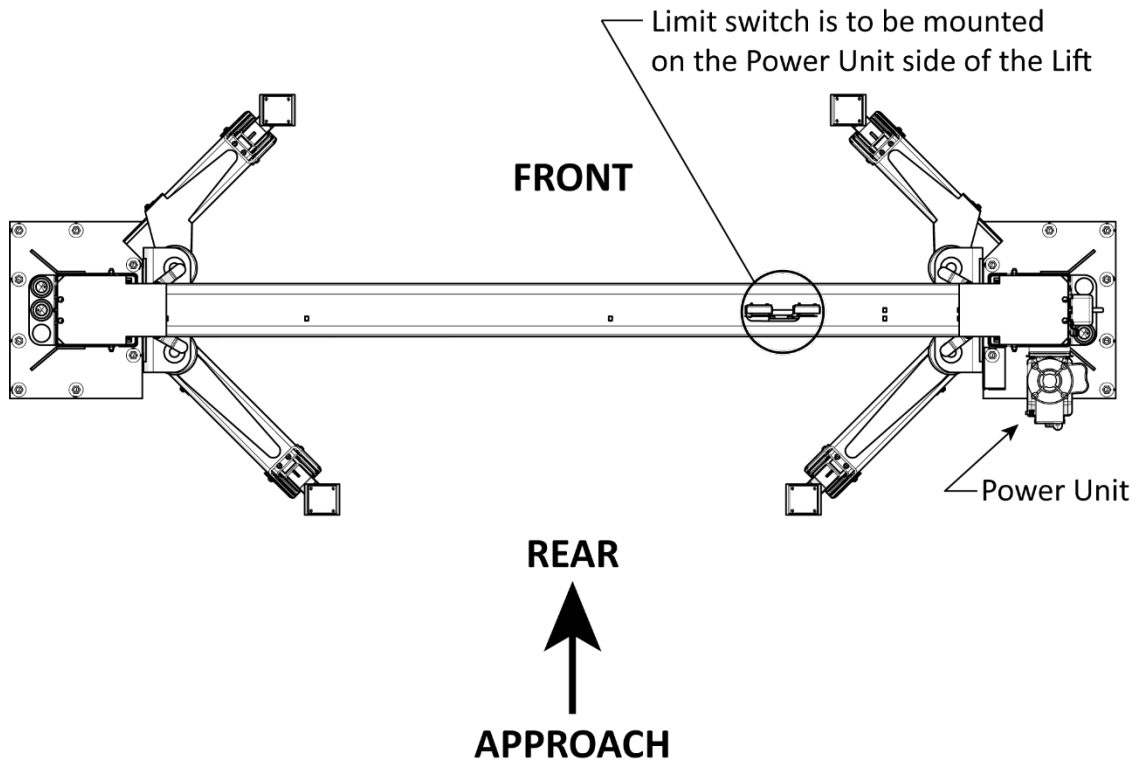

**Top View
Power Unit
Opposite Approach**

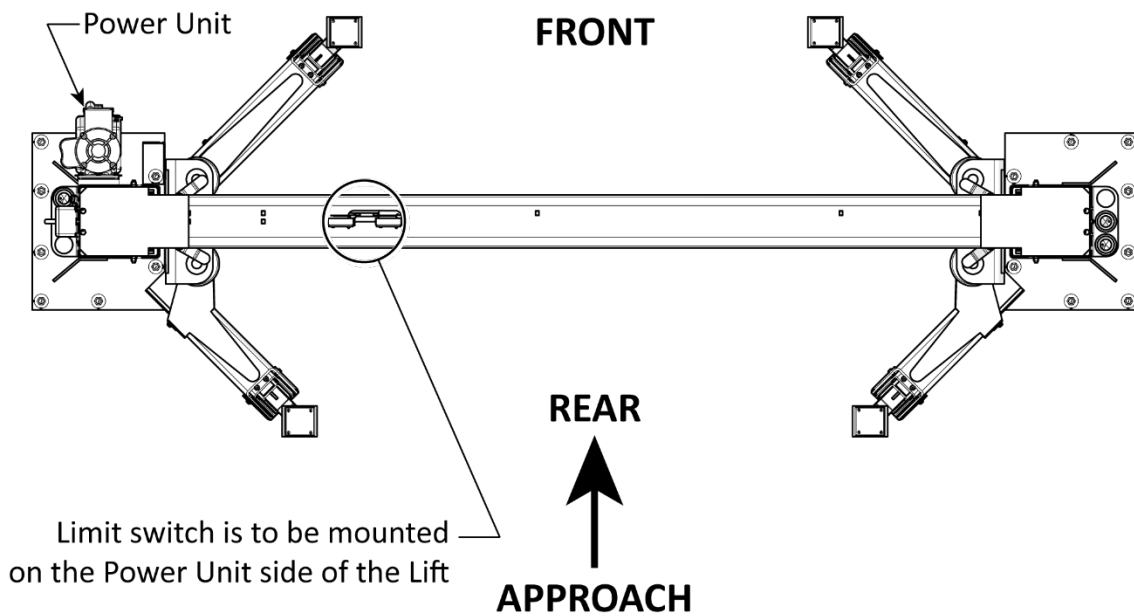

Check the Clearances

Clearance around and above the Lift is **required for safety**. Provide adequate clearance around the lift to ensure safe operation, vehicle positioning, and service access. Surrounding equipment, walls, and structural elements should be arranged to allow free and unobstructed movement of personnel, vehicles, and service equipment such as oil drains, tool carts, and other shop apparatus through adjacent work areas and access lanes. Auxiliary and utility services should be routed so they do not interfere with lift operation or prevent removal of access covers or service panels. For proper anchor performance, position the lift no closer than 6 in. (150 mm) from any foundation expansion joint, control joint, or edge of the concrete slab. Refer to the figure below.

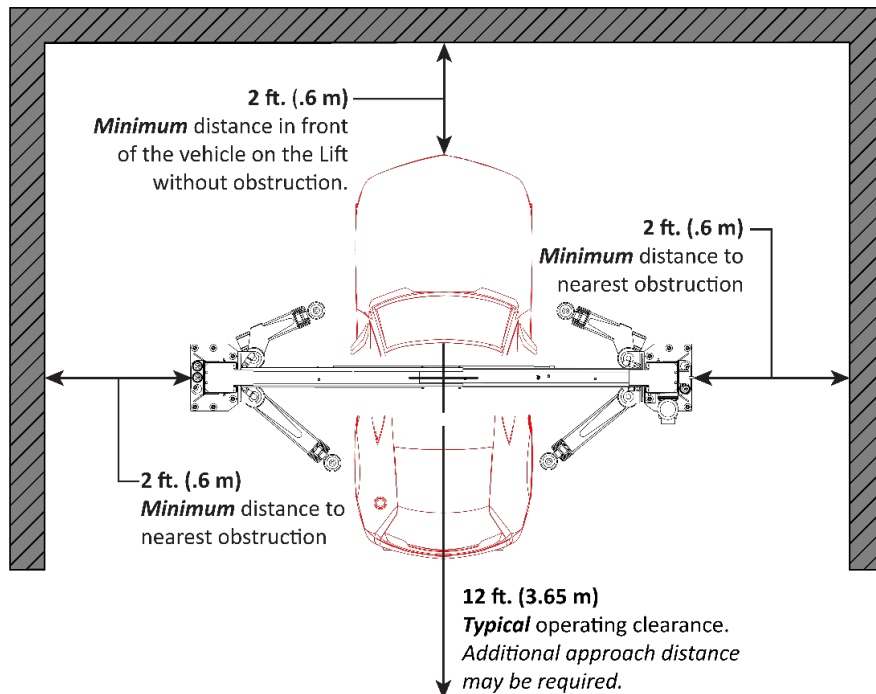

1 in. (25 mm) minimum clearance required above the Lift.

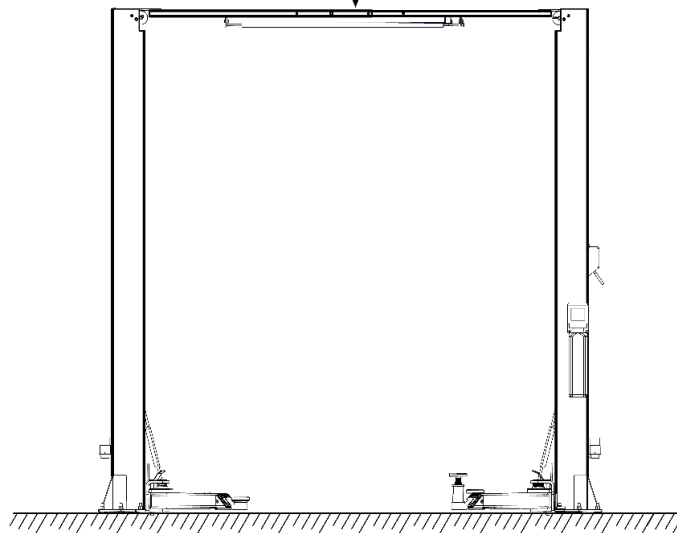

Additional distance WILL be required on the front and/or rear allowing vehicles to be driven in or out.

Move the Lift to the Installation site

Move the Lift posts and materials to the installation site.

⚠ WARNING Many of the Lift components are heavy and awkward to work with. Installation should be accomplished by competent personnel ensuring all heavy components are properly rigged and balanced for lifting. Installation personnel should have knowledge, training, and experience in lifting, rigging, and securing heavy objects.

Install the Post Extensions 12APX-192 only

12APX-192 models are supplied with post extensions that increase the height of the lift posts to allow service on taller vehicles.

The post extensions are slipped over the top of both posts and then bolted into place.

To install the post extensions:

1. Arrange both posts either flat on the ground or elevated on sturdy work supports. The **insides** of the posts must be accessible, facing up.
2. Remove the Lift arms and parts box/bag from the Lift.
3. Locate and retrieve the two post extensions, hex head bolts, flat washers, split-lock washers, and hex nuts. Reference the table and illustration below.
4. Slide one of the post extensions over the top of one of the posts.
5. The open side of the post extension must face the inside of the Lift.
6. Secure the post extension to the lift post on all three sides, using the fasteners listed below.
7. Repeat the process by mounting the remaining post extension to the remaining lift post and secure in the same manner.

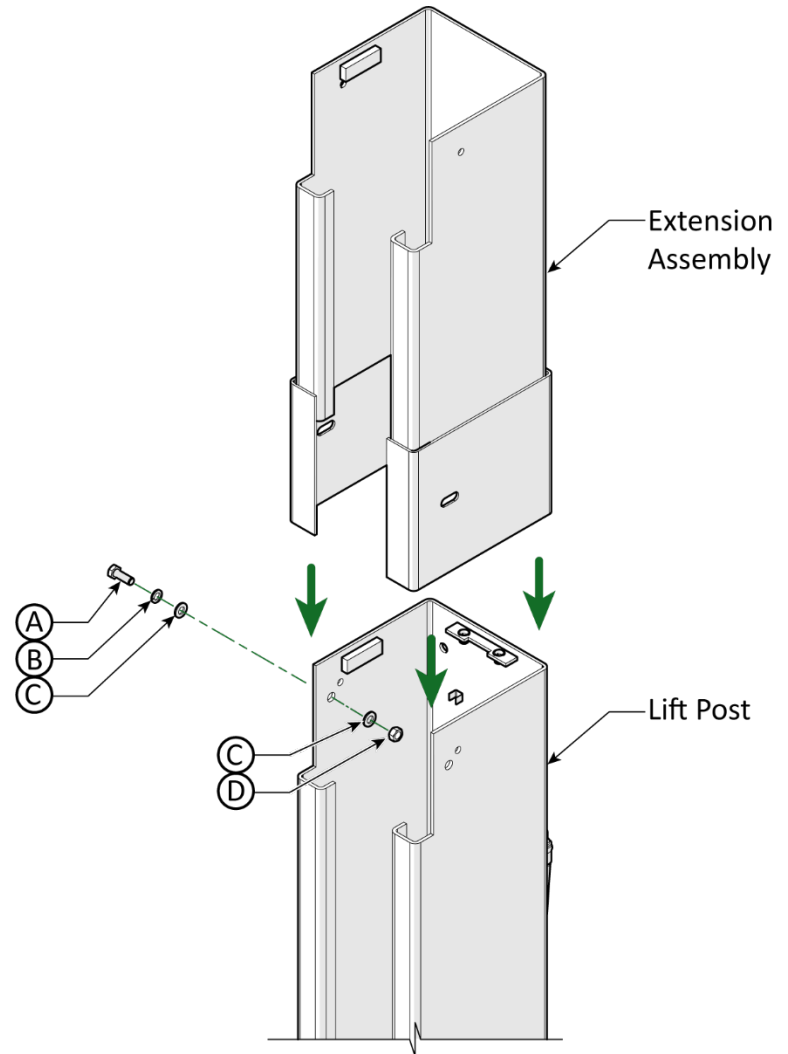

| Item | Part Number | Description | Qty. |
|----------|-------------|-------------------------------|------|
| A | 5530076 | Hex Head Bolt M12 x 1.75 x 35 | 4 |
| B | 5545201 | Washer, Split Lock M12 x 21 | 4 |
| C | 5545347 | Washer, Flat M12 x 24 | 8 |
| D | 5535354 | Hex Nut, M12 | 4 |

Route and Position the Safety Lock Cable

12APX Series Lifts include two safety lock assemblies inside the Lift posts: one on the power side post (above the power unit) and the other on the off side post at the same height.

The two safety assemblies engage the lift head and prevent it from lowering. The safety release mechanism allows the lift head to move past the safety locks and lower to the ground. The safety assemblies must be disengaged **at the same time** so that both lift heads lower together. To accomplish this, the two safety assemblies are connected to each other via a safety lock cable, which is routed through the Lift posts and the overhead assembly.

Power Side Safety: The power side Safety includes a safety lock cable release handle and mechanism used to disengage the safety locks when lowering the Lift.

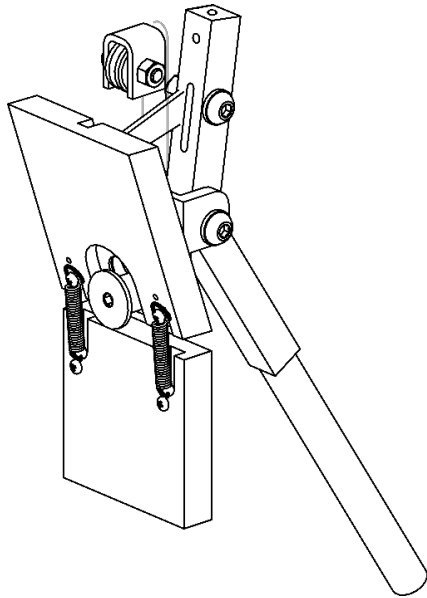

Off Side Safety: Similar to the power side Safety, except that it lacks safety lock cable release handle and mechanism.

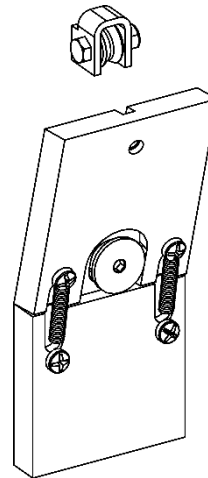

1. Arrange both posts either flat on the ground or elevated on sturdy work supports. The **insides** of the posts must be accessible, facing up.
2. Locate the safety lock cable and remove the wire tie binding the coiled cable.
3. Uncoil the safety cable and route the cable behind the safety cable sheave.
4. Route the cable up to the top of the off side post. **Coil the cable and secure with tape or a wire tie at the top of the off side lift post until called for later in the assembly.** *Part number and cable length varies based on lift model.*

| Model | Part Number | Safety Cable Diameter. and Length |
|-----------|-------------|-----------------------------------|
| 12APX | 5595759 | Ø1.8 x 8,850 mm |
| 12APX-192 | 5595761 | Ø1.8 x 10,070 mm |

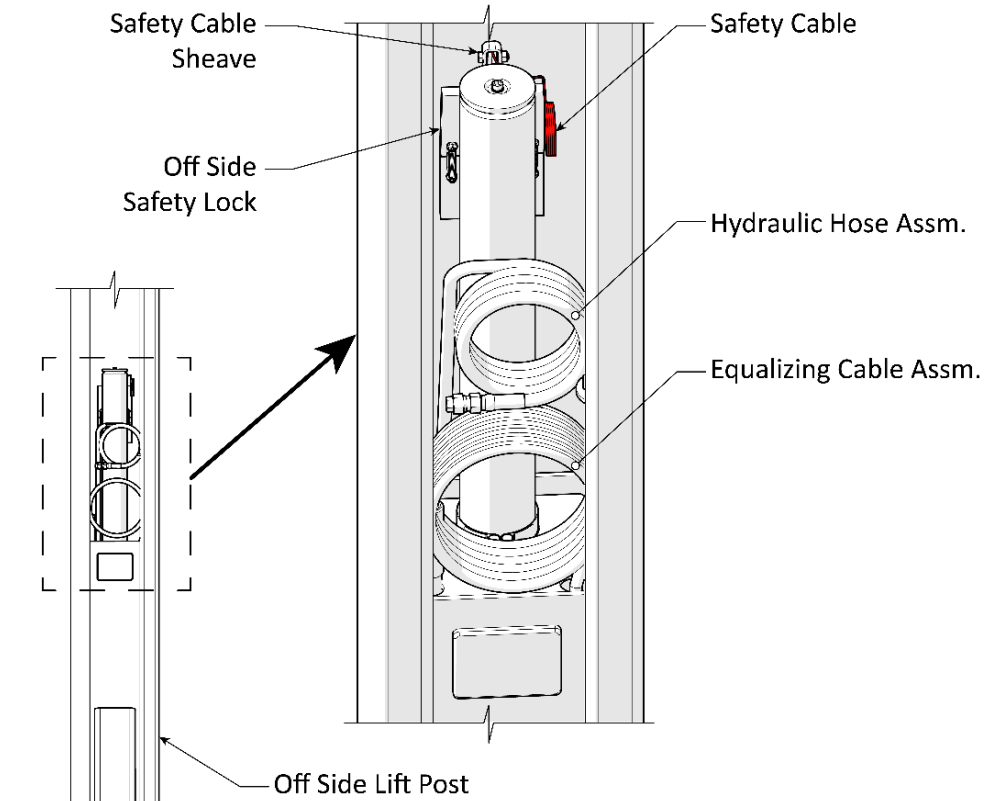

Reference only – do not scale.

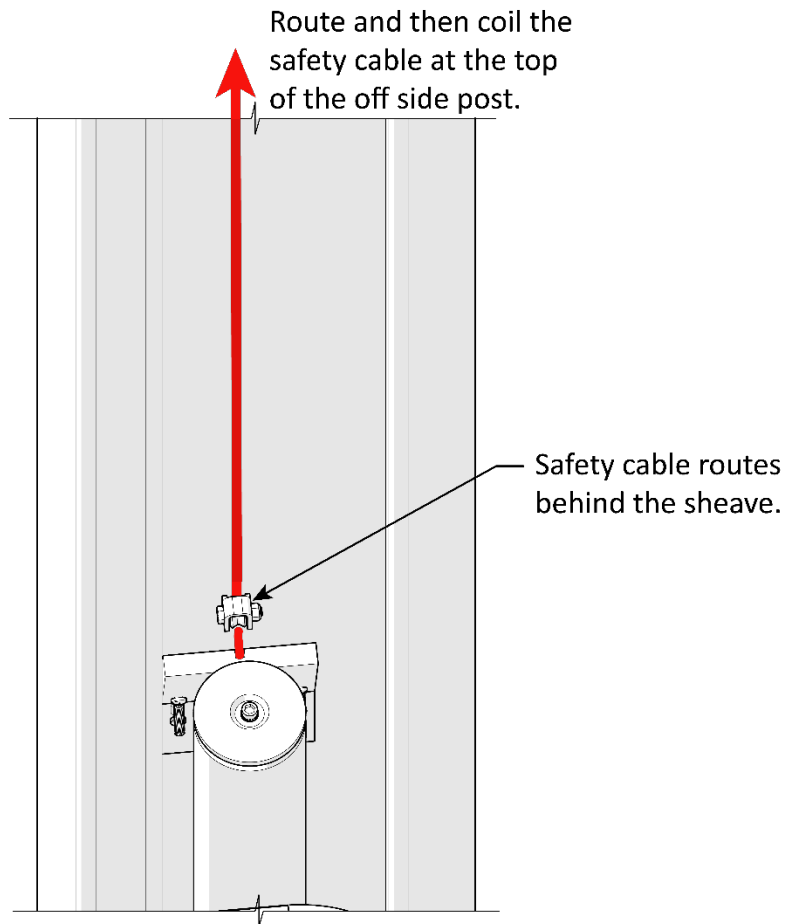

5. Move to the power side post.
6. Retrieve the safety pivot holder and the safety handle from the parts box.
7. Connect the pivot pin and safety pivot holder using the M8 x 25 machine screw already installed in the power post. Take care not to lose the safety pivot holder inside the power post. Refer to the figure below.

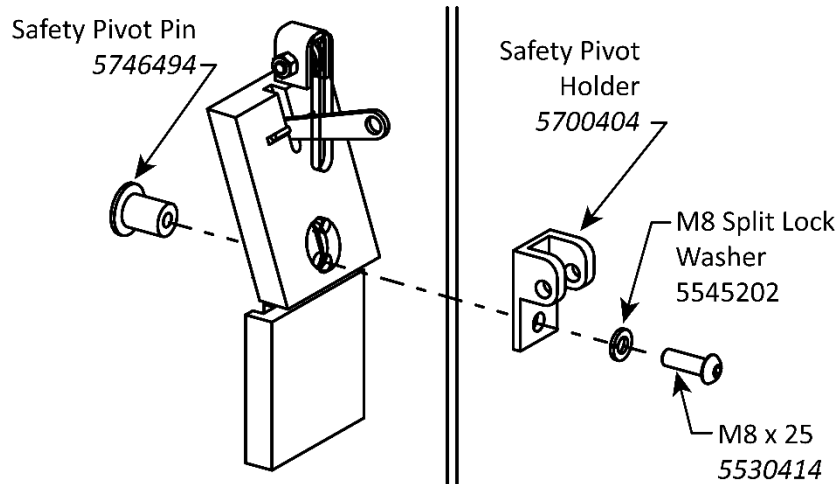

8. Retrieve one BHSK M8 x 30 and M8 x 40 screws and two M8 lock washers and nylock hex nuts.
9. Attach the safety release handle (5761017) as depicted below.

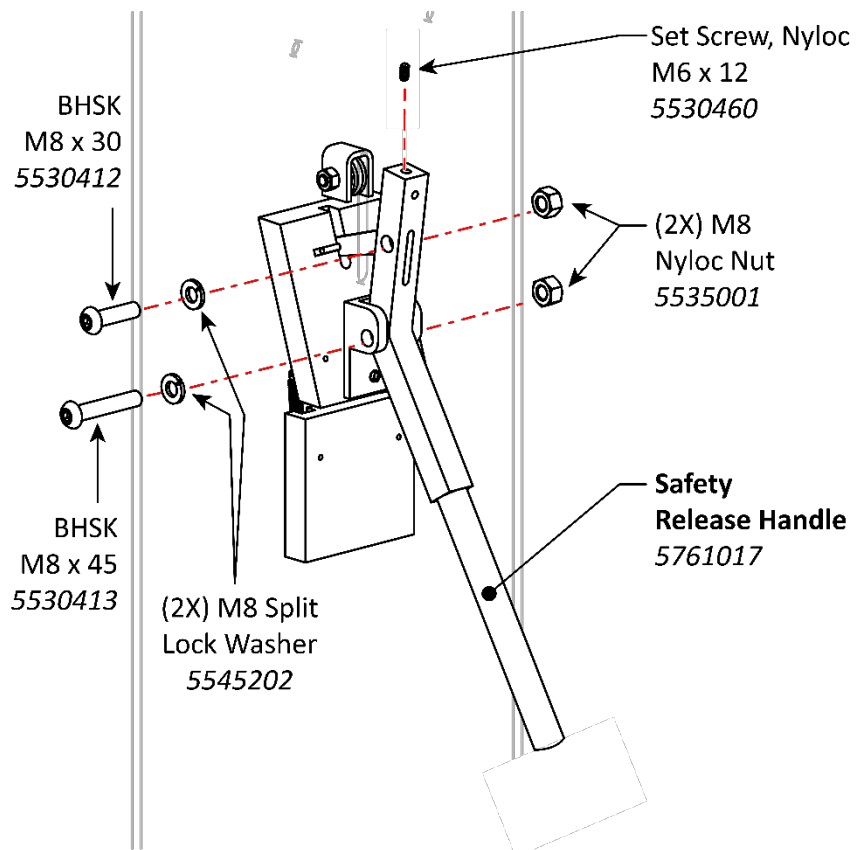

Reference only – do not scale.

Route and Position the Equalizing Cables

Move the equalizing cables into position **before** standing up the lift posts.

NOTICE The two equalizing cables are the same length.

The following graphic provides an overview of the equalizer cable routed into position.

Not to scale, components removed for clarity.

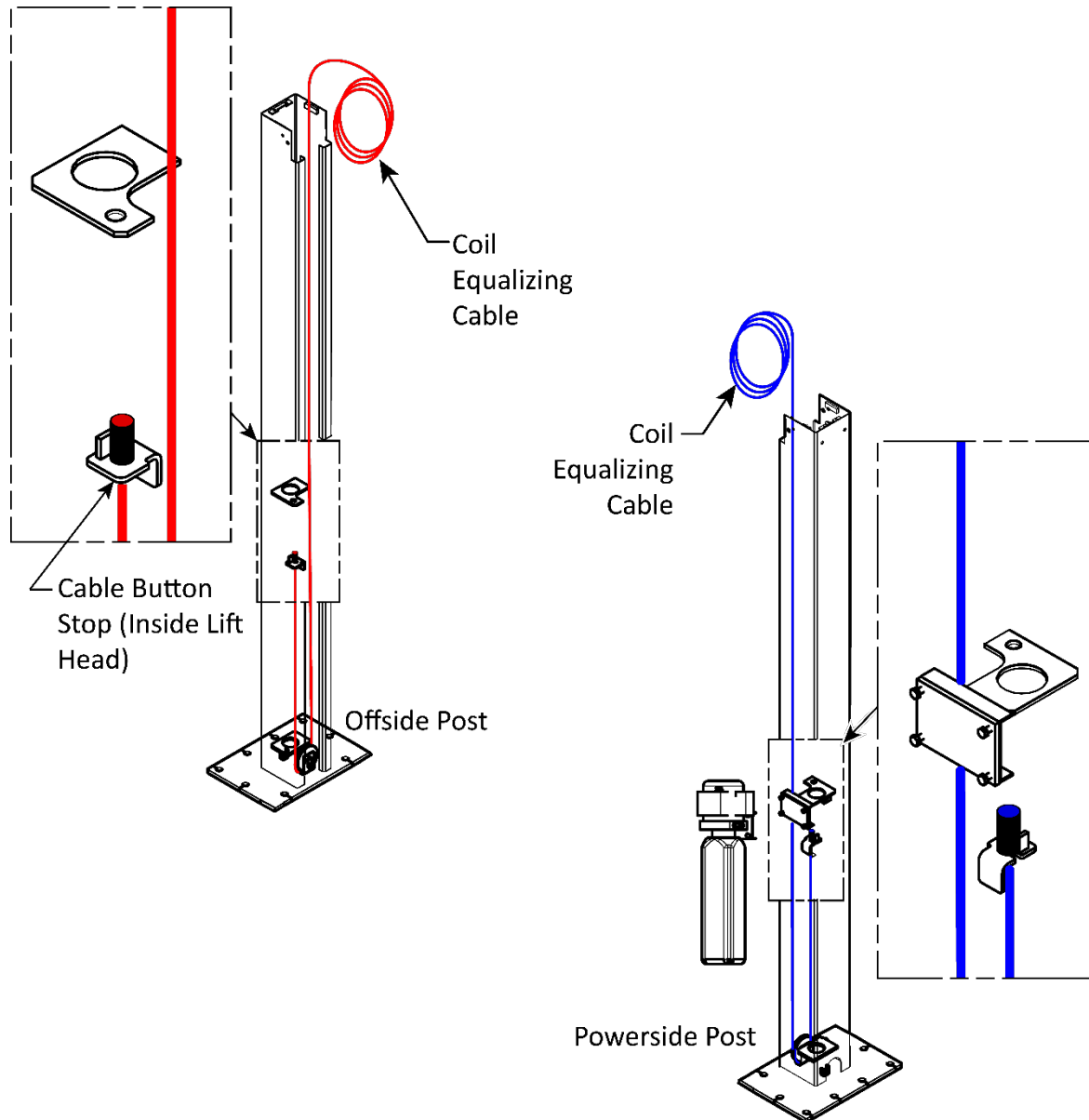

Position the Equalizing Cables

⚠ CAUTION BendPak recommends wearing safety gloves when handling the equalizing cables.

1. Arrange both posts either flat on the ground or elevated on sturdy work supports. The **insides** of the posts must be accessible, facing up.
2. Choose a lift post and locate the equalizing cable. *Each post has one equalizing cable with the button end preinstalled into the lift head's cable button stop. The remainder of the cable is coiled and secured in the post.*

Each model has a specific equalizing cable length as noted in the table below.

| Model | Part Number | Equalizing Cable Assembly Diameter and Length |
|-----------|-------------|---|
| 12APX | 5595758 | Ø12 x 10,440 mm |
| 12APX-192 | 5595760 | Ø12 x 11,660 mm |

Grasp the cable coil firmly and remove the cable binding tie.

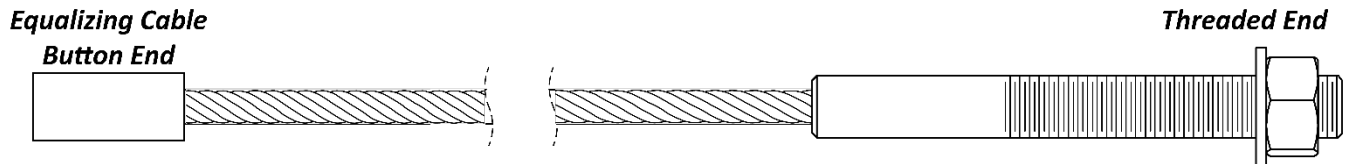

3. Uncoil, and then route the threaded end of the cable to the top of the lift post.
4. **Coil the equalizing cable and secure with heavy-duty tape or a cable tie at the top of the lift post until called for later in the assembly process.**
5. Repeat steps 1 through 5 on the remaining equalizing cable and lift post.
6. Ensure both lift heads are down at the bottom of each post.
7. Verify the cylinder Clamps are secured in place above the hydraulic cylinders.

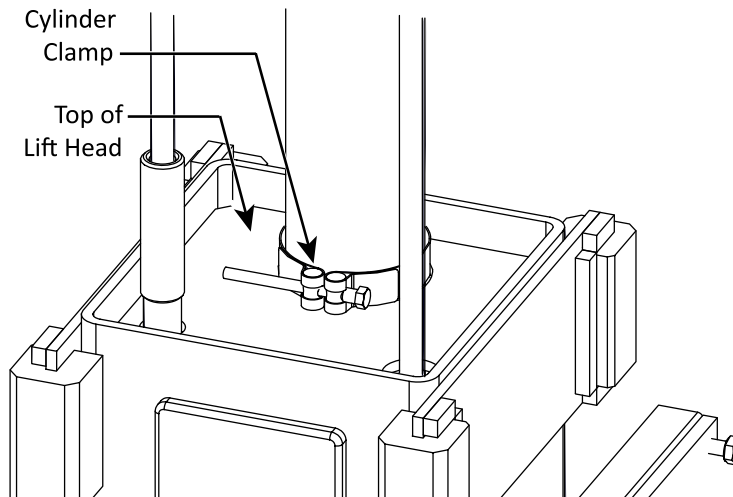

⚠ WARNING Verify the cylinder Clamps are positioned at the top of the lift head and secured. **Do not operate the Lift if the cylinder Clamps are not secured on the hydraulic cylinders.**

Important

If you are having problems with the button end escaping its cable stop, try pushing the button end past the button stop and out the Hole at the top of the lift plate, then moving the equalizing cable around to get the cable into the slot. Once the cable is in the Slot, pull back on the other end of the cable to slide the button end into the slot. Try to keep the cable taut until the equalizing cable is connected at the other end later in the installation.

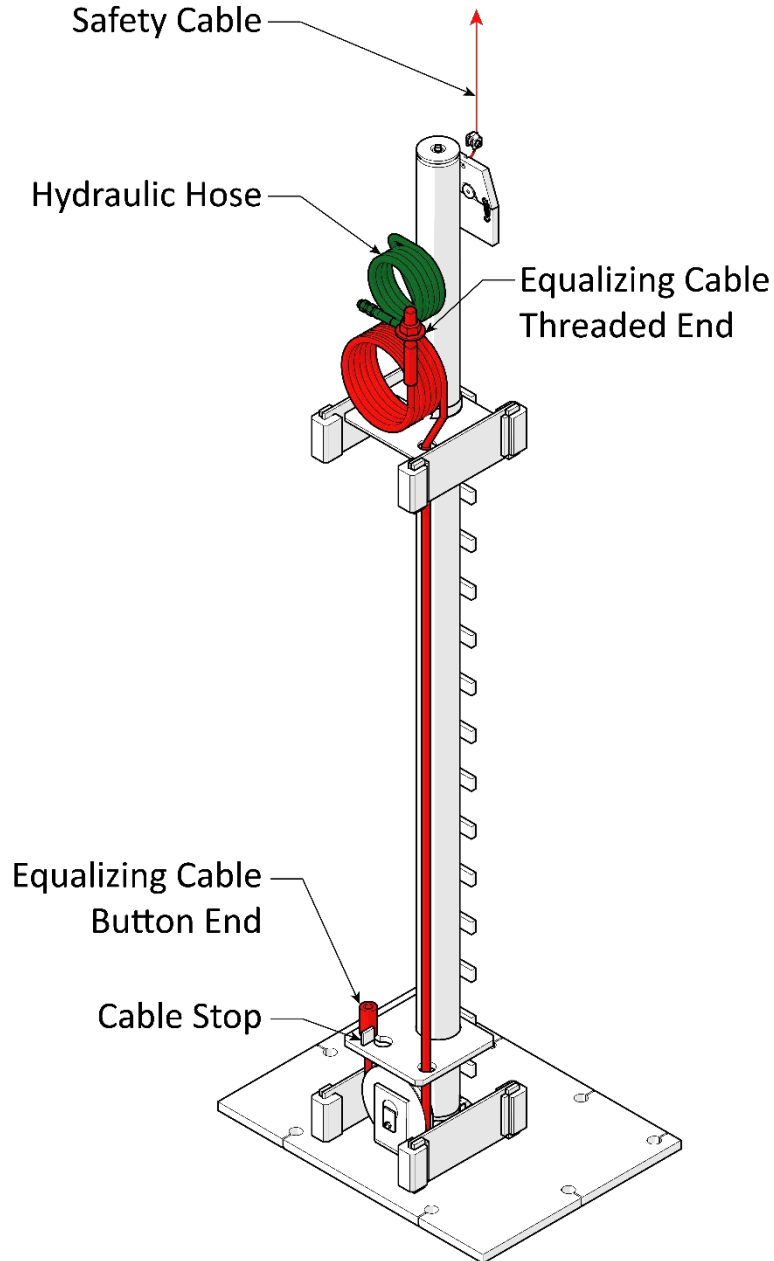

Equalizing cable shown coiled at the top of the lift head. Components removed for clarity.

Route and Position the Hydraulic Hoses

Move the hydraulic hoses into position **before** standing up the lift posts.

1. Arrange both posts either flat on the ground or elevated on sturdy work supports. The **insides** of the posts must be accessible, facing up.
2. Begin with the off side lift post. Locate the hydraulic hose coiled and stowed in the lift post. This hydraulic hose is preconnected to the hydraulic cylinder.
3. Cut or remove the cable tie binding the hydraulic hose and uncoil the hose routing it up to the top of the off side lift post.
4. **Coil the remaining hydraulic hose and secure with heavy-duty tape or a cable tie at the top of the off side lift post until called for later in the assembly process.**
5. Move to the power side post. The hydraulic hose is coiled and stowed in the lift post, but this cylinder includes a bulkhead tee.
6. Cut or remove the cable tie binding the hydraulic hose and uncoil the hose routing it up toward the top of the power side lift post.
7. Remove the protective cap and bulkhead nut on the long side of the tee.
8. Install the tee in the lift post and secure finger tight with the nut. Refer to the figure below. Insert the hose into the clips and then lightly bend or crimp to secure the hose in the post.
9. Return the protective caps to the tee fitting to keep contaminants out of the hydraulic system while assembling the Lift.

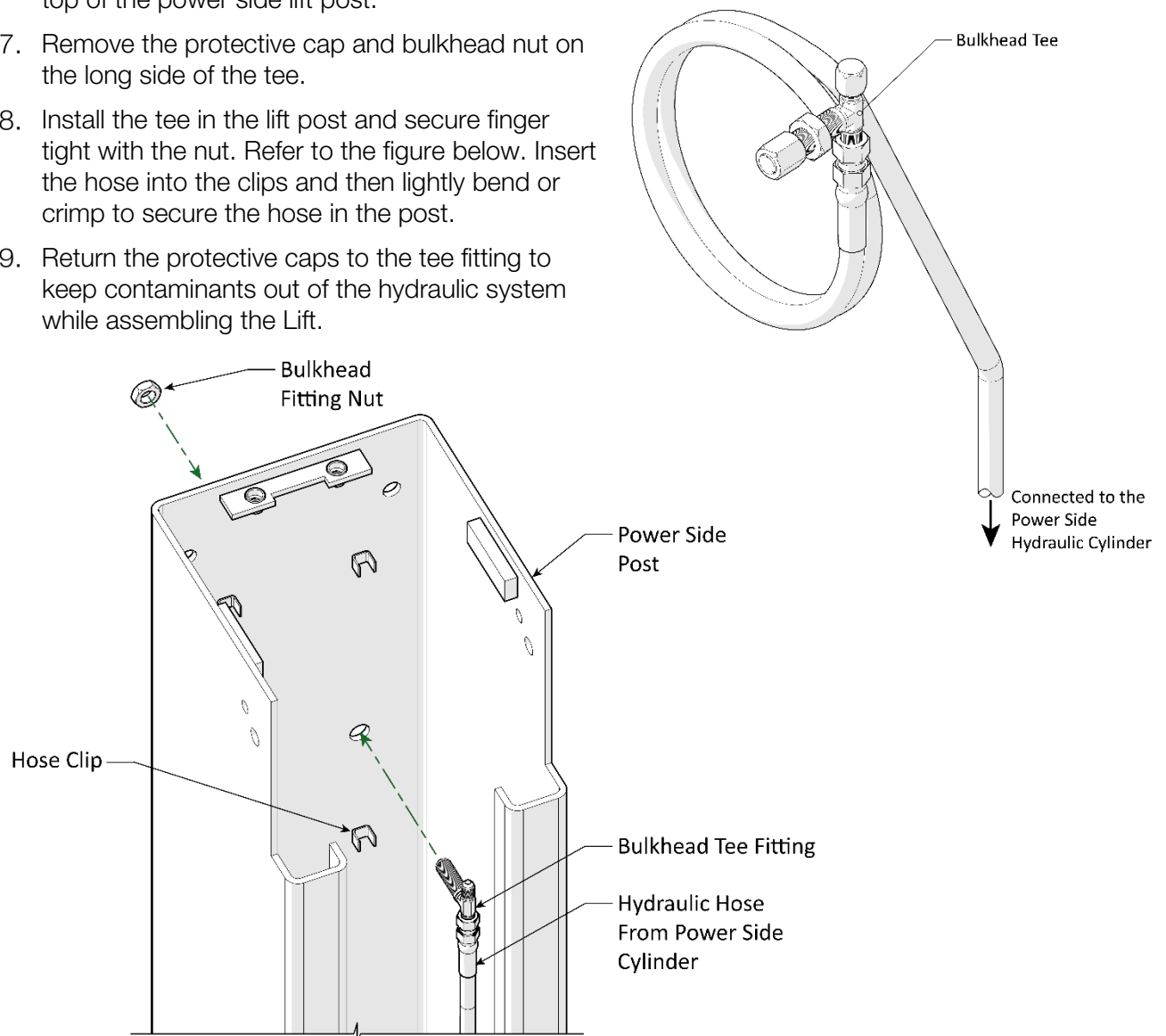

Create Chalk Line Guides

Based on the specifications for this Lift, create Chalk Line Guides on the ground for the two posts prior to moving them into position.

Use the **Overall Width** value in **Specifications** for this Lift model to determine where to place the chalk line guides. The Overall Width value is defined as the distance from the back of one base plate to the back of the other base plate.

The following illustration shows how to create Chalk line guides for a 12APX Series Lift.

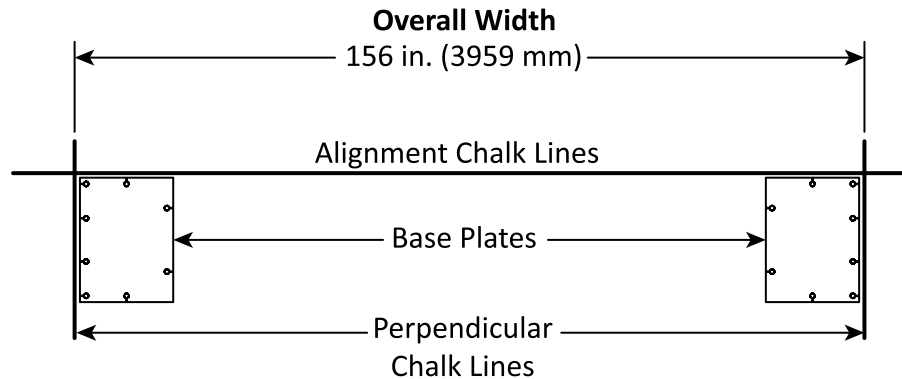

Top view of the base plates. Not all components are shown.

Create the Chalk Line Guides:

1. Decide where the Lift will be located. Verify the clearances around the Lift area.
2. Create an alignment chalk line at the Front of the Lift.

Make the alignment chalk line longer than the **Overall Width** setting for your Lift model.

3. Create two perpendicular chalk lines at 90° angles to the alignment chalk lines at the **Overall Width** distance for the 12APX of **156 in. (3,959 mm)**.
4. When moving the posts into position, put the base plates into the corners created by the chalk line guides, as shown in the figure above.

Raise and Anchor the Lift Posts

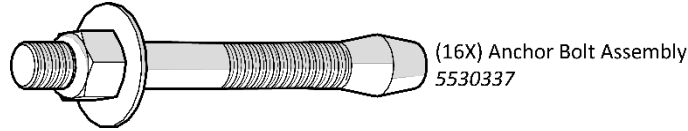

⚠ DANGER

Pay special attention when installing the posts. If done incorrectly, the Lift could fall over, potentially causing damage to the vehicle, the Lift, and/or injuring bystanders. BendPak strongly recommends consulting a Concrete Specialist early in your planning process for Lift installations. A Concrete Specialist will make adjustments to account for national, state, and local building codes as well as local weather conditions, soil composition, base preparation, load bearing, seismic requirements, and any other structural concerns that may arise.

Concrete specifications:

- **Depth:** 6 in. (150 mm) thick, minimum, steel reinforced.
- **PSI:** 3,000 PSI, minimum
- **Cured:** 28 days, minimum

Anchor Bolt specifications:

- **Length:** 6.3 in. (160 mm)
- **Diameter:** 0.75 in. (19 mm)
- **Anchor torque:** 85 – 95 pound feet
- **Effective embedment:** 3.25 in. (82.5 mm) or more

The concrete floor where the Lift will be installed must meet the following requirements:

- The floor must be a flat, level concrete floor. ***Do not install the Lift on a surface with more than three degrees of slope.***
- Do not install the Lift on cracked or defective concrete.
- Check the floor for the possibility that it could be a post-tension slab. In this case, contact the building architect before drilling. Contact a qualified professional to locate the tensioned cables before drilling.

⚠ DANGER

Cutting through a tensioned cable can result in injury or death. Do not drill into a post-tension slab unless the building architect confirms you are ***not*** going to hit a tensioned cable, or you have located it using ground penetrating radar. ***If colored sheath comes up during drilling, stop drilling immediately.***

⚠ DANGER

The concrete and anchor bolts ***must*** meet these specifications. Only install your Lift on a concrete surface. If you install a Lift on asphalt or any other surface, or your concrete or anchor bolts do not meet these specifications, it could lead to product damage, vehicle damage, personal injury, or even loss of life.

BendPak Lifts are supplied with installation instructions and concrete fasteners meeting the criteria as prescribed by the latest version of the American National Standard “Automotive Lifts – Safety Requirements for Construction, Testing, and Validation.”

⚠ WARNING

Use ***only*** the ALI-certified anchor bolts delivered with the 12APX Series Two-Post Lift. If components from a different source are used, the warranty is void and it may compromise the safety of everyone who installs or uses the Lift.

Lift buyers are responsible for conforming to all regional, structural, and seismic anchoring requirements specified by any other agencies and/or codes, such as the Uniform Building Code and/or International Building Code.

NOTICE Consider *not* torquing the anchor bolts into position yet. Installing the overhead assembly and doing final leveling may be easier if there is some play in the posts. Torque to specification after final leveling.

Effective Embedment

is the location in the hole where the expansion sleeve presses into the concrete. This is where the anchor bolts get their holding strength, the farther down into the hole, the greater the holding strength.

Nominal Embedment

is how far down into the hole the bottom of the anchor bolt is, which does not tell you anything about the holding strength.

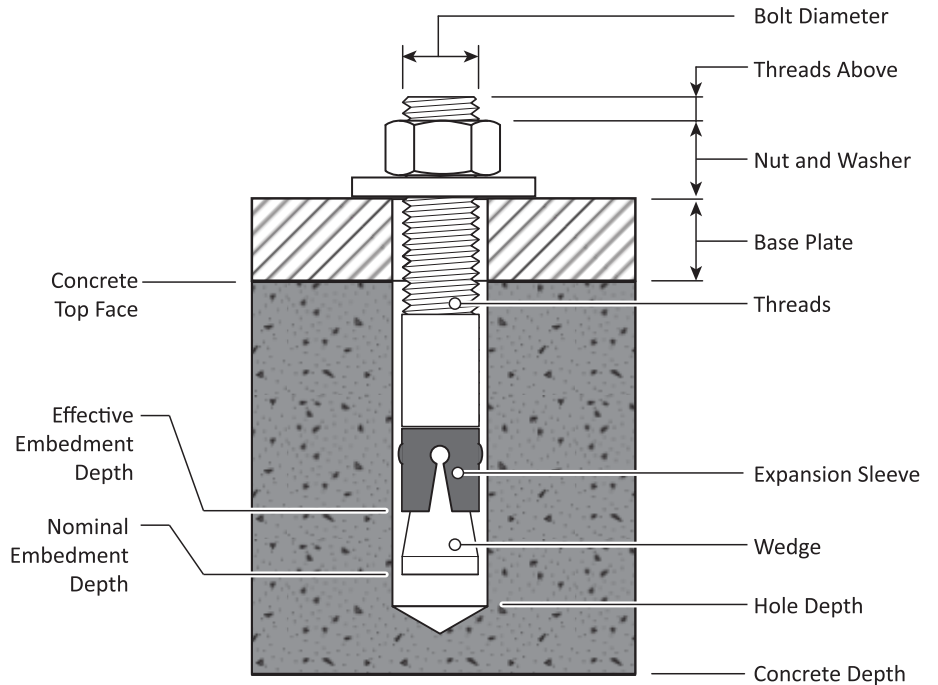

To Raise and Anchor the posts:

⚠ WARNING Verify the cylinder clamp is in place above the lift head **prior** to raising the Lift posts.

⚠ WARNING ***Pinch and crush hazards! Keep hands and feet clear of the lift head and lift post as it is raised.*** You **must** use the appropriate CE Marked safety gear including safety glasses, dust masks, gloves, steel-toed work boots, and heavy work clothes when anchoring the posts.

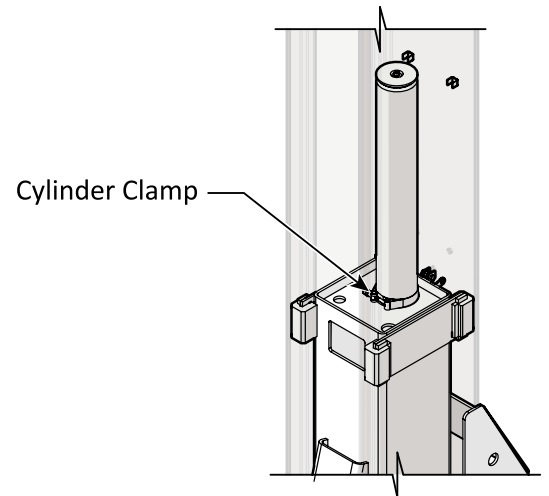

1. Using a forklift or shop crane, move the posts to the chalk line guides created earlier. Carefully stand up each post, *one at a time*, and move them to the appropriate location.

⚠ WARNING Many of the Lift components are heavy and awkward to work with. Installation should be accomplished by competent personnel ensuring all heavy components are properly rigged and balanced for lifting. Installation personnel should have knowledge, training, and experience in lifting, rigging, and securing heavy objects.

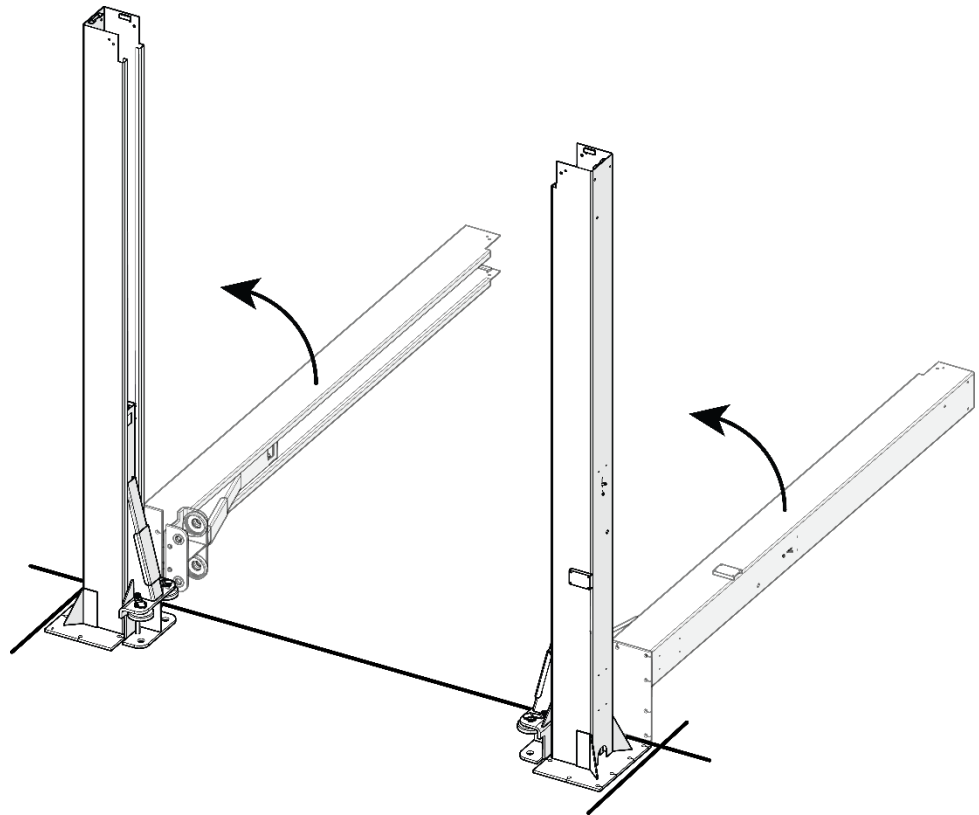

2. Double check the chalk line measurements against the **Specifications** for the Lift model.

⚠ WARNING You **must** wear the appropriate personal protective CE marked safety gear including safety glasses, dust masks, gloves, steel-toed work boots, and heavy work clothes when anchoring the posts.

- Using the base plates as guides, drill each hole to a depth of **5 inches min. (127 mm)** using a masonry drill bit. Drill into the concrete straight; do not let the drill wobble.

The diameter of the drill bit must be the same as the diameter of the anchor bolt. Ensure the drill flutes are at least as long as the depth of the hole to effectively remove material during drilling.

Drill a pilot hole! Pilot holes allow straighter, cleaner drilling by removing the material directly from the center of the final drill. This reduces the amount of force required to keep the final drill straight and perpendicular to the floor.

If the drill hits rebar embedded in the concrete and the hole is not ruined, by making it too big or out of round, switch to a rebar cutting drill bit. Slow the drill speed to avoid overheating the drill bit. Continue drilling until the drill passes the rebar.

Do not rush. Pull the drill out of the hole frequently to remove debris and clear the opening.

Do not drill all the way through the concrete; if the drill punches completely through the slab, you could compromise the holding strength of the anchor bolts.

- Vacuum each hole clean. BendPak recommends using a vacuum to get the hole very clean.

A wire brush, hand pump, or compressed air may also be used. **Make sure to thoroughly clean each hole.**

Do **not** ream the hole. Do **not** make the hole any wider than the drill bit made it.

⚠ WARNING **Always use the appropriate safety gear** including safety glasses, dust masks, gloves, steel-toed work boots, and heavy work clothes when anchoring the posts.

NOTICE The holding strength of an anchor bolt is partially based on the how cleanly the expansion sleeve presses against the concrete. If the hole is dirty or too wide, there is a reduction in holding strength.

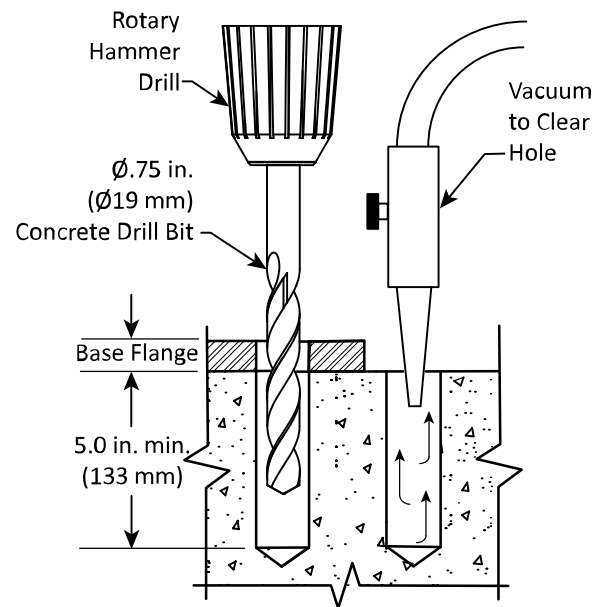

5. Make sure the Washer and Nut are in place, then insert the anchor bolt into the hole. The expansion sleeve of the anchor bolt may prevent the anchor bolt from passing through the hole in the Base Plate; this is normal. Use a hammer or mallet to get the Expansion Sleeve through the Base Plate and into the hole.
6. Even using a hammer or mallet, the anchor bolt should only go into the hole part of the way; this is normal. If the anchor bolt drops in with little or no resistance, the hole is too large.
Hammer or mallet the anchor bolts the rest of the way down into the hole and stop when the washer is snug against the Base Plate.
7. Verify each post is plumb. Install Shims as required. See **Leveling** and **Troubleshooting Lift Arm Lock Disengagement** if you are required to shim $\geq .5$ in. (13 mm).
8. Retrieve and install the foot guard and adapter holders on the posts as shown below.

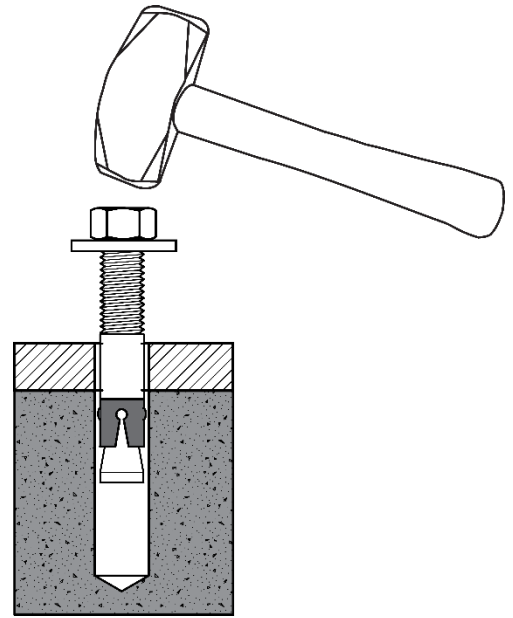

| Item | Part Number | Description | Qty. |
|----------|-------------|--|---------|
| A | 5535135 | Nut, 3/4-16 NL | 1 |
| B | 5545170 | Washer, 3/4 x 2 in. Flat | 1 |
| C | 5701901 | 12APX Foot Guard | 1 |
| D | 5545535 | C Washer, Shim <i>Do Not Exceed 0.5 in. (13mm)</i> | As req. |
| E | 5701660 | Height Adapter Holder | 2 |
| F | 5530065 | BHSK Screw, M6 x 20 | 4 |

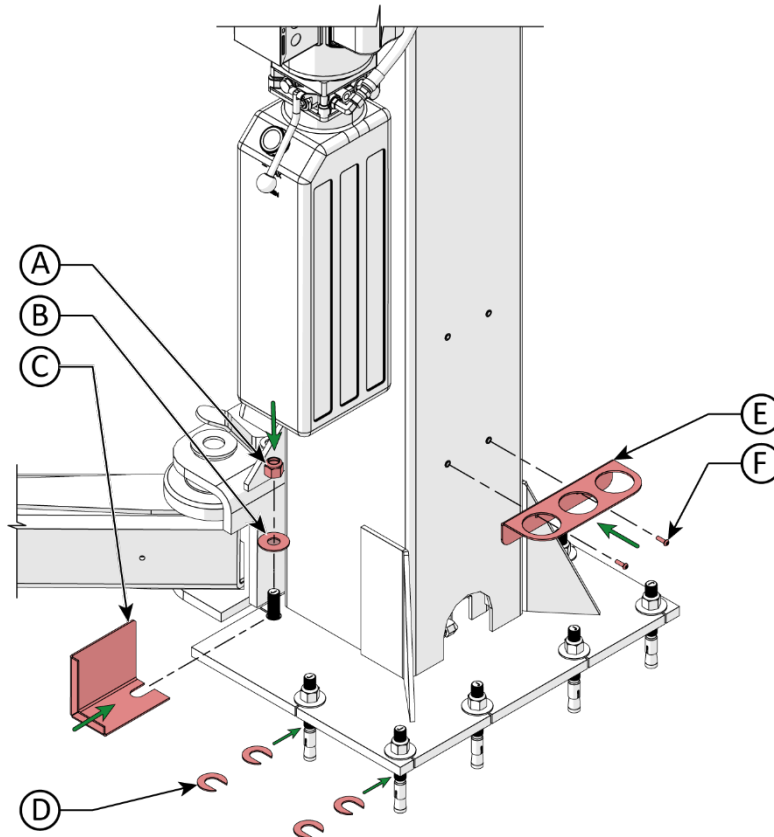



Tip

If planning to torque the anchor bolts later, so that installing the overhead assembly and final leveling is a little easier, skip the next step. Ensure the anchor bolts are securely in position. This will ensure that the posts will not move too much during the rest of the installation.

9. Tighten each Nut **clockwise** to the recommended installation torque, 85 – 95 pound feet, using a Torque Wrench.



CAUTION

Do **not** use an impact wrench to torque the anchor bolts.

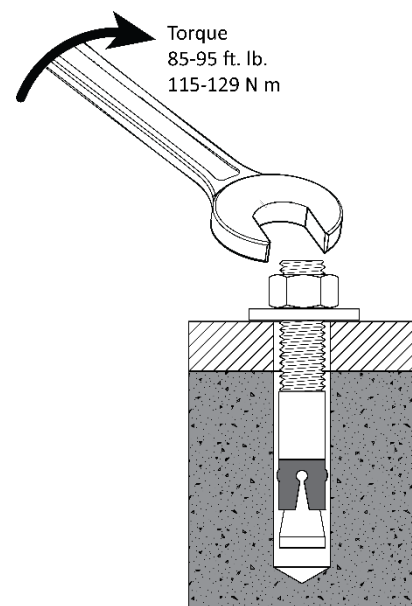

Install the Overhead Assembly and Limit Switch

The overhead assembly is installed above and between the power side and off side posts. It supports the equalizing cables, the hydraulic hoses, the limit switch wiring, and the safety lock cable.

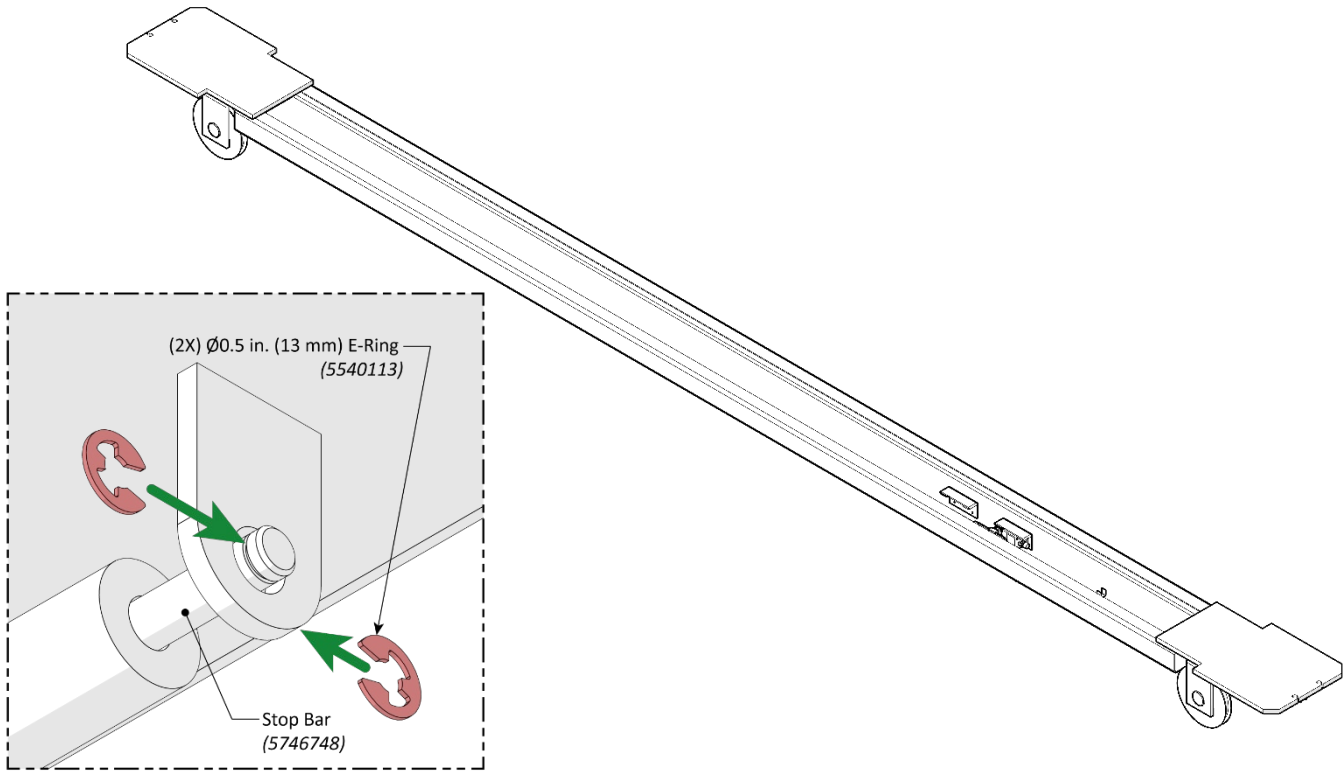

The overhead assembly, the safety shutoff bar, and limit switch are assembled at the factory. Two E-Rings secure the safety stop bar.

To prepare and install the overhead assembly:

1. Remove any protective packaging and all four overhead sheaves from and their pins from the ends of the overhead assembly. Keep the sheaves and components nearby.
2. Attach the stop bar to the overhead assembly, as shown below; use the same type of M12 hardware to secure the other end of the Stop Bar.
3. Use an appropriate lifting device to move the overhead assembly into position at the top of the Lift posts, **making sure to position the Limit Switch on the same side as the power side post.**
4. Bolt the overhead assembly to the top of the posts using two M10 bolts, and lock washers on both ends.

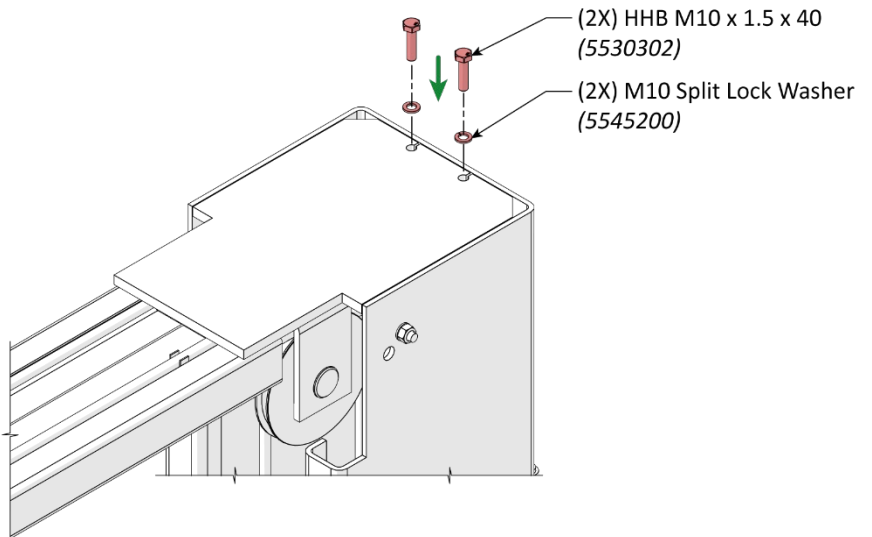

5. The overhead assembly must be installed to place the limit switch closest to the power side post.
6. The limit switch must be positioned so that the safety shutoff bar, when moved upwards, will contact the limit switch actuator arm.
7. Loosen the arm rotation set screw and rotate the arm downwards until it contacts the safety shutoff bar in its rest position. If necessary, adjust the arm length by loosening the arm length set screw. The limit switch should be free to travel and follow the safety shutoff bar as it moves up and down. Refer to the figures below.

Leave enough of the 14-2 cable near the switch and near the power unit for the Electrician to make the connections.

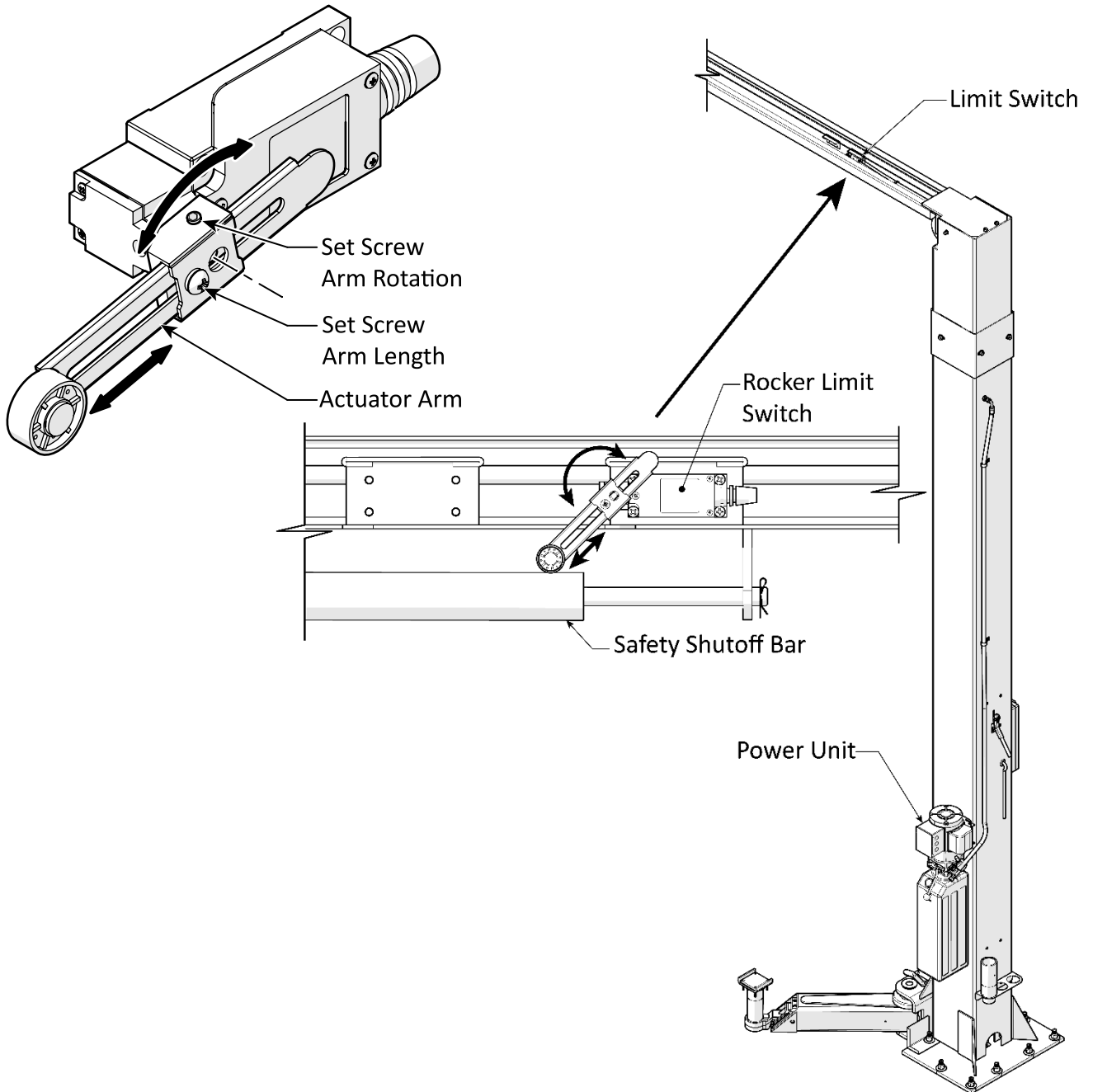

8. Retrieve the limit switch cable (5520032) from the parts box.
9. Route the cable as shown below. Secure the cable with the clips on the overhead and inside the power side post. Do not connect the cable to the limit switch. The Electrician will accomplish this task. Route the cable and leave enough cable near both the switch and the power unit for the Electrician to make the connections.

The limit switch cable exits the power side lift post below the safety release through a cable grommet and is then routed to the control box. Ensure there is enough cable to reach the control box that will be mounted above the power unit.

⚠ WARNING Ensure all cables and hoses are secured in their clips. All cables and hoses must be tight and flat inside the lift posts and routed to avoid moving components and pinch points.

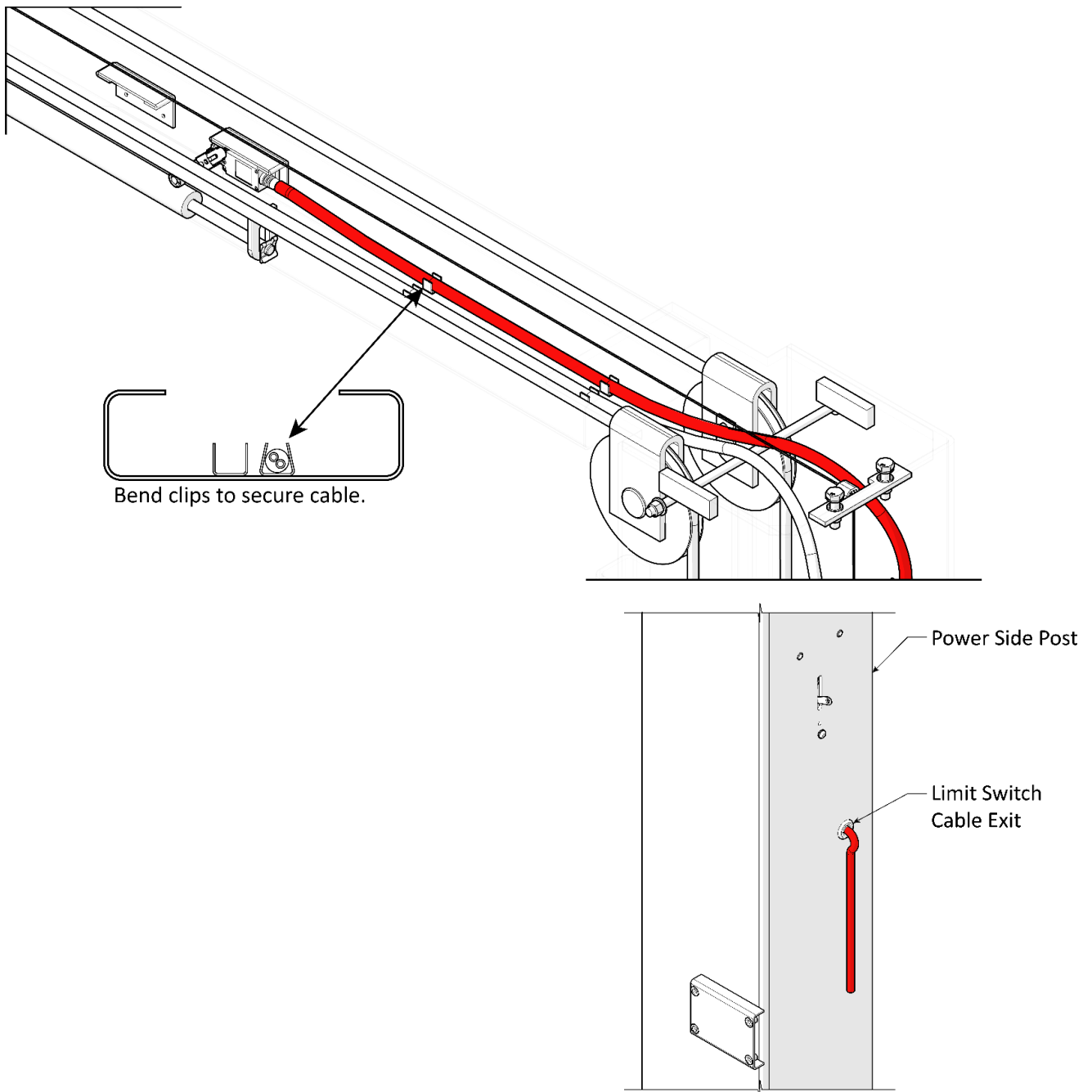

Install the Safety Lock Cable

The safety lock cable and the safety lock cable release handle are used to release the safety locks, allowing the Lift to be lowered.

The safety lock cable should have been coiled and left at the top of the lift post in the **Route and Position the Safety Lock Cable** section,

The figure below displays the path the safety lock cable travels from Safety assembly on the off side post to the Safety assembly on the power side post.

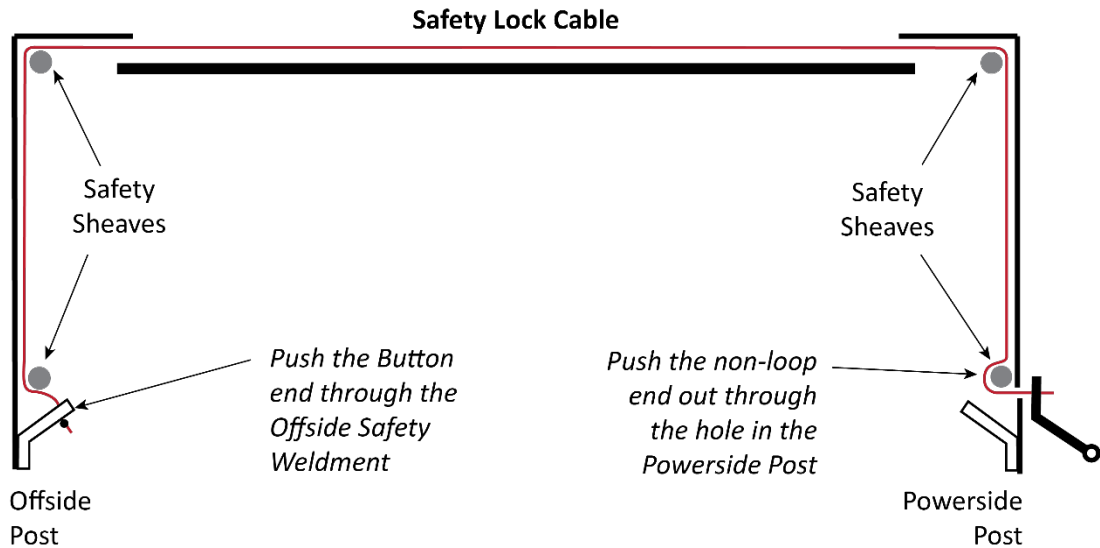

Not drawn to scale. Some components exaggerated or not shown for clarity.

The following illustration shows the safety lock cable connections to the safety assemblies.

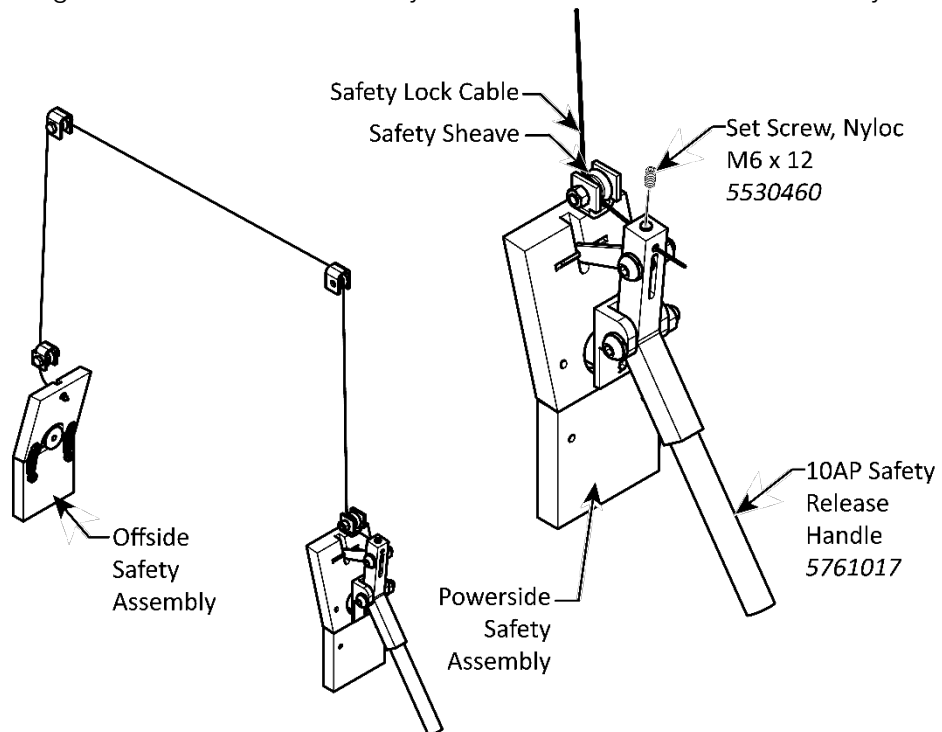

Reference only – do not scale.

⚠ WARNING Access to the overhead assembly is required to route the safety lock cable. Use care to avoid falling when working on a ladder or other lifting device.

To route and connect the Safety Lock Cable:

1. Locate the safety lock cable. This should be coiled at the top of the off side post.
2. Route the non-button end under the safety sheave, upwards on the inside of the off side post, up and over the safety sheave at the top of the off side post, across the overhead assembly, over the safety sheave at the top of the power side post, and then downwards, on the inside of the power side post, towards the power side safety assembly.
3. **Switching to the power side post**, route the non-button end of the safety lock cable through the safety sheave.
4. Temporarily remove the M6 set screw (5530460) that is loosely secured in the safety lock cable release handle.
5. Route the safety lock cable through the hole in the safety release handle and apply tension, then replace the set screw. Tightly secure the connection.
6. Install the Safety Cover (5716072) and pipe strap (5550492) on the power side post using two Button Head M6 x 20 screws (5530065). There is no safety cover for the off side post. Position the pipe strap to secure the hydraulic hose.
7. Ensure the safety lock release functions by checking for freedom of movement and observing the safety locks.

⚠ DANGER Verify both the power side and off side safety assemblies engage properly **before** operating the Lift.

⚠ CAUTION Verify the safety lock cable stays on its Safety sheaves; this keeps it out of the way of the equalizing cables and the hydraulic hoses.

Figure not to scale. Components removed for clarity.

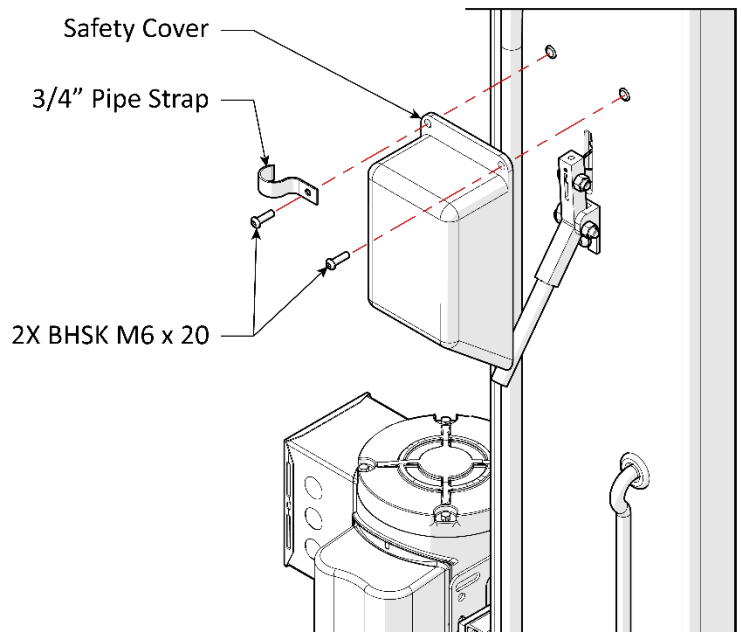

Complete the Equalizing Cables Installation

Both equalizing cables should have been put into position coiled at the top of the Lift posts before the posts were raised, which is covered in [Move the Equalizing Cables into Position](#).

This section picks up where that section left off: the button ends of the equalizing cables (on both posts) have been installed, routed around the post sheaves, and then pushed up above the lift head. They now need to be routed over the overhead assembly and then down to the top of the lift head.

NOTICE If the equalizing cables are not yet in position, put them into position before performing the following procedure.

When equalizing cables are fully routed, they are mirror images of each other. Refer to the figure below for both the 12APX and 12APX-192.

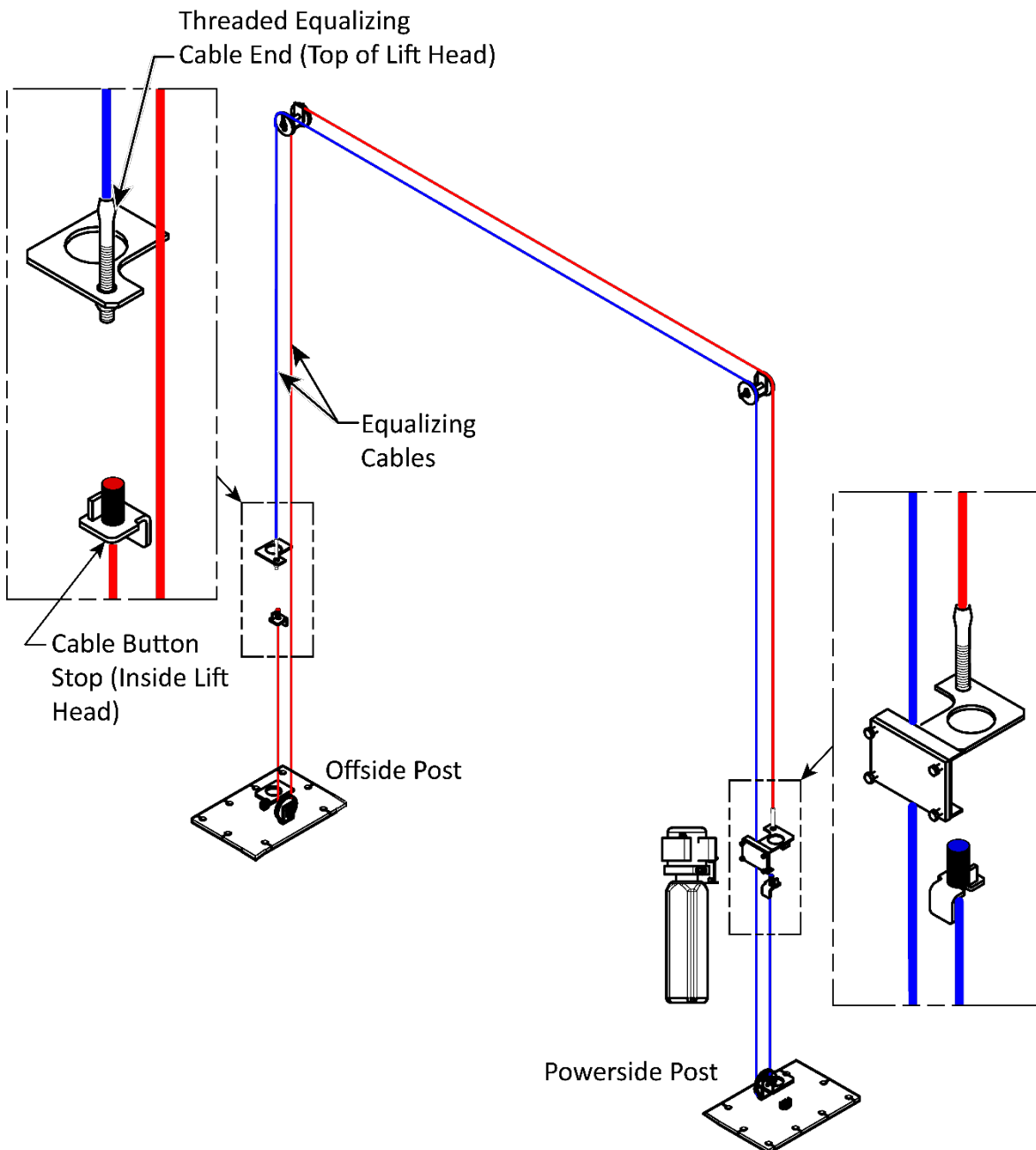

Components removed for clarity.

To Complete the Equalizing Cable Installation:

1. Using a forklift or shop crane, manually raise both lift heads about 28 in. (711 mm) off the ground and **engage them on the closest safety lock**.

Measure to verify both lift heads are the same distance off the ground.

⚠ WARNING You must use safety stands to block and prevent the lift head downward movement while working under it.

⚠ WARNING You must use a proper lifting device such as a forklift or shop crane to raise and position the Lift components. Make sure the button ends of both equalizing cables are still in the slots in their cable button stops, that both equalizing cables go under the post sheave in their posts.

2. If either cable is not correct, correct it at this point; do not continue until the equalizing cables are in their correct starting position.

Choose which one of the two equalizing cables are to be put into position first, then remove the nut from the threaded end of that cable.

NOTICE The overhead assembly sheave, sheave pin, and hair pin were previously removed. Remove these components, if present.

3. Route the threaded end of the equalizing cable up on the inside of the post, over the overhead sheave assembly, and then out over the top of the overhead assembly.

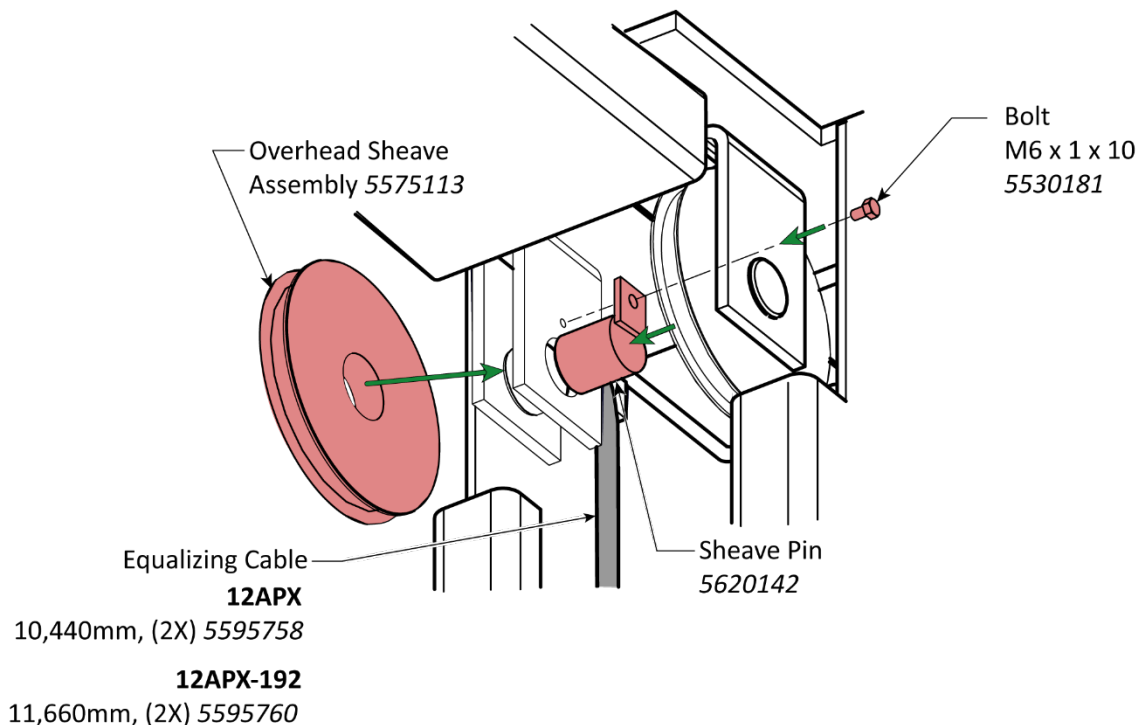

4. Lubricate the sheave pins and bearings with red lithium grease, then re-install the overhead assembly sheave, sheave pin, and hair pin.
5. At the remaining post, remove the nut from the threaded end of the other equalizing cable.

6. Route the threaded end over the top of both overhead assembly sheaves, and then down the post towards the lift head.
7. Lubricate the sheave pin and bearing with red lithium grease, then re-install the overhead assembly sheave, sheave pin, and hair pin.
8. Place the threaded end of the equalizing cable through the hole at the top of the lift head, then install the nut and securely tighten.

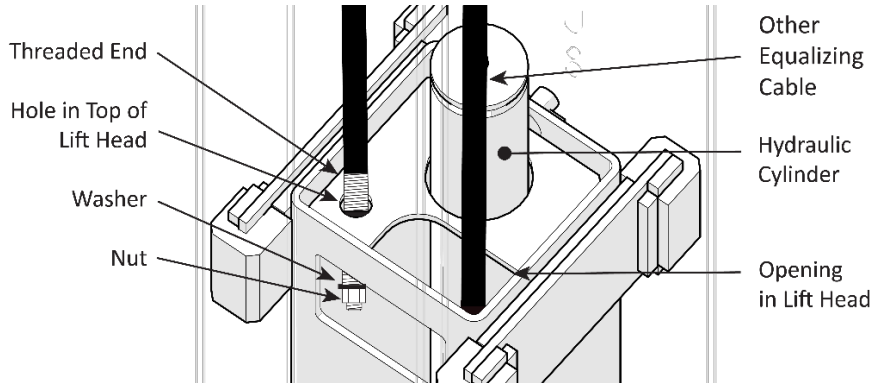

Reference only – do not scale.

9. Perform steps 3 through 8 for the remaining equalizing cable.

Double Threaded Rod Installation

The Double Threaded Rods (5746166) as shown below, must be installed with M10 flat washers (5545341) and M10 x 1.5 Hex Nuts (5535013) on each Lift post. Torque the Hex Nuts to 2-3 ft. lb. (2.7 – 4 Nm) *hydraulic hoses are to be routed over the double threaded rods as shown below.*

⚠ WARNING The double threaded rods must be installed to ensure proper operation of the Lift.

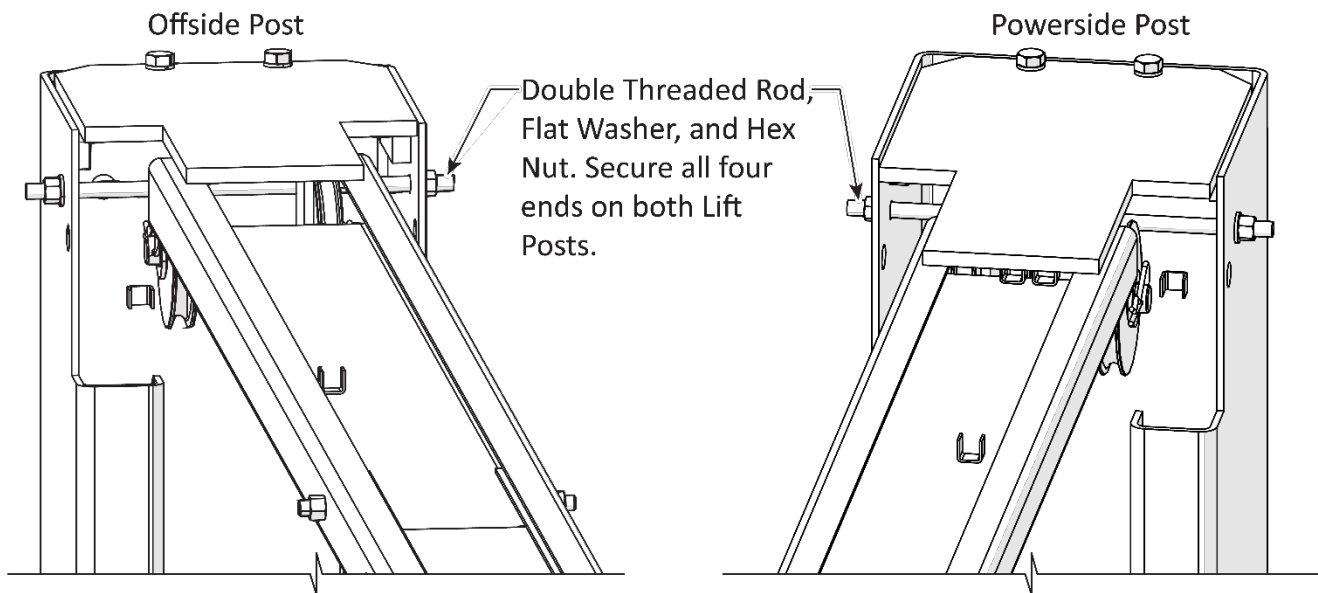



IMPORTANT! PLEASE READ NOW



Hydraulic Fluid Contamination poses a serious issue for your Lift, contaminants such as water, dirt, or other debris can make their way into the hydraulic hoses and fittings on the Lift, making the Lift inoperable and unusable.

This Lift is shipped with clean components; however, BendPak strongly recommends that you take secondary precautions and clean all hydraulic hoses and fittings prior to making connections. It is better and less costly to take these extra steps now so that there is no need to take the Lift out of service later to fix issues that could have been prevented at the time of installation.

There are several methods available to clean hydraulic hoses and fittings:

- **Compressed Air.** Use an air compressor to blow out contaminants from each hydraulic hose and fitting prior to installation. Clean, dry air is preferred. Wear CE Marked, or ANSI-approved eye protection (safety glasses, goggles, or face shield) when using compressed air for cleaning. Never point an air hose nozzle at any part of your body or any other person.
- **Fluid Flushing.** If the hydraulic fluid is clean and compatible with the system fluid, you can flush hoses and fittings to create turbulent flow and remove particulates. Always ensure that the fluid itself is contaminant-free.
- **Remove old thread seal tape.** Some ports on the hydraulic cylinders are shipped with temporary plugs secured with thread seal tape, so make sure to thoroughly remove any leftover thread seal tape that may inadvertently enter the hydraulic system.
- **Use a liquid thread sealant only.** Liquid thread sealant (Loctite™ 5452 or similar) is recommended. Do not use thread seal tape on any fitting. Liquid thread sealant is recommended for NPT connections, fine for JIC connections, but *not* necessary for O-ring (ORB) connections.
- **Always use clean equipment.** If you use a dirty bucket or funnel to transfer the hydraulic fluid into the hydraulic fluid reservoir, the contaminants will likely be introduced into the Fluid. When using cleaning rags, use a lint-free rag.
- **Proper storage.** Keep the hydraulic fluid sealed in its container until ready for use; store the Fluid in a clean, dry, and cool area.
- **Cover the Hoses and Fittings.** Before installation, do not leave the ends of the fittings exposed; the same applies for the hydraulic hoses. As a general rule, keep the hydraulic hoses and fittings capped and in a clean area until ready for use.
- **Filter new Hydraulic Fluid.** Just because it is new does not necessarily mean it is *clean*. Use an offline filtration cart or kidney loop system to make sure the hydraulic fluid is clean before being transferred into the hydraulic fluid reservoir (even using a heavy-duty nylon mesh screen is better than trusting what is left at the bottom of the barrel).
- **Avoid mixing different types of hydraulic fluid.** If hydraulic fluid needs to be replaced, make sure to flush the hydraulic system of the old hydraulic fluid before you add the replacement Fluid; do not mix the two together.

Hydraulic Oil Contamination Limits

Hydraulic oil cleanliness should be between 18/16/13 and 20/18/15 (ISO 4406).

About Thread Sealants

Liquid thread sealant lubricates and fills the gaps between the fitting threads and leaves no residue that could contaminate the hydraulic fluid.

Other types of thread sealants (like Teflon Tape) can shred during installation or removal and eventually enter the hydraulic system.

Thread sealant can be used with most hydraulic fittings, although it must be used with NPT connections.

Apply the thread sealant when the ambient temperature is between +46.5°F to +70°F (+8°C to 21°C).

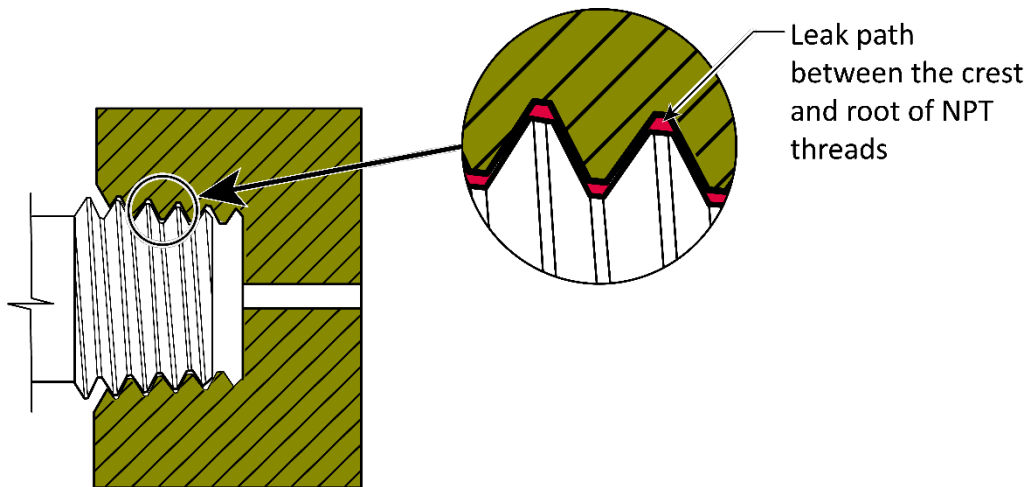

To apply the thread sealant:

1. Make sure the fittings and connectors you are going to use are clean and dry.

If you are adding thread sealant to a fitting or connector that has already been used with a different sealant, use a wire brush to thoroughly remove the old sealant before adding more.

2. Skipping the first thread, apply a small amount of thread sealant to the next four threads of the fitting.

⚠ WARNING Always wear the proper protective equipment when handling thread sealant.

Only a small amount of sealant is required. The sealant spreads to the other threads as it is tightened into place.

If too much is applied, the excess liquid will be pushed out when the fitting is tightened; use a rag to wipe the excess.

3. Tighten the fitting into the connector; do **not** over tighten the fitting.
4. Allow the **24-hour** manufacturer-recommended curing time before pressurizing the system.

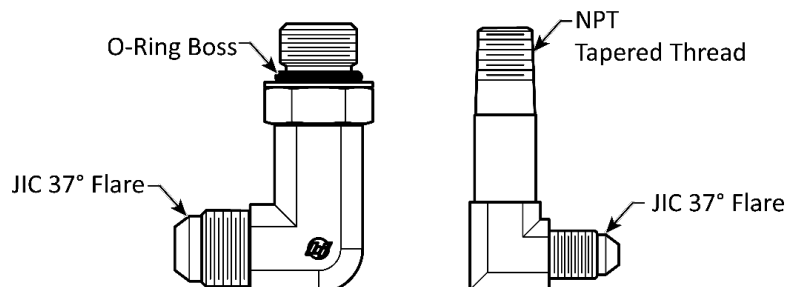

Hydraulic System Warnings

Before applying power to the hydraulic system, note the following Dangers and Warnings:

-  **DANGER** Failure to observe these warnings can result in serious personal injury including, in rare cases, death.
-  **DANGER** The power unit is a hydraulic pump capable of developing pressures in excess of 5,000 psi (345 BAR). A pressure relief valve is used to set the pressure at the desired level. Tampering with, adjusting, modifying, or removing the relief valve is extremely dangerous and is not permitted. Only trained hydraulics technicians are permitted to adjust the relief valve, using calibrated hydraulic pressure gauges to ensure the proper pressure setting is achieved.
-  **DANGER** Changes to the output pressure may render the power unit incompatible with pressure limitations of other components in the hydraulic circuit. This may cause catastrophic failure of those components, and could result in property damage, severe personal injury, or death.
-  **DANGER** The hydraulic system can contain high pressure which, if suddenly released, can cause severe injury or death.
-  **WARNING** The hydraulic hoses and connections **must** be inspected before any attempt to raise a vehicle is made.
-  **WARNING** **Ensure** all hydraulic hose connections and fittings, including unused auxiliary port plugs on the power unit, the Flow Divider, the cylinders and anywhere else in the hydraulic system are tightened.
-  **WARNING** Do **not** attempt to connect or disconnect hydraulic hoses while the equipment is loaded or while a vehicle is on the Lift or the hydraulic system is under pressure.
-  **WARNING** Keep bare hands away from hydraulic fluid; always wear gloves when handling hydraulic fluid, cylinders or hydraulic hoses.
-  **WARNING** BendPak does not supply hydraulic fluid or lubricants with this Lift. **Always** refer to the Safety Data Sheet (SDS) for safe handling and disposal information. SDS are available from the hydraulic fluid or lubricant supplier or manufacturer.
-  **WARNING** **Always** promptly clean any hydraulic fluid spills. If a leak is the source of the spill, lockout the Lift to prevent use until the hydraulic system is repaired.
-  **WARNING** **Check the hydraulic fluid level before each use.** Lower the lift arms to the ground and remove power from the Lift. Open the cap on the fluid reservoir to verify the hydraulic fluid level is in the safe for operation range. Refill, if required.

Mount the Power Unit

This section describes mounting the power unit to the power side post. An Electrician is not required to **mount** the power unit, but an Electrician is required to **connect** the power unit to the facility's electrical system. Refer to **Connecting the Power Unit** for electrical installation information and specific information about the power unit that came with your Lift.

NOTICE Do not connect the power unit to the hydraulic system or to the power source at this point in the installation; those connections will be made later.

CAUTION The power unit is heavy. BendPak recommends having one person hold the power unit while a second person bolts it into place.

To mount the power unit:

1. Retrieve the four M8 hex head bolts, M8 lock washers, and one vibration dampener supplied with the lift.
2. Remove the power unit from the packaging material.

Important The power unit is heavy. BendPak recommends having one person hold the power unit while a second person bolts it into place.

3. Move the vibration dampener into place next to the mounting bracket on the power side post.
4. Move the power unit mount plate next to the vibration dampener.
5. Secure the power unit and vibration dampener using the fasteners listed in step 1, using all four openings to secure the power unit. Refer to the figure below.

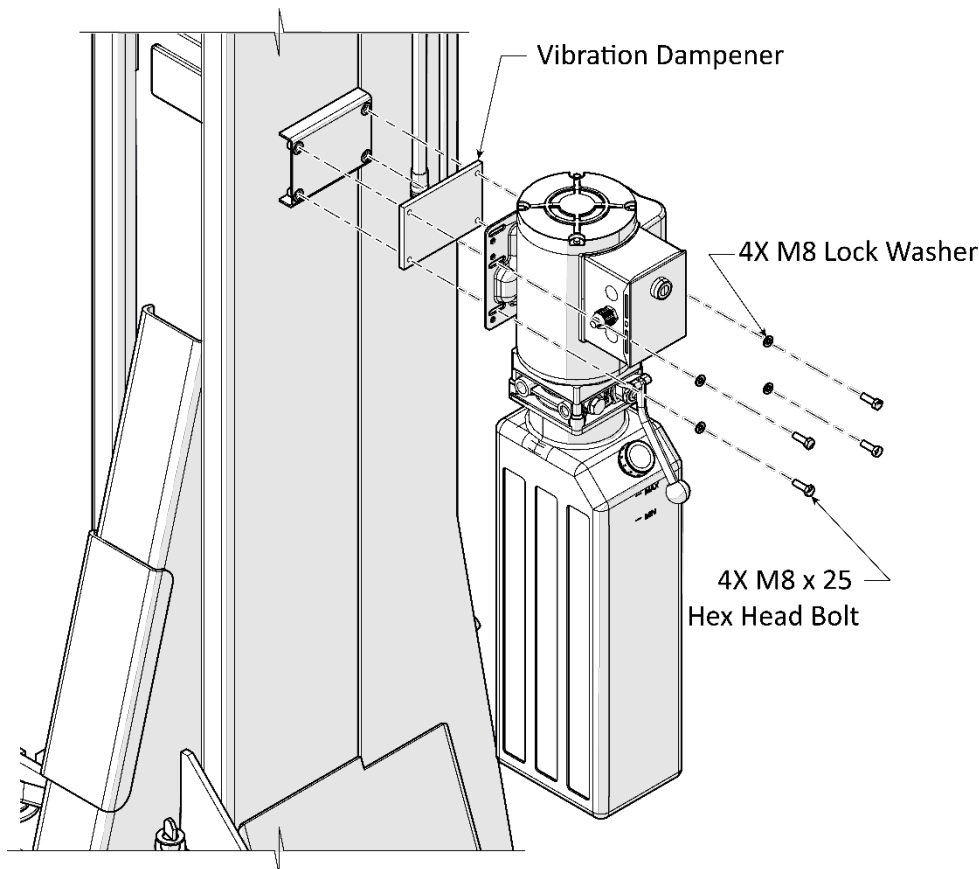

Complete Connecting the Hydraulic Hoses and Fittings

Some of the hydraulic hoses were put into place much earlier in the installation. If they were **not** put into position earlier, you must do so now, **before** beginning the following procedure. Refer to **Route and Position the Hydraulic Hoses** for full instructions.

| Lift Model | 12APX Hose size | 12APX Part No. | 12APX-192 Hose Size | 12APX-192 Part No. |
|---------------|--------------------|-------------------|------------------------|-----------------------|
| Hose A | Ø10 x 2,790 mm | 5570290 | Ø10 x 2,790 mm | 5570290 |
| Hose B | Ø6.4 x 3,870 mm | 5570238 | Ø6.4 x 3,870 mm | 5570238 |
| Hose C | Ø6.35 x 7,950 mm | 5570254 | Ø6.35 x 9,168 mm | 5570255 |

Hydraulic hoses and fitting locations are detailed in the figure below. Completed routing and locations shown for clarity. Lightly crimp the hoses in the clips welded to the lift posts and the overhead assembly to secure.

1. Remove all protective caps from the bulkhead tee fitting.

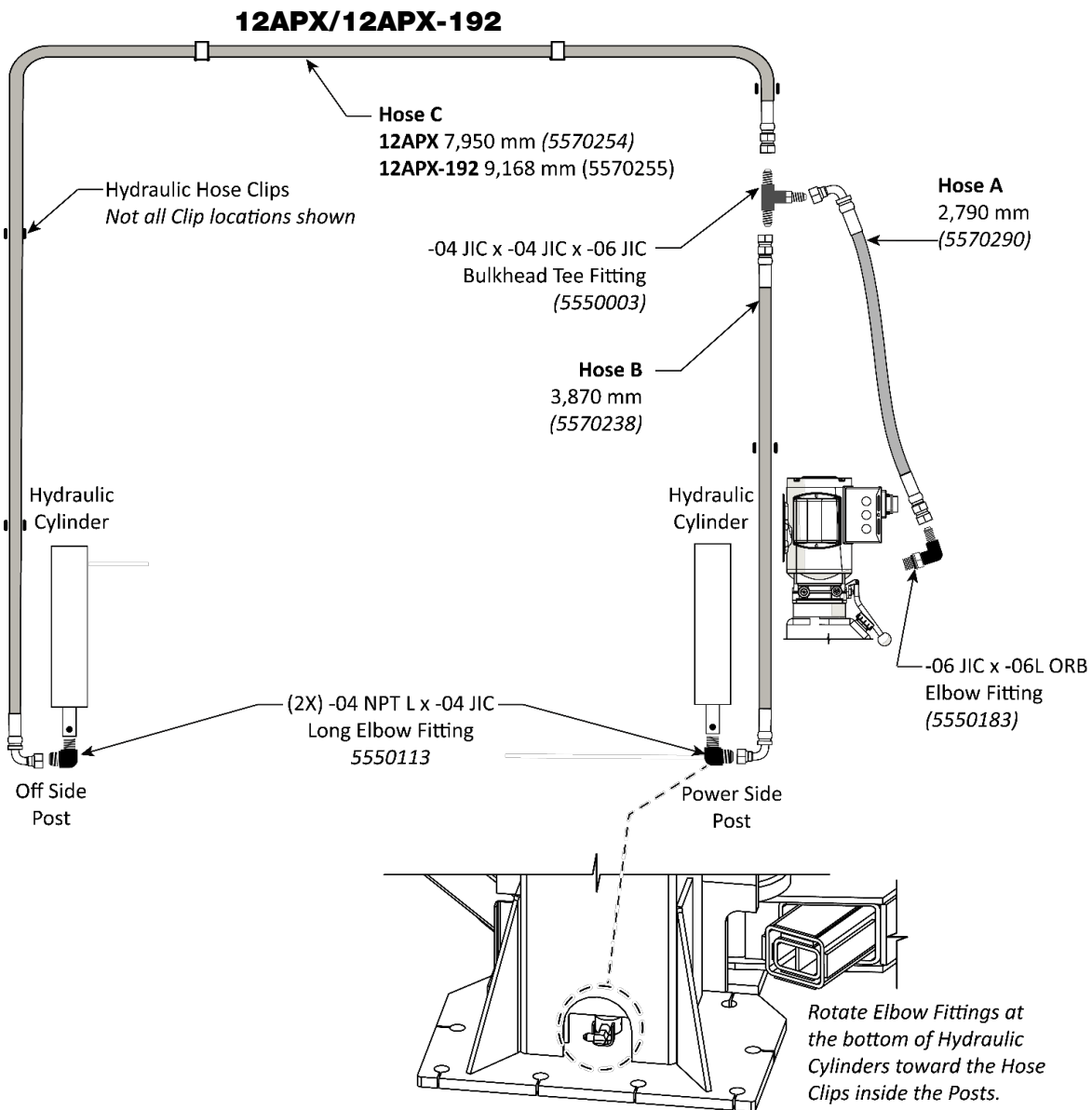

Figure for reference only.

- Retrieve the Ø10mm x 2,790 mm short hydraulic hose **A** and the remaining elbow ORB hydraulic fitting (5550183).
- On the power unit**, ensure that the hydraulic pressure port on the power unit has the shipping plug removed and install the elbow hydraulic fitting (5550183). Pressure ports are typically labelled P, P1 or P2.

IMPORTANT! Place a few drops of hydraulic fluid or silicone O-ring lubricant on the elbow's O-ring before installing on the power unit.

Note: There are multiple ports on the power units that are used with 12APX Series Lifts. However, each 12APX Series Lift *uses only one* hydraulic pressure port (labeled **P1** in the drawing below). Do **not** connect to any of the other ports and do **not** connect to more than one hydraulic pressure port. All other active ports should remain plugged. Ensure these plugs are tight.

- Tighten the elbow fitting appropriately. Leave the -06 JIC connector facing up, towards the bulkhead tee fitting on the power side post.
- Connect the curved end of the short hydraulic hose **A** to the bulkhead tee fitting; finger tighten this connection. This connection is made on the outside of the power side post. If the -06 JIC connector of the tee fitting is **not** on the outside of the power side post, this indicates the tee fitting was not installed correctly. Return to **Route and Position the Hydraulic Hoses** for more information.

CAUTION Do not overtighten JIC fittings! Damage to the hose or fitting is likely.

- Connect the straight end of the short hydraulic hose to the elbow fitting on the power unit. Finger tighten the connection.
- Switching to the off side post**, take the long hydraulic hose and route it over the overhead assembly towards the power side post, making sure to put the hose through the clips in the post.
- Connect the straight end of the long hydraulic hose to the -04 JIC connector facing up on the bulkhead tee hydraulic fitting; finger tighten the connection.
- Using appropriate tools, systematically check and tighten all hydraulic connections.**

IMPORTANT! Verify all hydraulic hoses are seated and secured in the clips on the inside of the Lift posts and will not interfere with any moving components.

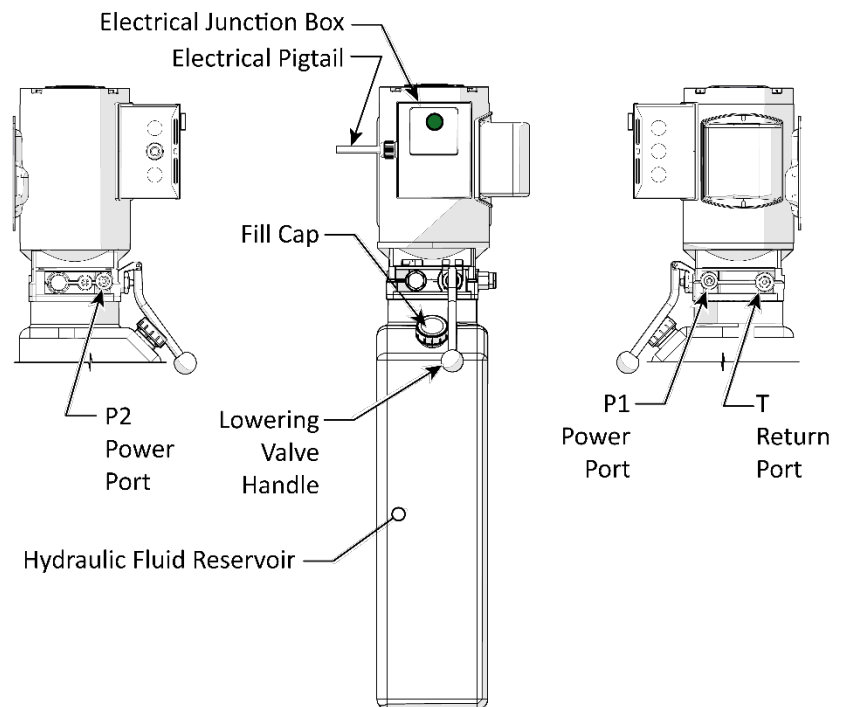

Completed Hose Routing

Power Side Post

Completed hydraulic hose routing shown below. Verify all cables and hydraulic hoses are flat and tight against the lift posts. Clear of all moving components inside the posts.

Secure the hydraulic hoses in the clips. Failure to secure the hoses in the clips may result in damaged or ruptured hydraulic hoses.

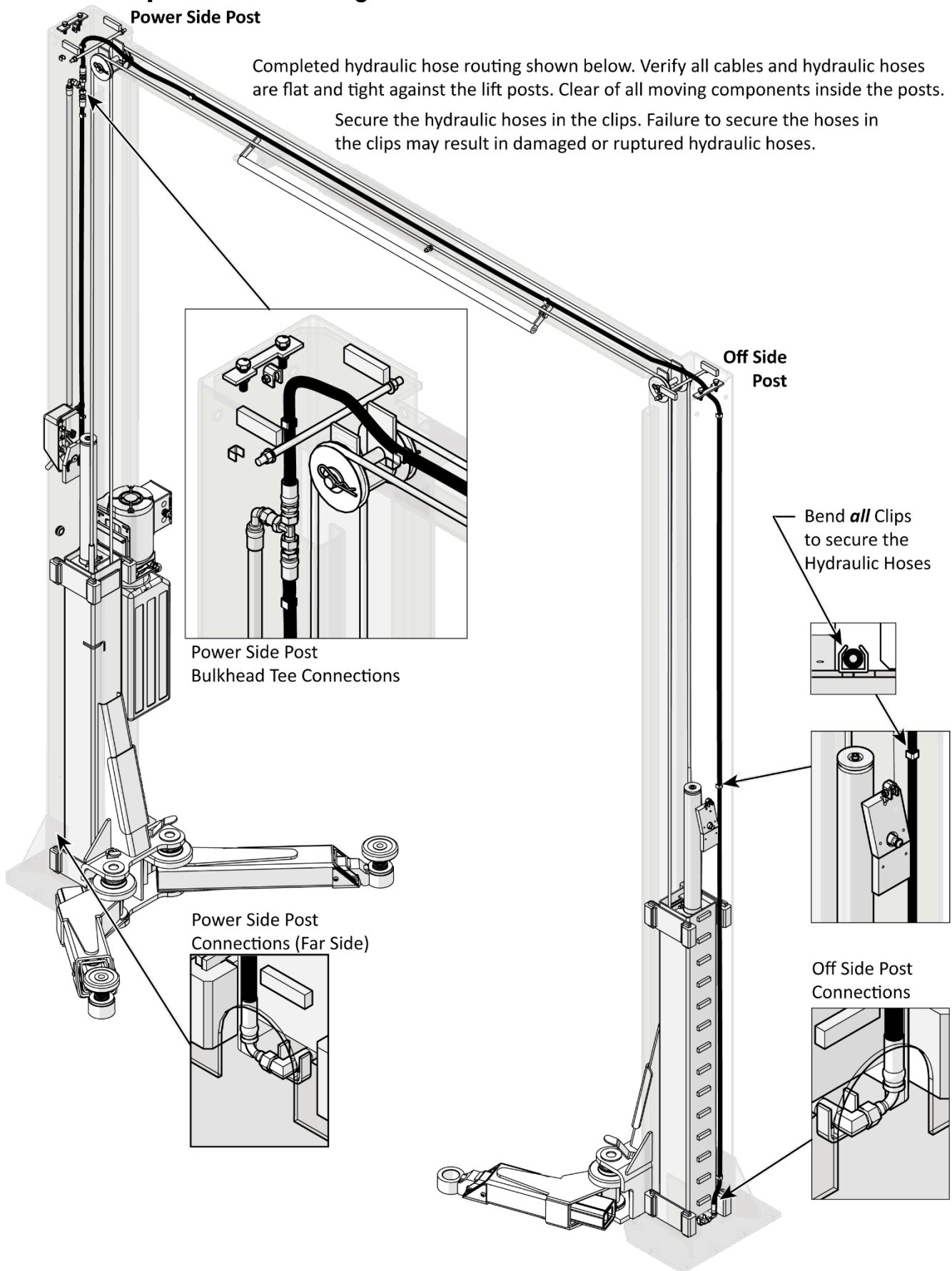

10. Retrieve the cable clamps and MX machine screws.

11. Secure hydraulic hose **A** between the bulkhead tee and the power unit. Refer to the figure below.

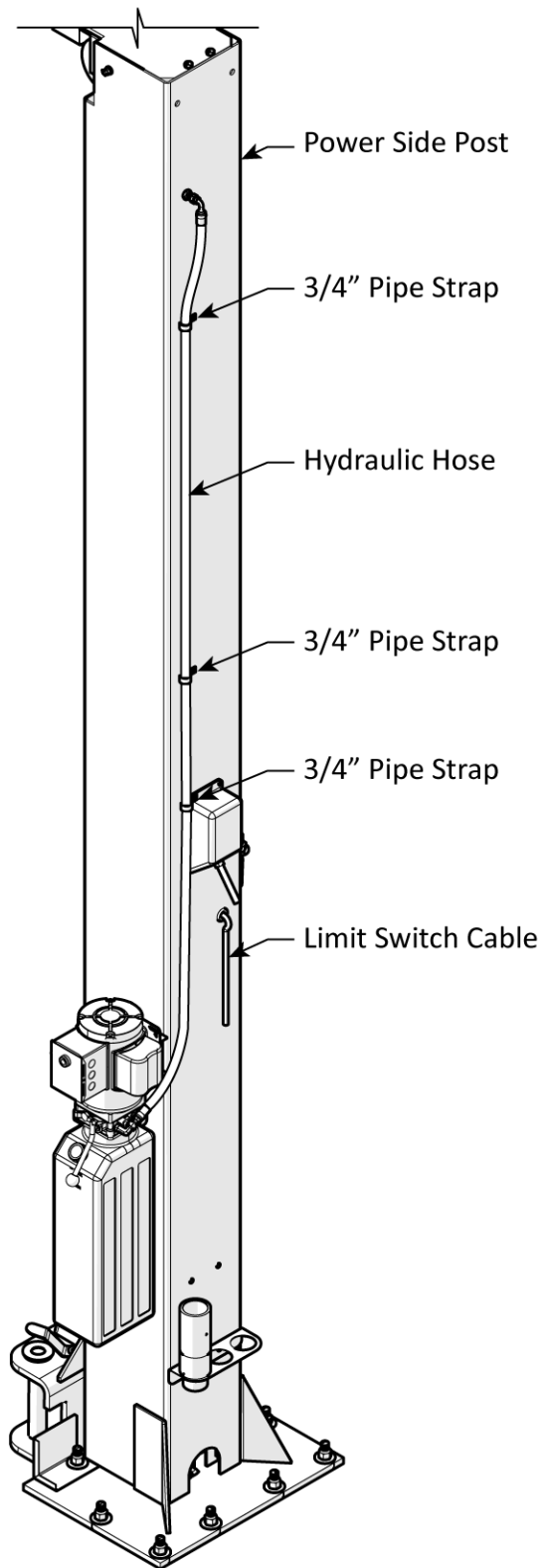

Install the Lift Arms

The 12APX Lift is delivered with four lift arms that are installed, as detailed in the following figures.

Observe the Front and Rear sides of the Lift as you have chosen to position them:

- If the vehicle can only drive in **one way**. The approach side is the rear, the other side is the front.
- If the vehicle can drive in **either way**. Choose one side as the front and the other side as the rear. The rear will be the dedicated approach direction for the vehicles you will be putting on the Lift; even though you can drive in either way. Also consider the ease of backing out from your chosen approach.

Next, set the arms in position and install each arm assembly. The front positions hold the asymmetric arms, left and right sides.

The remaining two long arms, install at either post in the rear positions.

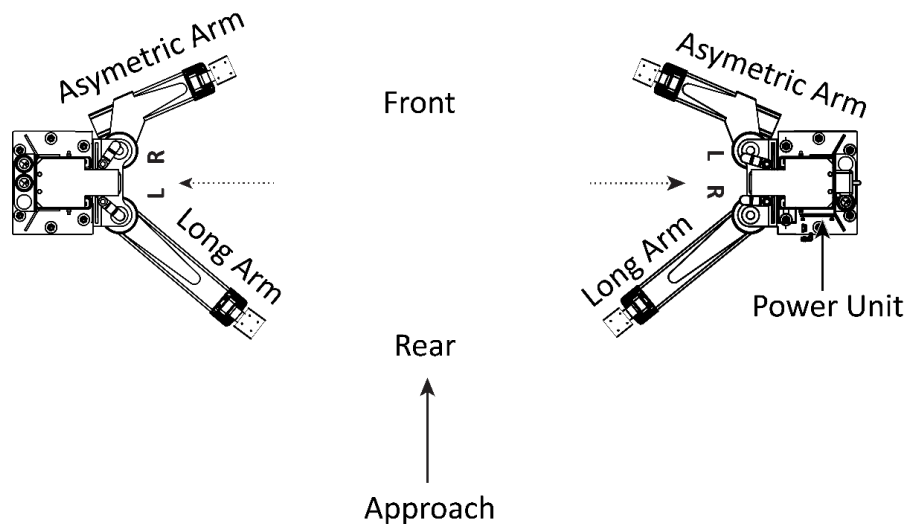

Arm Installation, Component Identification:

| Item | Description | Part Number | Qty. |
|----------|---|-------------|------|
| A | Asymmetrical Arm, Triple Telescoping, Left | 5216197 | 1 |
| | Asymmetrical Arm, Triple Telescoping, Right | 5216198 | 1 |
| B | Long Arm, Triple Telescoping | 5216203 | 2 |
| C | Arm Lock Guide Rod | 5602030 | 4 |
| D | Arm Lock Pin | 5601910 | 4 |
| E | Full Circle Gear Stop | 5701954 | 4 |
| F | Set Screw M6 x 1 x 12 | 5530551 | 12 |
| G | Clevis Pin | 5505086 | 4 |

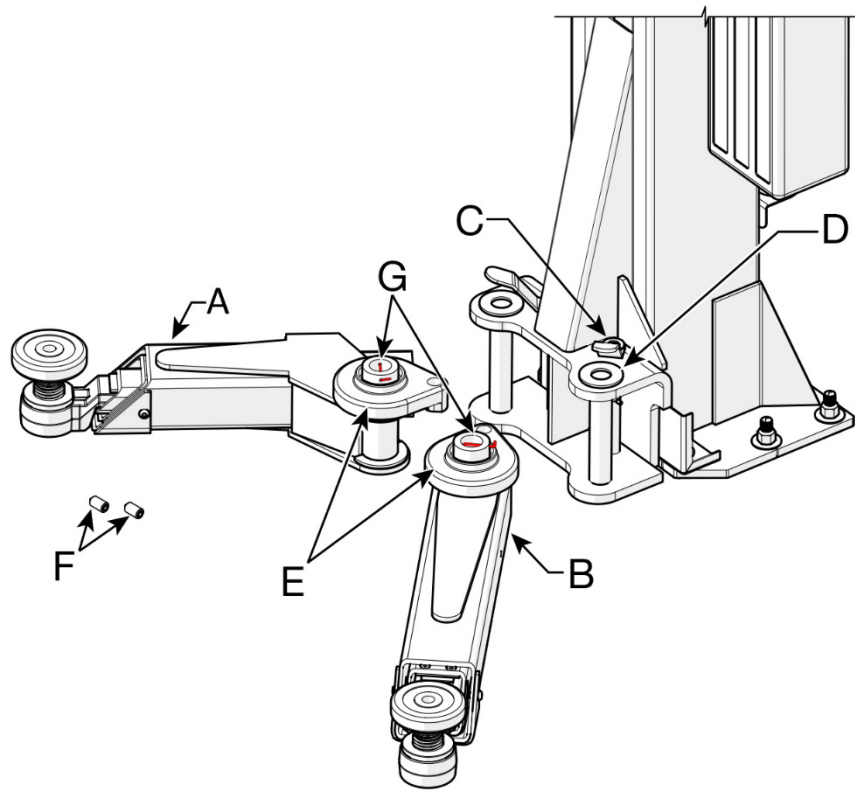

To install the lift arms:

- Using a forklift or shop crane, raise the desired lift head to the first locking position.

⚠ WARNING Verify the lift head is engaged on a safety lock and the downward motion of the lift head is blocked by a jackstand or equivalent.

⚠ CAUTION The lift head and lift arms are heavy. Exercise caution when raising the lift head to the first locking position. Use a forklift or shop crane. Lift heavy components carefully to avoid injury.

2. Locate and retrieve the correct asymmetrical lift arm (A) and the correct long lift arm (B). See page 5 for correct orientation of lift arms.

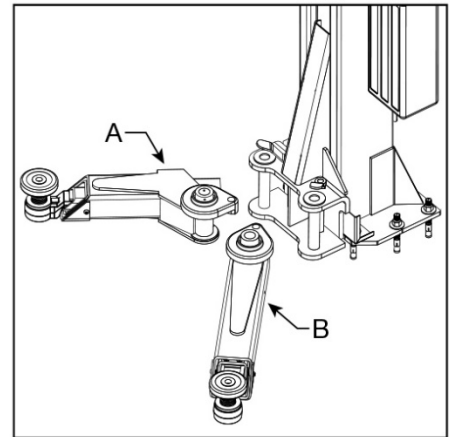

3. Remove the arm lock guide rod (C) by pulling up.

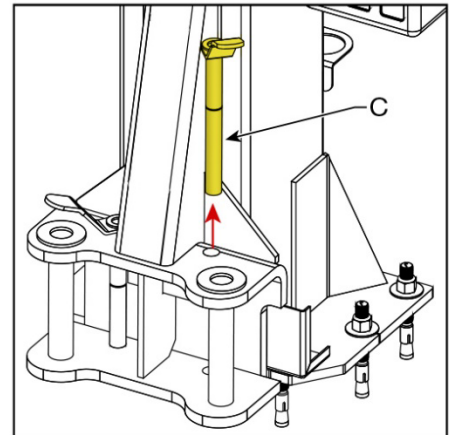

4. Remove the arm lock pin (D) by pulling it up.

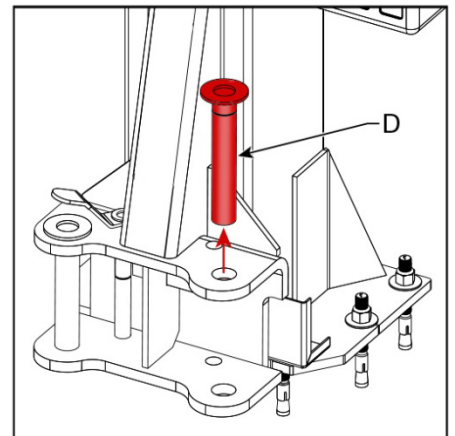

5. Insert the long lift arm (B) into the lift head.

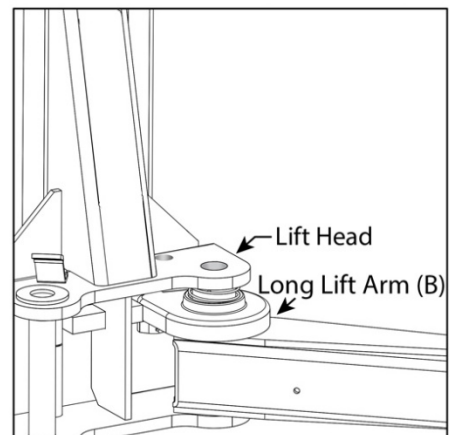

- Remove the Clevis Pin (G) securing the Compression Spring in the Stop Gear (E). The Compression Spring will force the Stop Gear to engage the Restraint Gear mounted on the top of the Long Arm.

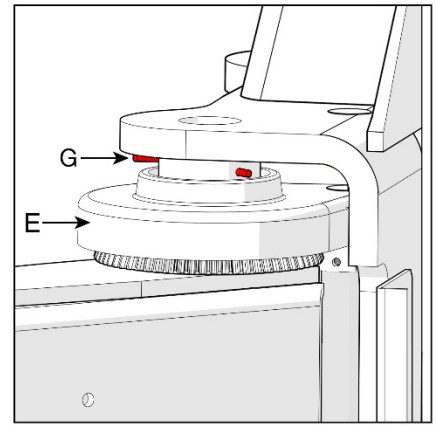

- Install the Arm Lock Pin (D) by inserting it into the Lift Head and all the way through the Lift Arm.

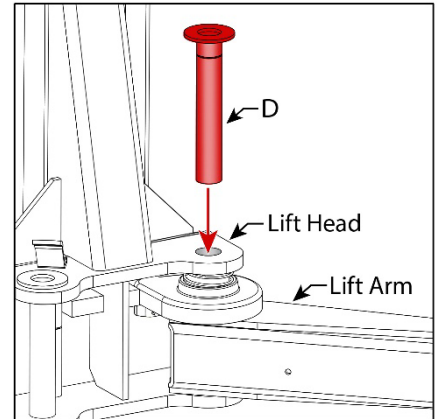

- Return the Arm Lock Guide Rod (C) to the Lift Head, ensuring that it passes completely through the Stop Gear (E) mounted on the Long Arm (B).

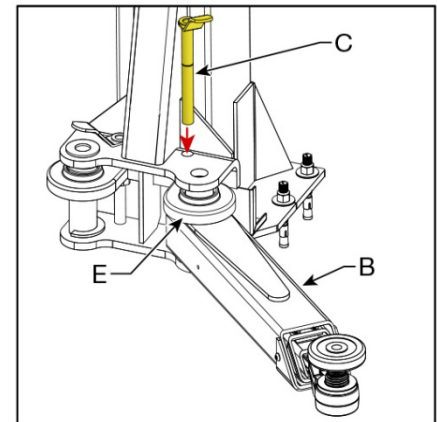

- Apply removable thread lock compound to two Set Screws (F).

- Secure the Stop Gear (E) to the Arm Lock Guide Rod (C) using the two set screws (F)- M6x1x12. Two set screws are **required**. Install on the side of the stop gear as shown below.

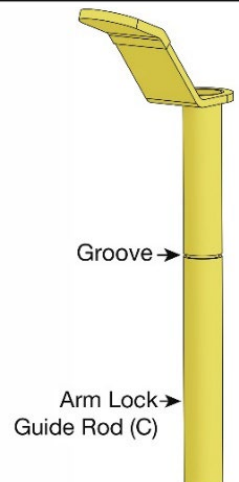
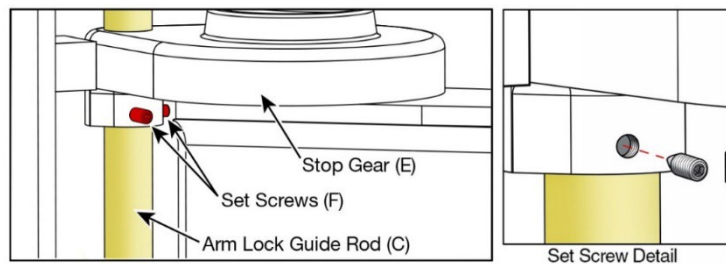

IMPORTANT! The set screw (F) must thread into the groove in the arm lock guide rod (C). See illustration to the right.

11. Prepare one set screw (F) with removable thread locker.
12. Secure the Arm Lock Pin (D) using the one (1) Set Screw (F) M6x1x12 - threaded into the Arm Mount Tube (H). Only one set screw is required. Choose the side that is easiest to access.

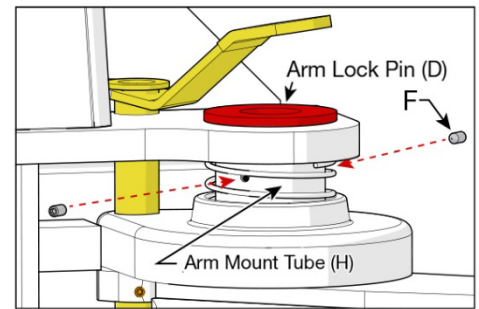

13. Repeat Steps 1 –5 for the remaining three Lift Arm assemblies.

14. Ensure the arm restraint gear meshes with the gear stops as described in the warning below.

WARNING Verify that the arm restraint gears and the gear stops are meshing and stay in place when up to 150 pounds of lateral force is applied—before putting the Lift into normal operation.

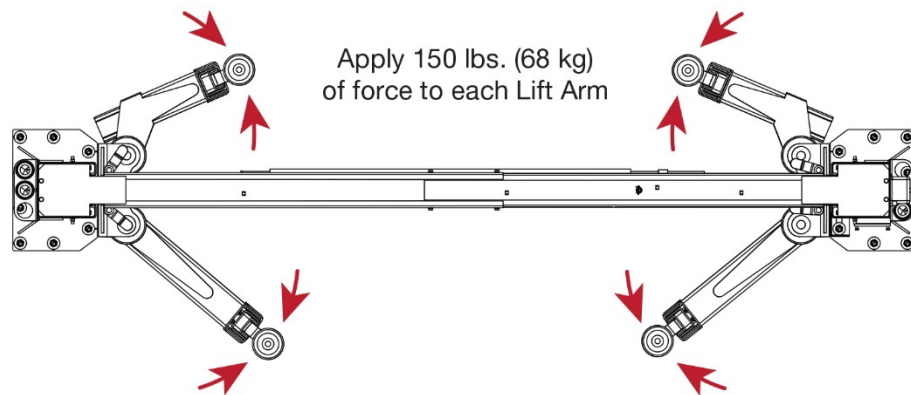

DANGER Each lift arm assembly **must** be inspected and adjusted as required before each use. Do **not** operate the Lift if any of the four lift arm restraint systems are not functioning correctly. Replace any damaged components with approved replacement parts only.

Leveling

Before operating the Lift, make sure the posts are parallel and properly aligned. Most floors have a slight slope, making the posts plumb to the floor can cause the lift pads to be uneven, which is unsafe. The posts must remain parallel, and the pads should be as level with each other as possible.

- **Lift Posts:** Measure the distance between the posts at one foot above the floor, with the lift arms moved out of the way, and again near the top of the posts. The two measurements (A and B in the figure below) must be equal.

If the posts are not parallel, install shims as required to make them parallel. Continue shimming until the contact pads are level with each other. **Do NOT exceed** 0.5 in. (13 mm) of shim. The posts do not need to be perfectly plumb to the floor as long as they remain parallel.

Confirm parallel alignment:

1. Lower the lift to the floor and spread the front arms so they point directly at each other.
2. Measure from the center of the left front pad to the center of the right front pad.
3. Raise the lift to full height and measure again. The pad-to-pad distance must remain the same. If it changes, shim the posts as required until the posts are parallel. If the floor has a severe slope or the lift requires more than 0.5 in. (13 mm) of stacked shims, contact BendPak for leveling guidance.

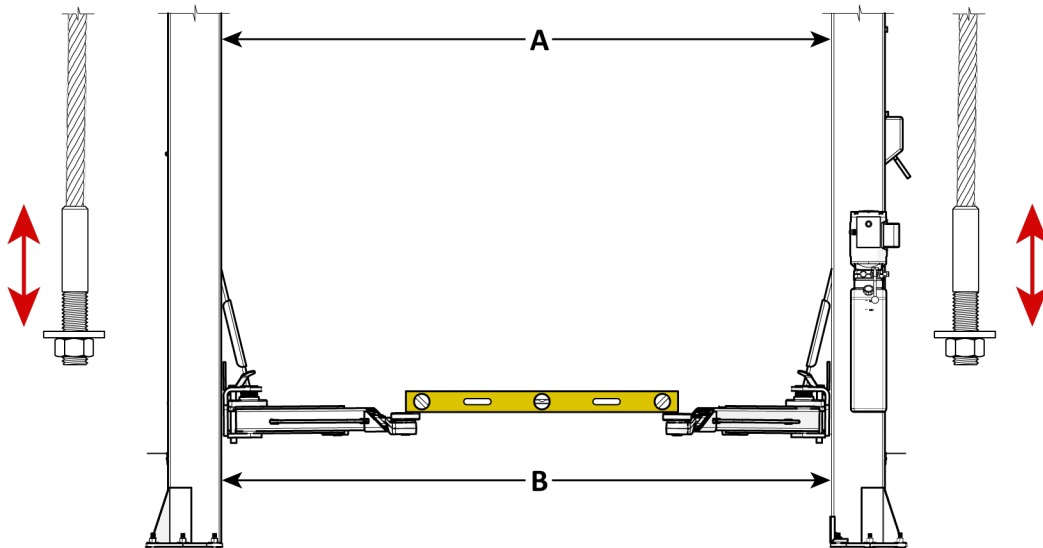

CAUTION

Posts that are not parallel or pads that are not level create a safety hazard. Vehicles placed on the Lift will be less secure and could fall, causing injury or damage to the vehicle, the Lift, or nearby personnel.

NOTICE

A minor lean in a column is acceptable when needed to achieve even pads. BendPak structural components have safety factors exceeding 400%, so minor increases in moment loading do not compromise structural integrity.

- **Lift Arms:** After the posts are parallel, verify that the contact pads are within .25 in. (6 mm) of each other. Raise the lift to the first locking position and place a straightedge or level across the pads to confirm they are even.

-
- **Adjust the equalizing cables.** With the Lift resting on the safety locks, remove the polyethylene covers from each lift head to access the equalizing cable adjustments. If a cable has slack, remove the polyethylene cover on the lift head and slowly tighten the hex nut on the bottom of the threaded cable end until the slack is removed. Do not tighten the nut enough to lift the lift head off the safety lock. Return the polyethylene cover to the lift head after adjusting.

Leveling Summary

- a. Keep the columns parallel: the distance between the columns should remain consistent at both the base and the top.
- b. Prioritize pad height: Shim the columns as needed so the lifting pads are level from left to right.
- c. Follow the manual spacing: if the columns are installed at the correct spacing as per the manual, they will remain parallel after shimming.
- d. Do not rely on visual plumb alone: a column may appear slightly out of plumb, but that is acceptable if the pads are level *and the columns remain parallel*.
- e. Shim for precision: adjust shims until the arm pads are *within 1/4 in. (6.35mm)* of each other. This distance can make a significant difference when positioning low-profile vehicles.

IMPORTANT **After shimming is complete, all Lift anchors must be torqued to 85 to 95 ft-lb.**

NOTICE The equalizing cables will stretch during use and must be checked weekly for equal tension. Unequal tension will cause uneven lifting. Adjust the cables so they have equal tension when the Lift is resting on the safety locks.

Contact the Electrician

The following installation tasks require an Electrician.

⚠ DANGER All wiring **must** be performed by a licensed Electrician in accordance with all applicable national and local electrical codes.

The Electrician is required to:

- **Connect to the facility power.** The power unit is delivered with a pigtail for wiring to a power source. The Electrician is to connect a power cord with plug to the electrical box on the Lift (for connection to a power outlet) or have them wire it directly into the electrical system at the Lift location.
- **Connect the limit switch to the power unit.** The limit switch (above the Safety Shutoff Bar) must be wired to the power unit. The necessary wiring is included.
- **Install a power disconnect switch.** Ensures you can quickly and completely interrupt electrical power to the Lift in the event of an electrical circuit fault, emergency, or when equipment is undergoing service or maintenance. The Electrician must install it within sight and easy reach of the Lift operator. Refer to **Installing a Power Disconnect Switch** for more information.
- **Install a Thermal Disconnect Switch**, if required by local electrical code. Refer to **Installing a Thermal Disconnect Switch** for more information.

The Electrician is responsible for providing:

- Wire and appropriate protection between the Lift and the electrical service entrance.
- An appropriate circuit breaker.
- A power disconnect switch.
- A thermal disconnect switch, if required by local electrical code.

Additional information is supplied in the following sections describing these tasks.

Electrical Information

⚠ DANGER All wiring **must** be performed by a licensed Electrician in accordance with all applicable national and local electrical codes. Do not perform any maintenance until main electrical power has been disconnected from the Lift and cannot be re-energized until all procedures are complete.

Important electrical information:

- Improper electrical installation can damage the power unit motor, which is not covered by the warranty.
- The Lift uses electrical energy; if your organization has Lockout/Tagout policies, make sure to implement them after connecting to a power source.
- Use a separate circuit breaker for each power unit.
- Protect each circuit with a time delay fuse or circuit breaker:
 - 208 to 230 VAC, **single phase** circuit, protected by an appropriate time delay fuse or circuit breaker for the power unit delivered with the Lift.

Wiring the Overhead Limit Switch

This section describes how to wire the limit switch; *installing* the limit switch was described in [Installing the Limit Switch](#).

The Lift is delivered with a limit switch:

- **Single Phase power units require** one limit switch, which must be wired between incoming power and the Electrical Box on the power unit on one of the two “hot” wires.
- **Three-Phase power units require** two limit switches, which must be wired between incoming power and the junction box on the power unit on two of the three hot legs. Both limit switches delivered are identical. If wiring *two* limit switches, they **must** be wired on two **different** hot legs. **For Three-Phase Installations see [Three-Phase Limit Switches Installation](#).**

⚠ WARNING Keep all wiring flat and secured with the cable clips provided in the Lift. Verify all wiring and hydraulic hoses are clear of all moving parts and pinch points.

Refer to the diagrams in [Wiring Diagrams](#) for detailed limit switch wiring information.

The following procedure assumes the limit switch is already in place. If it is not, refer to [Installing the Limit Switch](#) to install it.

To wire a limit switch on the Lift: *Refer to the figure on the next page.*

1. Verify the limit switch mounting on the overhead assembly is on the same side as the power unit. If not, the overhead assembly must be removed and rotated to place the limit switch on the power unit side.
2. Locate the 14/2 limit switch cable supplied with the Lift.
3. **On the overhead assembly**, connect one end of the limit switch cable to the limit switch (or two limit switches, for a 3-Phase power unit). Refer to [Wiring Diagrams](#) for wiring information.
4. Route the cable from the limit switch through the clips on the overhead assembly over the Double Threaded Rod to the power side post, down the inside of the power side post, through the clips, out the Grommet in the Post below the safety lock Release, and over to the Electrical Box on the power unit. All wiring is to be straight with no slack and secured in the wiring clips. Refer to the figure on the next page.
5. Once the cable is routed from the limit switch to the power unit, secure the cable in the cable Clips on the overhead assembly and inside the power side post. This will secure the cable and keep it clear of any moving Lift components.

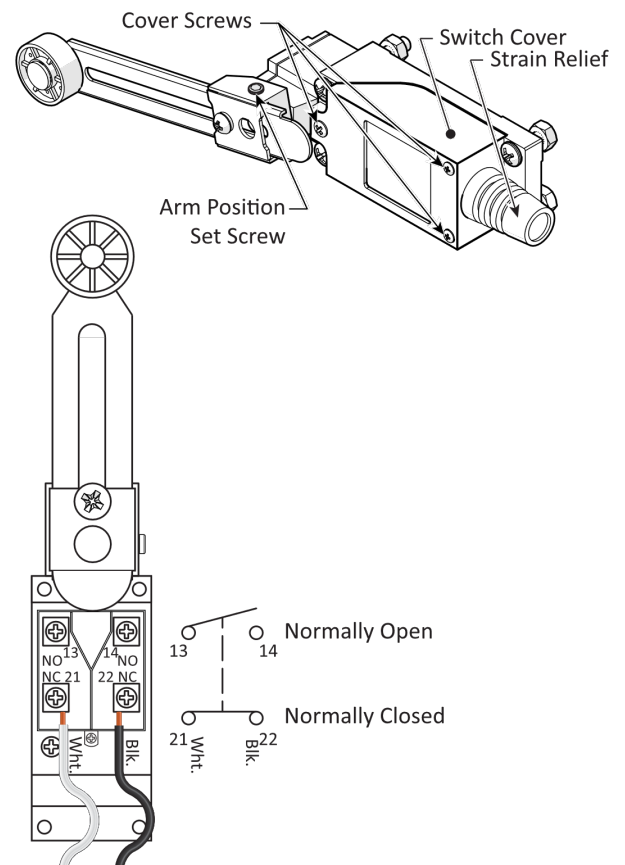

6. **On the power unit**, open the junction box and connect the limit switch cable as per the instructions found in **Connecting the Power Unit**.

Important! Verify all cables and hoses are tight and flat against the inside of the Lift Posts and routed to avoid interfering with moving components inside the Lift Posts.

Connecting the Power Unit

The power unit and the limit switch must be connected to an appropriate power source.

- ⚠ DANGER** All wiring **must** be accomplished by a licensed Electrician. Do not perform any maintenance or installation on the Lift without first verifying that main electrical power has been disconnected from the Lift and cannot be re-energized until all procedures are complete. If your organization has Lockout/Tagout policies, make sure to implement them after connecting to a power source.
- ⚠ DANGER** Make clear to the Electrician that all electrical work **must** conform to applicable local, state, and federal electrical codes.
- ⚠ DANGER** **Risk of explosion:** This equipment has internal arcing or parts that may spark and should not be exposed to flammable vapors. The power unit's motor should not be located in a recessed area or below floor level. Mount the motor at least 18 in. (457 mm) above the floor. Never expose the motor to rain or other damp environments; damage to the motor caused by water is not covered by the warranty.

The 12APX Series Lift is available with the following power unit: **208-230VAC, 60 Hz, 1 Phase**

- **5 HP, 19.5 FLA (5585685)**
- **5 HP, 18 FLA (5585037)**

NOTICE 110 VAC power units are currently **not** available for 12APX Series Lifts.

To Install a Single-Phase Power Unit see **Single-Phase Power Unit Wiring**

To install Three-Phase Power units see **Three-Phase Power Unit Wiring**.

The illustration of the right is a front view of a typical power unit. The specific power unit delivered may vary.

Note: The **Up** Switch shown in the illustration may be in a different location on the unit or could be a pushbutton instead of a rotary switch, depending on the power unit delivered.

NOTICE Wiring information is either on the outside of the power unit under the Electrical Junction Box or inside the cover of the Electrical Junction Box. Have the Electrician use that wiring information to wire the power unit to the power source.

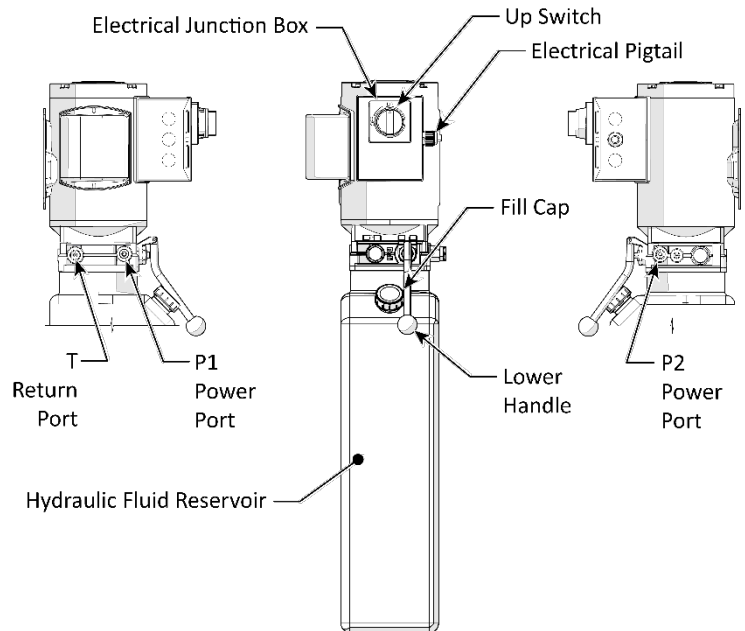



To prepare the Power Unit:

1. Have the Electrician locate the Pigtail exiting of the electrical junction box on the power unit.
2. Open the electrical junction box, remove the pigtail, and then either:
 - Wire the power unit directly into the facility's electrical system and typically protected by a 25 Amp circuit breaker or time delayed fuse.
 - Wire a power cord (with appropriate plug) *inside the electrical junction box* to the wiring that was connected to the pigtail.
3. Wire the limit switch(es) into the incoming power. Refer to [Wiring Diagrams](#) for wiring information.
4. Fill the hydraulic fluid reservoir with approved hydraulic fluid.

The reservoir holds **≈3.5 gallons** of hydraulic fluid, depending on which power unit you have.

Approved hydraulic fluids are any general-purpose ISO-32, ISO-46, or ISO-68 hydraulic oil or approved automatic transmission fluids such as Dexron VI, Mercon V, Mercon LV, Shell Tellus S4 / S3 / S2, or any synthetic multi-vehicle automatic transmission fluid.

 **WARNING** Do not run the power unit without hydraulic fluid; you will damage it.

 **WARNING** Running high electrical current that exceeds the motor's full load amps (FLA) rating may result in permanent damage to the motor. BendPak strongly recommends you **do not** exceed the rated duty cycle of the Lift motor.

Installing a Power Disconnect Switch

⚠ WARNING A power disconnect switch is **not** provided with this equipment.

A power disconnect switch is a requirement for the National Electrical Code (NEC). They are designed to allow the operator to interrupt the main electrical power in the event of an emergency or circuit fault, or when the equipment is undergoing service or maintenance.

Make sure to install a power disconnect switch that is properly rated for the incoming power source.

The power disconnect switch must be readily accessible and installed so that it is within easy reach of the operator or in their line of sight. The power disconnect switch must be clearly marked to indicate its purpose.

The figure to the right details a power disconnect switch located between the Lift's power source and its power unit. A quick flip of the switch immediately cuts power to the Lift.

The Electrician may want to move the power disconnect switch location up to accommodate local electrical code or conditions.

⚠ DANGER Installing a power disconnect switch **must** be accomplished by a licensed Electrician in accordance with local and national electrical codes.

Have the Electrician select a **UL-listed** power disconnect switch.

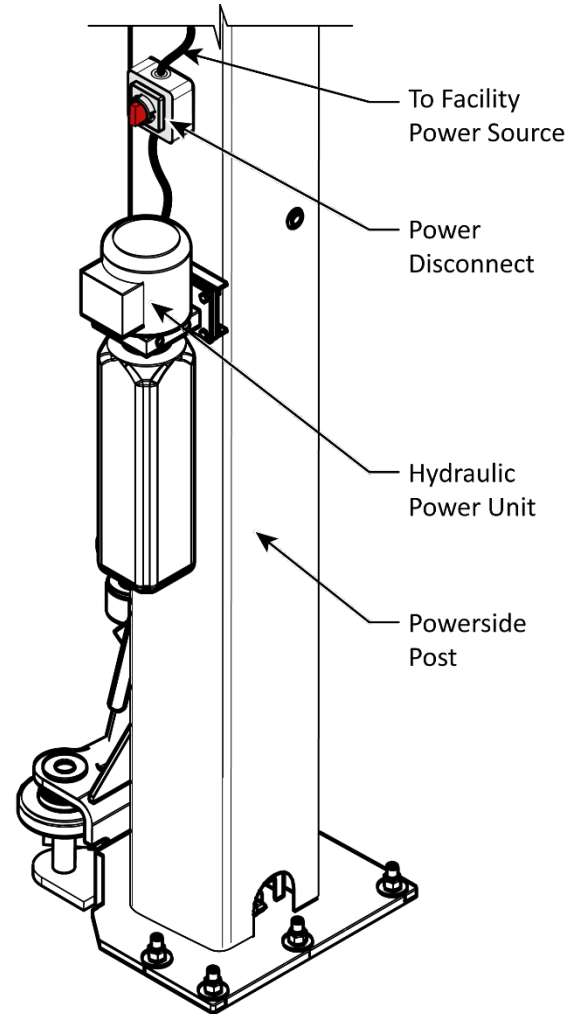

Installing a Thermal Disconnect Switch

The power unit supplied with this Lift **does not** include thermal overload protection. Under NEC 430, UL 201, and CSA C22.2 No. 68 intermittent duty motors are not required to include thermal protection. Local electrical codes may vary, and other requirements may exist that the installing electrician will address, if required.

⚠ DANGER If local Electrical codes require the installation of a Thermal Disconnect, the disconnecting device and the installation **must** be provided by a licensed Electrician in accordance with local electrical codes. Do not perform **any** maintenance or installation on the Lift without first verifying that main electrical power has been disconnected from the Lift and **cannot** be re-energized until all procedures are complete.

Lubricating the Lift

⚠ WARNING BendPak does not supply hydraulic fluid or lubricants with this Lift. **Always** refer to the Safety Data Sheet (SDS) for safe handling and disposal information. SDS are available from the hydraulic fluid or lubricant's supplier or manufacturer.

Lubricate the following with a white lithium grease or similar:

- All cable sheaves and cable sheave pins
- The four inside corners of both Posts
- Safety sheaves
- All lift arm pivot points

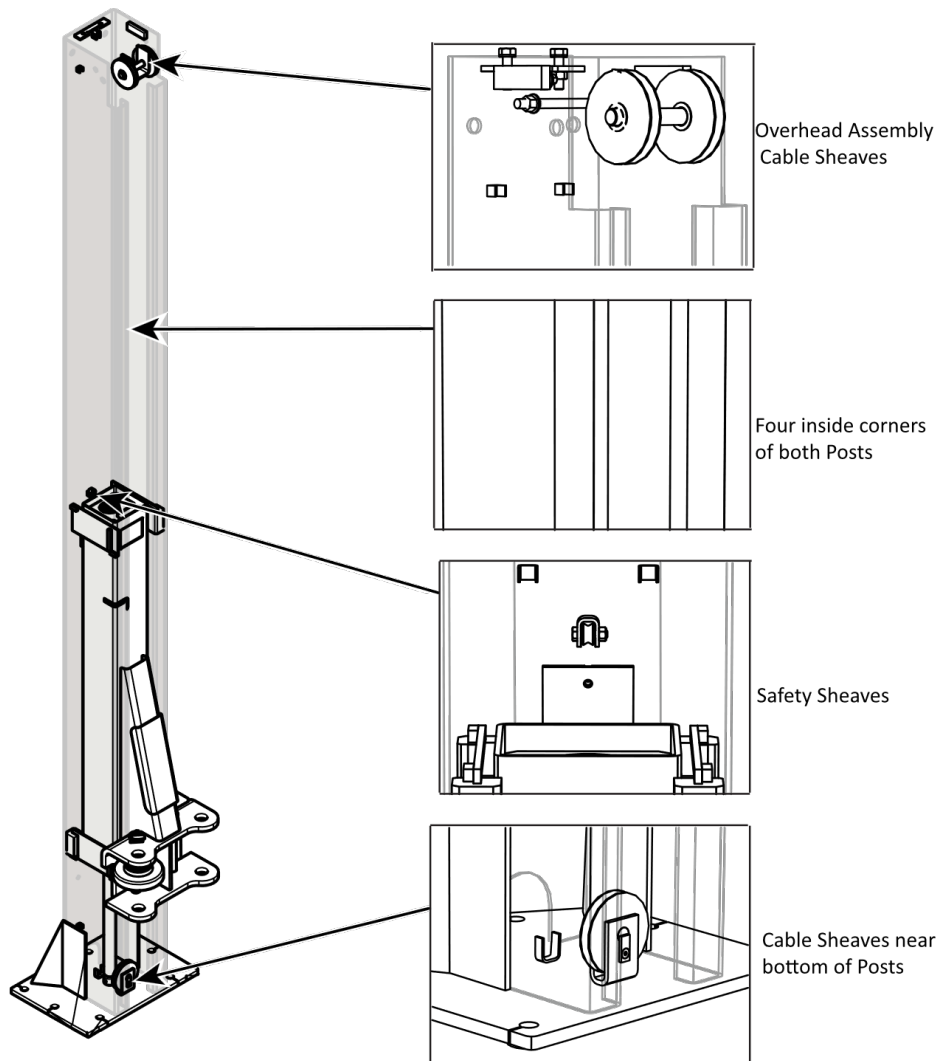

Some Components Removed for Clarity

Review Final Checklist Before Operation

Make sure these things have been done before putting the Lift into normal operation:

- 1. Review the **Installation Checklist** and verify all steps have been performed.
- 2. Make sure the power unit is supplied with electrical power.
- 3. Check the hydraulic fluid reservoir; it must be full of approved hydraulic fluid or automatic transmission fluid. **You can damage the motor by running it without enough fluid.**
- 4. Check the hydraulic system for leaks. Verify all hydraulic hose connections, hydraulic fittings, and auxiliary port plugs on the Lift and power unit are tight.
- 5. Make sure both posts are properly plumbed, shimmed, and stable.
- 6. Check to see that all anchor bolts are correctly torqued.
- 7. Lubricate all cable sheaves and the inside of the posts where the slide blocks move.
- 8. Verify both double threaded rods are in place and tightened near the top of both Posts.
- 9. Verify all cables are properly positioned in their sheaves.
- 10. Verify sure all cable sheave retaining pins and/or clips are secure.
- 11. Verify both safety assemblies are connected and working normally.
- 12. Verify the cylinder clamps are secured in place above the hydraulic cylinders.
- 13. Verify that all safety locks are clear and free.
- 14. Verify an operational test has been successfully performed.

Perform an Operational Test

Before putting the 12APX Lift into normal operation, we recommend raising and lowering it several times with a typical vehicle on the Lift. This will help the operator get a feel for how to operate the controls and help remove any residual air out of the hydraulic system (sometimes called “bleeding” the system).

⚠ DANGER Automotive Lifts are dangerous tools when used by inexperienced or impaired technicians. Remember that lifting a vehicle is a serious endeavor with life-threatening risks if lifting precautions are ignored.

During the operational test, check for proper installation and operation. Do not raise any additional vehicles until a thorough operational test has been completed with a typical vehicle.

⚠ WARNING Never raise a vehicle whose weight exceeds the rated capacity of the Lift. Do not leave the controls until the Lift is engaged on its safety locks. Only trained personnel should raise or lower the Lift.

To perform an Operational Test:

1. Make sure all the areas in **Review Final Checklist before Operation** have been covered before proceeding.
2. Follow the instructions in **Raising a Vehicle** and **Lowering a Vehicle** to safely raise and lower a vehicle on the Lift.

⚠ DANGER Follow the instructions carefully when it comes to contacting the manufacturer’s recommended lifting points on the underside of the vehicle. If you do not, the

vehicle could become unstable and fall, which could damage the vehicle, damage the Lift, and injure or even kill anyone under the vehicle.

3. Adjust the lift arms under the vehicle so the adapters are directly under the Lifting Points for the vehicle you are raising. If necessary, use Auxiliary adapters (accessories available separately) for extra height.
4. Press the **Up** button to raise the Lift until **just before** the adapters contact the Lifting Points.
5. Check the Arm Restraint Gears on all four Lift Arm Assemblies to make sure they are engaged. If they are not engaged, move the lift arms back and forth until they engage.
6. Raise the Lift until the tires of the vehicle are a few inches above the ground.
7. Verify all four adapters are making solid contact with all Lifting Points.

If any of the adapters are **not** making solid contact with the Lifting Points, carefully lower the Lift and start over again; the adapters **must** make solid contact with all Lifting Points.

8. Raise the vehicle approximately three feet off the ground, then release **Up**, then *press and hold* the safety lock release handle and the lowering handle to lower the Lift back down.

NOTICE

Residual air in the hydraulic system can cause the Lift to shake, move erratically, or squeak; this is normal when you first start using the Lift. The noises will reduce then cease, as the hydraulic system self-bleeds air from the system.

9. Wait for one to five minutes. This allows air flushed into the reservoir to escape from the hydraulic fluid.

 **WARNING** The power unit is not a constant duty motor; **do not run continuously**.

10. Repeat the process, this time raising the Lift, engaging it on a safety lock position, taking it off the safety lock position, and then lowering it back down to the ground.
11. If the Lift is working without shaking, moving erratically, or squeaking, there is no need to repeat the procedure. If the Lift is shaking, moving erratically, or squeaking, repeat the procedure one more time. If you continue to have issues, refer to **Troubleshooting** for assistance.
12. When the Lift is on the ground and the vehicle is on all four tires, move the four lift arms to their full drive-through positions, then drive the vehicle out.
13. With no vehicle on the lift arms, press and hold the **Up** button on the power unit.
14. Have another person push up the safety shutoff bar with a broom or long pole until it triggers the limit switch.

If the lift arms do not stop rising when the limit switch is triggered, this indicates the limit switch is either not correctly installed mechanically or not wired correctly. Return to the sections in this manual where installation and wiring of the limit switch is described to identify and correct the issue.

 **CAUTION** Do not put the Lift into normal operation until you have confirmed that triggering the limit switch stops the lift arms from rising.

Leave the Manual with the Owner/Operator

Leave the *Installation and Operation Manual* with the owner/operator so that it is available to everyone who is going to use the Lift.



Operation

This section describes how to operate your BendPak 12APX Series Lift.

 **DANGER** Automotive Lifts are dangerous tools when used by inexperienced or impaired technicians. Lifting a vehicle is a serious endeavor with life-threatening risks if mandatory lifting precautions are ignored.

Lift Operation Safety Rules

 **DANGER** Your safety depends on reading, understanding, and implementing these Safety Rules. Do not skip over them; read them carefully and follow them!

Do the following **before** you raise or lower a vehicle on your Lift:

Check the Lift. A complete inspection of the Lift is required before using it. Check the hydraulic system for loose connections including hydraulic fittings, hydraulic hoses, and any Auxiliary Port Plugs. Check the Lift for any missing, heavily worn, or damaged parts. Do not operate the Lift if you find any issues; instead, take it out of service, contact your dealer, email support@bendpak.com, or call **(800) 253-2363**, follow the prompts to reach support.

- **Check the area.** Keep the area around the Lift clean and free of obstructions; anything that could cause a problem for the Lift. Do not forget to check **above** the Lift. If you find an obstruction, move it out of the way. Do not allow any people or animals within 30 feet of the Lift while it is in motion.
- **Check the operators.** Make sure that everyone who is going to operate the Lift has been trained in its use, has read the labels on the unit, has thoroughly read the manual and understands how this equipment works. Only the operator should be within 30 feet of the Lift when it is in motion. Do not allow children to operate the Lift. Do not allow anyone under the influence of drugs or alcohol to operate the Lift.
- **Check for safety.** Make sure everyone who is going to be walking near the Lift is aware of its presence and takes appropriate safety measures. Only put vehicles on the lift arms. **When raising a vehicle on the Lift, do not leave it until it is positioned on safety locks.** When lowering the Lift, do not leave it until it is on the ground.
- **Check the vehicle.** Never exceed the Lift's weight rating. Do not allow people inside a vehicle you are going to raise. Make sure the vehicle is not overbalanced on either end. Make sure you know the manufacturer's recommended Lifting Points for the vehicle. Never raise just one side, one corner, or one end of a vehicle.

 **WARNING** Always use care when you are around your Lift. When it is in a lowered position, be careful not to trip over it. When it is raised, be careful not to hit your head on the lift arms or the vehicle. **When you are raising or lowering a vehicle, keep all personnel and objects at least 30 ft. (9.1 m) away from the Lift.**

About Lifting Points, Adapters, and Auxiliary Adapters

A crucial point to keep in mind when using a frame-engaging Lift is that the raised vehicle must be balanced on the four lift arms. If the vehicle is not balanced, it is more likely to become unstable and slide off the Lift, possibly damaging the Lift, the vehicle, and anything under the Lift, including injuring people.

⚠ WARNING You **must** use all four lift arms when raising a vehicle. Never use just one, two, or three lift arms to raise a vehicle. The vehicle will be unstable and could slip off the Lift, possibly damaging the Lift, damaging the vehicle, and injuring anyone under it.

To balance a vehicle on a frame-engaging Lift, you need to have the adapters (also called Pads) contact the vehicle on the manufacturer's recommended Lifting Points. When you raise a vehicle by its Lifting Points, the vehicle is balanced.

NOTICE The manufacturer's recommended Lifting Points do not take into consideration any major changes that might have been made to the vehicle. If the motor is removed, for instance, or there is heavy weight in the trunk, the vehicle's Lifting Points will not be the best balancing points.

Some vehicles have indicators on the underside that identify the Lifting Points; many do not.

Your best approach is to find the vehicle in the guide provided with your Lift. *Vehicle Lifting Points for Frame Engaging Lifts* or contact the manufacturer of the vehicle. This guide also includes a page of safe lifting suggestions, which everyone who uses the Lift should read.

Lifting it Right: A Safety Manual from the Automotive Lift Institute, also provided with your Lift, includes a variety of information about Lifts and how to use them safely.

⚠ DANGER **Never** place any contact pads on non-approved, non-load holding sill covers or side skirts!

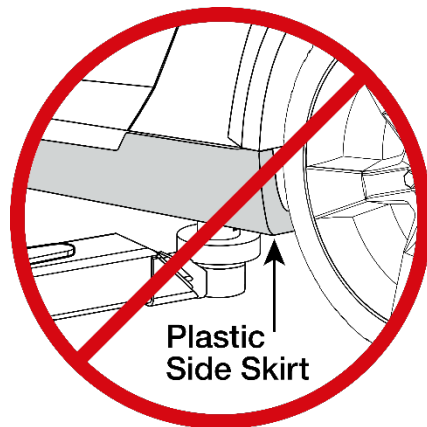

Standard Accessories

Included with the 12APX Lift are **Four Medium Auxiliary Adapters - 2.50 in. (63 mm)** (5215758) and **Four Tall auxiliary Adapters - 5.00 in. (125 mm)** (5215759). Additional sets are offered to allow you to position the height of the auxiliary adapters to make better contact with vehicles.

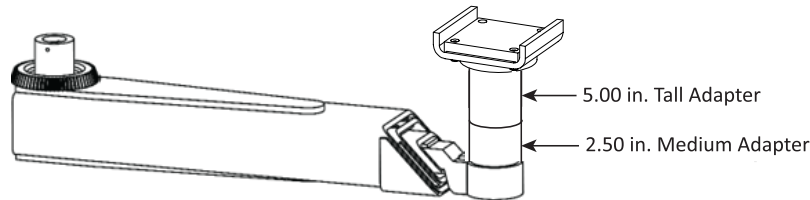

The 12APX Lift also includes **Frame Cradle Adapters** — Required for use on Perimeter Frames when lifting trucks, vans or other frame vehicles that require additional stability. Set of 4 (5215761). Additional sets are also offered.

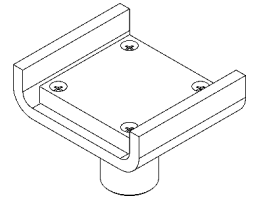

Optional Accessories

(Not included with the 12APX)

⚠ WARNING Auxiliary adapters may be stacked, but only up to 9 in. If you stack Auxiliary adapters above 9 in., the vehicle could become unstable and slip off the Lift, possibly damaging the Lift, damaging the vehicle, and injuring anyone under it.

- **SUV and Van Adapters** — Recommended for Trucks, SUVs, and Vans requiring additional lifting height.

190 mm (5210495) Set of 2

240 mm (5210498) Set of 2

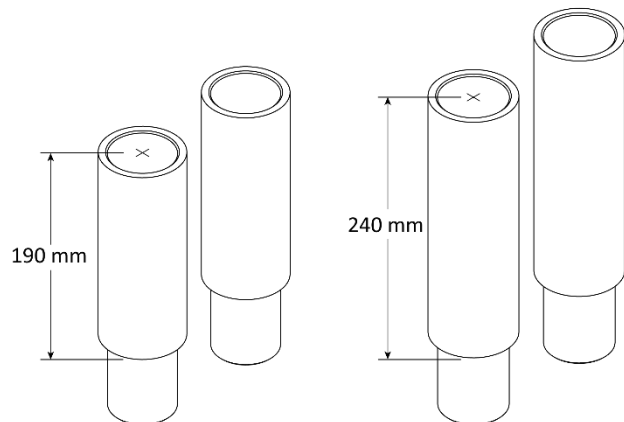

Round Adjustable Screw Pads — Round double-telescoping, set of 4

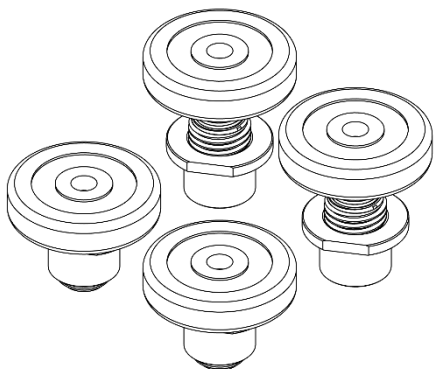

⚠ WARNING Use the correct adapters. Do not attempt to lift trucks or other frame type vehicles with standard rubber contact pads

Quick-Fit Slotted Pinch-Weld Pucks or Pads — Always use slotted Pinch-Weld Pucks (5210263) or slotted Pinch-Weld Pads (5210254) when lifting vehicles on manufacturer approved pinch-weld jacking points. These convenient tear-resistant urethane adapters simply fit over the round contact pads.

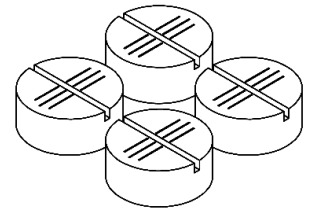
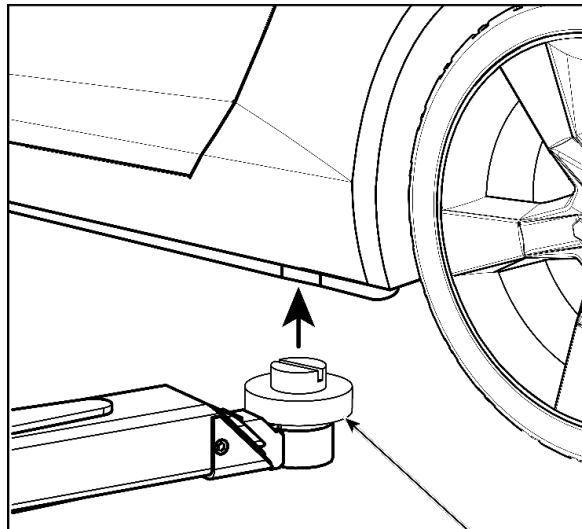

5210254 Set of 4 Slotted Pads

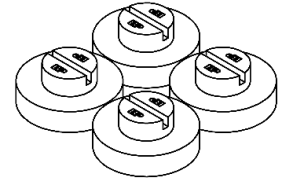

5210263 Set of 4 Slotted Pucks

✓ Always use slotted Pads or Pucks when lifting Vehicles on OEM-approved Pinch Weld Jacking Points.

- **Wide Frame and Super Wide Frame Cradle Adapters** — Recommended for use when lifting heavy-duty wide frame vehicles.
- **Wide Frame** version fits vehicle frames up to 5.25 in. (133 mm) (5215848) wide, Set of 2.
- **Super Wide Frame** version fits vehicle frames up to 6.5 in. (168 mm) (5210253) wide, set of 2.

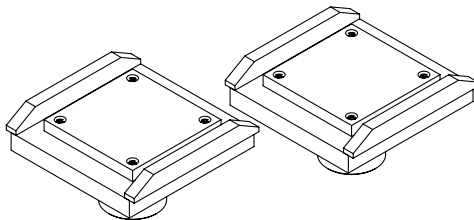

Wide Frame Cradle Adapter

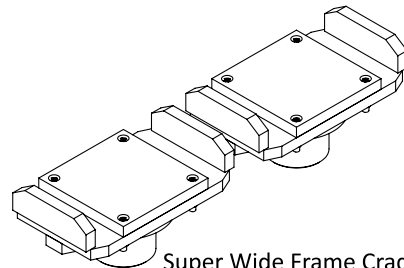

Super Wide Frame Cradle Adapter

- **Cradle Lift Pad** — Wide Polyurethane Pad, set of 4 pads (5210231).

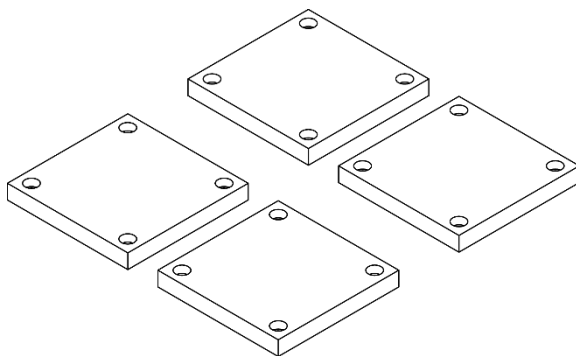

Steel Lift Pads — Recommended for additional stability on all vehicles. The flanged edges grip the chassis for an extra-secure hold, set of 4 lift pads. (5215763)

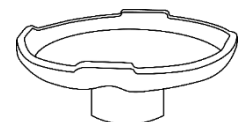

Contact BendPak for accessories and replacement parts information at **(800) 253-2363**, then follow the prompts; please have the model and serial number of your Lift available. Visit bendpak.com for additional adapters and auxiliary adapters (also called height adapters or extenders).

Raising a Vehicle

This section describes how to raise a vehicle on your 12APX Series Two-Post Lift.

⚠ WARNING Never raise a vehicle whose weight exceeds the rated capacity of the Lift. Do not leave the controls until the Lift is engaged on a safety lock position or fully lowered. Only trained personnel should raise and lower the Lift.

⚠ WARNING Always stay within the safe operator area when using the Lift. Refer to the figure below. The safe operator area will keep the operator clear of crushing, shear and pinch points while providing an unobstructed line of sight to the vehicle and access to the Lift controls. Personnel near the Lift but outside of the safe operator area should be moved clear of the lift by a minimum of 30 ft. (9 m).

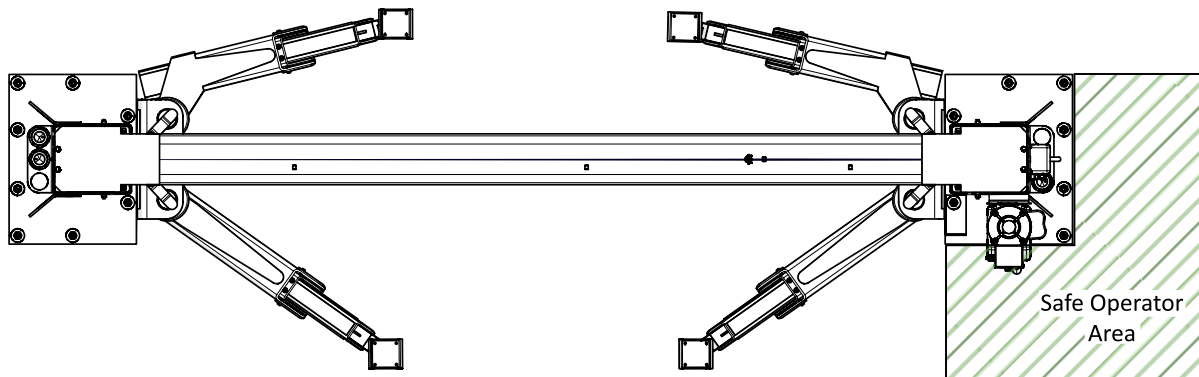

To raise a vehicle:

1. Verify all four lift arms are on the ground in their full drive-through positions and all personnel are clear of the service bay.
2. Check under the vehicle you are going to raise, check for the type of vehicle frame, and then put the most appropriate adapters on the lift arms.

If you are lifting a sedan or a vehicle with a unibody construction, a screw lift pad is generally the best choice. If you are lifting an SUV, truck, or other vehicle with a frame construction, a frame cradle pad is often the best choice.

⚠ WARNING Always use the adapter type best suited for the vehicle you are raising. If you use the wrong adapter type, the vehicle could become unstable.

3. Drive the vehicle into the service bay.

⚠ CAUTION When driving a vehicle into position, keep to the middle area between the Posts. If you hit a Lift Arm or any other portion of the Lift, you could damage the vehicle and/or the Lift.

4. When you are satisfied with the location of the vehicle, put it in park, put on the parking brake, and turn off the motor.

If the vehicle is a manual transmission, put it into first gear before turning off the motor.

5. Get out of the vehicle; open the doors carefully to avoid damaging them on the Lift.
6. Locate the manufacturer's recommended Lifting Points for the vehicle you are raising.

If you are unsure where the Lifting Points are, consult *Vehicle Lifting Points for Frame Engaging Lifts*, which is provided with the Lift, or the manufacturer of the vehicle. If you no longer have

Vehicle Lifting Points for Frame Engaging Lifts, contact BendPak Support email support@bendpak.com or call **(800) 253-2363**, follow the prompts to secure a replacement copy.

Some vehicles may have the manufacturers' recommended Service Garage Lift Point locations identified by a triangle mark on the underside of the vehicle, reference SAE J2184- (Current Edition). On some vehicles, specific Lifting Points are indicated by a label located on the driver's side door jamb.

⚠ WARNING Do not estimate the best location for the adapters. **You must use the manufacturer's recommended lifting points.** If you do not, the vehicle could become unstable and fall, which could damage the vehicle, damage the Lift, or injure or even kill anyone under the vehicle.

⚠ WARNING Many specialty or modified vehicles or vehicles with unusually short or long wheelbases cannot raised on a Two-Post Frame Engaging Lift. Contact the vehicle's manufacturer for lifting or jacking guidance.

The following figure illustrates typical lifting points based on vehicle frame type.

Typical Lifting Points

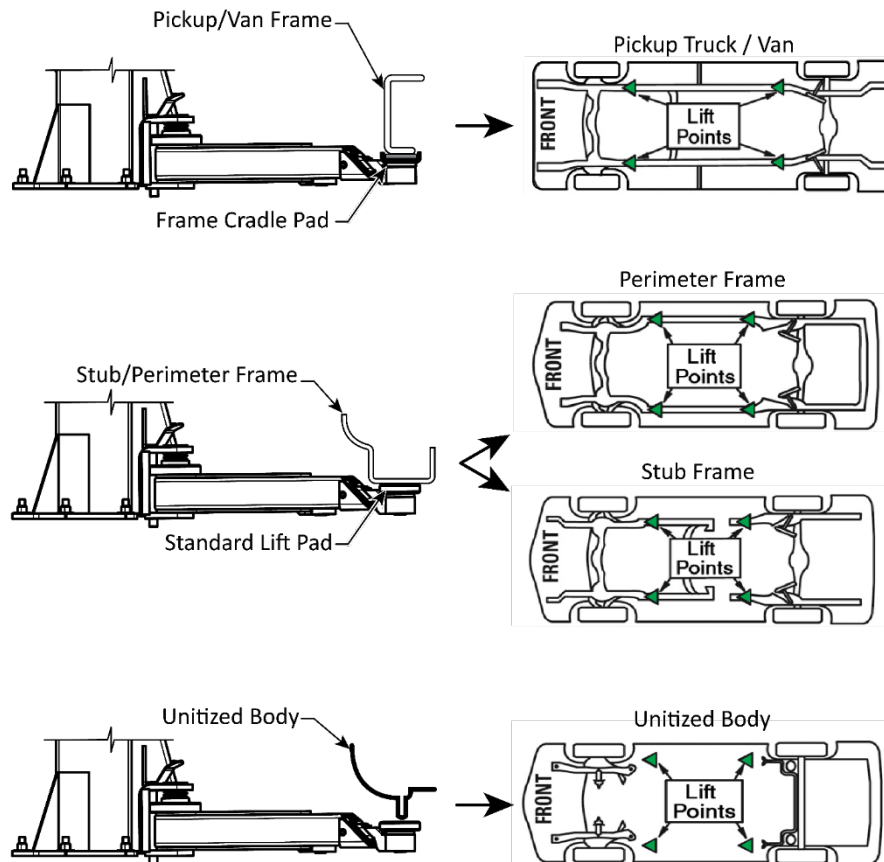

⚠ WARNING Before attempting to lift a vehicle verify:

- The vehicle frame is strong enough to support its weight and has not been weakened or compromised by modification, damage, or corrosion.
- The vehicle individual axle weight does not exceed one-half the Lift capacity.

- All- Lift adapters are in secure contact with the frame at the vehicle manufacturers' recommended Lift Points.
- The vehicle is stable on the Lift, and the center of gravity is not shifted, making the vehicle off balance.
- The overhead switch bar will contact the highest point on the vehicle.

⚠ WARNING Always use Safety Stands when removing or installing heavy components that may affect the vehicle's Center of Gravity.

7. Adjust the lift arms under the vehicle until the adapters are **directly under** the Lifting Points for the vehicle you are raising. If necessary, use the included Auxiliary adapters for extra height.

The vehicle's Lifting Point locations and Center of Gravity will determine if the Lift is configured in an Asymmetric or Symmetric Configuration.

In an Asymmetric Configuration the Centerline of the vehicle is behind the Lift Posts.

In a Symmetric Configuration the centerline of the vehicle is lined up at the Lift Posts.

Refer to the figure below.

Asymmetric Configuration

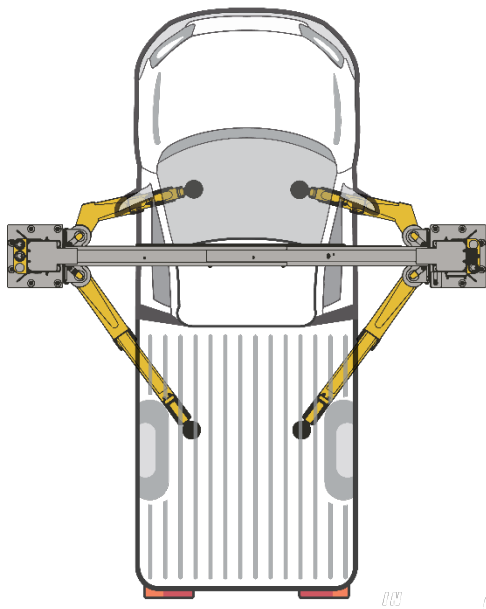

Symmetric Configuration

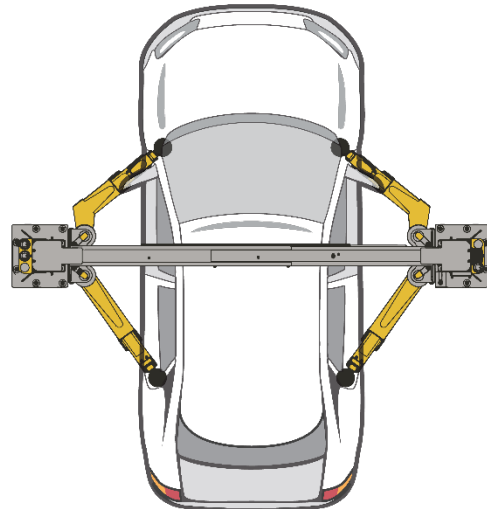

Reference only – do not scale.

8. Raise the Lift until **just before** the adapters contact the Lifting Points.
9. Check the Arm Restraint Gears on all four lift arms to make sure they are engaged.
If they are not engaged, move the lift arms back and forth until they engage.
10. Raise the Lift until the tires of the vehicle are a few inches off the ground.
11. Verify all four adapters are making solid contact with the Lifting Points.

If any of the adapters are **not** making solid contact with the Lifting Points, carefully lower the Lift and start over again; the adapters **must** make solid contact with all Lifting Points.

12. Gently rock the vehicle to make sure the vehicle is stable and balanced.

- If the vehicle is not stable and balanced, lower the Lift back to the ground and start over.
- If the vehicle is stable and balanced, raise it to the desired height.

 **DANGER** Do not raise the Lift farther until the vehicle on the Lift is both stable and balanced. If the vehicle is **not** stable and balanced, it could fall, which could damage the vehicle, damage the Lift, as well as injure or kill anyone under the vehicle.

 **WARNING** Ensure personnel and objects are always clear of the Lift when operating. Always keep a clear line of sight on the Lift.

 **WARNING** Remain Clear of the elevated Lift until visual confirmation is made that all safety locks are fully engaged, and the Lift is lowered onto the safety locks.

13. Press and hold the **Up** Button.

14. Listen as the Lift passes the safety locks; you should hear a thump as each side passes by the safety locks at approximately the same time.

15. When the vehicle reaches the desired height, go past the next safety lock position (you will hear the thump as it passes), then release the **Up** Button.

16. *Press and hold* the lowering handle, which lowers the Lift onto the safety lock position you just passed. Do **not** hold the safety lock release handle while lowering onto the safety locks.

17. When the Lift stops moving down, it is engaged on its safety locks; release the lowering handle.

Do not leave the Lift controls unless the Lift is engaged on its safety locks or fully lowered.

18. Recheck the adapters to verify they are all still making solid contact with the lifting points.

19. Verify the Lift is engaged on the **same safety lock** on both posts.

 **DANGER** Always ensure both safety locks are engaged. If the Lift Heads are engaged on safety locks at two different heights or only one safety lock is engaged, the vehicle could become unbalanced and fall causing damage, injury, or death.

20. Support the vehicle with Jack Stands in case the vehicle becomes unbalanced while working.

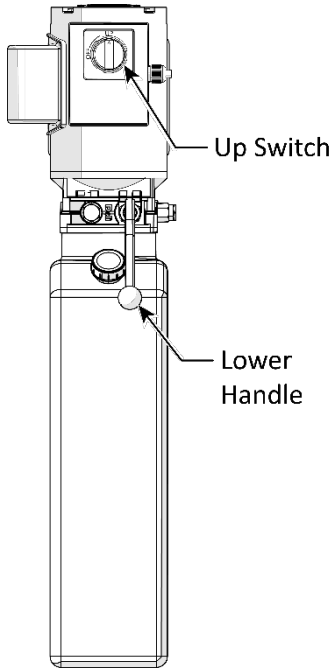
| | | |
|---|---|---|
| <p>To raise the Lift:</p> <ol style="list-style-type: none"> 1. Rotate and hold Up Switch. 2. When Lift is just past desired height, release the Up Switch. 3. Press and hold lowering handle. <p>Do not pull down the safety lock release handle. If you do, the Lift will continue to lower and will not engage on its safety locks.</p> <p>The Lift will engage on a safety lock and stop moving; release lowering handle when Lift stops.</p> <p><i>Only leave Lift on safety locks or fully lowered.</i></p> |  <p>The diagram shows a vertical lift column. At the top, there is a control panel with a circular dial labeled 'Up Switch'. Below this, there is a mechanism with a handle labeled 'Lower Handle' pointing to a circular button on the side of the column.</p> | <p>To lower the Lift:</p> <ol style="list-style-type: none"> 1. Rotate and hold Up Switch for two to three seconds. This moves Lift off its safety locks. 2. Pull down and hold safety lock release handle <i>and</i> lowering handle simultaneously. The Lift begins to lower. 3. When Lift is fully lowered, release the safety lock release handle and lowering handle. <p><i>Only leave Lift on safety locks or fully lowered.</i></p> |
|---|---|---|

Lowering a Vehicle

To lower a vehicle off the Lift, first raise it a small amount to get it off its safety locks, then lower it.

To lower a vehicle off the Lift:

1. Check under and around the vehicle to make sure the area is clear of all obstructions. If you find any obstructions, **move them out of the way**. Verify all personnel are well clear of the Lift.
2. Press and hold the **Up** Button for a second or two to move the Lift off its safety locks.
Raise the Lift at least two inches to get clear of the safety locks.
3. Pull down and hold the safety lock release handle (on the power side post above and to the right of the power unit).
4. Push and hold the lowering handle (on the front of the power unit). The Lift begins lowering.

NOTICE

Both the safety lock release handle **and** the lowering handle must be held down at the same time to lower the Lift.

WARNING

Do not override the Lift controls. For safety purposes, Lift controls are designed to stop the Lift if released. Overriding the Lift controls could lead to damage to the Lift, damage to the vehicle on the Lift, injury, or in rare cases, death to persons nearby.

CAUTION

Remain clear of the Lift as it comes down; obey the pinch point warning decals.

5. When the Lift is on the ground, release both Handles, then rotate all four lift arms to their full drive-through positions to allow an unobstructed exit for the vehicle.
6. Carefully drive the vehicle out.

About Safety Locks

A safety lock **position** is defined as when the Lift is engaged on both Lift's safety locks at the same height on both Posts. Having multiple safety lock positions allows you to lock the Lift at the best height for what you need to do.

CAUTION

Verify that both safety locks are engaged at the same height on both Posts. The Lift should not be engaged on safety locks of two different heights or the safety lock on one Post engaged but the safety lock on the other Post not engaged.

Safety lock positions are created by the safety lock weldments, on the back of each Lift Head.

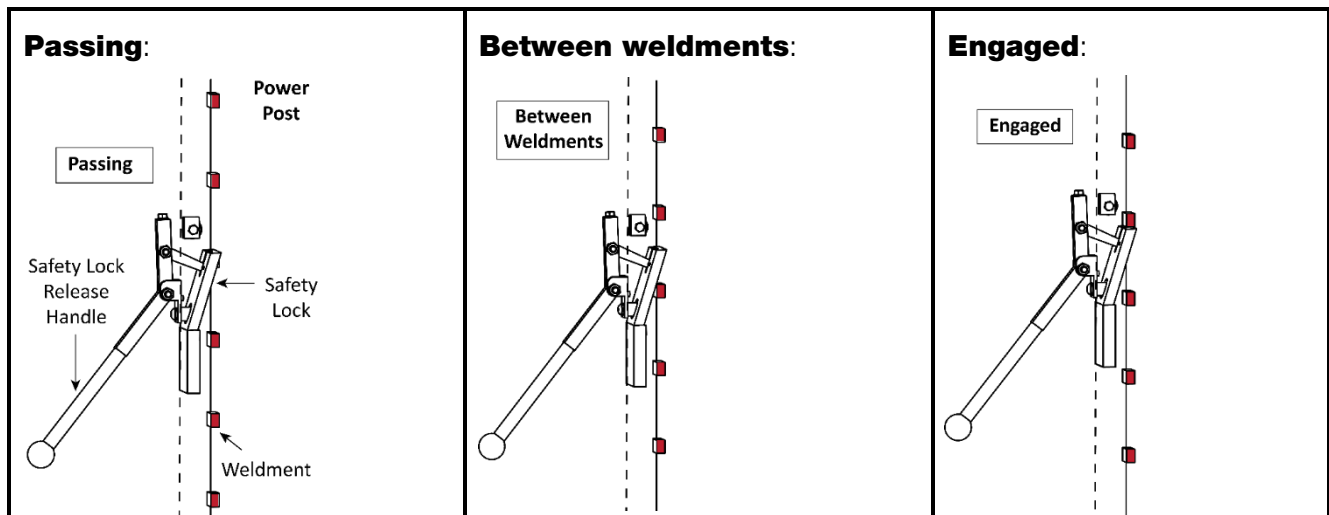

As the safety weldments move past the safety locks, the weldments push the safety lock and the safety lock release handle down. When the weldment is completely past the safety locks, the safety lock Spring pulls the Lock back into place. This happens each time safety locks are passed, so you will generally be hearing multiple clanks as the Lift rises and lowers.

To engage the Lift on a safety lock position, press the **Up** Button and wait until the vehicle reaches the desired height for the work you are going to do, then listen for the clank as the weldments pass the next safety lock position. When you hear the clank, release the **Up** Button, and then hold down the lowering handle (on the front of the power unit) for a second or two to back the weldments down onto the just-passed safety locks; **do not** hold down the safety lock release handle.

 **WARNING** Only leave the Lift either fully lowered or engaged on safety locks. ***If you leave the Lift raised but not engaged on safety locks, the vehicle is not secure.*** It could fall, possibly damaging the vehicle, the Lift, and injuring anyone under the vehicle.

Maintenance

⚠ DANGER Before performing any maintenance on your Lift, verify it is completely disconnected from power. The Lift uses electrical energy; if your organization has Lockout/Tagout policies, make sure to implement them before performing any maintenance. If you come into contact with high voltage, you could be injured or killed.

⚠ DANGER Do not use the Lift if the cables are damaged or extremely worn. If a vehicle is raised when you notice the damage or extreme wear, very carefully lower the vehicle to the ground. When the Lift is on the ground, remove it from service, disconnect it from power, and make arrangements for repair.

⚠ DANGER Always wear proper Personal Protective Equipment (PPE) when working with hydraulics. Gloves and Safety Glasses are a minimum requirement. Keep your body away from suspected leaks. Use a clean piece of sheet metal to pass along hoses and fittings to detect leaks. Shut down the equipment if a leak is suspected or

⚠ WARNING Do not operate your Lift if you find maintenance issues; instead, remove it from service and correct the maintenance issues. Technical support and service is available from your dealer, on the Web at [bendpak.com/support](https://www.bendpak.com/support), by email at support@bendpak.com, or by phone at (800) 253-2363, follow the prompts to reach support. Online chat is also available at <https://www.bendpak.com> click the chat icon.



Read the Installation and Operation manual and understand how this equipment operates before using, maintaining, or repairing. Routine maintenance and adjustments are the responsibility of the owner/user and are not covered under warranty.

Routine maintenance and adjustments should be carried out on a regular basis as outlined below. *Unless stated otherwise, all maintenance may be performed by the owner/employer and does not require trained lift service personnel.* Replace worn, damaged or broken parts with original BendPak or BendPak approved parts or with parts that meet or exceed the original specifications.

Maintenance and Interval Recommendations:

This lift's service life is dependent on the level and frequency of care and maintenance you provide. By simply following a few guidelines, you can increase the life of your lift by many years. The following care and maintenance procedures are intended to ensure safe operation and early detection of problems.

Tools required:

- Open End Wrench Set
- Screwdrivers (Phillips and slotted)
- Hydraulic fluid (same type and weight as the current fluid in use.)
- Clean shop towels
- Hex Key Set
- Lubricants
 - White Lithium Multi-Purpose Lubricant
 - Red Lithium Grease
 - ALMASOL Wire Rope Lubricant or 90W Gear Oil

The following maintenance and interval recommendations are based on typical workday use and operation.

Daily Maintenance

1. Keep the Lift and work area clean, to promote both safety and better problem visibility.
2. Visually inspect that the safety locks are in good operating condition. Do not use your Lift if the safety locks are damaged or excessively worn. Check for wear and adjust the tension on the equalizing cables.
3. Check the hydraulic fluid level in the reservoir. Add fluid, if necessary.
4. Check for hydraulic fluid leaks on hoses, fittings, and cylinders. Inspect for damage. Hose covers that are cut, cracked, blistered, show signs of abrasion, kinking or flattened are to be replaced. cylinder ports that are cracked, show signs of leaking or other damage.
5. Start the hydraulic system and pass a clean piece of sheet metal near the hydraulic hoses, fittings, and cylinders. hydraulic fluid on the metal indicates a leak. Shut down the system and tagout the Lift to prevent use until repaired.
6. Verify the cylinder clamp is in place and tight on both hydraulic cylinders just above the Lift head.

Monthly Maintenance

1. Remove, clean, and apply new Red Lithium grease to all cable sheave Pins as outlined in the Lubrication Procedure.
2. Inspect the condition of all equalizing cables and mechanisms. Run a shop towel over the cable surface while watching for snags. Replace as required.
3. Inspect all hydraulic hoses, fittings, and cylinders for damage and leaks.
4. Apply 90-WT gear oil or ALMASOL® Wire Rope Lubricant to both equalizing cables.
5. Apply White Spray Lithium MP grease to the four inside contact corners of both posts.
6. Apply White Spray Lithium MP grease to all Lift Arm Pivot Points.
7. Inspect all Lift Arm Pins and locking mechanisms for damage and wear. Replace as required.
8. Verify all fasteners are torqued to specifications.
9. Verify all Warning labels are in good condition and legible.

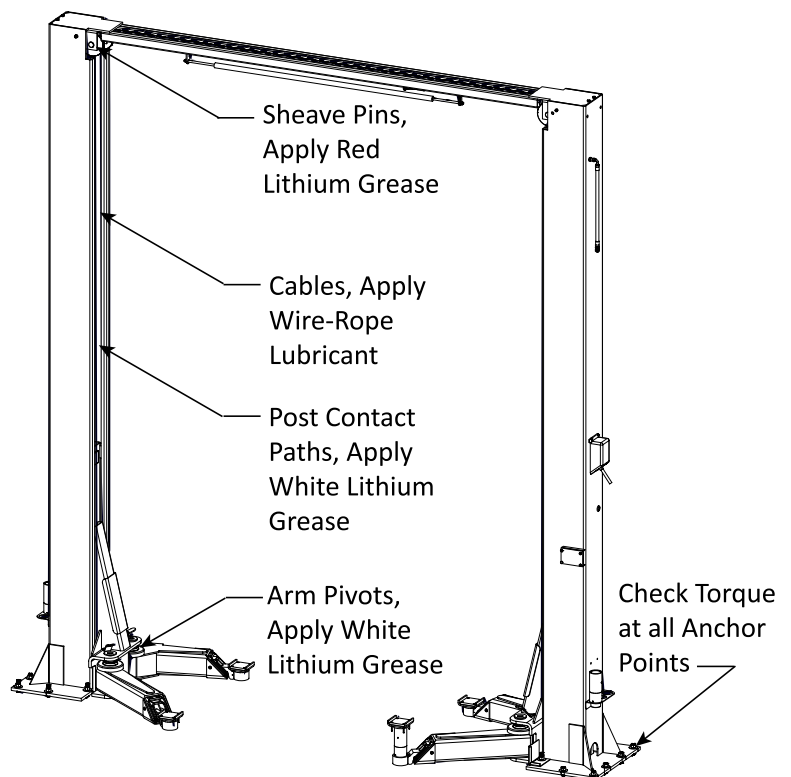

Every Two Months

Verify all anchor bolts are secure and torque to 85-95 ft.-lbs.

Every three to five years or as required

1. Carefully check the equalizing cables for signs of damage or extreme wear. See [Wire Rope Inspection and Maintenance](#) for additional information.

If the Lift becomes inoperative in a raised position, refer to the [Troubleshooting](#) section.

Hydraulic System Maintenance

There is no scheduled replacement period on the hydraulic components in this system. All hydraulic system components are considered “On Condition” maintenance. Inspect periodically as outlined in the previous maintenance section and replace as required.

⚠ WARNING BendPak Does not supply hydraulic fluid with this Lift. **Always** refer to the Safety Data Sheet (SDS) for safe handling and disposal information. SDS are available from the hydraulic fluid supplier or manufacturer.

⚠ WARNING Hydraulic fluid contains toxic components and must be disposed of in accordance with all national, state, and local regulations. See **Disposing of Used Hydraulic Fluid**. Wear appropriate personal protective equipment for working with hydraulic fluid including gloves, and safety glasses.

NOTICE! BendPak does not authorize field repair of the power units. Field adjustment of the Pressure Relief Valve (PRV) is not permitted.

The hydraulic system on this Lift should be inspected as required, but at a minimum interval not to exceed one year. **Repairs to the hydraulic power unit and adjustments to the PRV are not authorized.** Be advised there are no drains or test points in this hydraulic system.

Maintenance activities consist of:

1. Inspecting the cylinder rod.
2. Hydraulic fluid inspection for contamination and verifying the fill level.
3. Inspecting and cleaning the hydraulic fluid filter.
4. Inspecting the hydraulic hoses and/or lines.
5. Inspecting the reservoir and reservoir cap.

⚠ DANGER The power unit on this Lift is a hydraulic pump capable of developing pressures in excess of 5,000 psi (345 BAR). A pressure relief valve is used to set the pressure at the desired level. Tampering with, adjusting, modifying, or removing the relief valve is extremely dangerous and is not permitted.

⚠ DANGER All hydraulic components on this Lift are assumed to be pressurized unless the lift arms have been lowered to the ground and the lowering handle (valve) has been held in for at least ten seconds in which case the entire system is considered depressurized.

Tools Required:

| | | |
|--|--|--|
| <ul style="list-style-type: none">• Clean Shop Towels• Hydraulic Fluid Spill Kit – rags and oil absorbent material• Clean clear glass container to examine the fluid sample. | <ul style="list-style-type: none">• Open end wrench set• Screwdrivers• Ladder• JIC fitting cap/plug | <ul style="list-style-type: none">• Funnel• Clean tube to draw a fluid sample.• Waste fluid containers |
|--|--|--|

Hydraulic Maintenance Start-up

1. Review the Installation and Operation Manual before attempting this procedure.
2. Read and understand all Danger, Warning, and Caution labels on the Lift. If any labels are illegible, contact BendPak to arrange for replacement labels.

-
3. Walk around the Lift and examine it carefully for damaged or worn mechanical components. If such components are found, have the components replaced or repaired.
 4. Look for hydraulic fluid on the ground or on the Lift that could indicate a leak in the hydraulic system.
 5. Verify all hydraulic connections are tight.
 6. Check the hydraulic fluid level in the power unit's reservoir.
 7. Remove the polyethylene cover on each Lift head to enable a view of the cylinder rod.
 8. Verify all lift arms are on the ground. Hold in the lowering handle (Valve) for ten seconds to verify there is no pressure in the system.
 9. Verify the area is clear and all personnel are clear of the Lift and are in no danger from the Lift.
 10. Move the power disconnect switch to the On position.
 11. Verify power is supplied to the Lift by briefly pressing the up button. The power unit will start up.
 12. Raise the Lift arms to the top safety lock with no load on the Lift.

Inspect the Cylinder Rod

1. A ladder may be required to access the top of the Lift head. Visually inspect the rod for wear, corrosion, and pitting. These conditions may lead to leaking seals and moisture intrusion into the hydraulic fluid. If any of these conditions are found, the cylinder may need to be replaced.

Contact BendPak support at bendpak.com/support, via email at support@bendpak.com, or by phone at **(800) 253-2363**, follow the prompts to reach support.
2. If the cylinder rod is in good condition, replace the polyethylene covers and repeat the procedure on the remaining Lift cylinder.
3. Lower the Lift's arms until they rest on the ground.
4. Hold the Lowering Control in for about 10 seconds after the lift arms are resting on the ground to ensure the hydraulic system is depressurized.
5. Turn the Lift's power disconnect to the off position. Lockout/Tag Out the power disconnect to prevent unintentional start up during the maintenance procedure.

Inspect the Hydraulic Fluid for Contamination and Fill Level

1. Remove the reservoir cap and draw a small sample of hydraulic fluid from the power unit. Use a small, clean tube to reach into the reservoir. Cover the end with your thumb and remove a small sample. Place the sample into a clean, clear glass container.
2. Examine the hydraulic fluid sample visually.
 - i. Clean hydraulic fluid ranges from almost clear to an amber color.
 - ii. When the hydraulic fluid becomes dark, then it should be drained from the system and replaced with new clean hydraulic fluid.
 - iii. If solids are visible suspended in the fluid or found at the bottom of the container, the hydraulic fluid should be drained and replaced with new fluid.
 - iv. Fluid with a milk-like tint indicates water in the hydraulic system. Remove all fluid from the system and replace it with new clean hydraulic fluid.
 - v. A change in the smell of hydraulic fluid may indicate contamination. Excessive air trapped in the fluid may create nitrogen compounds which can emit a turpentine-like odor. If a distinct

change in the odor of the fluid is noted, remove all fluid from the system and replace it with clean hydraulic fluid.

3. Verify the fill level by visually comparing the level inside the reservoir with the markings on the exterior of the reservoir.

Inspect the Hoses/Lines and Fittings

1. Inspect all hydraulic hoses for swelling, pinching, kinking, fraying, bubbling, or other abrasions. Damaged hoses are to be replaced before they fail in service.
2. Inspect metal hydraulic lines for dents, and corrosion. Damaged hydraulic lines are to be replaced before they fail in service.
3. Inspect hydraulic fittings to verify they are tight and undamaged. Tighten or replace as required.

Inspect the Reservoir and Cap

1. Reservoir caps are to be kept clean to prevent the migration of debris into the hydraulic system.
2. Inspect the cap and reservoir for cracks, verify any filter material in the cap is clean. Rinse in clean fluid, if required.
3. If the reservoir, its cap, or seal is damaged, contact BendPak for replacement parts.

Draining The Hydraulic System

Draining the hydraulic system and replacing the fluid should only be undertaken if the fluid is contaminated. There are no drain valves, test points, or strainers with magnets on this Lift's hydraulic system. Gather rags and oil absorbent material in case of fluid spills. BendPak advises an assistant to be available to aid in keeping fluid spills to a minimum.

1. Retrieve a container capable of storing the 3.6 gal. of hydraulic fluid from the system.
2. With the lift arms resting on the ground and the Power Disconnect in the off position, hold down the lower lever (valve) for about 10 seconds to verify the system is depressurized. All components of the hydraulic system will be depressurized.
3. Open the system at the hydraulic hose connection routed from the power unit to the JIC Tee on the power side post. Quickly plug the tee fitting with a JIC cap. Use rags to minimize any spilled hydraulic fluid.
4. Place the end of the hydraulic hose just removed from the tee into the waste fluid container.
5. Press the raise button while holding the hose in the container. Release the button when air begins to escape the hose.
6. Place a small waste oil container near each cylinder. Open the JIC Connector on the off side post cylinder and place that end of the hydraulic hose into the container. Cover the off side post cylinder JIC connector with a rag to absorb any fluid continuing to leak from the cylinder.
7. Open the JIC hose connection on the power side cylinder and place the hose end into the waste container to capture the fluid exiting the hose.



Inspect and Clean the Filter

1. An assistant is recommended for this inspection. Gather tools for removal and oil clean-up supplies in case of a spill.
2. Remove the power unit's reservoir. The reservoir is awkward to handle. Have an assistant support the reservoir while it is loosened.
3. Remove the 100 mesh filter at the bottom of the suction pipe.
4. Inspect the filter for debris. If excessive amounts of debris are found:
 - i. Thoroughly rinse the filter in clean hydraulic fluid to remove contaminants.
 - ii. Dispose of the waste hydraulic fluid in accordance with national, state, and local regulations.
5. When the screen is clean, replace the filter on the suction pipe.
6. Use clean hydraulic fluid and rags to clean the reservoir.
7. When the reservoir is clean, install the reservoir on the power unit.
8. Fill the reservoir with clean hydraulic fluid.
9. Reconnect all hydraulic hoses and verify they are tight and undamaged.
10. Dispose of rags and oil absorbent material in accordance with all national and local regulations.

Hydraulic System Spare Parts

| Part Number | Description | Qty./Lift |
|-------------|---|-----------|
| 5570254 | Hydraulic Hose Assembly Ø6.35 X 7950mm SB | 1 |
| 5570238 | Hydraulic Hose Assembly Ø6.4 X 3870mm SB | 1 |
| 5550113 | FTG ELB -04 NPT L x -04 JIC | 2 |
| 5550183 | FTG ELB -06 JIC -06L ORB | 1 |
| 5550003 | FTG TEE -04JIC -04JIC -06JIC | 1 |

Lubrication Procedure

-  **WARNING** BendPak does not supply Lubrication products with this Lift. **Always** refer to the Safety Data Sheet (SDS) for safe handling and disposal information. SDS are available from the lubricant supplier or manufacturer.
-  **WARNING** Some Lubricants may contain toxic components and must be disposed of in accordance with all national, state, and local regulations. Wear appropriate personal protective equipment for working with lubricating products including gloves, and safety glasses.

To Lubricate the Upper Corner Sheaves

1. Raise the Lift Head to rest on at least the first Safety Lock.
2. Remove the Polyethylene Cover from the Lift Head then loosen the cable nut to relax the cable.
3. Lubricate the upper corner sheave.
 - a. Remove Screw securing pin at the upper sheave.
 - b. Remove the pin from the sheave.
 - c. Apply red lithium grease to the pin.
 - d. Reinstall the sheave pin through the sheave then insert and tighten screw.
 - e. Tighten the cable nut.
 See Leveling Section to readjust lift arms.

To Lubricate the Lower Sheaves

1. Relax equalizing cables, as outlined above.
2. Unscrew the sheave pin fastener.
3. Remove sheave pin.
4. Apply red lithium grease to sheave pin.
5. Reassemble and tighten.

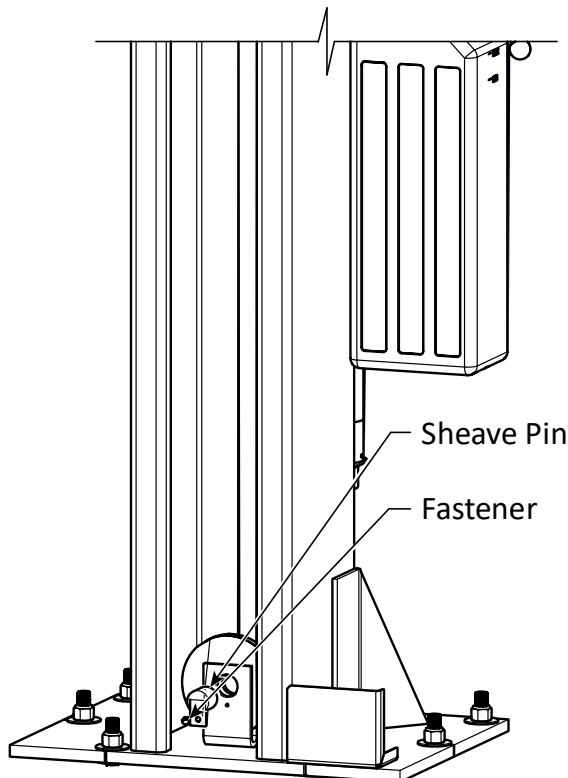

3. a. Remove Screw
- b. Remove Pin
- c. Apply Grease
- d. Put in Sheave
- e. Tighten Cable

2. Loosen Nut to Relax Cable

1. Raise Lift Head to rest on Safety Lock

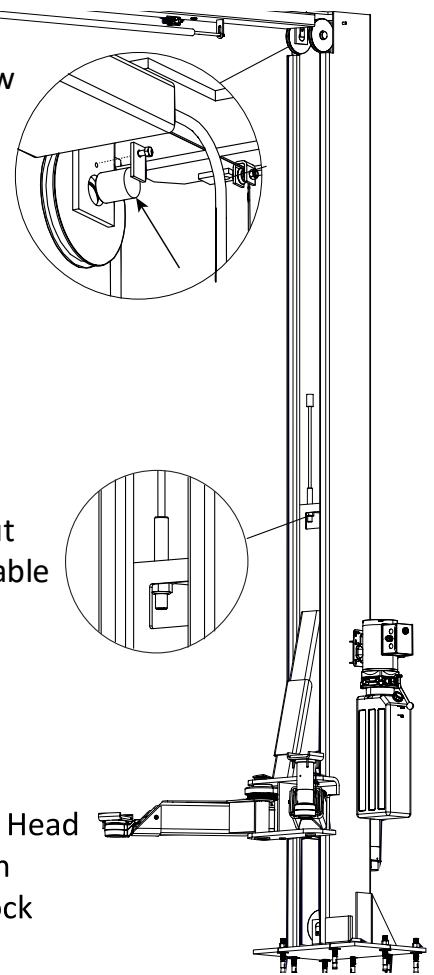

12APX Wire Rope Inspection and Maintenance

The 12APX equalizing cables should be inspected regularly:

- Cables should be replaced when there are visible signs of damage or extreme wear. **Do not use the Lift if it has damaged or worn cables.**
- Lifting cables should always be maintained in a well-lubricated condition.

Wire rope is fully protected when each wire strand is lubricated both internally and externally. Excessive wear shortens the life of wire rope. Use a wire-rope lubricant that penetrates to the core of the rope and provides long-term lubrication between each individual strand, such as 90-WT gear oil or ALMASOL® Wire Rope Lubricant.

To make sure that the inner layers of the rope remain well lubricated, lubrication should be carried out at intervals not exceeding three months during operation.

- All sheaves and guide rollers in contact with the moving rope should be given regular visual checks for surface wear and lubricated to make sure they run freely. This operation should be carried out at appropriate intervals generally not exceeding three months during operation.

For all sheave axles, use standard wheel bearing grease. For all sheaves and/or guide rollers, use 90-WT gear oil or a similar heavy lubricant, applied by any method including pump/spray dispensing, brush, hand, or swabbing.

- How often should the cables be inspected?

Lifting cables should be visually inspected at least once each day when in use, as suggested by American Petroleum Institute's Recommended Practice 54 guidelines. Any lifting cables that have met the criteria for removal must be immediately replaced.

- When should you replace lifting cables due to broken wires?

Lifting cables should be removed from service when you see six randomly distributed broken wires within any one lay length, or three broken wires in one strand within one lay length.

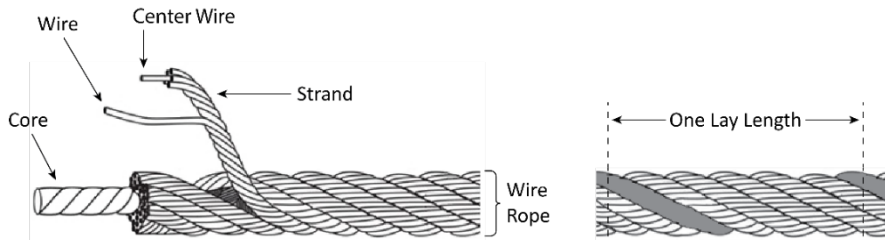



- Are there other reasons to replace your lifting cables?

Yes. Corrosion that pits the wires and/or connectors, evidence of kinking, crushing, cutting, bird-caging, or a popped core, wear that exceeds 10% of a wire's original diameter, or heat damage.

- Finding broken wires:
 - a. Relax the wire rope to a stationary position and move the pick-up points off the sheaves. Clean the surface of the rope with a cloth — a wire brush, if necessary — so you can see any breaks.
 - b. Flex the rope to expose any broken wires hidden in the valleys between the strands.
 - c. Visually check for any broken wires. One way to check for crown breaks is to run a cloth along the rope to check for possible snags.
 - d. With an awl, probe between wires and strands and lift any wires that appear loose. Evidence of broken internal wires may require a more extensive rope examination.

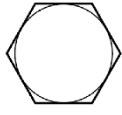
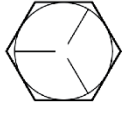
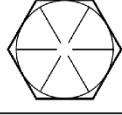
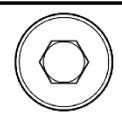
Torque Chart

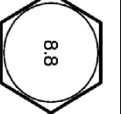
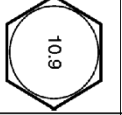
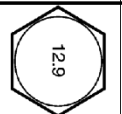
| FASTENER TORQUE CHART | | | | | | | | | | | | | |
|-----------------------|---------------------|---|-----------------------|---|----------------------|---|-----------------------|---|-----------------------|-----------------------|----------------------|-----------------------|-----------------------|
| Bolt Size (SAE) | Bolt Size (Metric) | Tightening Torque | | | Tightening Torque | | | Tightening Torque | | | Tightening Torque | | |
| | | Lubricated (ft.-lbs) | Zinc Plated (ft.-lbs) | Plain & Dry (ft.-lbs) | Lubricated (ft.-lbs) | Zinc Plated (ft.-lbs) | Plain & Dry (ft.-lbs) | Lubricated (ft.-lbs) | Zinc Plated (ft.-lbs) | Plain & Dry (ft.-lbs) | Lubricated (ft.-lbs) | Zinc Plated (ft.-lbs) | Plain & Dry (ft.-lbs) |
| | Bolt Grade (SAE) |  | SAE Grade 0-1-2 |  | SAE Grade 5 |  | SAE Grade 8 |  | Socket Head Cap Screw | SAE Grade | | | |
| | Bolt Class (Metric) |  | Metric Class 4.6 |  | Metric Class 8.8 |  | Metric Class 10.9 |  | Metric Class 12.9 | | | | |
| 1/4-20 | M6 x1.0 | 2.3 | 2.6 | 3.0 | 5.8 | 6.6 | 7.7 | 8.3 | 9.4 | 11.1 | 9.7 | 11.0 | |
| 5/16-18 | M8 x 1.25 | 3.8 | 4.3 | 5.0 | 9.7 | 11.0 | 13.0 | 13.9 | 15.8 | 18.5 | 16.3 | 18.4 | |
| 3/8-16 | M10 x 1.50 | 10.8 | 12.3 | 14.4 | 27.9 | 31.6 | 37.2 | 39.9 | 45.2 | 53.2 | 46.7 | 52.9 | |
| 7/16-14 | N/A | 24.0 | 27 | 30.0 | 35.0 | 42 | 50.0 | 55.0 | 59 | 70.0 | 61.0 | 68 | |
| 1/2-13 | M12 x 1.75 | 18.9 | 21.4 | 25.2 | 48.7 | 55.1 | 64.9 | 69.6 | 78.9 | 92.8 | 81.4 | 92.2 | |
| 9/16-12 | M14 x 2.00 | 30.2 | 34.2 | 40.2 | 77.8 | 88.1 | 103.7 | 111.3 | 126.1 | 148.4 | 130.0 | 147.4 | |
| 5/8-11 | M16 x 2.00 | 47 | 53 | 62 | 121 | 137 | 161 | 173 | 196 | 230 | 202 | 229 | |
| 3/4-10 | M18 x 2.50 | 65 | 73 | 86 | 167 | 189 | 222 | 239 | 270 | 318 | 279 | 316 | |
| 7/8-9 | M22 x 2.50 | 136 | 155 | 182 | 320 | 365 | 430 | 460 | 515 | 600 | 510 | 575 | |

WARNING! Prior to installation, inspect all accompanying manuals, parts lists and catalogs to ensure you have all the necessary parts. Identify all fasteners and their proper torque settings as illustrated on this chart. Proper torquing practices cannot be over emphasized. Torque values are provided as a convenient method of achieving correct pre-loading of highly stressed fasteners. If the fasteners are not properly plated, the fastener threads are not clean and free of deformation, or are not properly lubricated, the correct fastener pre-load will not be achieved even though the given torque value is reached. For this reason, it is critical that all fasteners be inspected for proper plating, thread form and correctly lubricated prior to torquing. Failure to verify a fastener's serviceability or to correctly lubricate the fastener prior to assembly and torquing will result in the fastener not being properly pre-loaded and subsequent failure of the fastener may occur. The torque values can only be achieved if the nut (or tapped hole) has a proof load greater than or equal to the bolt's minimum ultimate tensile strength. Clamp loads estimated as 75% of proof load for specified bolts. Torque values are listed in foot-pounds. Torque wrenches should be calibrated on an annual basis. Never use an impact driver on a torque multiplier.

Troubleshooting

This section describes how to troubleshoot the 12APX Lift.

NOTICE If your Lift is not functioning correctly, you must take it out of service until it is repaired.

Important: Replace worn, damaged or broken parts with original BendPak or BendPak approved parts or with parts that meet or exceed the original manufacturer specifications.

⚠ DANGER Before performing maintenance on your Lift, verify it is disconnected from power. The Lift uses electrical energy; if your organization has Lockout/Tagout policies, implement them before performing any maintenance. If you come into contact with high voltage, you could be injured or killed.

⚠ DANGER Always wear proper Personal Protective Equipment (PPE) when working with hydraulics. Gloves and Safety Glasses are a minimum requirement. Keep your body away from suspected leaks. Use a clean piece of sheet metal to pass along hoses and fittings to detect leaks. Shut down the equipment if a leak is suspected or detected.

⚠ DANGER Prior to removing or tightening **any** hydraulic fitting or hose, verify the Lift Heads are secured on a safety lock or resting on the ground. Push in the Down Lever for an extra five to ten seconds after the Lift Heads have stopped moving to ensure that pressure is relieved from the hydraulic system.

| Issue | Action to Take |
|--|--|
| Lift becomes inoperative in a raised position. | Verify there is sufficient hydraulic fluid in the reservoir. Verify the Lift Carriages are above and clear of the safety locks. Verify none of the hydraulic hoses are pinched or leaking. Verify the power unit is being supplied power. Make sure the Lift is not overloaded. Make sure the load on the Lift is balanced. Contact bendpak.com/support . |
| Arms move erratically or squeak when in use. | Move the lift arms up and down a few times to flush any residual air from the hydraulic system. |
| Off side lift head will not lower. | See broken safety cable procedure below. |
| Lift does not stay up. | Make sure to leave the Lift engaged on its safety locks. Check for hydraulic fluid leaks. |
| Vehicle on Lift is not level. | Make sure Lift is engaged on safety locks at the same height. Make sure the safety locks in both posts are engaged. If either condition is not met, carefully lower the vehicle back down to the ground and raise it again. |
| Motor is not running. | Check connection to power source; verify it is plugged in and the voltage is correct. Verify circuit breaker is not tripped. Check the wiring diagram on the power unit. |
| Hydraulic Fluid is dirty. | Replace the dirty hydraulic fluid with clean, approved ATF fluids, such as Dexron III, Dexron VI, Mercon V, Mercon LV, or comparable. |
| Lift makes odd noises. | Lubricate hinge points using white lithium grease. |

Technical support and service is available from your dealer, on the Web at bendpak.com/support, by email at support@bendpak.com, or by phone at **(800) 253-2363**, follow the prompts to reach support.

Broken Safety Cable Procedure

If the safety cable breaks, the power side Lift head will lower but the off side lift head will not.

To release the off side safety lock:

1. Raise the Lift Heads off the safety locks.
2. Have an assistant reach through the access hole with a stiff wire or pick to pull the Safety Block away from the Lift Head. See figure below.
3. Hold in Safety Release on the power side Lift post while holding the lower handle to power unit.
4. When the Lift heads are on the ground and the Lift is in a safe condition, remove power from the Lift and replace the safety cable.

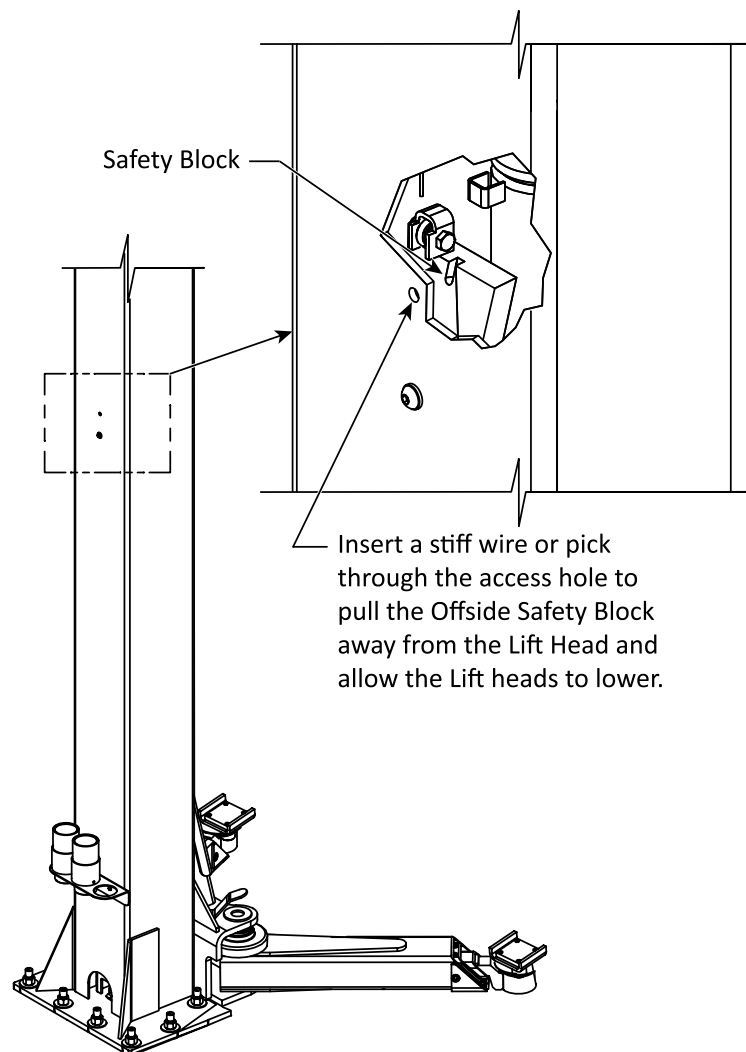

Reference only – do not scale.

Troubleshooting Lift Arm Lock Disengagement

⚠ WARNING Avoid excessive Shim heights! A new concrete cutout and steel reinforced pour are recommended to correct out of level conditions in excess of 3°.

Some floors with excessive out of level conditions may require Shim heights that reach or exceed 0.5 in. (12.7 mm). When the Shim Height reaches this level, the Lift Arm Lock Pins may not function to disengage the lift arms when completely lowered. To correct this condition, the Arm Lock Pins include an M12 x 1.75 internal thread, approximately 12 mm deep. A mating M12 Hex Head Bolt with Lock Washers, or a backing nut (not supplied) may be used to extend the contact point of the Arm Lock Pins. Adjust the Bolt head position to disengage the Lock as required. Refer to the figure below.

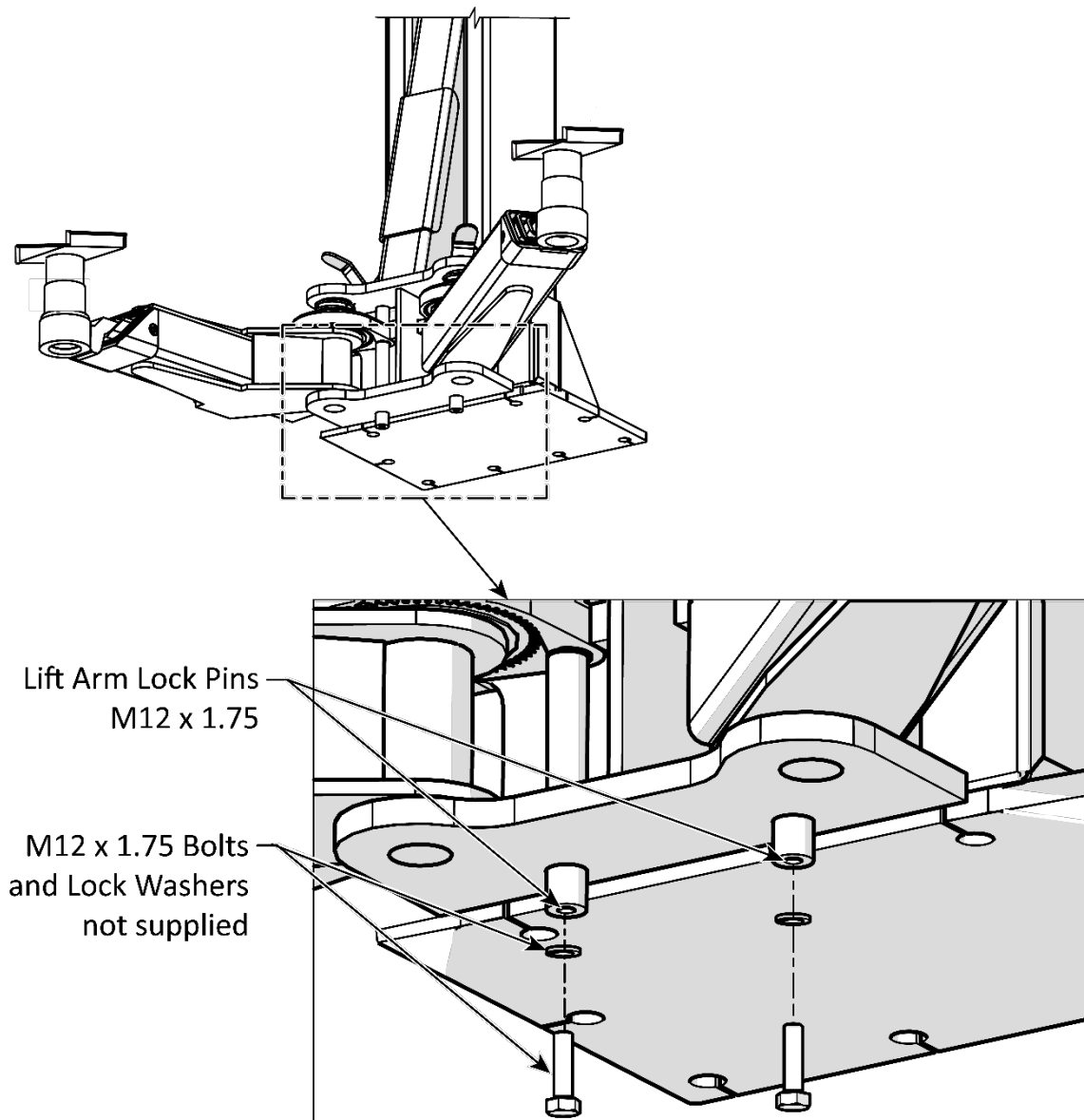

Disposing of Used Hydraulic Fluid

Used hydraulic fluid cannot be disposed of by dropping it into the trash or dumping it into the street. hydraulic fluid has toxic ingredients that are harmful to the environment. Either recycle the hydraulic fluid or drop it off at a hazardous waste collection facility. Dirty or contaminated fluid must be treated as hazardous waste. Rags and/or granular absorbents that have soaked up hydraulic fluid should be treated like hazardous waste and be disposed of at a hazardous waste collection facility.

To find an appropriate facility:

- Local automotive parts stores, auto care facilities, or automobile dealerships may accept fluid for recycling or, in some cases, for disposal. Contact them for more information.
- Cities, counties, and states often support both recycling facilities and hazardous waste collection facilities. Contact them to see if and where they have these programs.

If you are unable to find an appropriate facility, the website earth911.com has resources that may be of help.

Lift Disposal - End of Service Life

Once your Lift has reached the end of its service life it must be disposed of properly. Metal recyclers will be able to advise on methods and costs to remove the Lift and will *reuse* the materials, diverting them from landfills. The best option is to contact a metal recycling center and discuss the size and weight of the Lift to determine if the facility can deconstruct and recover the usable components and metals.

The hydraulic cylinders, Hoses, Fittings, and the power unit itself must be disposed of in accordance with current national, state, and local regulations governing the use and disposal of hazardous materials. These components and any used hydraulic fluid **must not** be disposed of by dropping it into the trash or dumping it into the street. The hydraulic fluid contains toxic ingredients that are harmful to the environment.

These components and the hydraulic fluid are required to be recycled or must be delivered to a hazardous waste collection facility.

If you have large amounts of hydraulic fluid, consider contacting a commercial waste disposal company. In all cases, the best approach is to find an appropriate facility and contact them — in advance — to ask them: what kinds of fluids and materials they accept, what kind of containers they must be in, what hours they are open, their location, and any other information specific to their facility.

If you are unable to find an appropriate facility, the website earth911.com has resources that may be of help.

Wiring Diagrams

This section includes wiring information for the overhead limit switch.

⚠ DANGER All wiring **must** be performed by a licensed Electrician in accordance with all local and national electrical codes. Make sure that main electrical power has been disconnected from the Lift and cannot be re-energized until all procedures are complete. If your organization has Lockout/ Tagout policies, make sure to implement them after connecting the Lift to power.

IMPORTANT! The power unit typically consumes 19.5 FLA at 208-230 VAC, 50/60 Hz., single phase. The electrical circuit should be protected by an appropriate circuit breaker or time-delay fuse chosen by the Electrician taking into account local electrical codes. Typically, this is a 25 Amp circuit breaker.

To Connect the limit switch (Single Phase):

1. Remove and retain the three cover screws and retain the switch cover.
2. For single phase installations, feed the SJO cord through the strain relief in the switch cover.
3. Strip the insulation off two of the conductors and connect to the normally closed (NC) terminals. One wire to terminal 21 and the other to terminal 22.
4. Inspect to verify no stray wire strands are bridging across the terminals. If strands are bridging, correct before proceeding.
5. Replace the Switch Cover and secure with the three screws removed in step 1.

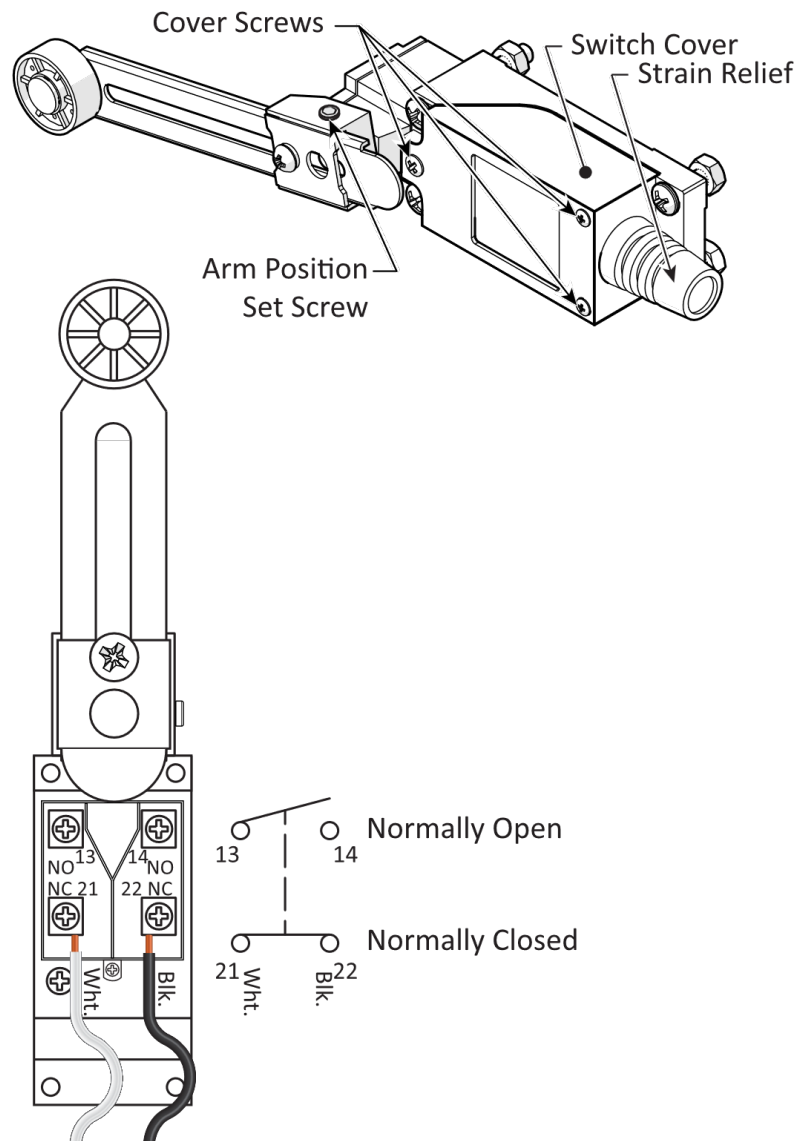

Single-Phase Power Unit Wiring

IMPORTANT! The power disconnect and thermal disconnect are not supplied with this Lift. These components must be provided and installed by a licensed Electrician in accordance with the National Electrical Code (NEC). A thermal disconnect is not required by the NEC but may be required by local code.

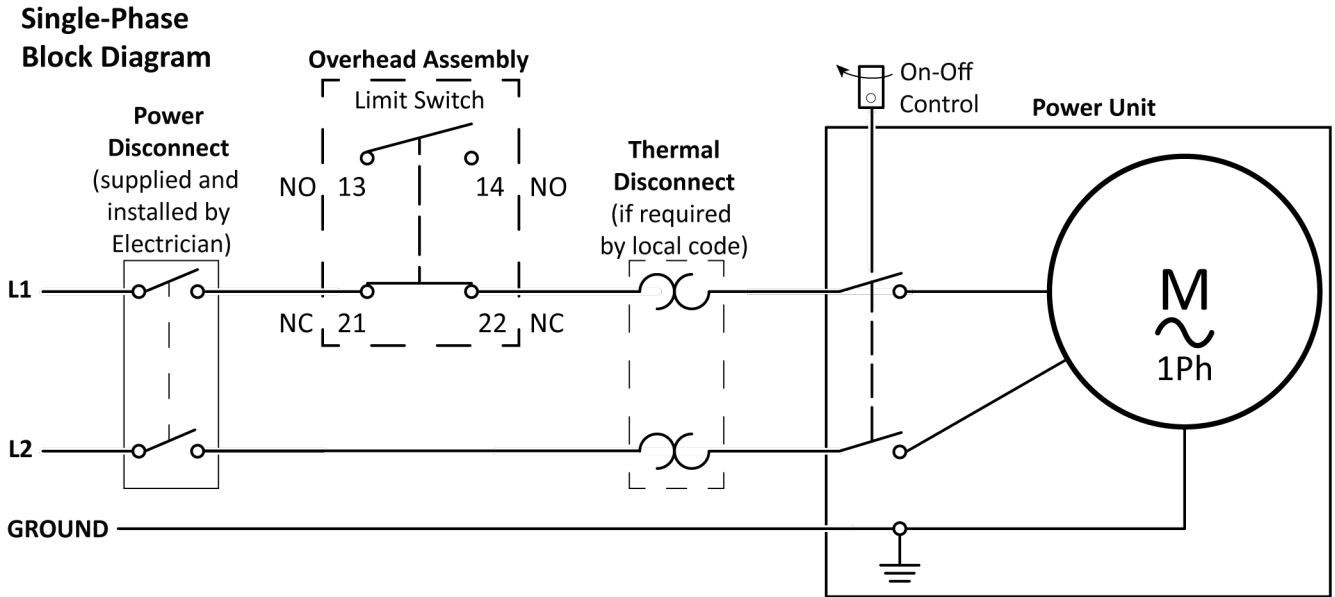

**Power Unit
5585037**

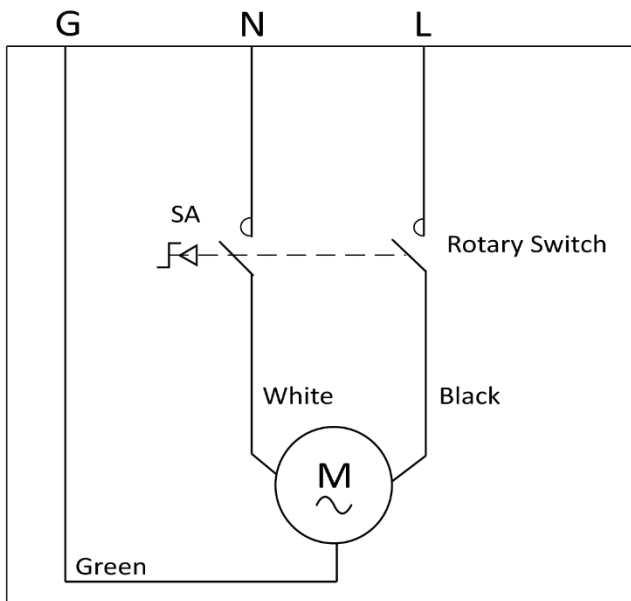

Power Unit Motor
208-240V, 1PH, 50/60 HZ,
2900/3450rpm, 5HP

**Power Unit
5585685**

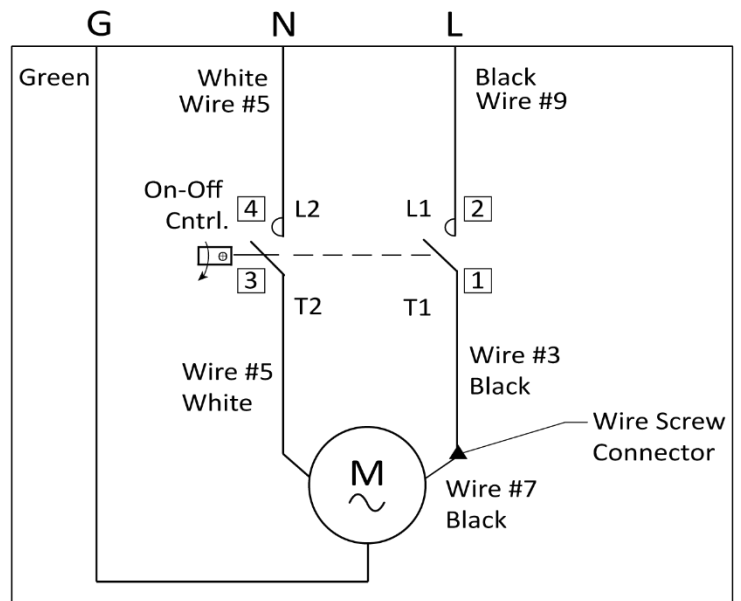

Power Unit Motor
208-230V, 1PH, 50/60 HZ,
2880/3450rpm, 5HP

Three-Phase Limit Switches Installation

This section includes assembly and wiring information for the 3-phase overhead limit switches. Requires the **AP Clear Floor 3-phase Micro Switch Kit part number 5216263**.

⚠ DANGER All wiring **must** be performed by a licensed Electrician in accordance with all local and national electrical codes. Make sure that main electrical power has been disconnected from the Lift and cannot be re-energized until all procedures are complete.

To wire the limit switches (3-phase):

1. Remove and retain the three cover screws on both limit switches.
2. Remove and retain the limit switch Covers.
3. Strip back the jacket of the 14-4 cable about 5 in. (127 mm) to expose the 4 conductors.
4. Push the black and white wires through the strain relief on one switch cover and the red and brown through the strain relief on the remaining cover.
5. Strip the insulation back on all four conductors about 1/2 in. (13 mm) and connect one wire to each side of the *Normally Closed Terminals* on each switch. Refer to the figure below. Inspect to verify no stray or broken wire strands are bridging across the terminals.
6. Replace the switch covers and secure with the three screws removed in step 1.

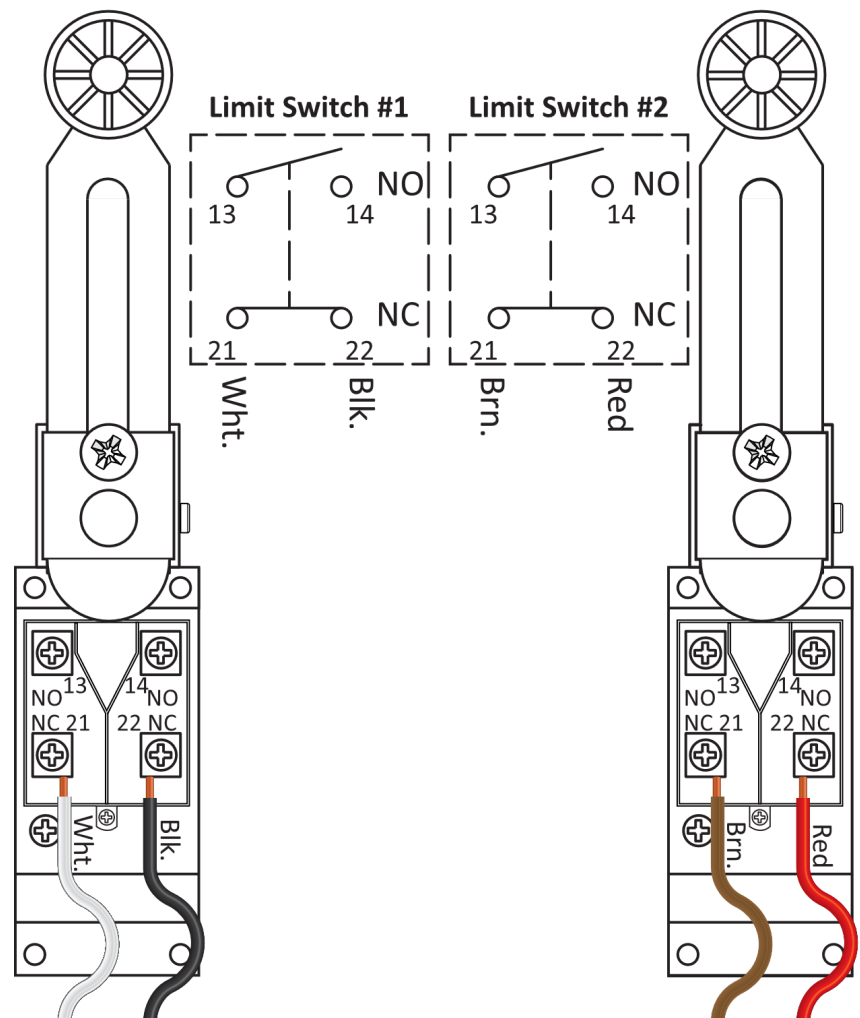

7. Secure the switches to the bracket on the overhead assembly. Refer to the figures below components removed for clarity.
8. Attach the limit switches to the Lift's overhead assembly using the fasteners described below.

| Item | Part Number | Description | Qty. |
|----------|-------------|--------------------------|------|
| A | 5520088 | Rocker Limit Switch | 2 |
| B | 5520116 | Cable, 14-4 SOOW | 1 |
| C | 5530494 | Phillips M4 x .7 x 30 mm | 4 |
| D | 5530492 | Phillips M4 x .7 x 14 mm | 4 |
| E | 5535016 | Nut M4 | 8 |
| F | 5300815 | Limit Stop Bar Cushion | 1 |

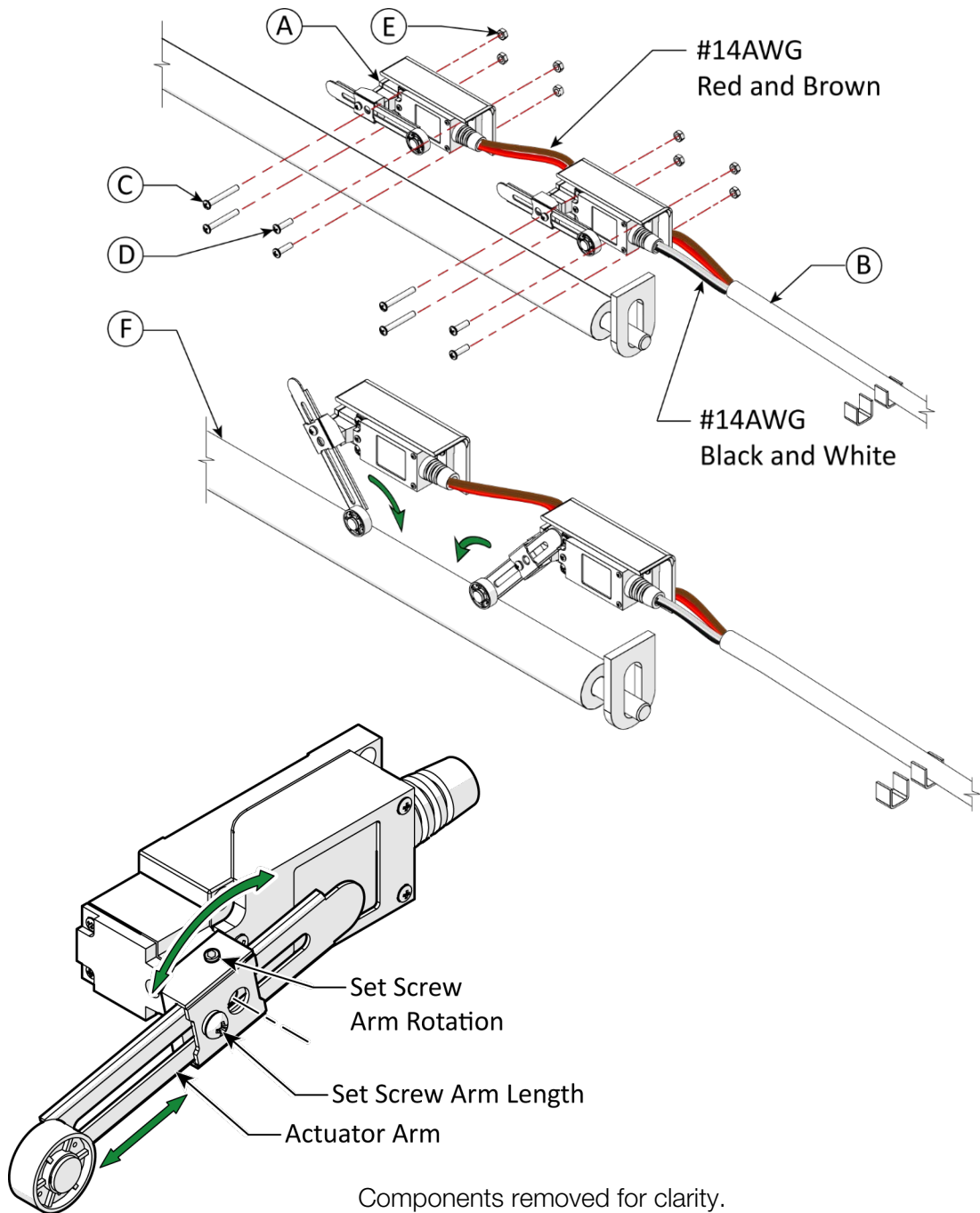

9. Loosen **BOTH** arm rotation set screws and allow the actuator arm to rest on the limit stop bar cushion. Adjust the length of the actuator arm, as required.
10. Tighten the arm rotation set screws on **BOTH** limit switches.
11. Push up on the limit switch stop bar. The limit switches should rise and fall with the stop bar.
12. Route the 14-4 cable through the cable clips across the overhead and down the power side lift post.
13. Bend the cable clips to secure the cable flat against the overhead and the lift post.
14. Verify the cable is held firmly in the cable clips and has little to no slack inside the lift post. Excessive slack could interfere with moving components inside the lift post leading to cable damage and malfunction.
15. Feed the 14-4 cable out through the grommet below the safety lock release.

Three-Phase Power Unit Wiring

IMPORTANT! The power disconnect and thermal disconnect are not supplied with this Lift. These components must be provided and installed by a licensed electrician in accordance with the National Electrical Code (NEC). A thermal disconnect is not required by the NEC but may be required by local electrical code.

⚠ DANGER All wiring must be performed by a licensed electrician in accordance with all applicable local and national electrical codes. Before performing any procedure, disconnect main power to the Lift and ensure it cannot be re-energized until all procedures are complete.

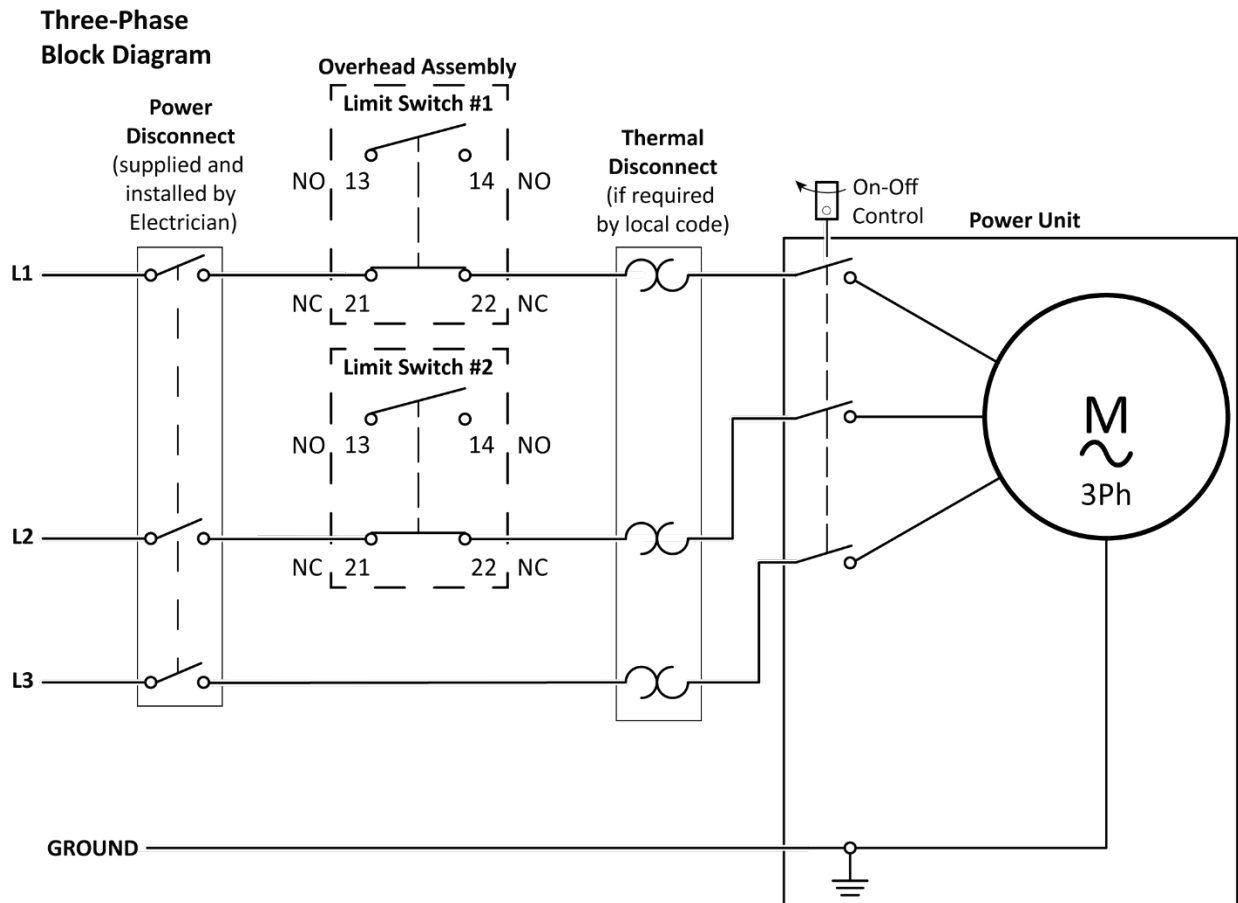

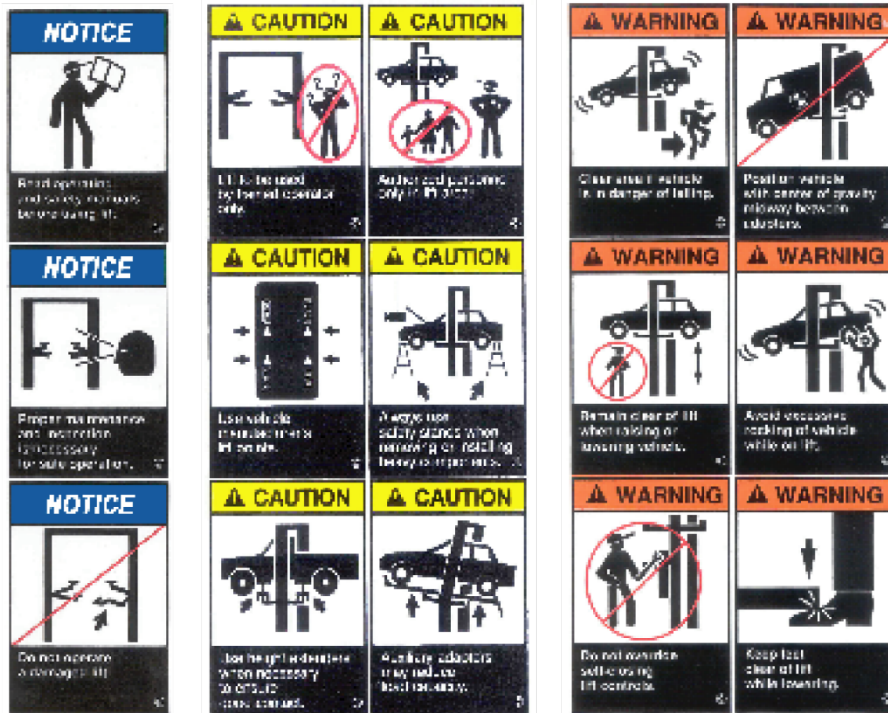
F**J**

TO RAISE LIFT:

1. Press and hold **UP** button.
2. When lift is just **PAST** desired height, release **UP** button.
3. Hold down Lowering Handle. **DO NOT** hold down Safety Lock Release Handle. Lift engages on safety locks.
4. Release Lowering Handle.

TO LOWER LIFT:

1. Press and hold **UP** button for two to three seconds, moving lift off safety locks.
2. Hold down Safety Lock Release Handle **and** Lowering Handle.
3. When lift is fully lowered, release both handles.

PN 5905414

PN 5905414

H

NOTICE

If attachments, accessories, or configuration modifying components used on this lift are located in the load path and affect operation of the lift, affect the lift electrical listing, or affect intended vehicle accommodation; and if they are not certified for use on this lift, then the certification of this lift shall become null and void. Contact the participant for information pertaining to certified attachments, accessories, or configuration modifying components.

www.autolift.org ©2011 by ALI, Inc. ALI / WLSIA01

PN 5905377

K

CALIFORNIA PROPOSITION 65

WARNING! This product can expose you to chemicals including styrene and vinyl chloride which are on the list of over 900 chemicals identified by the State of California to cause cancer, birth defects or reproductive harm. ALWAYS use this product in accordance with the manufacturer's instructions.

For more information, go to www.p65warnings.ca.gov

PN 5905775

L

PN 5906163

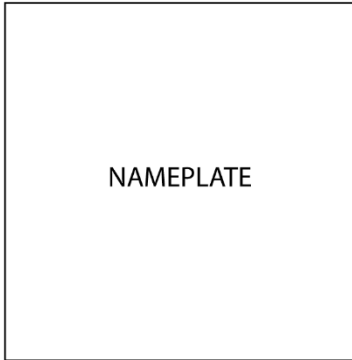
I

PN 5905950

M

CERTIFIED AUTOMOTIVE LIFT

ALI CERTIFIED
INDEPENDENTLY TESTED AND VALIDATED

To the provisions of ANSI/ALI ALCTV-2017 SAFETY REQUIREMENTS FOR CONSTRUCTION, TESTING AND VALIDATION

Automotive Lift Institute, Inc. | Cortland, NY 13045

MET LISTED
Conforms to ANSI/UL 201 SAFETY STANDARD FOR GARAGE EQUIPMENT

NRTL LISTED
MET US

Certified to CAN/CSA C22.2 NO.68 MOTOR OPERATED APPLIANCES (HOUSEHOLD & COMMERCIAL)

MET Laboratories, Inc. BALTIMORE, MD 21230

Certification Label Serial Number

AL00617000M

PN 5905654

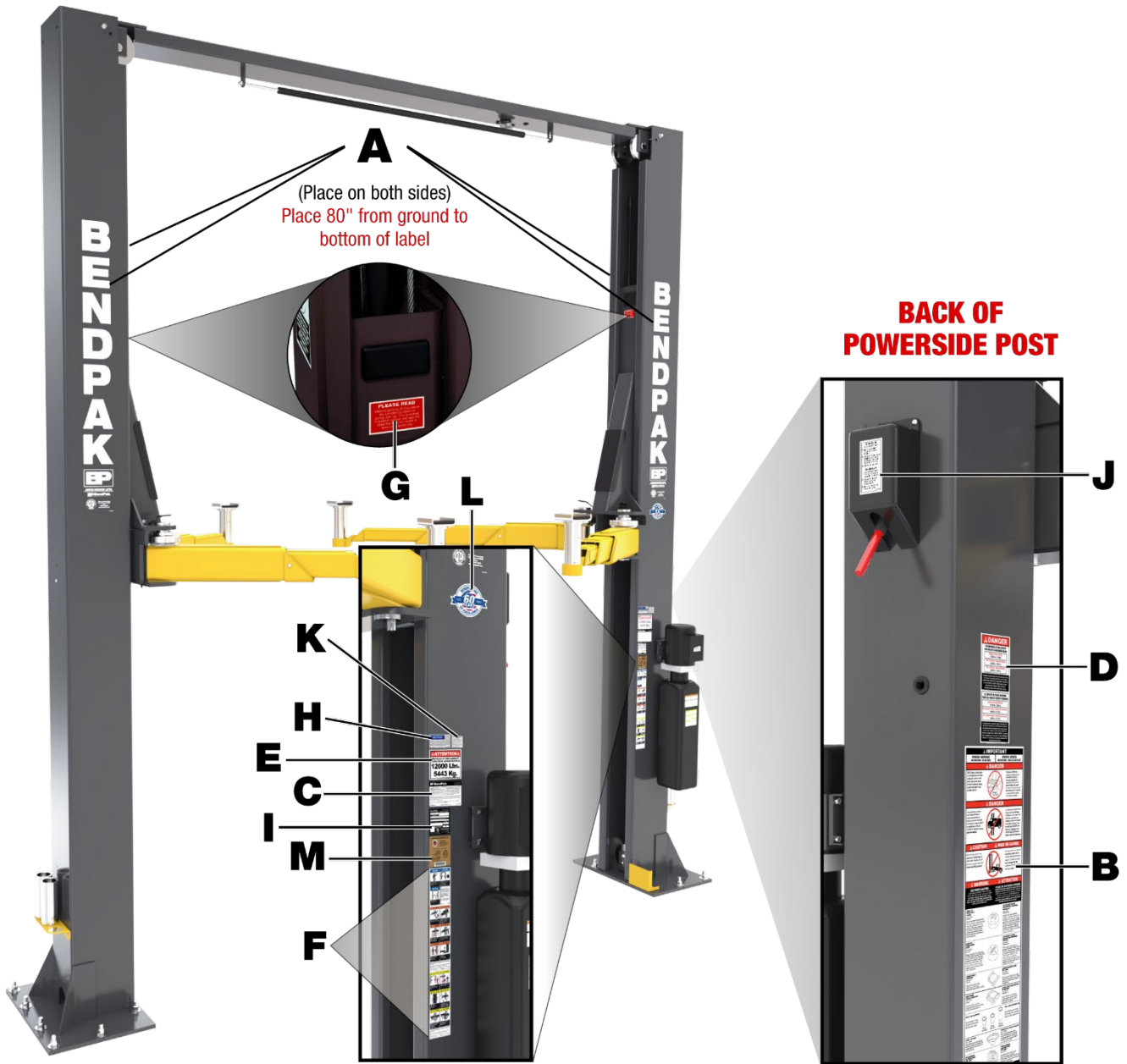

POWERSIDE POST

**ADJACENT TO PU
POWERSIDE POST**

**BACK OF
POWERSIDE POST**

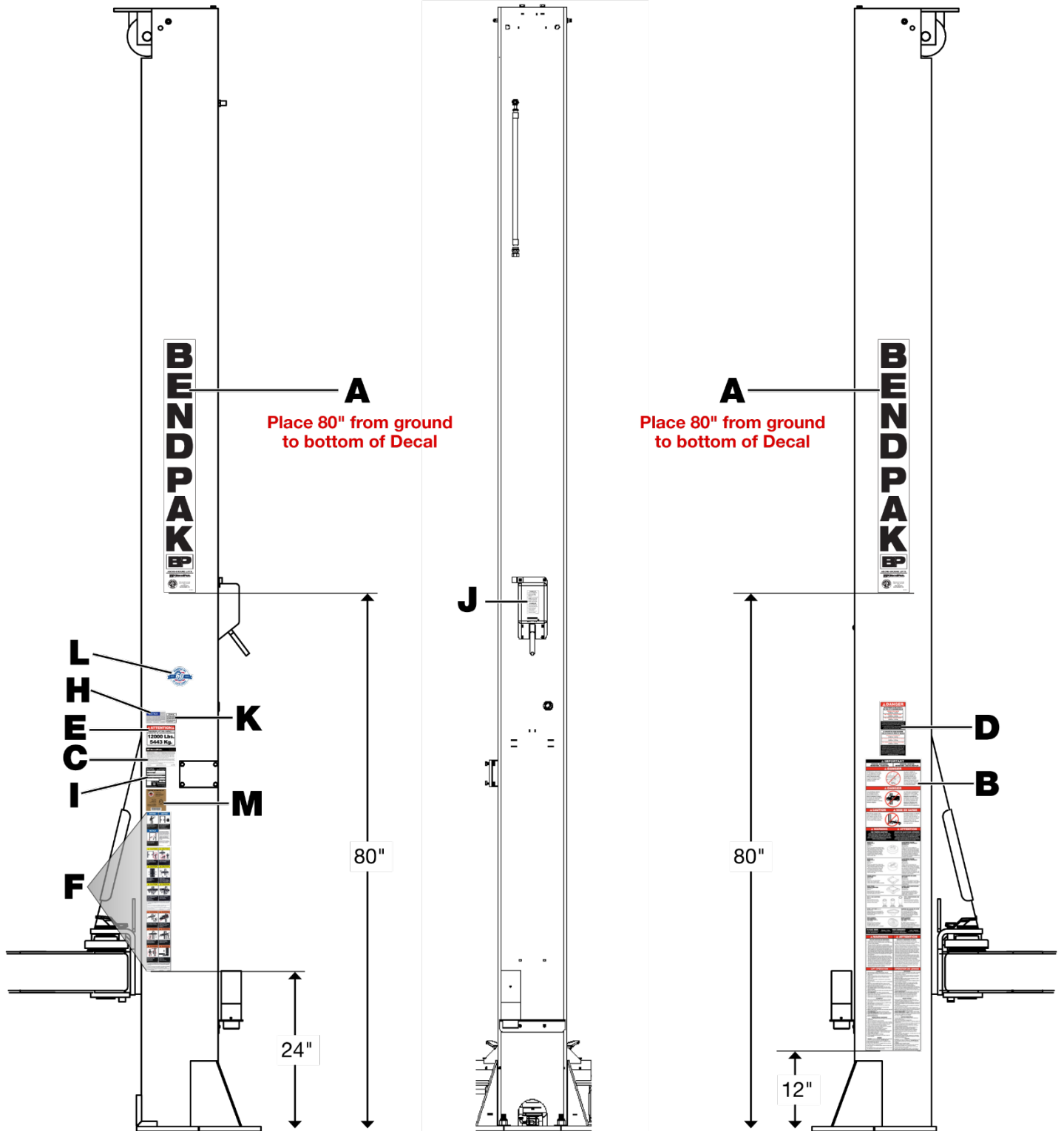

Parts Drawings

Model: 12APX

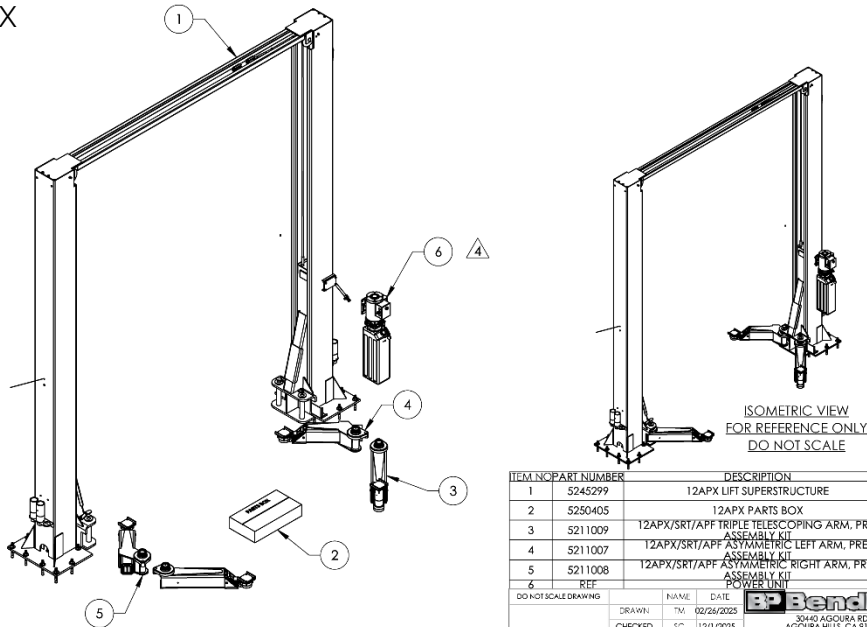

- NOTE: UNLESS OTHERWISE SPECIFIED**
1. REFER TO MODEL FOR ADDITIONAL INFORMATION
 2. SEE COLORS & GRAPHICS FOR LABEL PLACEMENT
 3. SEE SHIPPING INSTRUCTIONS FOR FINAL PACKAGING
- ▲ POWER UNIT REFERENCE ON PURCHASE ORDER

| ITEM NO | PART NUMBER | DESCRIPTION | QTY |
|---------|-------------|--|-----|
| 1 | 5245299 | 12APX LIFT SUPERSTRUCTURE | 1 |
| 2 | 5250405 | 12APX PARTS BOX | 1 |
| 3 | 5211009 | 12APX/SRT/APF TRIPLE TELESCOPING ARM, PRE-ASSEMBLY KIT | 2 |
| 4 | 5211007 | 12APX/SRT/APF ASYMMETRIC LEFT ARM, PRE-ASSEMBLY KIT | 1 |
| 5 | 5211008 | 12APX/SRT/APF ASYMMETRIC RIGHT ARM, PRE-ASSEMBLY KIT | 1 |
| 6 | REF | POWER UNIT | 1 |

| | | | | |
|--|----|------------|------|---|
| DO NOT SCALE DRAWING | | NAME | DATE | BP BendPak 30440 AGOURA RD. AGOURA HILLS, CA 91301 |
| DRAWN | TM | 02/24/2025 | | |
| CHECKED | SC | 12/1/2025 | | TITLE: 12APX PRODUCTION LIFT VER B |
| THIRD ANGLE PROJECTION | | | | SIZE DWG. NO. REV |
| | | | | A 5260730 |
| <small>PROPRIETARY AND CONFIDENTIAL THIS INFORMATION IS THE PROPERTY OF BENDPAK INC. IT IS TO BE KEPT IN STRICTLY CONFIDENTIAL AND NOT TO BE REPRODUCED OR TRANSMITTED IN ANY FORM OR BY ANY MEANS, WITHOUT THE WRITTEN PERMISSION OF BENDPAK INC.</small> | | | | SCALE: 1:35 SHEET 1 OF 3 |

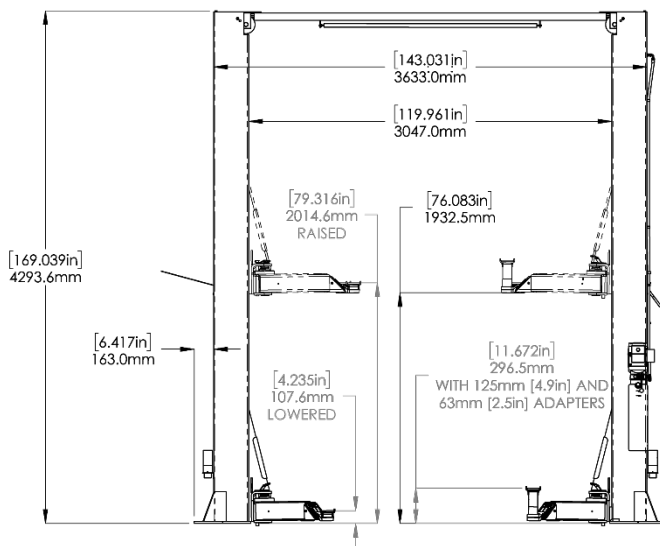
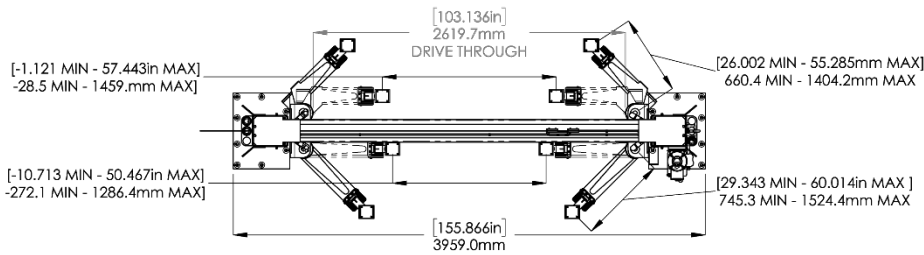

| | |
|---|-----|
| BP BendPak 30440 AGOURA RD. AGOURA HILLS, CA 91301 | |
| TITLE: 12APX PRODUCTION LIFT VER B | |
| SIZE DWG. NO. | REV |
| A 5260730 | |
| SCALE: 1:35 SHEET 2 OF 3 | |

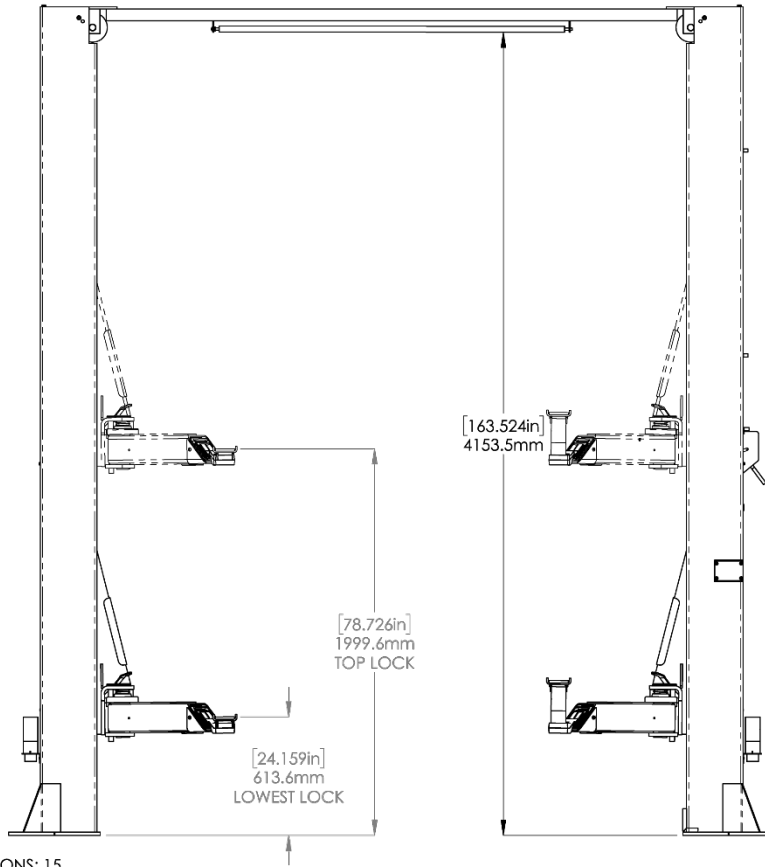

1. SAFETY LOCK POSITIONS: 15
2. SPACED EVERY: 99.0mm / 3.898"

BP BendPak
 30440 AGOURA RD.
 AGOURA HILLS, CA 91301

TITLE: 12APX PRODUCTION LIFT VER B

SIZE (DWG. NO.): A 5260730 REV

SCALE: 1:24 SHEET 3 OF 3

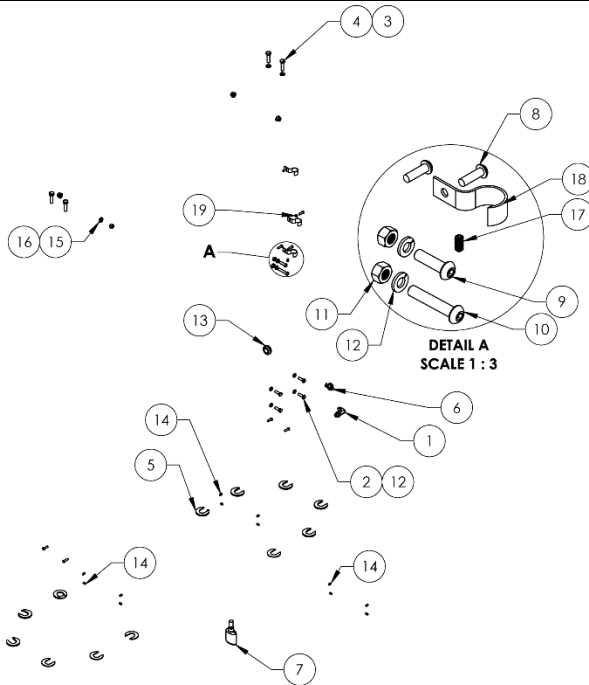

| ITEM NO | PART NUMBER | DESCRIPTION | QTY | REV |
|---------|-------------|---------------------------------|-----|-----|
| 1 | 5550183 | FTG ELB .06 JIC -06L ORB | 1 | - |
| 2 | 5550010 | HHB M8 x 1.25 x 25 FT. CL 10.9 | 4 | - |
| 3 | 5545200 | WASHER M10 x Ø18 SL CL10.9 | 4 | - |
| 4 | 5530302 | HHB M10 x 1.5 x 40 FT. CL 10.9 | 4 | - |
| 5 | 5545535 | C WASHER SHIM FOR LIFTS | 20 | - |
| 6 | 5520140 | ROMEX C.CONNECTOR 3/8 #6623 | 1 | - |
| 7 | 5580012 | LIQUID PTFE THREAD SEALANT 50ml | 1 | - |
| 8 | 5530065 | BHSK M6 x 1.0 x 20 FT. CL 10.9 | 8 | - |
| 9 | 5530412 | BHSK M8 x 1.25 x 30 CL10.9 | 1 | - |
| 10 | 5530413 | BHSK M8 x 1.25 x 45 CL10.9 | 1 | - |
| 11 | 5535001 | NUT M8 x 1.25 NL, CL10.9 | 2 | - |
| 12 | 5545202 | WASHER M8 x Ø15 SL, CL10.9 | 6 | - |
| 13 | 5520001 | RUBBER GROMMET, 3/4 I.D. | 1 | - |
| 14 | 5530551 | SSS M6 x 1.0 x 12 NL CONE | 12 | - |
| 15 | 5545341 | WASHER M10 x Ø20 FLAT, CL10.9 | 4 | - |
| 16 | 5535013 | NUT M10 x 1.5 NL, CL10.9 | 4 | - |
| 17 | 5530460 | SSS M6 x 1.0 x 12 NL FLAT | 1 | - |
| 18 | 5550492 | 3/4" PIPE STRAP | 3 | - |
| 19 | 5545005 | WASHER M6 x 12 FLAT, CL 10.9 | 2 | - |

WHERE USED
12APX SERIES

NOTE: UNLESS OTHERWISE SPECIFIED
 1. REFER TO MODEL FOR ADDITIONAL INFORMATION

NEXT ASSEMBLY
 5250405
 5250406

DO NOT SCALE DRAWINGS

NAME: DATE: 02/26/2025

DRAWN: TM

CHECKED: TM 9/2/2025

THIRD ANGLE PROJECTION

PROPRIETARY AND CONFIDENTIAL
 THE INFORMATION CONTAINED HEREIN IS UNCLASSIFIED EXCEPT WHERE SHOWN OTHERWISE AND IS THE PROPERTY OF BENDPAK INC.

BP BendPak
 30440 AGOURA RD.
 AGOURA HILLS, CA 91301

TITLE: 12APX PARTS BAG

SIZE (DWG. NO.): A 5174156 REV

SCALE: 1:16 SHEET 1 OF 1

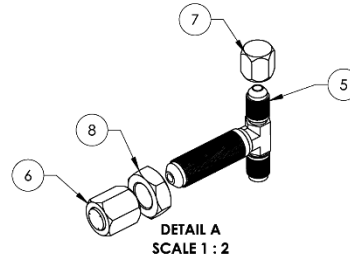
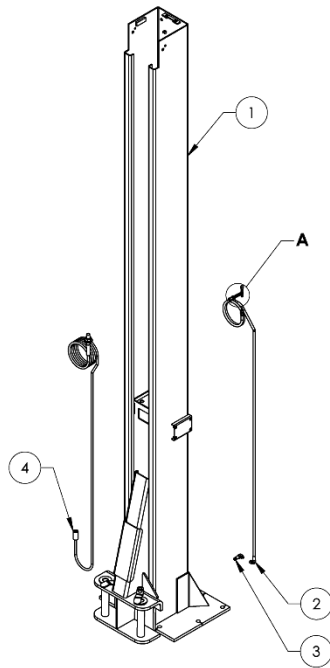
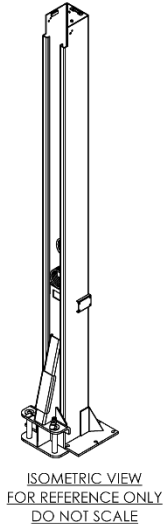

| ITEM NO | PART NUMBER | DESCRIPTION | QTY |
|---------|-------------|--|-----|
| 1 | 5216347 | 12APX POWER SIDE POST ASSEMBLY | 1 |
| 2 | 5570238 | HYDRAULIC HOSE ASSEMBLY Ø6.4 x 3870mm SB | 1 |
| 3 | 5550113 | FTG ELB -04 NPT LL x -04 JIC | 1 |
| 4 | 5595760 | CABLE ASSEMBLY Ø12 x 11660mm ST | 1 |
| 5 | 5550003 | FTG TEE -04JIC x -04JIC x -06JIC | 1 |
| 6 | 5550177 | THREADED FITTING CAP, -06 JIC FEMALE | 1 |
| 7 | 5550054 | THREADED FITTING CAP, -04 JIC FEMALE | 1 |
| 8 | 5535022 | NUT 9/16"-18 JN, Gr 5 | 1 |

WHERE USED
12APX-192

NOTE: UNLESS OTHERWISE SPECIFIED
1. ASSEMBLE ALL ITEMS PRIOR TO PACKAGING

NEXT ASSEMBLY
5245429

DO NOT SCALE DRAWING

| | | | |
|---------|----|------|------------|
| DRAWN | TM | DATE | 05/28/2025 |
| CHECKED | TM | DATE | 9/2/2025 |

BP BendPak
30440 AGOURA RD.
AGOURA HILLS, CA 91301

THIRD ANGLE PROJECTION

TITLE: 12APX-192 POWER SIDE POST, PRE-ASSEMBLY KIT

SIZE DWG. NO. REV
A 5211031

SCALE: 1:25 SHEET 1 OF 2

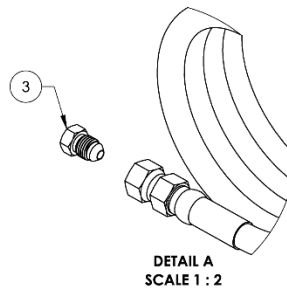
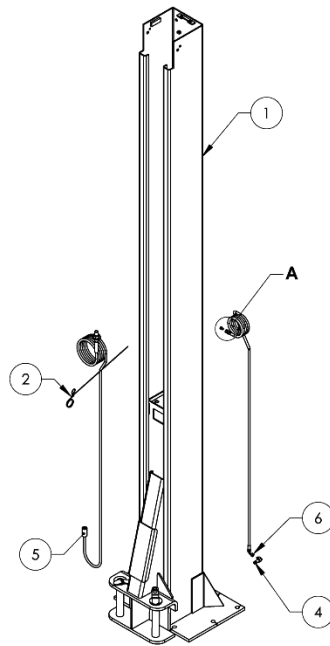
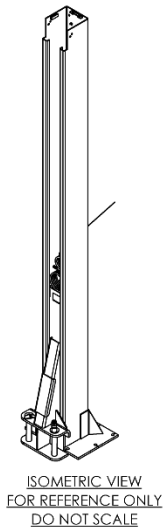

| ITEM NO | PART NUMBER | DESCRIPTION | QTY |
|---------|-------------|---|-----|
| 1 | 5216348 | 12APX OFF SIDE POST ASSEMBLY | 1 |
| 2 | 5595759 | SAFETY CABLE Ø1.8 x 8850mm | 1 |
| 3 | 5550179 | THREADED FITTING PLUG, -04 JIC MALE | 1 |
| 4 | 5550113 | FTG ELB -04 NPT LL x -04 JIC | 1 |
| 5 | 5595758 | CABLE ASSEMBLY Ø12 x 10440mm ST | 1 |
| 6 | 5570254 | HYDRAULIC HOSE ASSEMBLY Ø6.35 x 7950mm SB | 1 |

WHERE USED
12APX

NOTE: UNLESS OTHERWISE SPECIFIED
1. ASSEMBLE ALL ITEMS PRIOR TO PACKAGING

NEXT ASSEMBLY
5245299

DO NOT SCALE DRAWING

| | | | |
|---------|----|------|------------|
| DRAWN | TM | DATE | 05/28/2025 |
| CHECKED | TM | DATE | 9/2/2025 |

BP BendPak
30440 AGOURA RD.
AGOURA HILLS, CA 91301

THIRD ANGLE PROJECTION

TITLE: 12APX OFF SIDE POST, PRE-ASSEMBLY KIT

SIZE DWG. NO. REV
A 5211022

SCALE: 1:25 SHEET 1 OF 2

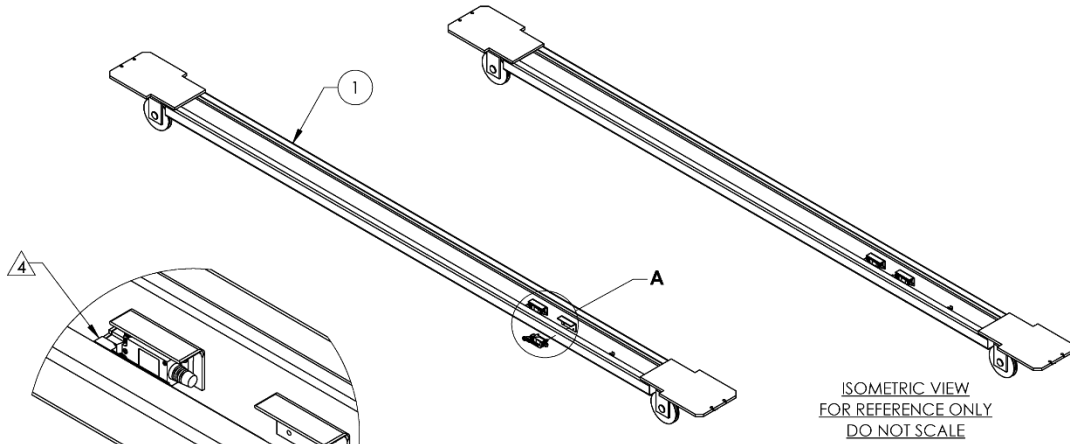

ISOMETRIC VIEW
FOR REFERENCE ONLY
DO NOT SCALE

DETAIL A
SCALE 1 : 4

| WHERE USED |
|------------|
| 12APX |
| 12APX-192 |

- NOTE: UNLESS OTHERWISE SPECIFIED**
1. REFER TO MODEL FOR ADDITIONAL INFORMATION
SEE SHIPPING INSTRUCTIONS FOR FINAL PACKAGING
 2. REFER TO MODEL FOR ADDITIONAL INFORMATION
SEE SHIPPING INSTRUCTIONS FOR FINAL PACKAGING
 3. ASSEMBLE LIMIT SWITCH LEVER ARM TO BE PARALLEL
TO TOP TROUGH CHANNEL
 4. *2nd SWITCH FOR 3 PHASE INSTALLS ONLY

| ITEM NO | PART NUMBER | DESCRIPTION | QTY |
|---------|-------------|---------------------------|-----|
| 1 | 5216349 | 12APX TOP TROUGH ASSEMBLY | 1 |
| 2 | 5520088 | ROCKER LIMIT SWITCH, 25A | 1* |

| | | | |
|----------------------|------------------------|-------------|---|
| DO NOT SCALE DRAWING | NAME | DATE | 30440 AGOURA RD. AGOURA HILLS, CA 91301 |
| | DRAWN | 05/28/2025 | |
| | CHECKED | TM 9/2/2025 | |
| | THIRD ANGLE PROJECTION | | TITLE: 12APX TOP TROUGH, PRE-ASSEMBLY KIT |
| | SIZE DWG. NO. | | A 5211024 |
| | REV | | |

| | |
|---------------|---------|
| NEXT ASSEMBLY | 5245299 |
| | 5245429 |

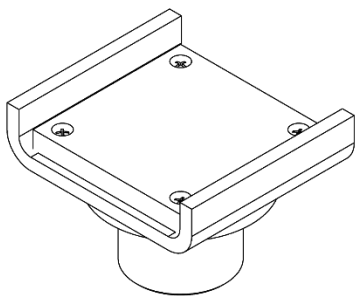

ISOMETRIC VIEW
FOR REFERENCE ONLY
DO NOT SCALE

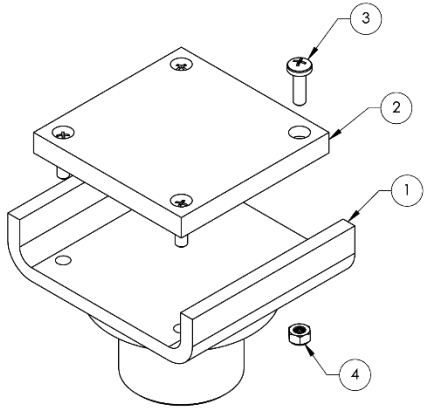

| WHERE USED |
|-----------------------------------|
| 12APF |
| 12AP-SRT |
| 12APX SERIES |
| EV12DPS |
| 16AP SERIES |
| 20AP SERIES |
| D2-12C* |
| D2-15C* |
| XPR-12 SERIES* |
| XPR-15 SERIES* |
| XPR-18 SERIES* |
| *ARMS WITH Ø60mm ARM ADAPTER HOLE |

- NOTE: UNLESS OTHERWISE SPECIFIED**
1. REFER TO MODEL FOR ADDITIONAL INFORMATION
SEE SHIPPING INSTRUCTIONS FOR FINAL PACKAGING
 2. REFER TO MODEL FOR ADDITIONAL INFORMATION
SEE SHIPPING INSTRUCTIONS FOR FINAL PACKAGING
 3. ASSEMBLE ITEMS AS SHOWN

| ITEM NO | PART NUMBER | DESCRIPTION | QTY |
|---------|-------------|---|-----|
| 1 | 5601000 | FRAME CRADLE LIFT PAD ADAPTER WELDMENT, Ø60mm | 1 |
| 2 | 5715020 | FRAME CRADLE LIFT PAD ADAPTER POLYURETHANE PAD, Ø60mm | 1 |
| 3 | 5530022 | PHPS M6 x 1 x 20mm ZPL | 4 |
| 4 | 5535357 | NUT M6 x 1.0 NL | 4 |

| | | | |
|----------------------|------------------------|------------|--|
| DO NOT SCALE DRAWING | NAME | DATE | 1645 LEMMONWOOD DR SANTA FE, CA 90860 |
| | DRAWN | 06/24/2015 | |
| | CHECKED | | |
| | THIRD ANGLE PROJECTION | | TITLE: FRAME CRADLE LIFT PAD ADAPTER ASSEMBLY, Ø60mm |
| | SIZE DWG. NO. | | A 5215702 |
| | REV | | |

| | |
|---------------|---------|
| NEXT ASSEMBLY | 5215761 |
| | 5250396 |
| | 5250400 |
| | 5250405 |
| | 5250406 |
| | 5250412 |
| | 5250414 |

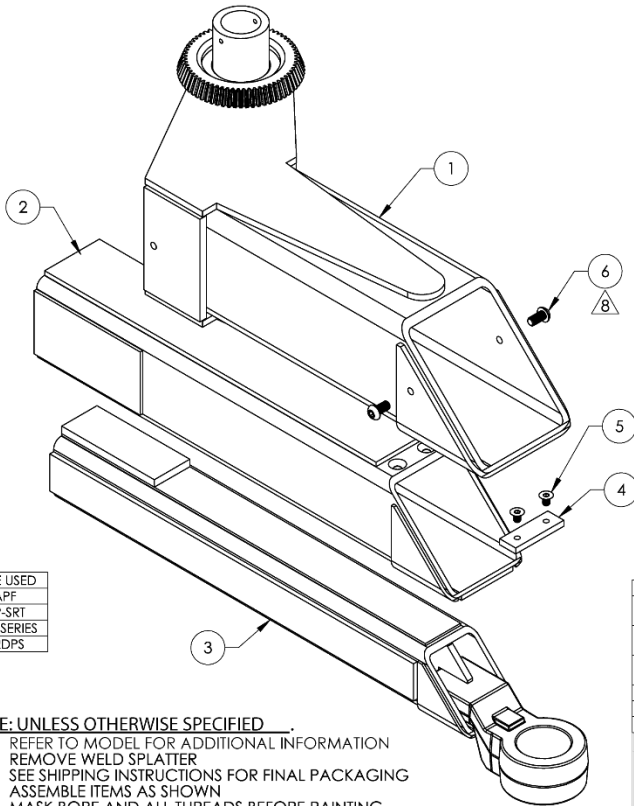

| WHERE USED |
|--------------|
| 12APF |
| 12AP-SRT |
| 12APX SERIES |
| EV12DPS |

NOTE: UNLESS OTHERWISE SPECIFIED...

1. REFER TO MODEL FOR ADDITIONAL INFORMATION
2. REMOVE WELD SPLATTER
3. SEE SHIPPING INSTRUCTIONS FOR FINAL PACKAGING
4. ASSEMBLE ITEMS AS SHOWN
5. MASK BORE AND ALL THREADS BEFORE PAINTING
6. DIMENSIONS SHOWN ARE AFTER WELDING AND PAINTING
7. PAINT YELLOW (RAL-1018) 20% GLOSS
8. APPLY LOCTITE BLUE 242 AND CURE PER MANUFACTURE SPECIFICATION

| NEXT ASSEMBLY |
|---------------|
| 5211007 |
| 5260738 |

| ITEM NO. | PART NUMBER | DESCRIPTION | QTY. |
|----------|-------------|--|------|
| 1 | 5601899 | 12APX/SRT/APF ASYMMETRIC ARM WELDMENT, OUTER LEFT TUBE | 1 |
| 2 | 5601898 | 12APX/SRT/APF ASYMMETRIC ARM WELDMENT, MIDDLE TUBE | 1 |
| 3 | 5601897 | 12APX/SRT/APF ASYMMETRIC ARM WELDMENT, INNER TUBE | 1 |
| 4 | 5737188 | AP MIDDLE ARM SLIDE STOP | 1 |
| 5 | 5530382 | FHSS M8 x 1.25 x 12 CL10.9 | 2 |
| 6 | 5530479 | BHSS M10 x 1.5 x 20 FT. CL 10.9 B.O. | 2 |

DO NOT SCALE DRAWING

DRAWN: RK
 CHECKED: RK
 NAME: RK
 DATE: 07/22/2022

BendPak
 1645 LEMONWOOD DR.
 SANTA PAULA, CA 93060

DIMENSIONS ARE IN MM

THIRD ANGLE PROJECTION

TITLE: 12APX/SRT/APF TRIPLE TELESCOPING ASYMMETRIC ARM ASSEMBLY, LEFT



SIZE DWG. NO. A 5216197

SCALE: 1:5 SHEET 1 OF 2

PROPRIETARY AND CONFIDENTIAL
 THE INFORMATION CONTAINED IN THIS DRAWING IS THE SOLE PROPERTY OF BENDPAK INC. REPRODUCTION IN PART OR AS A WHOLE WITHOUT THE WRITTEN PERMISSION OF BENDPAK INC. IS PROHIBITED.

SCALE: 1:5 SHEET 1 OF 2

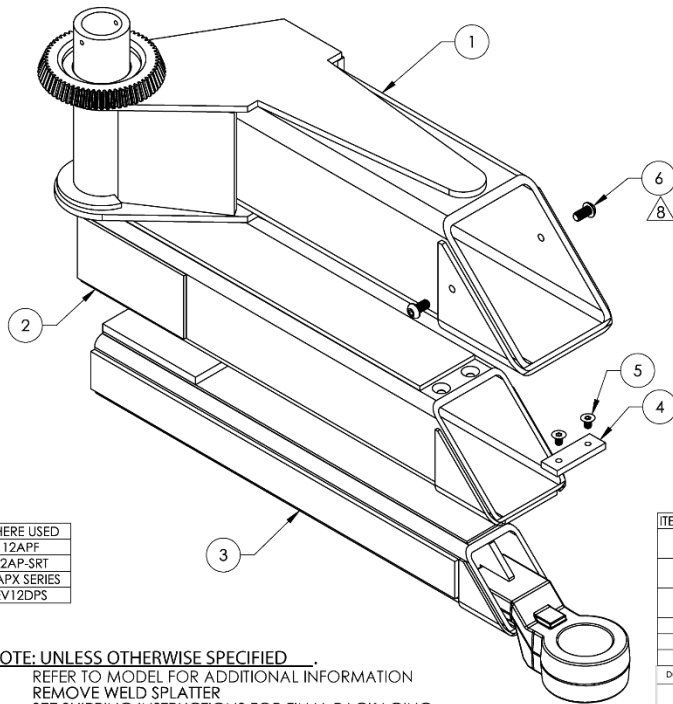
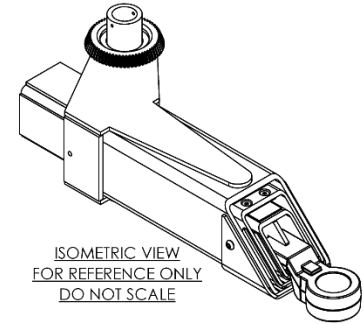

| WHERE USED |
|--------------|
| 12APF |
| 12AP-SRT |
| 12APX SERIES |
| EV12DPS |

NOTE: UNLESS OTHERWISE SPECIFIED...

1. REFER TO MODEL FOR ADDITIONAL INFORMATION
2. REMOVE WELD SPLATTER
3. SEE SHIPPING INSTRUCTIONS FOR FINAL PACKAGING
4. ASSEMBLE ITEMS AS SHOWN
5. MASK BORE AND ALL THREADS BEFORE PAINTING
6. DIMENSIONS SHOWN ARE AFTER WELDING AND PAINTING
7. PAINT YELLOW (RAL-1018) 20% GLOSS
8. APPLY LOCTITE BLUE 242 AND CURE PER MANUFACTURE SPECIFICATION

| NEXT ASSEMBLY |
|---------------|
| 5211008 |
| 5260738 |

| ITEM NO. | PART NUMBER | DESCRIPTION | QTY. |
|----------|-------------|---|------|
| 1 | 5601900 | 12APX/SRT/APF ASYMMETRIC ARM WELDMENT, OUTER RIGHT TUBE | 1 |
| 2 | 5601898 | 12APX/SRT/APF ASYMMETRIC ARM WELDMENT, MIDDLE TUBE | 1 |
| 3 | 5601897 | 12APX/SRT/APF ASYMMETRIC ARM WELDMENT, INNER TUBE | 1 |
| 4 | 5737188 | AP MIDDLE ARM SLIDE STOP | 1 |
| 5 | 5530382 | FHSS M8 x 1.25 x 12 CL10.9 | 2 |
| 6 | 5530479 | BHSS M10 x 1.5 x 20 FT. CL 10.9 B.O. | 2 |

DO NOT SCALE DRAWING

DRAWN: RK
 CHECKED: RK
 NAME: RK
 DATE: 07/22/2022

BendPak
 1645 LEMONWOOD DR.
 SANTA PAULA, CA 93060

DIMENSIONS ARE IN MM

THIRD ANGLE PROJECTION

TITLE: 12APX/SRT/APF TRIPLE TELESCOPING ASYMMETRIC ARM ASSEMBLY, RIGHT



SIZE DWG. NO. A 5216198

SCALE: 1:5 SHEET 1 OF 2

PROPRIETARY AND CONFIDENTIAL
 THE INFORMATION CONTAINED IN THIS DRAWING IS THE SOLE PROPERTY OF BENDPAK INC. REPRODUCTION IN PART OR AS A WHOLE WITHOUT THE WRITTEN PERMISSION OF BENDPAK INC. IS PROHIBITED.

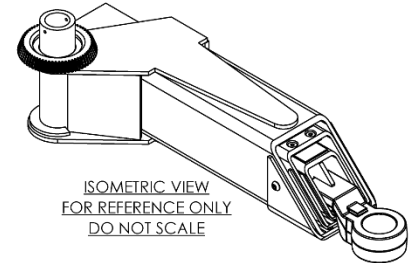

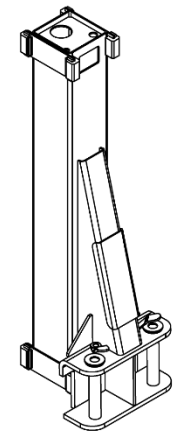

ISOMETRIC VIEW
FOR REFERENCE ONLY
DO NOT SCALE

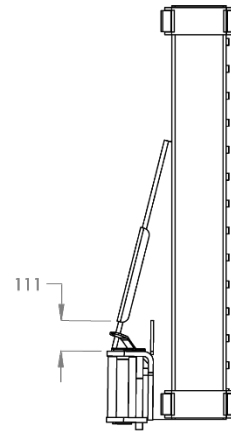
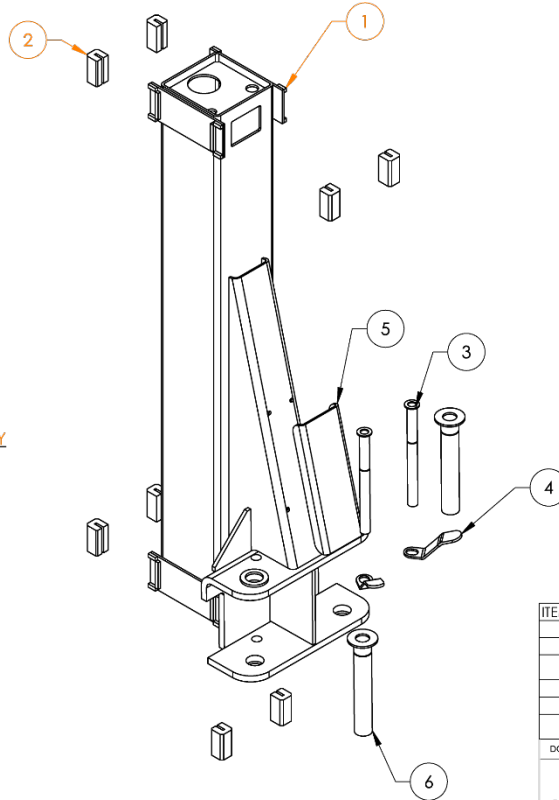

| |
|------------|
| WHERE USED |
| 12APX |
| 12APX-192 |

NOTE: UNLESS OTHERWISE SPECIFIED

1. REFER TO MODEL FOR ADDITIONAL INFORMATION
2. SEE SHIPPING INSTRUCTIONS FOR FINAL PACKAGING
3. ASSEMBLE ITEMS AS SHOWN

| |
|---------------|
| NEXT ASSEMBLY |
| 5216347 |
| 5216348 |

| ITEM NO | PART NUMBER | DESCRIPTION | QTY |
|---------|-------------|---|-----|
| 1 | 5601903 | 12APX LIFT HEAD WELDMENT | 1 |
| 2 | 5716001 | 2 POST GUIDE BLOCK | 8 |
| 3 | 5602030 | 12APX/SRT/APF ARM LOCK GROOVE WELDMENT, Ø25mm, GROOVE | 2 |
| 4 | 5701700 | APF ARM LOCK RELEASE HANDLE | 2 |
| 5 | 5930004 | 12/1&1/20AP LIFT HEAD GUSSET COVER | 1 |
| 6 | 5601910 | 12APX/SRT/APF ARM LOCK PIN WELDMENT, Ø44mm | 2 |

| | | | |
|----------------------|----------|------------|---|
| DO NOT SCALE DRAWING | NAME | DATE | 1645 LEMONWOOD DR. SANTA PAULA, CA 93060 |
| | DRAWN RK | 03/31/2022 | |
| | CHECKED | | TITLE: 12APX LIFT HEAD ASSEMBLY |
| | | | SIZE DWG. NO. REV |
| | | | A 5216201 |
| | | | SCALE: 1:12 SHEET 1 OF 2 |

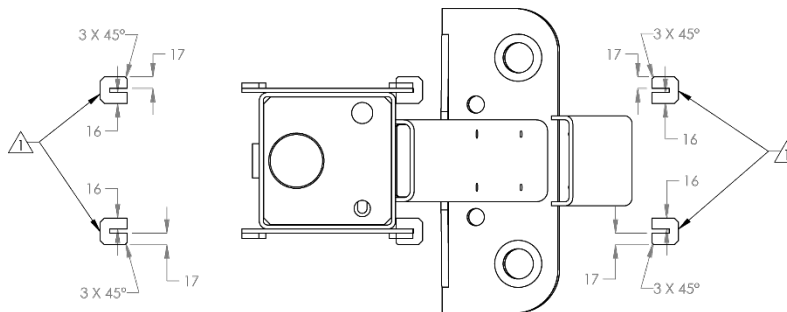

TOP VIEW

NOTE: UNLESS OTHERWISE SPECIFIED

1. NOTE ORIENTATION OF PLASTIC GUIDE BLOCK

| | |
|---|--------------------------|
| 1645 LEMONWOOD DR. SANTA PAULA, CA 93060 | |
| TITLE: | 12APX LIFT HEAD ASSEMBLY |
| SIZE DWG. NO. REV | A 5216201 |
| SCALE: | 1:10 SHEET 2 OF 2 |

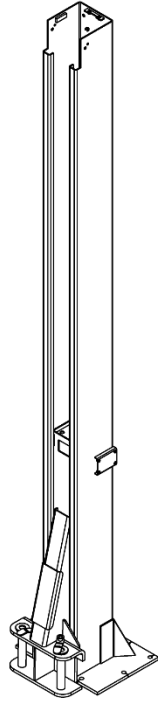

| WHERE USED |
|------------|
| 12APX |
| 12APX-192 |

NOTE: UNLESS OTHERWISE SPECIFIED

1. REFER TO MODEL FOR ADDITIONAL INFORMATION
2. SEE SHIPPING INSTRUCTIONS FOR FINAL PACKAGING
3. ASSEMBLE ITEMS AS SHOWN

| ITEM NO | PART NUMBER | DESCRIPTION | QTY |
|---------|-------------|---|-----|
| 1 | 5602137 | 12APX POWER SIDE POST WELDMENT | 1 |
| 2 | 5216201 | 12APX LIFT HEAD ASSEMBLY | 1 |
| 3 | 5502057 | CYLINDER ASSEMBLY Ø2.5 x 75 | 1 |
| 4 | 5701115 | CYLINDER CLAMP ASSY-74-79 | 1 |
| 5 | 5575113 | 12/16/20AP SHEAVE ASSEMBLY, Ø152mm | 1 |
| 6 | 5620142 | 12/16/20AP CABLE SHEAVE PIN WELDMENT, Ø35mm | 1 |
| 7 | 5530181 | HHB M6 x 1.0 x 10 FT, CL 10.9 | 1 |
| 8 | 5575074 | AP SAFETY CABLE ROLLER | 1 |
| 9 | 5530756 | HHB M6 x 1.0 x 25 FT, CL 10.9 | 1 |
| 10 | 5535357 | NUT M6 x 1.0 NL, CL 10.9 | 1 |
| 11 | 5565350 | SAFETY SHEAVE SPACER, 11.5mm | 1 |
| 12 | 5601905 | 12/16/20AP POWER SIDE SAFETY WELDMENT | 1 |
| 13 | 5746494 | AP SAFETY PIVOT PIN | 1 |
| 14 | 5530414 | BHSK M8 x 1.25 x 25 CL10.9 | 1 |
| 15 | 5545202 | WASHER M8 x Ø15 SL, CL10.9 | 1 |
| 16 | 5540047 | EXTENSION SPRING Ø6.35 x 38mm | 2 |
| 17 | 5530045 | BHPS M5 x 0.8 x 10 FT, CL 8.8 | 4 |
| 18 | 5535057 | NUT M8 x 1.25 x 17.5, RIVET | 4 |
| 19 | 5535058 | NUT M6 x 1.0 x 18, RIVET | 8 |
| 20 | 5535059 | NUT M10 x 1.5 x 20.5, RIVET | 2 |

DO NOT SCALE DRAWING

DIMENSIONS ARE IN MM

THIRD ANGLE PROJECTION

BP BendPak
30440 AGOURA RD.
AGOURA HILLS, CA 91301

TITLE: 12APX POWER SIDE POST ASSEMBLY

SIZE DWG. NO. A 5216347 REV

SCALE: 1:25 SHEET 1 OF 2

PROPRIETARY AND CONFIDENTIAL
THE INFORMATION CONTAINED HEREIN IS THE PROPERTY OF BENDPAK INC. ANY
REPRODUCTION OR TRANSMISSION IN ANY FORM OR BY ANY MEANS WITHOUT
THE WRITTEN PERMISSION OF BENDPAK INC. IS
PROHIBITED.

| NEXT ASSEMBLY |
|---------------|
| 5211021 |
| 5211031 |

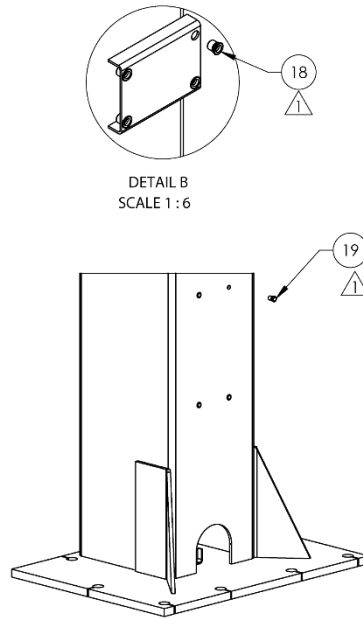
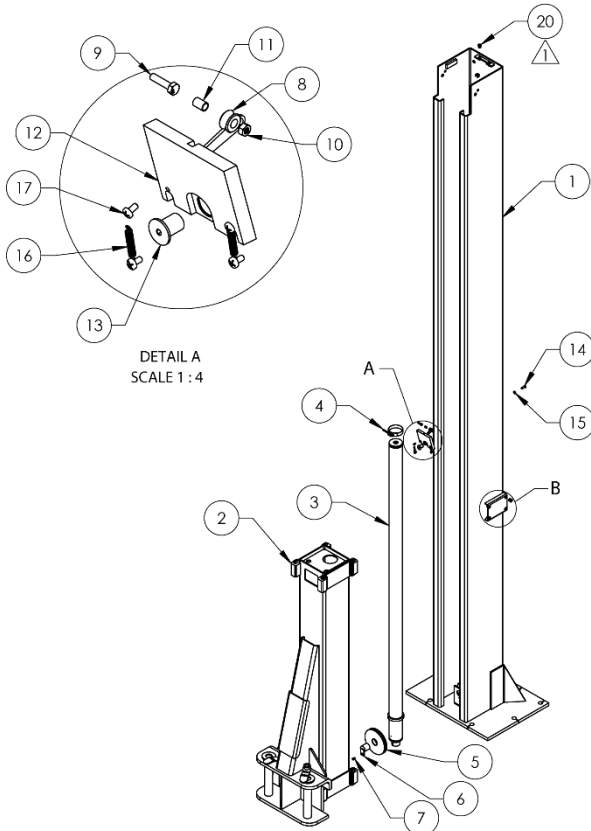

INSTALL RIVET NUTS INTO POST AND POST BRACKET

BP BendPak
30440 AGOURA RD.
AGOURA HILLS, CA 91301

TITLE: 12APX POWER SIDE POST ASSEMBLY

SIZE DWG. NO. A 5216347 REV

SCALE: 1:25 SHEET 2 OF 2

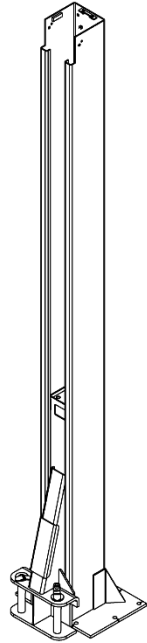

| WHERE USED |
|------------|
| 12APX |
| 12APX-192 |

NOTE: UNLESS OTHERWISE SPECIFIED

1. REFER TO MODEL FOR ADDITIONAL INFORMATION
2. SEE SHIPPING INSTRUCTIONS FOR FINAL PACKAGING
3. ASSEMBLE ITEMS AS SHOWN

NEXT ASSEMBLY
5211032

| ITEM NO | PART NUMBER | DESCRIPTION | QTY |
|---------|-------------|---|-----|
| 1 | 5602138 | 12APX OFF SIDE POST WELDMENT | 1 |
| 2 | 5216201 | 12APX LIFT HEAD ASSEMBLY | 1 |
| 3 | 5502057 | CYLINDER ASSEMBLY Ø2.5 x 75 | 1 |
| 4 | 5701115 | CYLINDER CLAMP ASSY-74-79 | 1 |
| 5 | 5575113 | 12/16/20AP SHEAVE ASSEMBLY, Ø152mm | 1 |
| 6 | 5620142 | 12/16/20AP CABLE SHEAVE PIN WELDMENT, Ø35mm | 1 |
| 7 | 5530181 | HHB M6 x 1.0 x 10 FT, CL 10.9 | 1 |
| 8 | 5575074 | AP SAFETY CABLE ROLLER | 1 |
| 9 | 5530756 | HHB M6 x 1.0 x 25 FT, CL 10.9 | 1 |
| 10 | 5535357 | NUT M6 x 1.0 NI, CL10.9 | 1 |
| 11 | 5565350 | SAFETY SHEAVE SPACER, 11.5mm | 1 |
| 12 | 5737354 | 12APX OFF SIDE SAFETY BLOCK | 1 |
| 13 | 5746494 | AP SAFETY PIVOT PIN | 1 |
| 14 | 5530414 | BHSC M8 x 1.25 x 25 CL10.9 | 1 |
| 15 | 5545202 | WASHER M8 x Ø15 SL, CL10.9 | 1 |
| 16 | 5540047 | EXTENSION SPRING Ø6.35 x 38mm | 2 |
| 17 | 5530045 | BHPS M5 x 0.8 x 10 FT, CL 8.8 | 4 |
| 18 | 5535058 | NUT M6 x 1.0 x 18, RIVET | 4 |
| 19 | 5535059 | NUT M10 x 1.5 x 20.5, RIVET | 2 |

DO NOT SCALE DRAWINGS

| | | |
|-------|------|------------|
| DRAWN | NAME | DATE |
| TM | | 02/26/2025 |

CHECKED

THIRD ANGLE PROJECTION

BP BendPak
30440 AGOURA RD.
AGOURA HILLS, CA 91301

TITLE: 12APX OFF SIDE POST ASSEMBLY

SIZE DWG. NO. REV

A 5216348

SCALE: 1:25 SHEET 1 OF 2

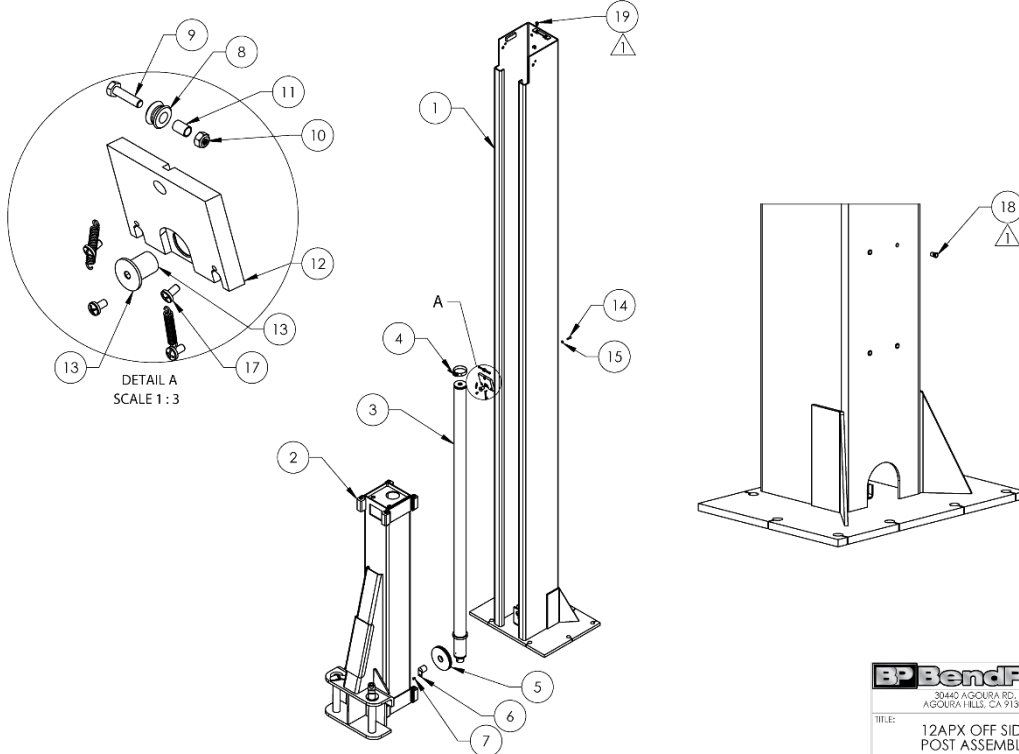

▲ INSTALL RIVET NUTS INTO POST

BP BendPak
30440 AGOURA RD.
AGOURA HILLS, CA 91301

TITLE: 12APX OFF SIDE POST ASSEMBLY

SIZE DWG. NO. REV

A 5216348

SCALE: 1:25 SHEET 2 OF 2

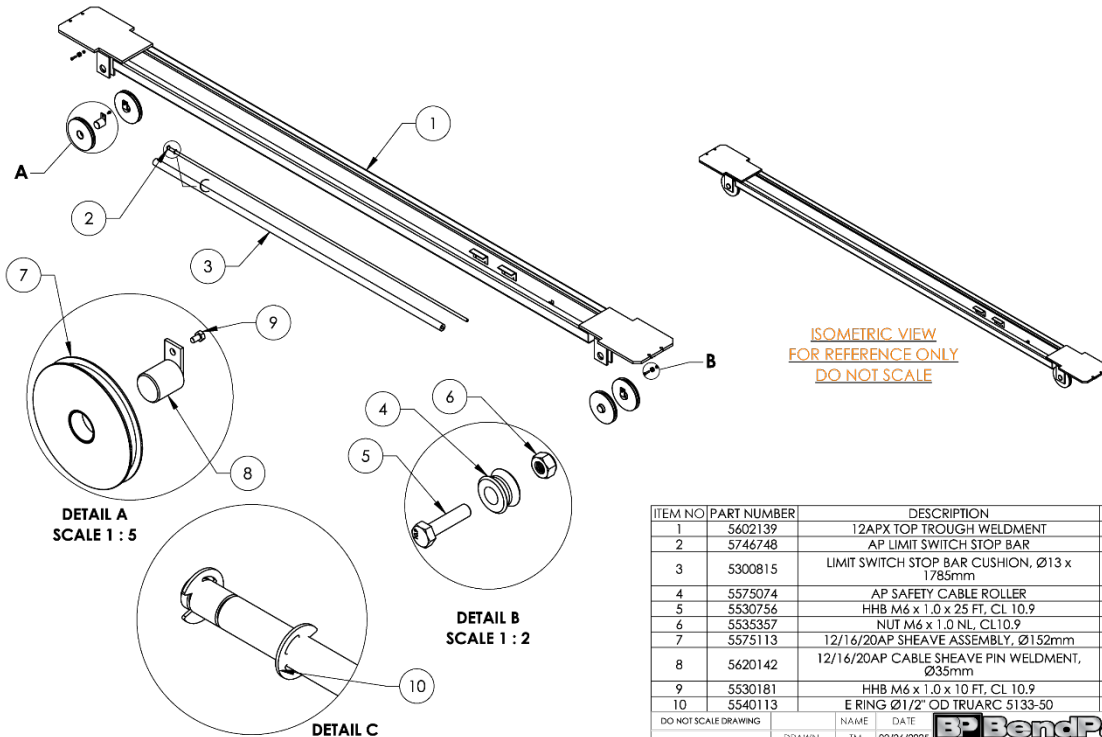

ISOMETRIC VIEW
FOR REFERENCE ONLY
DO NOT SCALE

DETAIL A
SCALE 1 : 5

DETAIL B
SCALE 1 : 2

DETAIL C
SCALE 2 : 3

| |
|------------|
| WHERE USED |
| 12APX |
| 12APX-192 |

NOTE: UNLESS OTHERWISE SPECIFIED

1. REFER TO MODEL FOR ADDITIONAL INFORMATION
2. SEE SHIPPING INSTRUCTIONS FOR FINAL PACKAGING
3. ASSEMBLE ITEMS AS SHOWN

NEXT ASSEMBLY
5211024

| ITEM NO | PART NUMBER | DESCRIPTION | QTY |
|---------|-------------|---|-----|
| 1 | 5602139 | 12APX TOP TROUGH WELDMENT | 1 |
| 2 | 5746748 | AP LIMIT SWITCH STOP BAR | 1 |
| 3 | 5300815 | LIMIT SWITCH STOP BAR CUSHION, Ø13 x 1785mm | 1 |
| 4 | 5575074 | AP SAFETY CABLE ROLLER | 2 |
| 5 | 5530756 | HHB M6 x 1.0 x 25 FT, CL 10.9 | 2 |
| 6 | 5535357 | NUT M6 x 1.0 NL, CL10.9 | 2 |
| 7 | 5575113 | 12/16/20AP SHEAVE ASSEMBLY, Ø152mm | 4 |
| 8 | 5620142 | 12/16/20AP CABLE SHEAVE PIN WELDMENT, Ø35mm | 4 |
| 9 | 5530181 | HHB M6 x 1.0 x 10 FT, CL 10.9 | 4 |
| 10 | 5540113 | E RING Ø1/2" OD TRUARC 5133-50 | 2 |

DO NOT SCALE DRAWING

DRAWN: TM 02/24/2025
CHECKED: TM 9/2/2025

NAME: **BP BendPak**
DATE: 30440 AGOURA RD, AGOURA HILLS, CA 91301

THIRD ANGLE PROJECTION

TITLE: 12APX TOP TROUGH ASSEMBLY

SCALE: 1:20

SIZE DWG. NO. A 5216349

REV

PROPRIETARY AND CONFIDENTIAL. THE INFORMATION CONTAINED IN THIS DRAWING IS THE SOLE PROPERTY OF BENDPAK INC. REPRODUCTION IN PART OR AS A WHOLE WITHOUT THE WRITTEN PERMISSION OF BENDPAK INC. IS PROHIBITED.

SCALE: 1:20 SHEET 1 OF 2

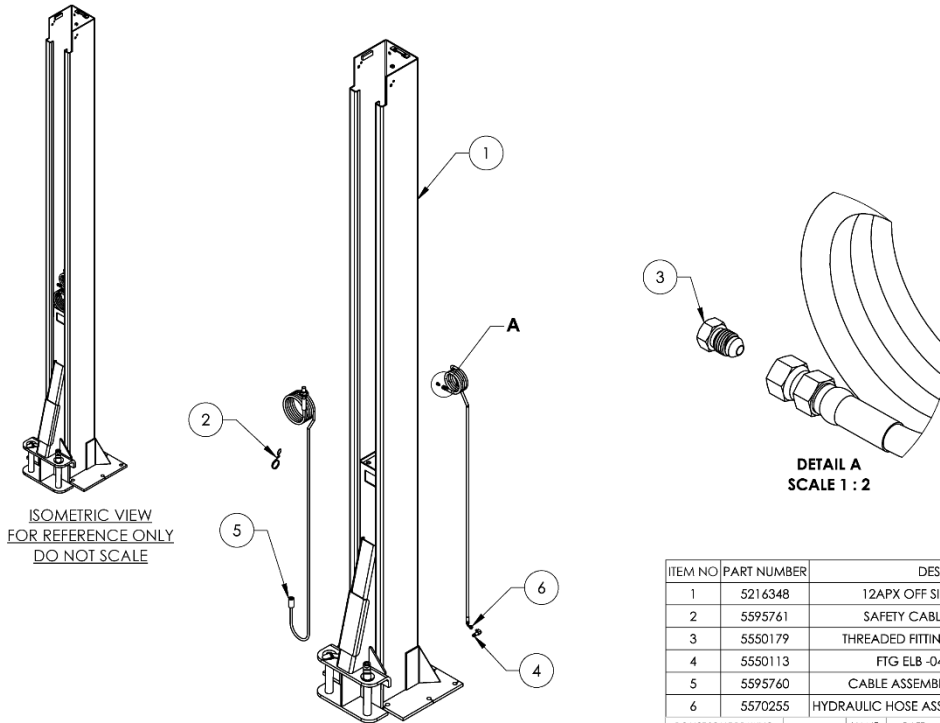

ISOMETRIC VIEW
FOR REFERENCE ONLY
DO NOT SCALE

DETAIL A
SCALE 1 : 2

| |
|------------|
| WHERE USED |
| 12APX-192 |

NOTE: UNLESS OTHERWISE SPECIFIED

1. ASSEMBLE ALL ITEMS PRIOR TO PACKAGING

NEXT ASSEMBLY
5245429

| ITEM NO | PART NUMBER | DESCRIPTION | QTY |
|---------|-------------|---|-----|
| 1 | 5216348 | 12APX OFF SIDE POST ASSEMBLY | 1 |
| 2 | 5595761 | SAFETY CABLE Ø1.8 x 10070mm | 1 |
| 3 | 5550179 | THREADED FITTING PLUG, -04 JIC MALE | 1 |
| 4 | 5550113 | FTG ELB -04 NPT LL x -04 JIC | 1 |
| 5 | 5595760 | CABLE ASSEMBLY Ø12 x 11660mm ST | 1 |
| 6 | 5570255 | HYDRAULIC HOSE ASSEMBLY Ø6.35 x 9168mm SB | 1 |

DO NOT SCALE DRAWING

DRAWN: TM 05/28/2025
CHECKED: TM 9/2/2025

NAME: **BP BendPak**
DATE: 30440 AGOURA RD, AGOURA HILLS, CA 91301

THIRD ANGLE PROJECTION

TITLE: 12APX-192 OFF SIDE POST, PRE-ASSEMBLY KIT

SCALE: 1:25

SIZE DWG. NO. A 5211032

REV

PROPRIETARY AND CONFIDENTIAL. THE INFORMATION CONTAINED IN THIS DRAWING IS THE SOLE PROPERTY OF BENDPAK INC. REPRODUCTION IN PART OR AS A WHOLE WITHOUT THE WRITTEN PERMISSION OF BENDPAK INC. IS PROHIBITED.

SCALE: 1:25 SHEET 1 OF 2

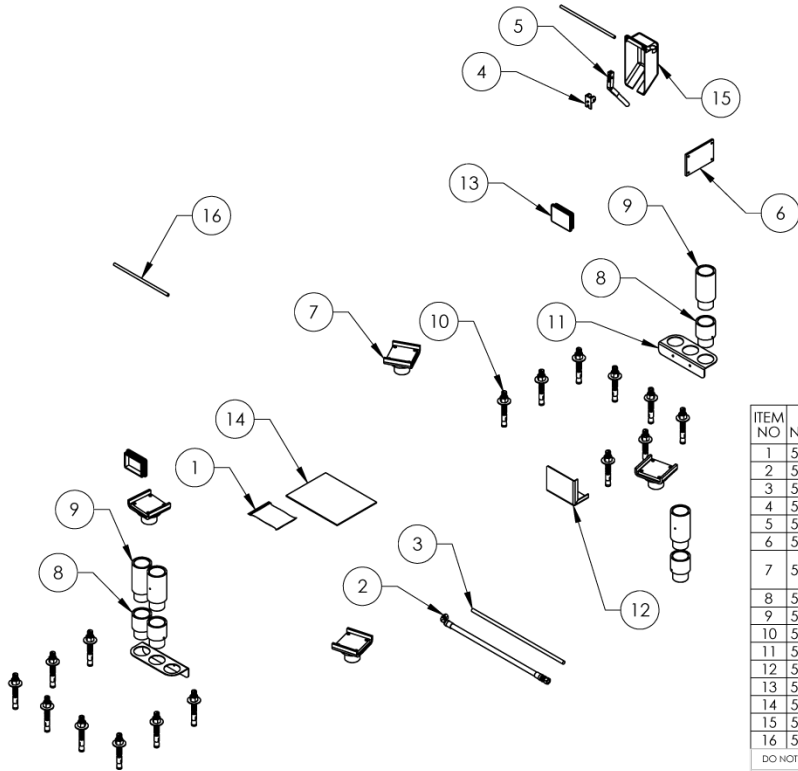

WHERE USED
12APX

NOTE: UNLESS OTHERWISE SPECIFIED

1. REFER TO MODEL FOR ADDITIONAL INFORMATION
2. INSERT PARTS BAG INTO PARTS BOX FOR SHIPMENT
3. HOSES AND CABLES SHOWN REPRESENTATIONAL FORM

NEXT ASSEMBLY
5260730

| ITEM NO | PART NUMBER | DESCRIPTION | QTY |
|---------|-------------|---|--------|
| 1 | 5174156 | 12APX PARTS BAG | 1 |
| 2 | 5570290 | HYDRAULIC HOSE ASSEMBLY Ø10 x 2790mm SB | 1 |
| 3 | 5520032 | CABLE, AWG 14-2, SOOW | 4320mm |
| 4 | 5700404 | AP SAFETY PIVOT HOLDER | 1 |
| 5 | 5761017 | AP SAFETY HANDLE | 1 |
| 6 | 5715003 | POWER UNIT VIBRATION DAMPENERS | 1 |
| 7 | 5215702 | FRAME CRADLE LIFT PAD ADAPTER ASSEMBLY, Ø60mm | 4 |
| 8 | 5746192 | ARM ADAPTER, MEDIUM | 4 |
| 9 | 5746193 | ARM ADAPTER, LONG | 4 |
| 10 | 5530337 | AB 3/4" x 6.3" | 16 |
| 11 | 5701660 | HEIGHT ADAPTER HOLDER, 60mm | 2 |
| 12 | 5701901 | 12APX FOOT GUARD | 1 |
| 13 | 5715196 | POLYETHYLENE COVER BLOCK 105 x 80 | 2 |
| 14 | 5900374 | 12APX INSTALLATION MANUAL | 1 |
| 15 | 5716072 | AP POWER SIDE PLASTIC SAFETY COVER | 1 |
| 16 | 5746166 | DOUBLE THREADED ROD M10 x 1.5 x 295 | 2 |

| | | | | |
|----------------------|----|---|--------------|--|
| DO NOT SCALE DRAWING | | NAME | DATE | BendPak 30440 AGOURA RD, AGOURA HILLS, CA 91301 |
| DRAWN | TM | 02/26/2025 | | |
| CHECKED | TM | 9/2/2025 | | |
| DIMENSIONS ARE IN MM | | THIRD ANGLE PROJECTION | | TITLE: 12APX PARTS BOX |
| | | <small>PROPRIETARY AND CONFIDENTIAL THE INFORMATION CONTAINED IN THIS DRAWING IS THE SOLE PROPERTY OF BENDPAK, INC. ANY REPRODUCTION IN PART OR AS A WHOLE WITHOUT THE WRITTEN PERMISSION OF BENDPAK, INC. IS PROHIBITED.</small> | | SIZE DWG. NO. REV |
| | | A 5250405 | | |
| SCALE: 1:20 | | | SHEET 1 OF 1 | |

Model: 12APX-192

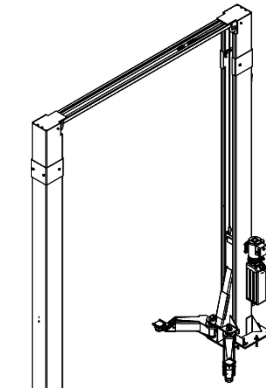
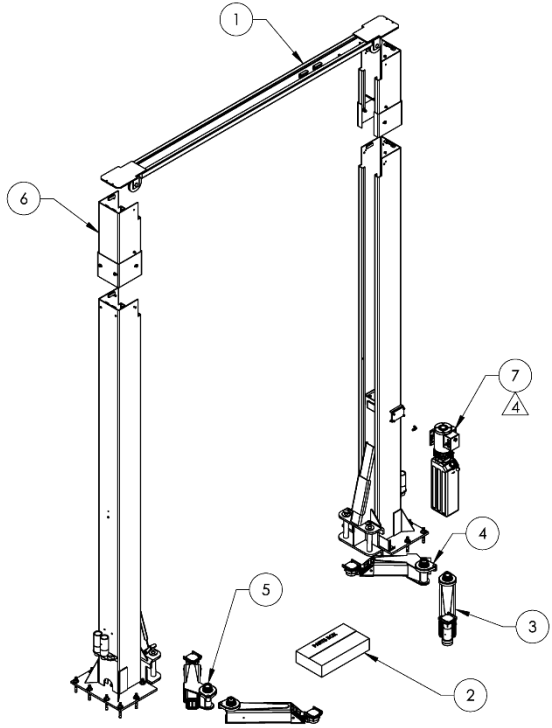

ISOMETRIC VIEW
FOR REFERENCE ONLY
DO NOT SCALE

| ITEM NO | PART NUMBER | DESCRIPTION | QTY |
|---------|-------------|--|-----|
| 1 | 5245429 | 12APX-192 LIFT SUPERSTRUCTURE | 1 |
| 2 | 5250406 | 12APX-192 PARTS BOX | 1 |
| 3 | 5211009 | 12APX/SRT/APF TRIPLE TELESCOPING ARM, PRE-ASSEMBLY KIT | 2 |
| 4 | 5211007 | 12APX/SRT/APF ASYMMETRIC LEFT ARM, PRE-ASSEMBLY KIT | 1 |
| 5 | 5211008 | 12APX/SRT/APF ASYMMETRIC RIGHT ARM, PRE-ASSEMBLY KIT | 1 |
| 6 | 5216362 | 12APX/16AP/20AP POST EXTENSION ASSEMBLY | 2 |
| 7 | REF | POWER UNIT | 1 |

DO NOT SCALE DRAWING

NAME: IM DATE: 02/26/2025

DRAWN: IM

CHECKED: SC 12/11/2025

THIRD ANGLE PROJECTION

30440 AGOURA RD
AGOURA HILLS, CA 91301

BendPak

TITLE: 12APX-192 PRODUCTION LIFT VER B

SIZE: DWG. NO. A 5260731 REV

SCALE: 1:40 SHEET 1 OF 3

- NOTE: UNLESS OTHERWISE SPECIFIED**
- REFER TO MODEL FOR ADDITIONAL INFORMATION
 - SEE COLORS & GRAPHICS FOR LABEL PLACEMENT
 - SEE SHIPPING INSTRUCTIONS FOR FINAL PACKAGING
 - POWER UNIT REFERENCE ON PURCHASE ORDER

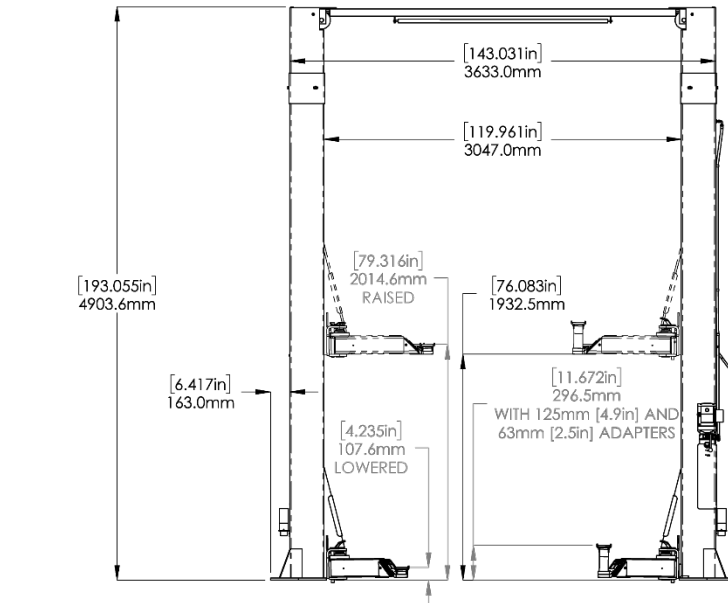
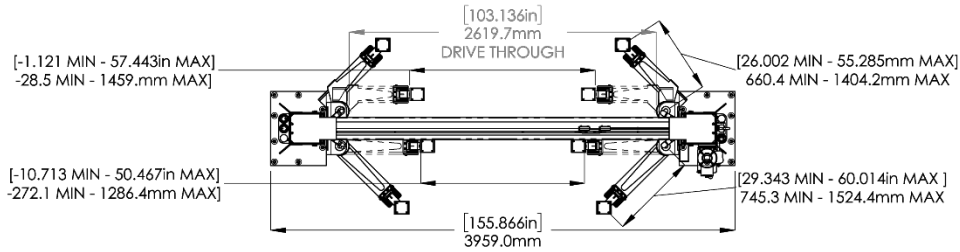

BendPak

30440 AGOURA RD
AGOURA HILLS, CA 91301

TITLE: 12APX-192 PRODUCTION LIFT VER B

SIZE: DWG. NO. A 5260731 REV

SCALE: 1:38 SHEET 2 OF 3

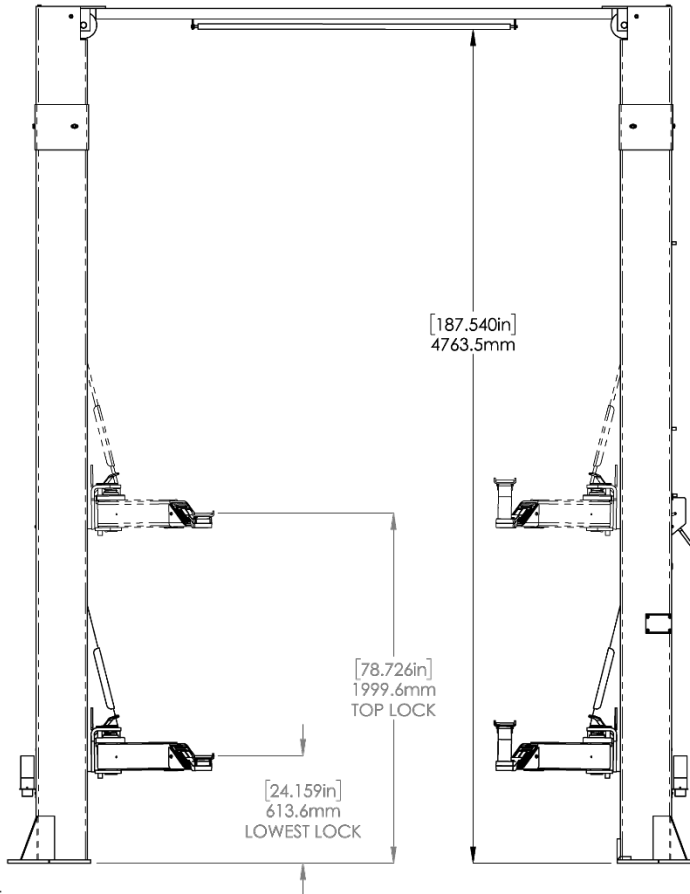

1. SAFETY LOCK POSITIONS: 15
2. SPACED EVERY: 99.0mm / 3.898"

BP BendPak
 30440 AGOURA RD.
 AGOURA HILLS, CA 91301

TITLE: 12APX-192
 PRODUCTION LIFT VER B

SIZE DWG. NO. 5260731 REV

A SCALE: 1:28 SHEET 3 OF 3

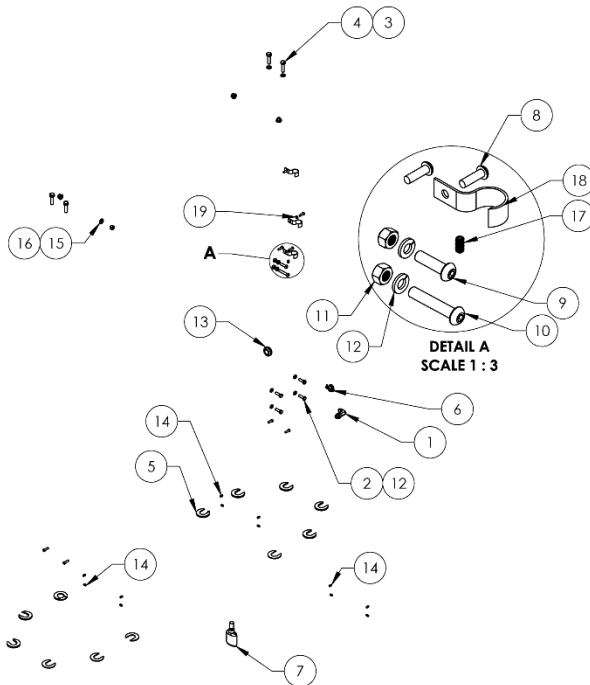

WHERE USED
 12APX SERIES

NOTE: UNLESS OTHERWISE SPECIFIED
 1. REFER TO MODEL FOR ADDITIONAL INFORMATION

| ITEM NO | PART NUMBER | DESCRIPTION | QTY |
|---------|-------------|---------------------------------|-----|
| 1 | 5550183 | FTG ELB -06 JIC -06L ORB | 1 |
| 2 | 5530010 | HHB M8 x 1.25 x 25 FT, CL 10.9 | 4 |
| 3 | 5545200 | WASHER M10 x Ø18 SL, CL10.9 | 4 |
| 4 | 5530302 | HHB M10 x 1.5 x 40 FT, CL 10.9 | 4 |
| 5 | 5545535 | C WASHER SHIM FOR LIFTS | 20 |
| 6 | 5520140 | ROMEX CONNECTOR 3/8 #6623 | 1 |
| 7 | 5580012 | LIQUID PTFE THREAD SEALANT 50ml | 1 |
| 8 | 5530065 | BHSK M6 x 1.0 x 20 FT, CL 10.9 | 8 |
| 9 | 5530412 | BHSK M8 x 1.25 x 30 CL10.9 | 1 |
| 10 | 5530413 | BHSK M8 x 1.25 x 45 CL10.9 | 1 |
| 11 | 5535001 | NUT M8 x 1.25 NL, CL10.9 | 2 |
| 12 | 5545202 | WASHER M8 x Ø15 SL, CL10.9 | 6 |
| 13 | 5520001 | RUBBER GROMMET, 3/4 I.D. | 1 |
| 14 | 5530551 | SSS M6 x 1.0 x 12 NL CONE | 12 |
| 15 | 5545341 | WASHER M10 x Ø20 FLAT, CL10.9 | 4 |
| 16 | 5535013 | NUT M10 x 1.5 NL, CL10.9 | 4 |
| 17 | 5530460 | SSS M6 x 1.0 x 12 NL FLAT | 1 |
| 18 | 5550492 | 3/4" PIPE STRAP | 3 |
| 19 | 5545005 | WASHER M6 x 12 FLAT, CL 10.9 | 2 |

DO NOT SCALE DRAWINGS

NAME DATE
 DRAWN TM 02/28/2025

CHECKED TM 9/2/2025

THIRD ANGLE PROJECTION

PROPERTY AND CONFIDENTIAL
 THE INFORMATION CONTAINED HEREIN IS THE PROPERTY OF BENDPAK INC. REPRODUCTION OR TRANSMISSION OF THIS INFORMATION WITHOUT THE WRITTEN PERMISSION OF BENDPAK INC. IS PROHIBITED.

BP BendPak
 30440 AGOURA RD.
 AGOURA HILLS, CA 91301

TITLE: 12APX PARTS BAG

SIZE DWG. NO. 5174156 REV

A SCALE: 1:16 SHEET 1 OF 1

NEXT ASSEMBLY
 5250405
 5250406

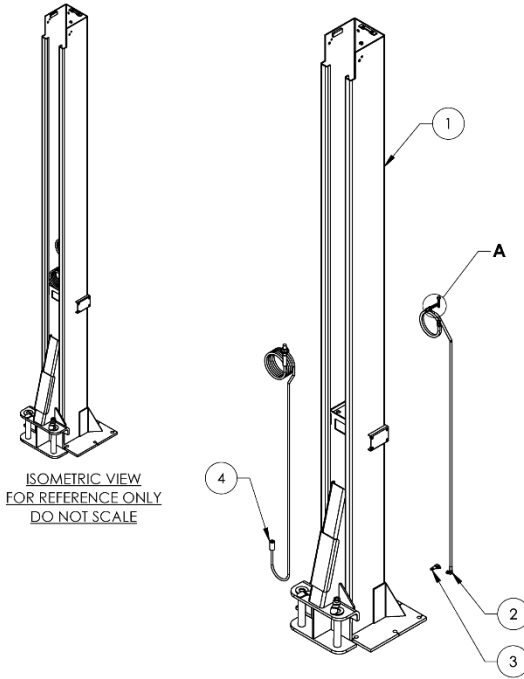

WHERE USED
12APX-192

NOTE: UNLESS OTHERWISE SPECIFIED
1. ASSEMBLE ALL ITEMS PRIOR TO PACKAGING

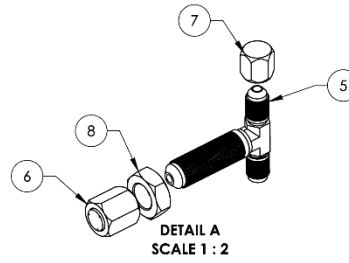

| ITEM NO | PART NUMBER | DESCRIPTION | QTY |
|---------|-------------|--|-----|
| 1 | 5216347 | 12APX POWER SIDE POST ASSEMBLY | 1 |
| 2 | 5570238 | HYDRAULIC HOSE ASSEMBLY Ø6.4 x 3870mm SB | 1 |
| 3 | 5550113 | FTG ELB -04 NPT LL x -04 JIC | 1 |
| 4 | 5595760 | CABLE ASSEMBLY Ø12 x 11660mm ST | 1 |
| 5 | 5550003 | FTG TEE -04JIC x -04JIC x -06JIC | 1 |
| 6 | 5550177 | THREADED FITTING CAP, -06 JIC FEMALE | 1 |
| 7 | 5550054 | THREADED FITTING CAP, -04 JIC FEMALE | 1 |
| 8 | 5535022 | NUT 9/16"-18 JN, Gr 5 | 1 |

DO NOT SCALE DRAWING

NAME: **BP BendPak** 30440 AGOURA RD, AGOURA HILLS, CA 91301

DRAWN: TM 05/28/2025
CHECKED: TM 9/2/2025

TITLE: 12APX-192 POWER SIDE POST, PRE-ASSEMBLY KIT

SIZE: DWG. NO. 5211031 REV

SCALE: 1:25 SHEET 1 OF 2

THIRD ANGLE PROJECTION

PROPRIETARY AND CONFIDENTIAL
THE INFORMATION CONTAINED IN THIS DRAWING IS THE SOLE PROPERTY OF BENDPAK INC.
REPRODUCTION IN PART OR AS A WHOLE WITHOUT THE WRITTEN PERMISSION OF BENDPAK INC. IS PROHIBITED.

NEXT ASSEMBLY
5245429

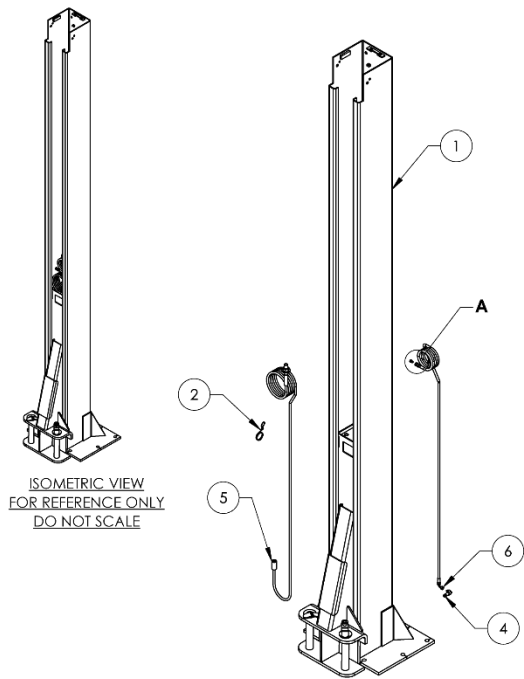

WHERE USED
12APX-192

NOTE: UNLESS OTHERWISE SPECIFIED
1. ASSEMBLE ALL ITEMS PRIOR TO PACKAGING

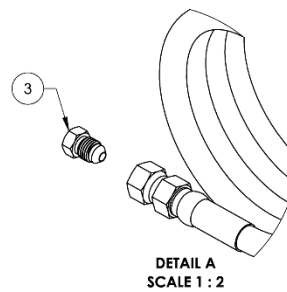

| ITEM NO | PART NUMBER | DESCRIPTION | QTY |
|---------|-------------|---|-----|
| 1 | 5216348 | 12APX OFF SIDE POST ASSEMBLY | 1 |
| 2 | 5595761 | SAFETY CABLE Ø1.8 x 10070mm | 1 |
| 3 | 5550179 | THREADED FITTING PLUG, -04 JIC MALE | 1 |
| 4 | 5550113 | FTG ELB -04 NPT LL x -04 JIC | 1 |
| 5 | 5595760 | CABLE ASSEMBLY Ø12 x 11660mm ST | 1 |
| 6 | 5570255 | HYDRAULIC HOSE ASSEMBLY Ø6.35 x 9168mm SB | 1 |

DO NOT SCALE DRAWING

NAME: **BP BendPak** 30440 AGOURA RD, AGOURA HILLS, CA 91301

DRAWN: TM 05/28/2025
CHECKED: TM 9/2/2025

TITLE: 12APX-192 OFF SIDE POST, PRE-ASSEMBLY KIT

SIZE: DWG. NO. 5211032 REV

SCALE: 1:25 SHEET 1 OF 2

THIRD ANGLE PROJECTION

PROPRIETARY AND CONFIDENTIAL
THE INFORMATION CONTAINED IN THIS DRAWING IS THE SOLE PROPERTY OF BENDPAK INC.
REPRODUCTION IN PART OR AS A WHOLE WITHOUT THE WRITTEN PERMISSION OF BENDPAK INC. IS PROHIBITED.

NEXT ASSEMBLY
5245429

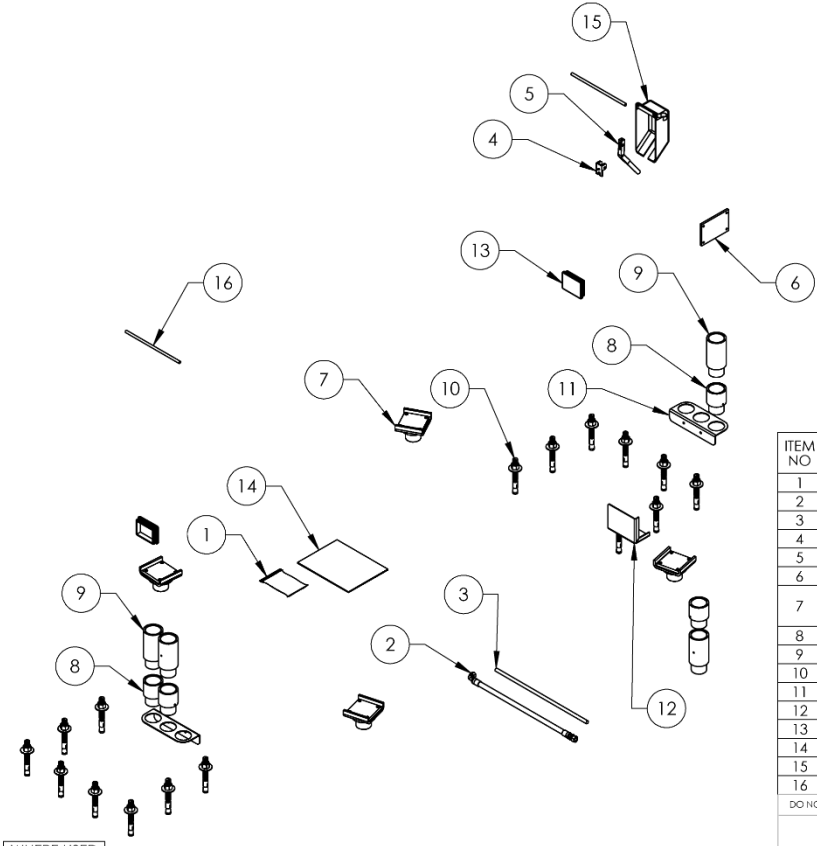

WHERE USED
12APX-192

- NOTE: UNLESS OTHERWISE SPECIFIED**
1. REFER TO MODEL FOR ADDITIONAL INFORMATION
 2. INSERT PARTS BAG INTO PARTS BOX FOR SHIPMENT
 3. HOSES AND CABLES SHOWN REPRESENTATIONAL FORM

| ITEM NO | PART NUMBER | DESCRIPTION | QTY |
|---------|-------------|---|--------|
| 1 | 5174156 | 12APX PARTS BAG | 1 |
| 2 | 5570290 | HYDRAULIC HOSE ASSEMBLY Ø10 x 2790mm SB | 1 |
| 3 | 5520032 | CABLE, AWG 14-2, SOOW | 4925mm |
| 4 | 5700404 | AP SAFETY PIVOT HOLDER | 1 |
| 5 | 5761017 | AP SAFETY HANDLE | 1 |
| 6 | 5715003 | POWER UNIT VIBRATION DAMPENER | 1 |
| 7 | 5215702 | FRAME CRADLE LIFT PAD ADAPTER ASSEMBLY, Ø60mm | 4 |
| 8 | 5746192 | ARM ADAPTER, MEDIUM | 4 |
| 9 | 5746193 | ARM ADAPTER, LONG | 4 |
| 10 | 5530337 | AB 3/4" x 6.3" | 16 |
| 11 | 5701660 | HEIGHT ADAPTER HOLDER, 60mm | 2 |
| 12 | 5701901 | 12APX FOOT GUARD | 1 |
| 13 | 5715196 | POLYETHYLENE COVER BLOCK 105 x 80 | 2 |
| 14 | 5900374 | 12APX INSTALLATION MANUAL | 1 |
| 15 | 5716072 | AP POWER SIDE PLASTIC SAFETY COVER | 1 |
| 16 | 5746166 | DOUBLE THREADED ROD M10 x 1.5 x 295 | 2 |

DO NOT SCALE DRAWING

NAME: **BP BendPak** DATE: 02/26/2025
 DRAWN: TM 02/26/2025
 CHECKED: TM 9/2/2025

30440 AGOURA RD.
AGOURA HILLS, CA 91301

DIMENSIONS ARE IN MM

THIRD ANGLE PROJECTION

TITLE: 12APX-192 PARTS BOX

SCALE: 1:20

PROPRIETARY AND CONFIDENTIAL
 THE INFORMATION CONTAINED IN THIS DRAWING IS THE SOLE PROPERTY OF BENDPAK INC. ANY REPRODUCTION OR TRANSMISSION IN ANY FORM OR BY ANY MEANS WITHOUT THE WRITTEN PERMISSION OF BENDPAK INC. IS PROHIBITED.

SCALE: 1:20 SHEET 1 OF 1

NEXT ASSEMBLY
5260731

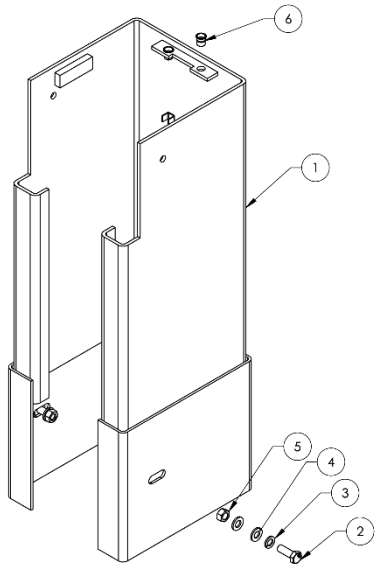

WHERE USED
12AP-192
16AP-192
20AP-192

- NOTE: UNLESS OTHERWISE SPECIFIED**
1. REFER TO MODEL FOR ADDITIONAL INFORMATION
 2. SEE SHIPPING INSTRUCTIONS FOR FINAL PACKAGING

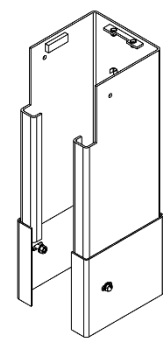

ISOMETRIC VIEW
FOR REFERENCE ONLY
DO NOT SCALE

| ITEM NO | PART NUMBER | DESCRIPTION | QTY |
|---------|-------------|---------------------------------|-----|
| 1 | 5602148 | 12APX/16AP/20AP POST EXTENSION | 1 |
| 2 | 5530076 | HHB M12 x 1.75 x 35 FT. CL 10.9 | 4 |
| 3 | 5545201 | WASHER M12 x 21 SL. CL 10.9 | 4 |
| 4 | 5545347 | WASHER M12 x 24 FLAT. CL 10.9 | 8 |
| 5 | 5535354 | NUT M12 x 1.75, CL 10.9 | 4 |
| 6 | 5535059 | NUT M10 x 1.5 x 20.5, RIVET | 2 |

DO NOT SCALE DRAWING

NAME: **BP BendPak** DATE: 03/04/2025
 DRAWN: TMS 03/04/2025
 CHECKED: TMS

30440 AGOURA RD.
AGOURA HILLS, CA 91301

DIMENSIONS ARE IN MM

THIRD ANGLE PROJECTION

TITLE: 12APX/16AP/20AP POST EXTENSION ASSEMBLY

SCALE: 1:6

PROPRIETARY AND CONFIDENTIAL
 THE INFORMATION CONTAINED IN THIS DRAWING IS THE SOLE PROPERTY OF BENDPAK INC. ANY REPRODUCTION OR TRANSMISSION IN ANY FORM OR BY ANY MEANS WITHOUT THE WRITTEN PERMISSION OF BENDPAK INC. IS PROHIBITED.

SCALE: 1:6 SHEET 1 OF 1

NEXT ASSEMBLY
5210517
5210519
5260731
5260733
5260735

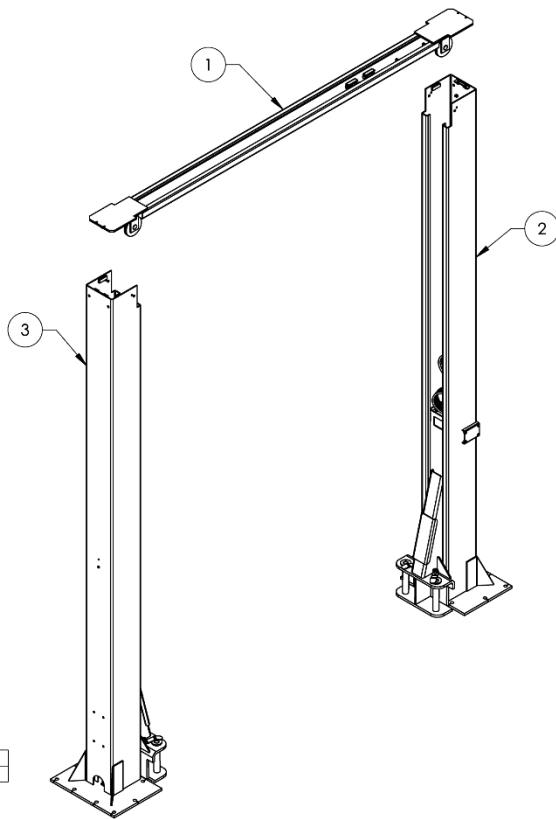

WHERE USED
12APX-192

- NOTE: UNLESS OTHERWISE SPECIFIED:**
1. REFER TO MODEL FOR ADDITIONAL INFORMATION
 2. SEE SHIPPING INSTRUCTIONS FOR FINAL PACKAGING

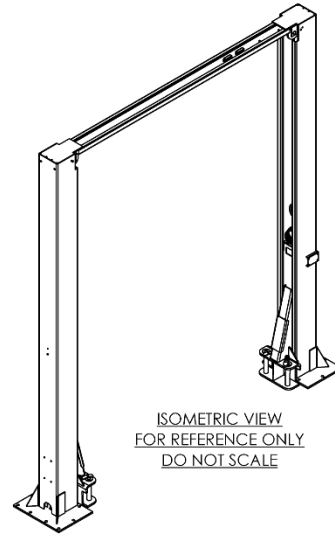

| ITEM NO | PART NUMBER | DESCRIPTION | QTY |
|---------|-------------|---|-----|
| 1 | 5211024 | 12APX TOP TROUGH, PRE-ASSEMBLY KIT | 1 |
| 2 | 5211031 | 12APX-192 POWER SIDE POST, PRE-ASSEMBLY KIT | 1 |
| 3 | 5211032 | 12APX-192 OFF SIDE POST, PRE-ASSEMBLY KIT | 1 |

| | | | | |
|-----------------------|----|--|------|---|
| DO NOT SCALE DRAWING | | NAME | DATE | BP BendPak 30440 AGOURA RD. AGOURA HILLS, CA 91301 |
| DRAWN | TM | 06/02/2025 | | |
| CHECKED | | THIRD ANGLE PROJECTION | | TITLE: 12APX-192 LIFT SUPERSTRUCTURE |
| DIMENSIONS ARE IN MM | | | | SIZE: DWG. NO. 5245429 |
| | | <small>PROPRIETARY AND CONFIDENTIAL THE INFORMATION ON THIS DRAWING IS THE SOLE PROPERTY OF BENDPAK INC. IT IS REPRODUCED IN PART OR AS A WHOLE WITHOUT THE WRITTEN PERMISSION OF BENDPAK INC. IT IS PROHIBITED.</small> | | REV |
| NEXT ASSEMBLY 5260731 | | SCALE: 1:32 | | SHEET 1 OF 1 |

Automotive Lift Institute (ALI) Store

You probably checked the **ALI's Directory of Certified Lifts** (www.autolift.org/ali-directory-of-certified-lifts/) before making your most recent Lift purchase, but did you know the **ALI Store** (www.autolift.org/ali-store/) offers a variety of professional, easy-to-use, and reasonably priced training and safety materials that will make your garage a safer place to work?

The ALI Store is your trusted source for workplace safety!



Lifting It Right Online Certificate Course. Make *sure* you and your people are lifting vehicles the right way.



ALI Lift Inspector Certification Program Registration. Become a ALI Certified Lift Inspector.

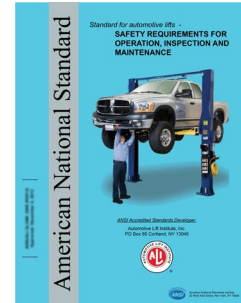

ANSI/ALI ALOIM Standard for Automotive Lifts. Safety Requirements for Operation, Inspection, and Maintenance.

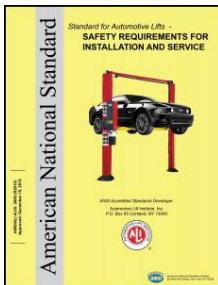

ANSI/ALI ALIS Standard. Safety Requirements for Installation and Service.

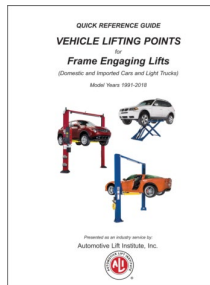

Guide to Hitting Vehicle Lifting Points for Frame-Engaging Lifts. Don't eyeball your lifting points, *know* where they are.



Lift Operator Safety Materials. Five safety documents in a single package.

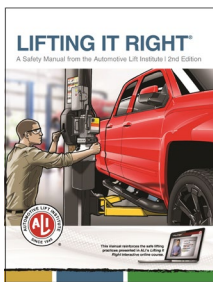

Lifting It Right. A hardcopy version of the *Lifting It Right* safety manual from the Automotive Lift Institute.



Uniform Warning Labels and Placards for 2-Posts. Labels in Mandarin, French Canadian, and Spanish are also available.

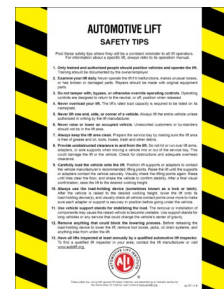

Safety Tips Card. Reminds your people of 13 key safety tips to follow daily.

Visit today and get the training and materials you need to work safely:
www.autolift.org/ali-store/.

