



IMPORTANT SAFETY INSTRUCTIONS SAVE THESE INSTRUCTIONS

PLEASE READ THE ENTIRE CONTENTS OF THIS MANUAL PRIOR TO INSTALLATION AND OPERATION. BY PROCEEDING WITH LIFT INSTALLATION AND OPERATION YOU AGREE THAT YOU FULLY UNDERSTAND AND COMPREHEND THE FULL CONTENTS OF THIS DOCUMENT. FORWARD THIS MANUAL TO ALL OPERATORS. FAILURE TO OPERATE THIS EQUIPMENT AS DIRECTED MAY CAUSE INJURY OR DEATH.

Manual Revision A4 - March 2020
Manual Part Number 5900952

INSTALLATION AND OPERATION MANUAL

12,000 POUND CAPACITY SURFACE MOUNTED TWO-POST LIFTS

MODEL:
XPR-12FDL

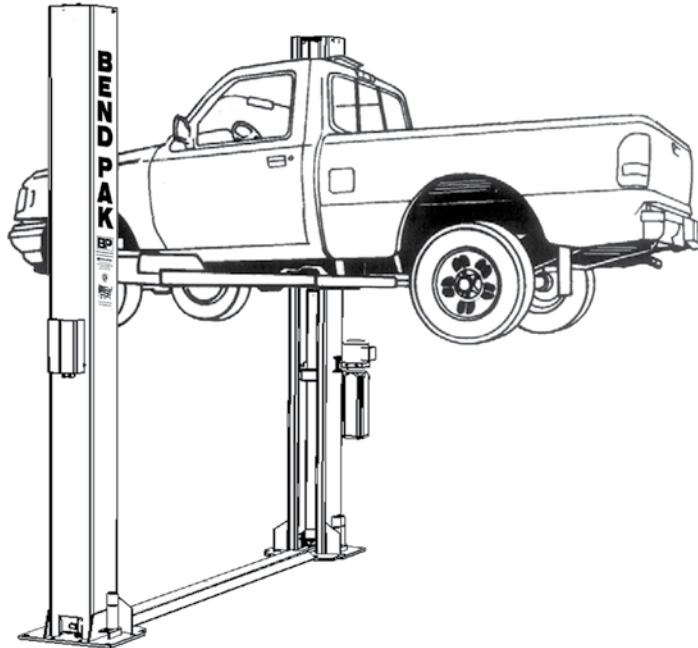

READ FIRST



Do not operate this machine until you read and understand all the dangers, warnings and cautions in this manual.

RECEIVING

The shipment should be thoroughly inspected as soon as it is received. The signed Bill of Lading is acknowledgement by the shipping carrier as receipt of this product as listed in your invoice as being in a good condition of shipment. If any of these goods listed on this Bill of Lading are missing or damaged, do not accept goods until the shipping carrier makes a notation on the freight bill of the missing or damaged goods. Do this for your own protection.

BE SAFE

Your new lift was designed and built with safety in mind. However, your overall safety can be increased with proper training and thoughtful operation on the part of the operator. DO NOT operate or repair this equipment without reading this manual and the important safety instructions shown inside. Keep this operation manual near the lift at all times. Make sure that ALL USERS read and understand this manual.



1645 Lemonwood Dr.
Santa Paula, CA. 93060, USA
Toll Free 1-800-253-2363
Tel: 1-805-933-9970
www.bendpak.com

12,000 POUND CAPACITY SURFACE MOUNTED TWO-POST LIFTS

This instruction manual has been prepared especially for you. Your new lift is the product of over 40 years of continuous research, testing and development; it is the most technically advanced lift on the market today.

READ THIS ENTIRE MANUAL BEFORE INSTALLATION & OPERATION BEGINS.

RECORD HERE THE LIFT AND
POWER UNIT INFORMATION WHICH IS LOCATED
ON THE SERIAL NUMBER
DATA PLATES ON THE LIFT AND
ON THE POWER UNIT

Power Unit Model # _____
Power Unit Date Of Mfg. _____
Power Unit Serial # _____

This information is required when
calling for parts or warranty issues.

PRODUCT WARRANTY

Our comprehensive product warranty means more than a commitment to you; it's also a commitment to the value of your new BendPak lift. For full warranty details and to register your new lift contact your nearest BendPak dealer or visit:

<http://www.bendpak.com/support/warranty/>

NOTE:

Every effort has been taken to ensure complete and accurate instructions have been included in this manual, however, possible product updates, revisions and or changes may have occurred since this printing. BendPak Ranger reserves the right to change specifications without incurring any obligation for equipment previously or subsequently sold.

Not responsible for typographical errors.

IMPORTANT NOTICE

Do not attempt to install this lift if you have never been trained on basic automotive lift installation procedures. Never attempt to lift components without proper lifting tools such as forklift or cranes. Stay clear of any moving parts that can fall and cause injury. These instructions must be followed to ensure proper installation and operation of your lift. Failure to comply with these instructions can result in serious bodily harm and void product warranty. Manufacturer will assume no liability for loss or damage of any kind, expressed or implied resulting from improper installation or use of this product.

PLEASE READ ENTIRE MANUAL PRIOR TO INSTALLATION.

DEFINITIONS OF HAZARD LEVELS

Identify the hazard levels used in this manual with the following definitions and signal words:



Watch for this symbol: It Means: Immediate hazards which will result in severe personal injury or death.



Watch for this symbol: It Means: Hazards or unsafe practices which could result in severe personal injury or death.



Watch for this symbol: It Means: Hazards or unsafe practices which may result in minor personal injury, product or property damage.

OWNER'S RESPONSIBILITY

To maintain the lift and user safety, the responsibility of the owner is to read and follow these instructions:

- ◆ Follow all installation and operation instructions.
- ◆ Make sure installation conforms to all applicable Local, State, and Federal Codes, Rules, and Regulations; such as State and Federal OSHA Regulations and Electrical Codes.
- ◆ Carefully check the lift for correct initial function.
- ◆ Read and follow the safety instructions. Keep them readily available for machine operators.
- ◆ Make certain all operators are properly trained, know how to safely and correctly operate the unit, and are properly supervised.
- ◆ Allow unit operation only with all parts in place and operating safely.
- ◆ Carefully inspect the unit on a regular basis and perform all maintenance as required.
- ◆ Service and maintain the unit only with authorized or approved replacement parts.
- ◆ Keep all instructions permanently with the unit and all decals on the unit clean and visible.

BEFORE YOU BEGIN

Receiving:

The shipment should be thoroughly inspected as soon as it is received. The signed bill of lading is acknowledgement by the carrier of receipt in good condition of shipment covered by your invoice. If any of the goods called for on this bill of lading are shorted or damaged, do not accept them until the carrier makes a notation on the freight bill of the shorted or damaged goods. Do this for your own protection.

NOTIFY THE CARRIER AT ONCE if any hidden loss or damage is discovered after receipt and request the carrier to make an inspection. If the carrier will not do so, prepare a signed statement to the effect that you have notified the carrier (on a specific date) and that the carrier has failed to comply with your request.

IT IS DIFFICULT TO COLLECT FOR LOSS OR DAMAGE AFTER YOU HAVE GIVEN THE CARRIER A CLEAR RECEIPT. File your claim with the carrier promptly. Support your claim with copies of the bill of lading, freight bill, invoice, and photographs, if available. Our willingness to assist in helping you process your claim does not make BendPak responsible for collection of claims or replacement of lost or damaged materials.

TABLE OF CONTENTS

Contents	Page No.
Warranty / Serial Number Information	2
Definitions of Hazard Levels	3
Owner's Responsibility	3
Before You Begin	3
Installer/Operator Agreement/ Protective Equipment	5
Safety / Warning Instructions	6
Tools Required	7
Step 1 / Selecting Site	7
Step 2 / Floor Requirements	7
Concrete Specifications	7
Assembly View / Description of Parts	8
Floorplan.	9
Clearances.	10
Step 3 / Column Preparation	11
Step 4 / Site Layout / Floor Plan	12
Step 5 / Installing Power Side Column	13
Step 6 / Installing Off Side Column	13
Step 7 / Mounting The Hydraulic Power Unit	14
Step 8 / Installing the Safeties and Safety Cable	14-16
Step 9 / Installing Hydraulic Lines	16-17
Step 10 / Routing the Equalizer Cables	17-18
Step 11 / Installing Floor Plate and Safety Cover	19
Step 12 / Installing the Lift Arms	19-20
Carriage Stop Bolt Installation Warning.	21
Step 13 / Power Unit Connection	22-23
Step 14 / Lift Start Up / Final Adjustments	24
Post Installation Checklist	24
Step 15 / Lubrication.	24
Step 16 / Bleeding the Cylinders	24
Optional Equipment Installation.	25-27
Step 17 / Operation/ Maintenance	28-34
Safe Lift Operation.	35-38
Troubleshooting Guide	39-43
Torque Recommendations	44
Part Number Lists	45-50
Certificate of Compliance	52
Maintenance Records	53-55

INSTALLER / OPERATOR PLEASE READ AND FULLY UNDERSTAND. BY PROCEEDING YOU AGREE TO THE FOLLOWING.

- ◆ I have visually inspected the site where the lift is to be installed and verified the concrete to be in good condition and free of cracks or other defects. I understand that installing a lift on cracked or defective concrete could cause lift failure resulting in personal injury or death.
- ◆ I understand that a level floor is required for proper installation and level lifting.
- ◆ I understand that I am responsible if my floor is of questionable slope and that I will be responsible for all charges related to pouring a new level concrete slab if required and any charges.
- ◆ I understand that BendPak lifts are supplied with concrete fasteners meeting the criteria of the American National Standard "Automotive Lifts - Safety Requirements for Construction, Testing, and Validation" ANSI/ALI ALCTV-2006, and that I will be responsible for all charges related to any special, regional, structural, and/or seismic anchoring requirements specified by any other agencies and/or codes such as the Uniform Building Code (UBC) and/or International Building Code (IBC).
- ◆ I will assume full responsibility for the concrete floor and condition thereof, now or later, where the above equipment model is to be installed. Failure to follow Danger, Warning, and Caution instructions may lead to serious personal injury or death to operator or bystander or damage to property.
- ◆ I understand that BendPak lifts are designed to be installed in indoor locations only. Failure to follow installation instructions may lead to serious personal injury or death to operator or bystander or damage to property or lift.



CAUTION

The safe operating temperature range for this product is
41° F - 104° F



THIS SYMBOL POINTS OUT IMPORTANT SAFETY INSTRUCTIONS WHICH IF NOT FOLLOWED COULD ENDANGER THE PERSONAL SAFETY AND/OR PROPERTY OR YOURSELF AND OTHERS AND CAN CAUSE PERSONAL INJURY OR DEATH. READ AND FOLLOW ALL INSTRUCTIONS IN THIS MANUAL BEFORE ATTEMPTING TO OPERATE THIS MACHINE.



DANGER

Failure to follow Danger, Warning, and Caution instructions may lead to serious personal injury or death to operator or bystander or damage to property.



WARNING

Please read the entire manual prior to installation. Do not operate this machine until you have read and have understood all of the Danger, Warning and Caution alerts in this manual. For additional copies or further information, contact:

BendPak Inc.

1645 Lemonwood Dr.

Santa Paula, CA. 93060

1-805-933-9970

www.bendpak.com

INSTALLER / OPERATOR PROTECTIVE EQUIPMENT

Personal protective equipment helps make installation and operation safer, however, it does not take the place of safe operating practices. Always wear durable work clothing during any installation and/or service activity. Shop aprons or shop coats may also be worn, however loose-fitting clothing should be avoided.



Tight-fitting leather gloves are recommended to protect the technician's hands when handling parts. Sturdy leather steel-toe work shoes and oil resistant soles should be used by all service personnel to help prevent injury during typical installation and operation activities.

Eye protection is essential during installation and operation activities. Safety glasses with side shields, goggles, or face shields are acceptable. Back belts provide support during lifting activities and are also helpful in providing worker protection. Consideration should also be given to the use of hearing protection if service activity is performed in an enclosed area, or if noise levels are high.

INTRODUCTION

1. Carefully remove the crating and packing materials. CAUTION! Be careful when cutting steel banding material as items may become loose and fall causing personal harm or injury.

2. Check the voltage, phase, and proper amperage requirements for the motor shown on the motor plate. Electrical work should be performed only by a certified electrician.

IMPORTANT SAFETY INSTRUCTIONS

Read these safety instructions entirely. Do not attempt to install this lift if you have never been trained on basic automotive lift installation procedures. Never attempt to lift components without proper lifting tools such as forklift or cranes. Stay clear of any moving parts that may fall and cause injury. When using your garage equipment, basic safety precautions should always be followed, including the following:

1. Read and understand all instructions and all safety warnings before operating lift.
2. Care must be taken as burns can occur from touching hot parts.
3. Do not operate equipment with a damaged cord or if the equipment has been dropped or damaged until it has been examined by a qualified service person.
4. Do not let a cord hang over the edge of the table, bench, or counter or come in contact with hot manifolds or moving fan blades.
5. If an extension cord is necessary, a cord with a current rating equal to or more than that of the equipment should be used. Cords rated for less current than the equipment may overheat. Care should be taken to arrange the cord so that it will not be tripped over or pulled.
6. Always unplug equipment from electrical outlet when not in use. Never use the cord to pull the plug from the outlet. Grasp plug and pull to disconnect.
7. Let equipment cool completely before putting away. Loop cord loosely around equipment when storing.
8. To reduce the risk of fire, do not operate equipment in the vicinity of open containers of flammable liquids (gasoline).
9. Adequate ventilation should be provided when working on operating internal combustion engines.
10. Keep hair, loose clothing, fingers, and all parts of body away from moving parts. Keep feet clear of lift when lowering. Avoid pinch points.
11. DANGER! To reduce the risk of electric shock, do not use on wet surfaces or expose to rain. The power unit used on this lift contains high voltage. Disconnect power at the receptacle or at the circuit breaker switch before performing any electrical repairs. Secure plug so that it cannot be accidentally plugged in during service. or mark circuit breaker switch so that it cannot be accidentally switched on during service.
12. Use only as described in this manual. Use only manufacturer's recommended attachments.



13. ALWAYS WEAR SAFETY GLASSES. Everyday eyeglasses only have impact resistant lenses, they are not safety glasses.



14. Consider work environment. Keep work area clean. Cluttered work areas invite injuries. Keep areas well lit.

15. Guard against electric shock. This lift must be grounded while in use to protect operator from electric shock. Never connect the green power cord wire to a live terminal. This is for ground only.

16. Only trained operators should operate this lift. All non-trained personnel should be kept away from the work area. Never let non-trained personnel come in contact with, or operate lift.

17. DO NOT override self-closing lift controls.

18. Clear area if vehicle is in danger of falling.

19. ALWAYS make sure the safeties are engaged before attempting to work on or near a vehicle.

20. WARNING! RISK OF EXPLOSION. This equipment has internal arcing or sparking parts which should not be exposed to flammable vapors. This machine should not be located in a recessed area or below floor level.



21. MAINTAIN WITH CARE. Keep lift clean for better and safer performance. Follow manual for proper lubrication and maintenance instructions. Keep control handles and/or buttons dry, clean and free from grease and oil.

22. Check for damaged parts. Check for alignment of moving parts, breakage of parts or any condition that may affect operation of lift. Do not use lift if any component is broken or damaged.

23. NEVER remove safety related components from the lift. Do not use lift if safety related components are missing or damaged.

24. STAY ALERT. Use common sense and watch what you are doing. Remember, SAFETY FIRST.

SAVE THESE INSTRUCTIONS

TOOLS REQUIRED

- ◆ Rotary Hammer Drill or Similar
- ◆ 3/4" Masonry Bit
- ◆ Hammer
- ◆ 4 Foot Level
- ◆ Open-End Wrench Set: SAE/Metric
- ◆ Socket And Ratchet Set: SAE/Metric
- ◆ Hex-Key / Allen Wrench Set
- ◆ Large Crescent Wrench
- ◆ Large Pipe Wrench
- ◆ Crow Bar
- ◆ Chalk Line
- ◆ Medium Flat Screwdriver
- ◆ Tape Measure: 25 Foot Minimum
- ◆ Needle Nose Pliers

IMPORTANT NOTICE

These instructions must be followed to ensure proper installation and operation of your lift. Failure to comply with these instructions can result in serious bodily harm and void product warranty. Manufacturer will assume no liability for loss or damage of any kind, expressed or implied resulting from improper installation or use of this product.

PLEASE READ ENTIRE MANUAL PRIOR TO INSTALLATION

STEP 1

(Selecting Site)

Before installing your new lift, check the following.

1. **LIFT LOCATION:** Always use architects plans when available. Check layout dimension against floor plan requirements making sure that adequate space is available.
2. **OVERHEAD OBSTRUCTIONS:** The area where the lift will be located should be free of overhead obstructions such as heaters, building supports, electrical lines etc.
3. **DEFECTIVE FLOOR:** Visually inspect the site where the lift is to be installed and check for cracked or defective concrete.



4. **OPERATING TEMPERATURE.** Operate lift only between temperatures of 41° -104° F.
5. Lift is designed for **INDOOR INSTALLATION ONLY.** Outdoor use is prohibited. Always follow warnings illustrated on equipment labels.

STEP 2

(Floor Requirements)



This lift must be installed on a solid level concrete floor with no more than 3-degrees of slope. Failure to do so could cause personal injury or death.

A level floor is suggested for proper use and installation and level lifting. If a floor is of questionable slope, consider a survey of the site and/or the possibility of pouring a new level concrete slab.



- ◆ **DO NOT** install or use this lift on any asphalt surface or any surface other than concrete.
- ◆ **DO NOT** install or use this lift on expansion seams or on cracked or defective concrete.
- ◆ **DO NOT** install or use this lift on a second / elevated floor without first consulting building architect.
- ◆ **DO NOT** install this lift outside. It is only approved for indoor installations.
- ◆ Refer to ANSI/ALI ALIS Standard (R2015) *Safety Requirements for Installation and Service* for more information about safely installing your Lift.

CONCRETE SPECIFICATIONS

LIFT MODEL	CONCRETE REQUIREMENTS
XPR-12FDL	6.5" Min. Thickness / 3,000 PSI



All models **MUST** be installed on 3,000 PSI concrete only, conforming to the minimum requirements shown above. New concrete must be adequately cured by at least 28 days minimum.

IMPORTANT NOTE:

BendPak lifts are supplied with installation instructions and concrete fasteners meeting the criteria as prescribed by the American National Standard "Automotive Lifts - Safety Requirements for Construction, Testing, and Validation" ANSI/ALI ALCTV-2011. Lift buyers are responsible for any special regional structural and/or seismic anchoring requirements specified by any other agencies and/or codes such as the Uniform Building Code (UBC) and/or International Building Code (IBC).



When removing the lift from shipping angles, pay close attention as the posts can slide and can cause injury. Prior to removing the bolts make sure the posts are held securely by a fork lift or some other heavy lifting device.

PARTS INVENTORY

Be sure to take a complete inventory of parts prior to beginning installation.

Description	Qty
Floorplate	1
Arm Assemblies	4
Rear Arm Assembly	2
Frame Contact Pads	4
Frame Cradle Pads	4
Off Side Column with Carriage Assembly	1
Power Side Column with Carriage Assembly	1
Hydraulic Cylinder	2
Parts Box (Packing List Enclosed)	1
Parts Bag (Packaged in Part Box)	1
Hydraulic Power Unit	1

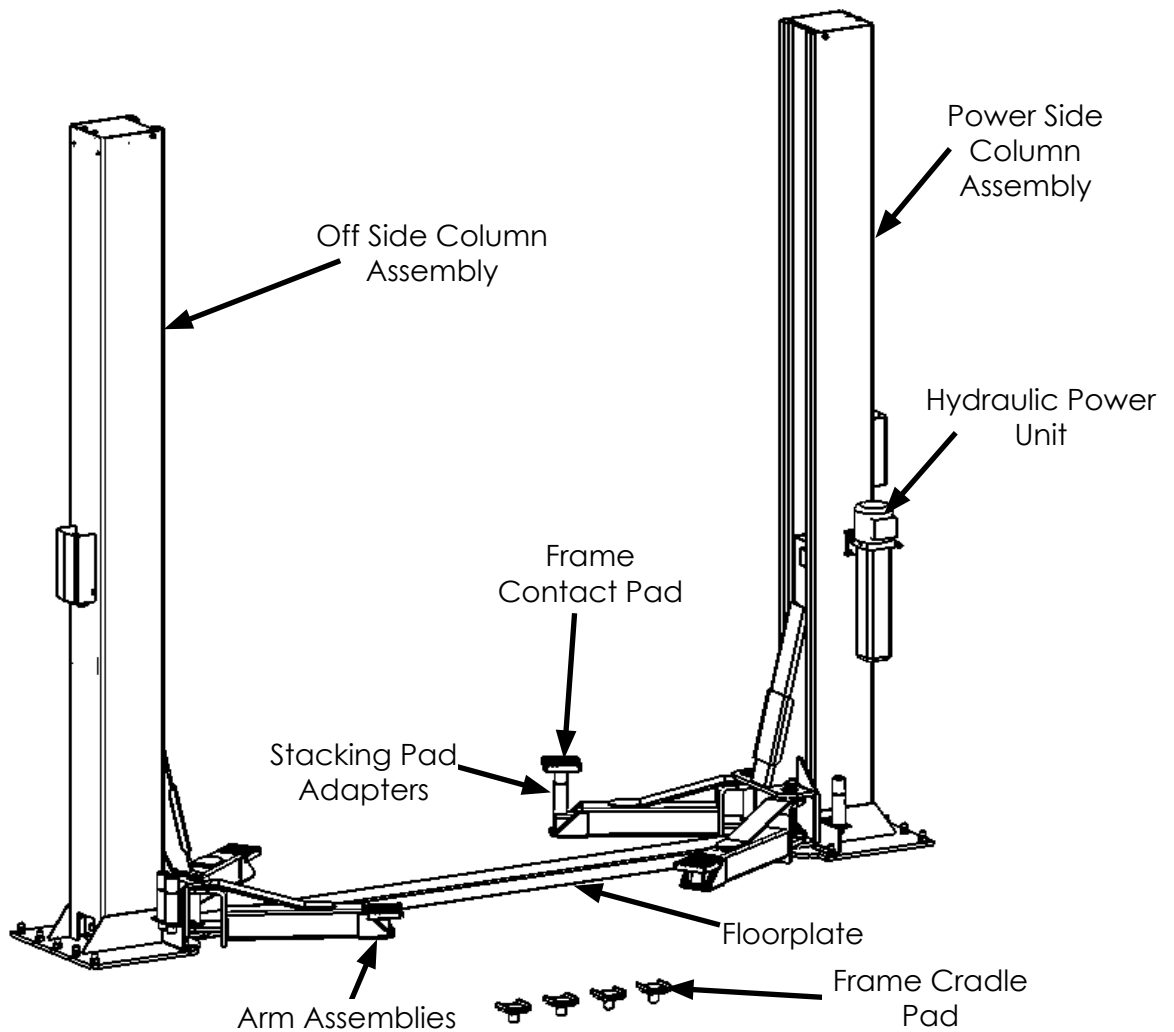

FLOOR PLAN

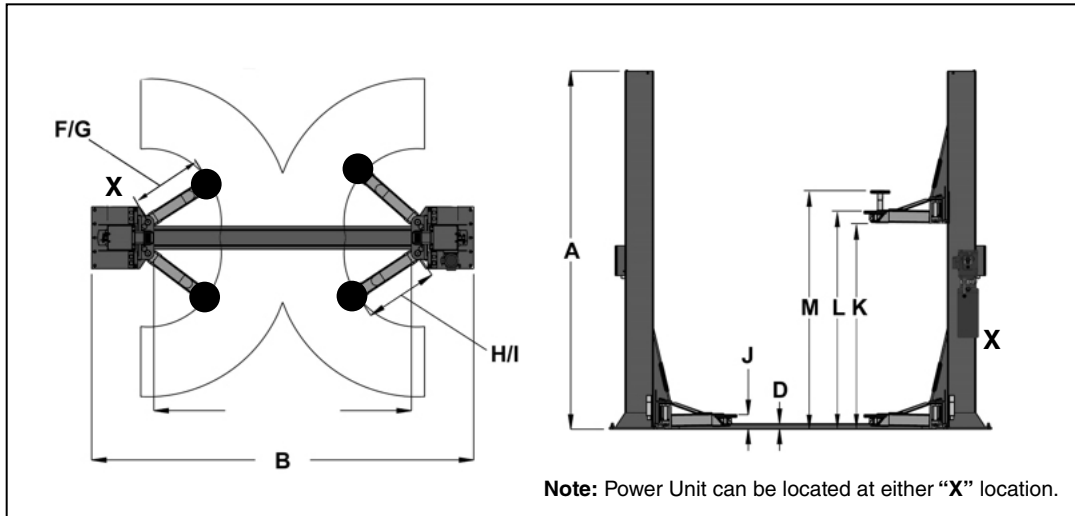

MODEL	XPR-12FDL
Lifting Capacity	12,000Lbs. / 5443Kg.
*Max Capacity/ Front Axle	6,000Lbs. / 2722Kg.
*Max Capacity/ Rear Axle	6,000Lbs. / 2722Kg.
A- Height Overall:	144" / 3403mm.
B -Width Overall (Outside of Base Plate)	155" / 3937mm.
D- Cover Height	2" / 51mm.
F -Reach (Front Arm Min.):	39" / 991mm.
G -Reach (Front Arm Max.):	59" / 1499mm.
H- Reach (Rear Arm Min.):	39" / 991mm.
I- Reach (Rear Arm Max.):	59" / 1499mm.
J- Min. Pad Height:	5" / 127mm.
K- Rise:	69" / 1753mm.
L -Max Lift Height (Pad Only):	74"/1880mm
M - Max Lift Height (6" Adapter):	80" /2032mm
Motor(**)	220VAC / 60Hz.1Ph.
Time of Full Rise:	55 Seconds
Emission sound pressure at Operator Position < 70 dB(A)	
* Special Voltages Available Upon Request.	
The design, material and specifications are subject to change without notice.	

CLEARANCES

XPR-12FDL

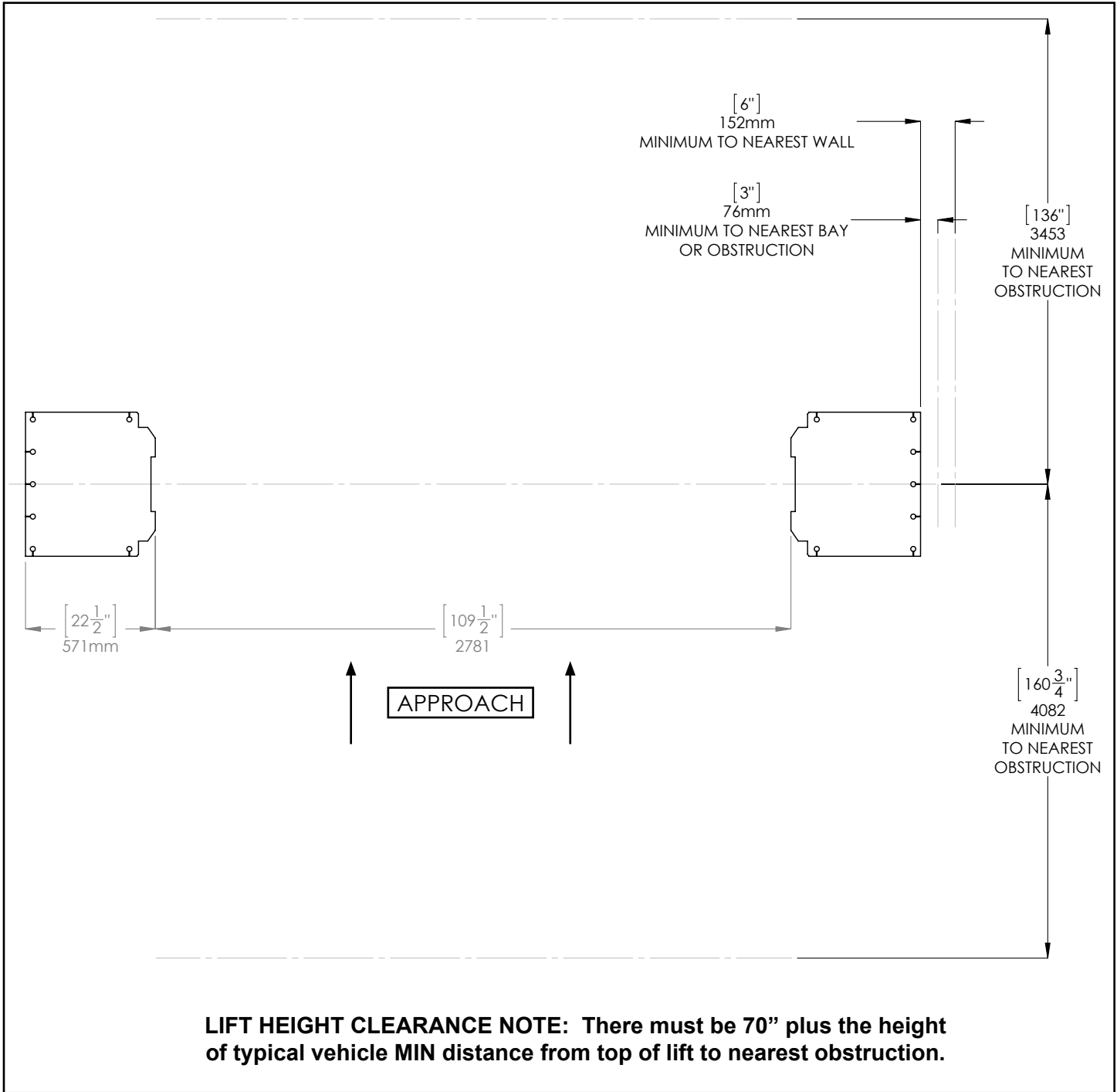

STEP 3
(Column Preparation)
 COMPLETE THE FOLLOWING
 PRIOR TO RAISING THE COLUMNS

1. Prior to raising posts, slide each carriage upwards to expose the cylinder port in the base of the hydraulic cylinder and to aid in sheave removal and equalizer cable routing. (See Fig 3.1)

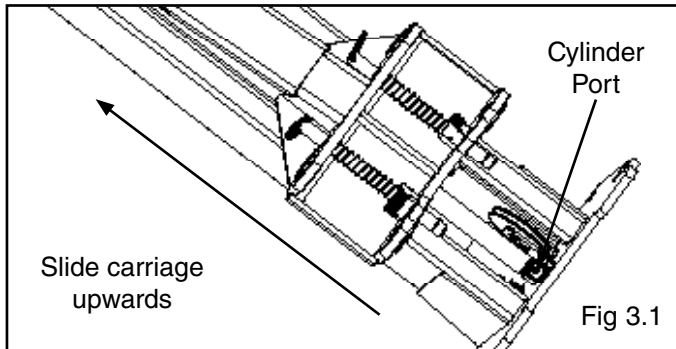

2. Install a 1/4" NPT straight fitting into each cylinder port using teflon tape then temporarily remove the cable sheaves located at the inside bottom of each Column by first removing the hex head bolts, and then by removing the sheave pin. (See Fig 3.2)

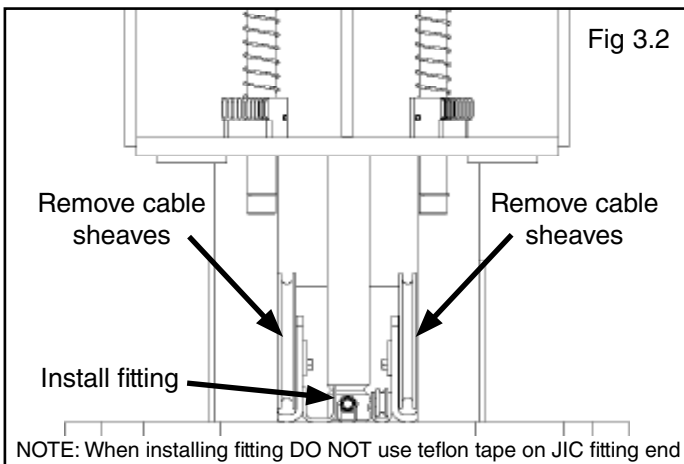

3. Route button end of the cable upwards through the bottom of the carriage and wrap the cable around the cable sheave and reinstall sheave by reversing the sheave removal procedure. Leave excess cable tied together in a coil to carriage until further steps are required. (See Fig 3.3 & 3.4)

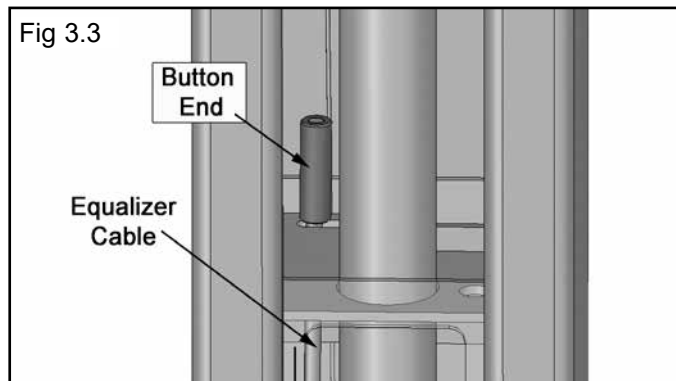

NOTE:
 REFER TO STEP 10 FOR CABLE ROUTING DETAILS.
 ROUTE BUTTON END OF CABLES PRIOR TO
 RAISING UP THE POSTS.

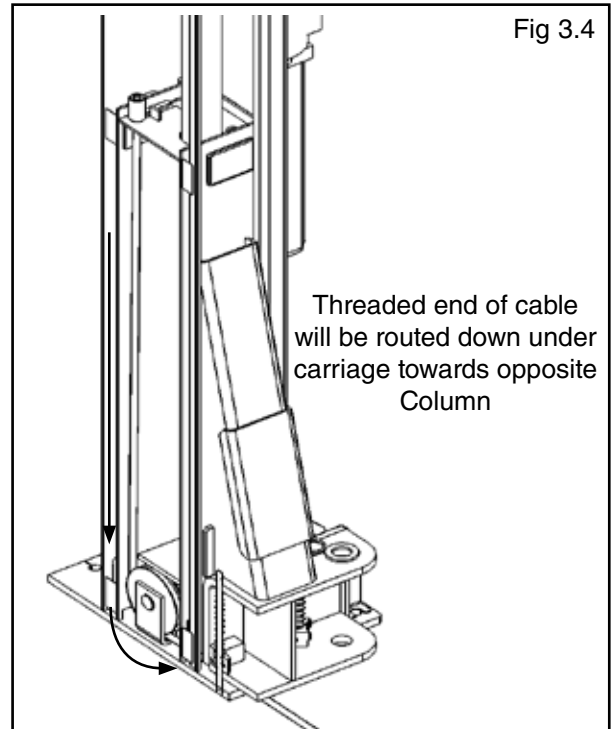

NOTE: Portions of Carriage and Column cut away for clarity

4. To install optional sheave covers, place sheave cover on sheave bracket so that the bracket return faces towards the sheave and align pin holes and bolt holes. The cutout in the bracket for the cable must be facing towards the base plate. Insert pin through sheave cover, sheave bracket, and sheave. Align pin bolt hole with sheave cover bolt hole and sheave bracket bolt hole and insert M6 hex head bolt and tighten. (See Fig 3.5)

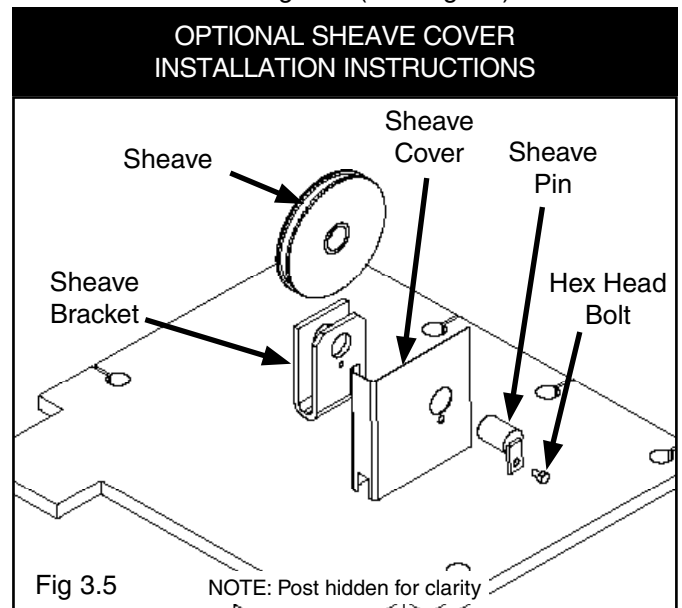

SITE LAYOUT / FLOOR PLAN

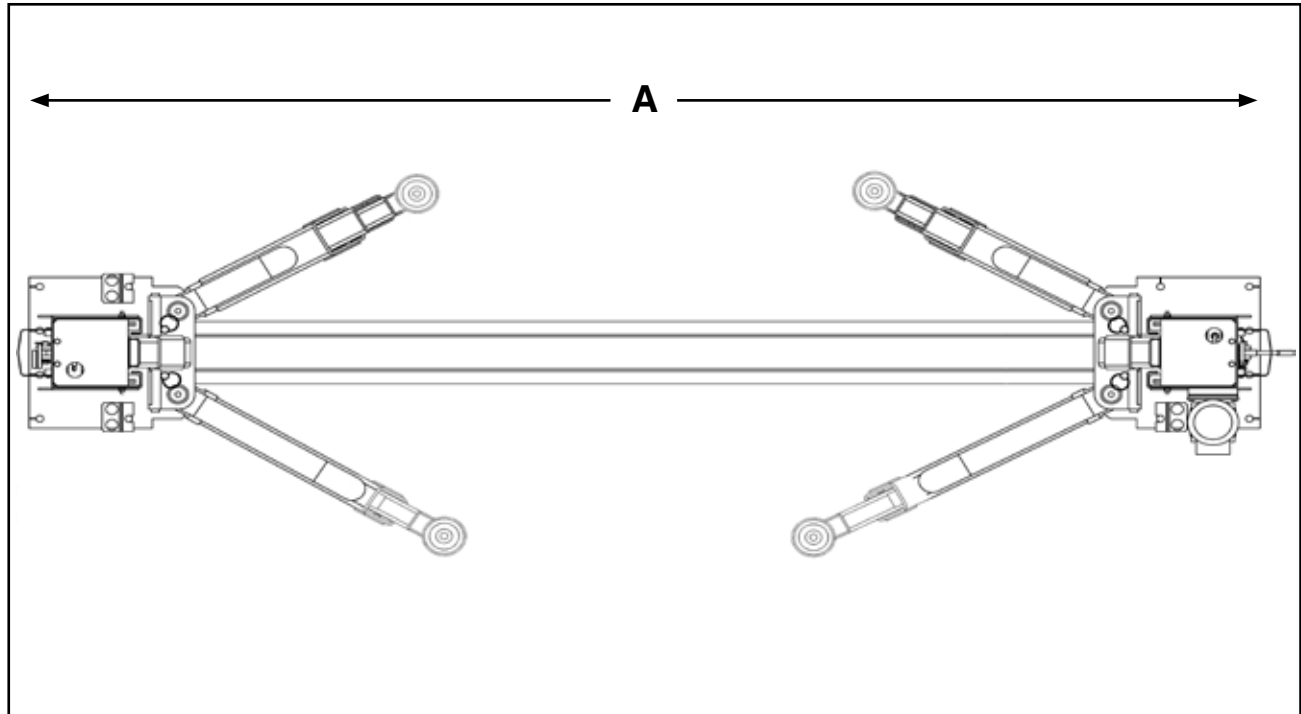

Model	A	Capacity
XPR-12FDL	155" / 3937 mm	12,000 LBS

STEP 4 (Site Layout)

1. Determine which side of the lift will be the approach side.
2. Now determine where the power unit will be located. The POWER SIDE column has the power unit mounting bracket attached to the side.
3. Use the chart on this page to determine which lift width layout you would like to use.
4. Once a location is determined, use a carpenter's chalk line to layout a grid for the Column locations. Keep all dimensions square within 1/8" (3mm) or malfunctioning of the lift can occur.
5. After the Column locations are properly marked, use chalk or crayon to make an outline of the posts on the floor at each Column location using the Column base plates as a template. (See Fig 4.1)
6. **CHECK ALL DIMENSIONS TWICE** and make sure that the layout is perfectly square.

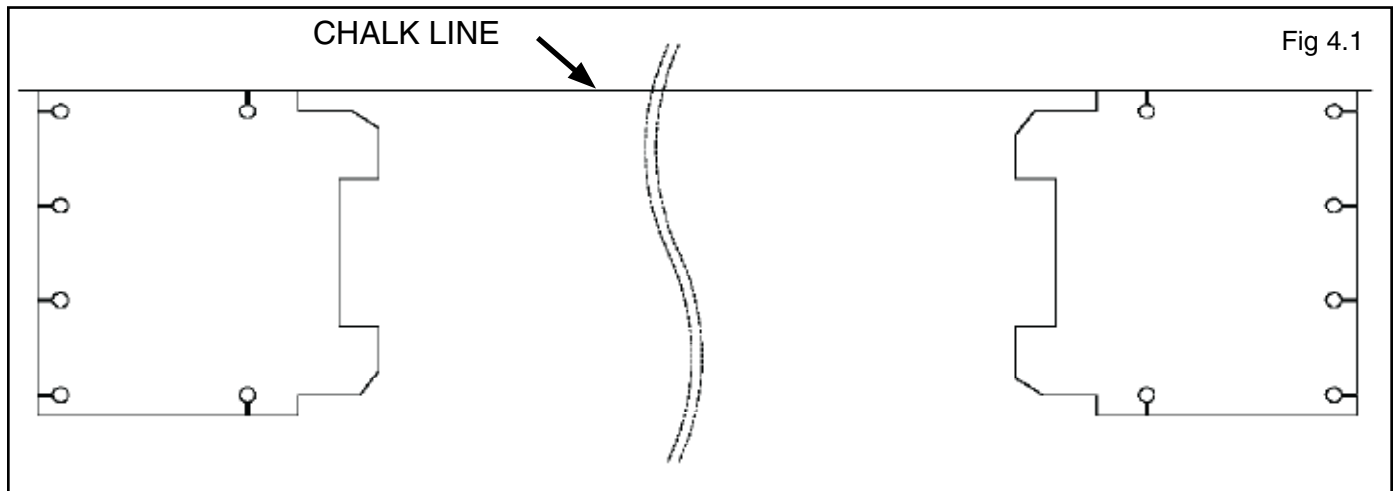

STEP 5 (Installing the POWER SIDE Column)

1. Before proceeding, double the check measurements and make certain that the base plate of each Column is aligned with the chalk line.

NOTE:

BENDPAK LIFTS ARE SUPPLIED WITH INSTALLATION INSTRUCTIONS AND CONCRETE FASTENERS MEETING THE CRITERIA AS PRESCRIBED BY THE AMERICAN NATIONAL STANDARD "AUTOMOTIVE LIFTS - SAFETY REQUIREMENTS FOR CONSTRUCTION, TESTING, AND VALIDATION" ANSI/ALI ALCTV-2011. LIFT BUYERS ARE RESPONSIBLE FOR ANY SPECIAL REGIONAL STRUCTURAL AND/OR SEISMIC ANCHORING REQUIREMENTS SPECIFIED BY ANY OTHER AGENCIES AND/OR CODES SUCH AS THE UNIFORM BUILDING CODE (UBC) AND/OR INTERNATIONAL BUILDING CODE (IBC).

2. Using the base plate on the POWER SIDE Column as a guide, drill each anchor hole in the concrete approximately 6" deep for 12K using a rotary hammer drill and 3/4" concrete drill-bit. To ensure full holding power, do not ream the hole or allow the drill to wobble. (See Fig. 5.1)

3. After drilling, remove dust thoroughly from each hole making certain that the posts remain aligned with the chalk line.

4. Assemble the washers and nuts on the anchors then tap into each hole with a hammer until the washer rests against the base plate. If shimming is required be sure that enough threads are left exposed. (See Fig. 5.2)

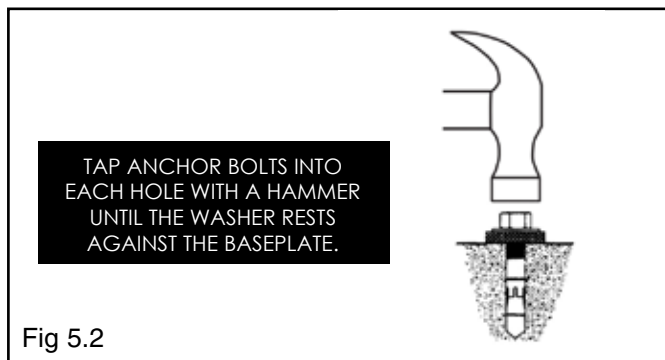
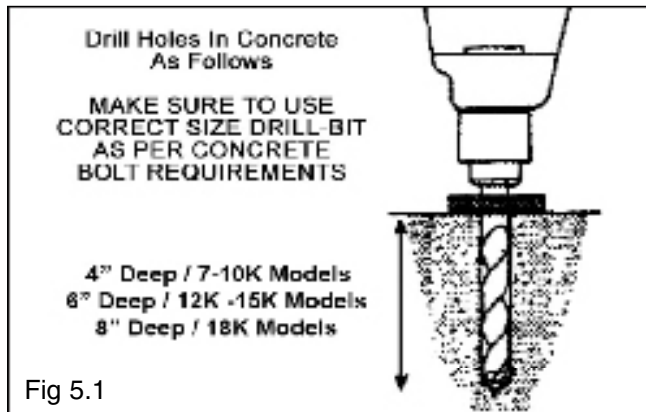

5. If shimming is required, insert the shims as necessary under the base plate so that when the anchor bolts are tightened, the posts will be plumb.

6. With the shims and anchor bolts in place, tighten by securing the nut to the base then turning 3-5 full turns clockwise. **DO NOT** use an impact wrench for this procedure. (See Fig. 5.3)

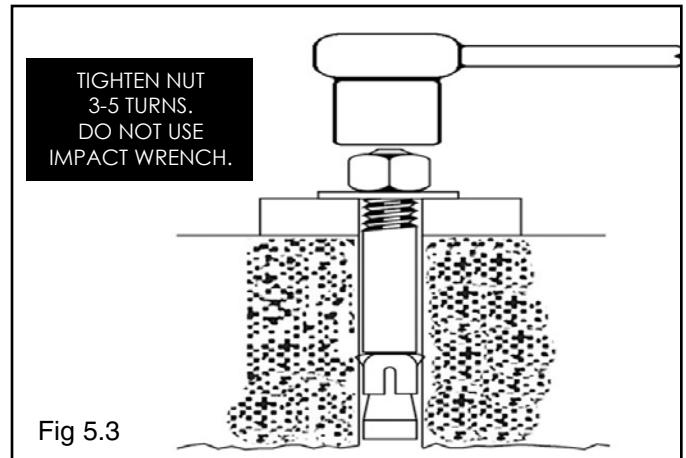

STEP 6 (Installing the OFF SIDE Column)

1. Position the OFF SIDE Column at the designated chalk locations and secure Column to floor following the same procedures as outlined in STEP 5; Paragraphs 1-6.

NOTE:

TO EASE THE INSTALLATION OF THE OVERHEAD ASSEMBLY, IT HELPS TO KEEP THE ANCHOR BOLTS LOOSE ON ONE OF THE POSTS UNTIL THE OVERHEAD ASSEMBLY IS MOUNTED.

STEP 7 (Mounting the Hydraulic Power Unit)

1. Attach the power unit to the POWER SIDE Column. Install the vibration dampener between the power unit and the power unit mounting plate on the Power Side Column, using four M8 hex head bolts and nuts supplied. (See Fig 7.1)

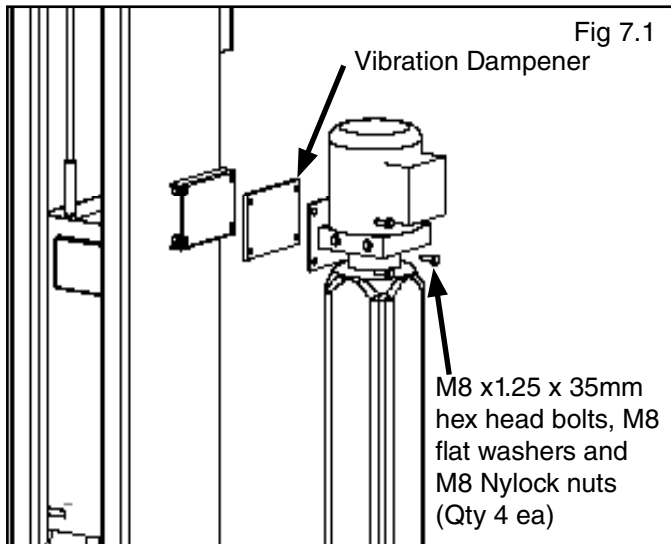

2. Fill the reservoir with 10 WT. HYDRAULIC OIL OR DEXRON TYPE III ATF, approximately four gallons. Make sure the funnel used to fill the Power Unit is clean.

Do not connect power unit hydraulic hose assembly at this time.

3. The standard power unit for your lift is 220 volt, 60HZ, single phase. All wiring must be performed by a certified electrician only. SEE WIRING INSTRUCTIONS AFFIXED TO MOTOR FOR PROPER WIRING INSTRUCTIONS.



ALL WIRING MUST BE PERFORMED BY A LICENSED ELECTRICIAN.



DO NOT PERFORM ANY MAINTENANCE OR INSTALLATION OF ANY COMPONENTS WITHOUT FIRST ENSURING THAT ELECTRICAL POWER HAS BEEN DISCONNECTED AT THE SOURCE OR PANEL AND CANNOT BE RE-ENERGIZED UNTIL ALL MAINTENANCE AND/OR INSTALLATION PROCEDURES ARE COMPLETED.



DO NOT RUN POWER UNIT WITHOUT OIL. DAMAGE TO POWER UNIT PUMP CAN OCCUR. THE POWER UNIT MUST BE KEPT DRY. DAMAGE TO POWER UNIT CAUSED BY WATER OR OTHER LIQUIDS SUCH AS DETERGENTS, ACID ETC., IS NOT COVERED UNDER WARRANTY.

OPERATE LIFT ONLY BETWEEN TEMPERATURES OF 41° - 104° F. IMPROPER ELECTRICAL HOOK-UP CAN DAMAGE MOTOR AND WILL NOT BE COVERED UNDER WARRANTY. MOTOR CAN NOT RUN ON 50HZ WITHOUT A PHYSICAL CHANGE IN THE MOTOR.

USE A SEPARATE CIRCUIT BREAKER FOR EACH POWER UNIT. PROTECT EACH CIRCUIT WITH TIME DELAY FUSE OR CIRCUIT BREAKER.

FOR 208-230 VOLT, SINGLE PHASE, USE A 25 AMP FUSE. FOR 208-230 VOLT, THREE PHASE, USE A 20 AMP FUSE. FOR 380-440 VOLT, THREE PHASE, USE A 15 AMP FUSE.

STEP 8 (Installing the Safeties and Safety Cable)

1. Install safety weldments on to each respective Column. (See Figs 8.1 - 8.2)

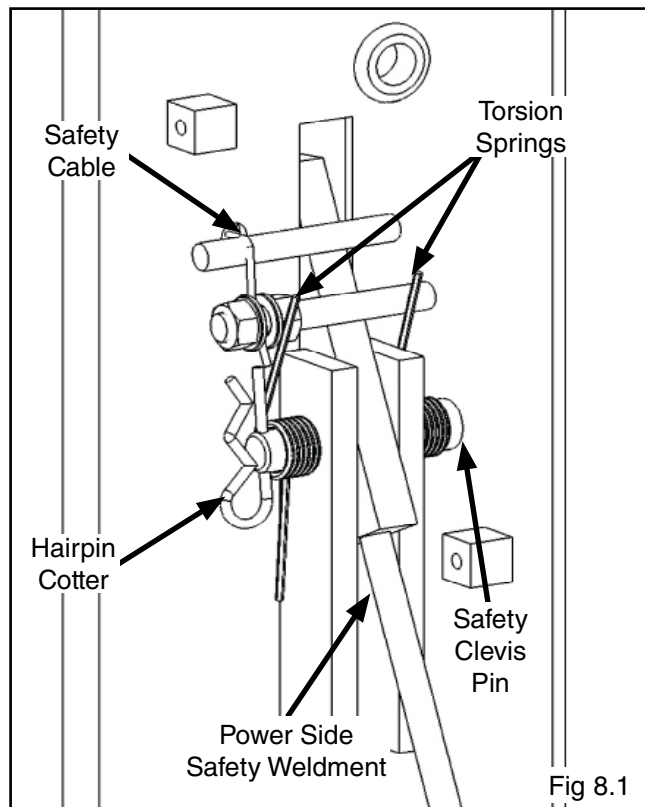

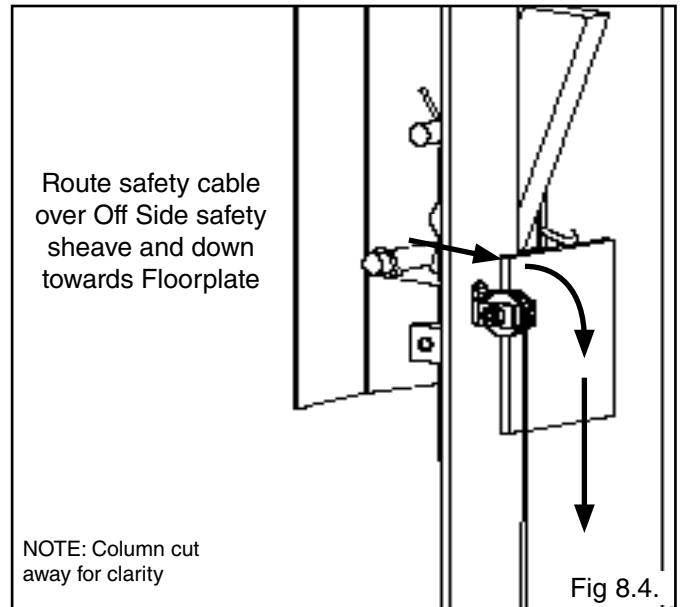
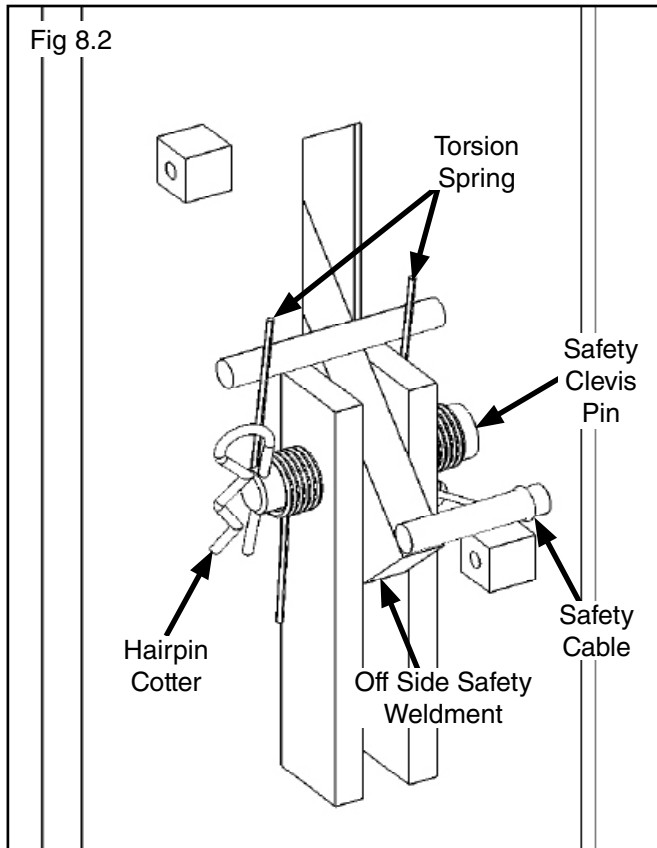

2. From the Off Side Column insert the non-looped end of the safety cable through the hole located to the right of the Off Side safety weldment. (See Fig 8.3)

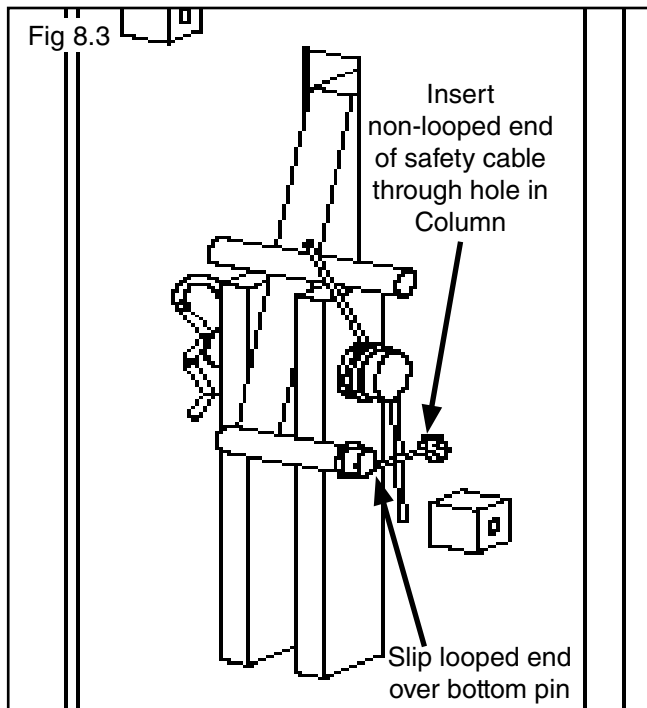
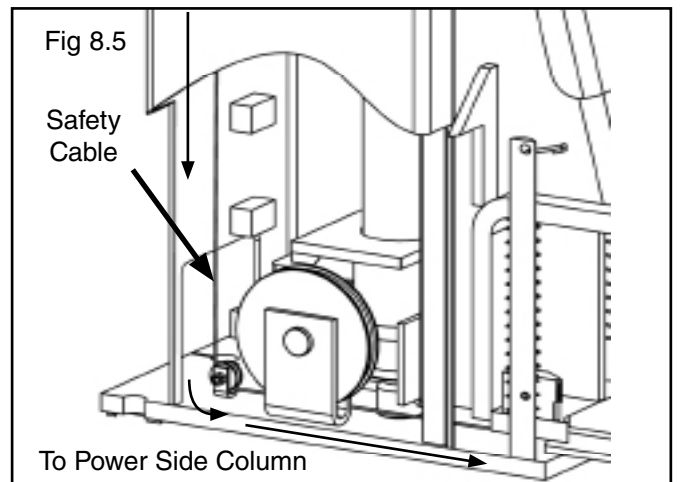

3. Route the cable over the sheave and route it towards the baseplate safety sheave. (See Fig 8.4)

4. Route the cable through the baseplate's safety sheave(s) and across the floor towards the Power Side Column. (See Fig 8.5 - 8.6)

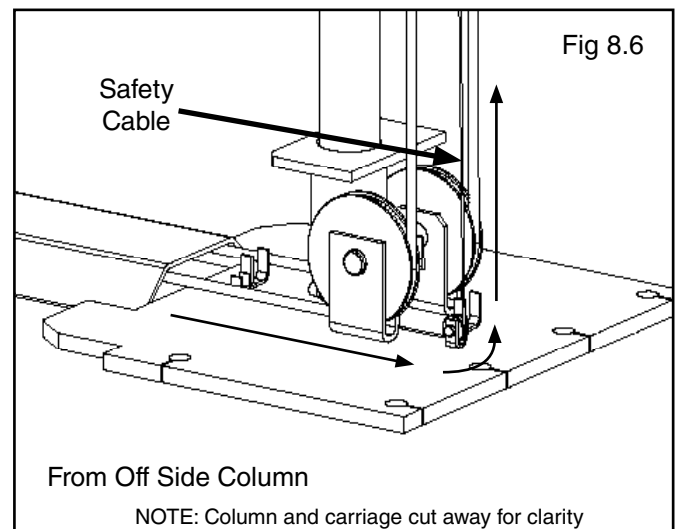

5. Route the cable the same way as on the Power Side going up the Column and over the safety cable sheave.

6. Route the cable over the top pin on the safety handle. Insert the cable end through the hole on the threaded pin. (See Fig 8.7)

7. Pull the slack out the safety cable and keep tension on the cable as nuts are being tightened. Tighten jam nuts on either side of the cable keeping the cable centered to the hole to secure it into place. (See Fig 8.7)

NOTE:
MAKE SURE TO KEEP THE SAFETY CABLE CENTERED WHEN TIGHTENING JAM NUTS ON SAFETY.

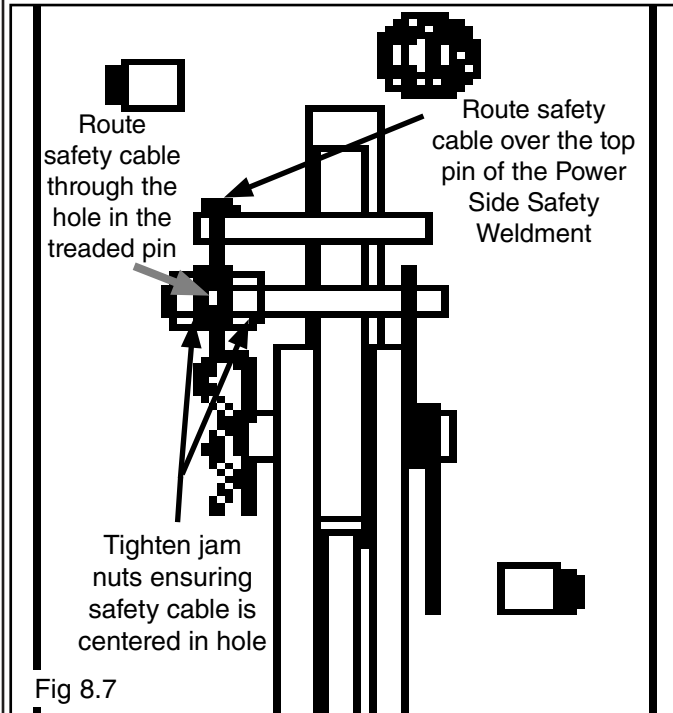

! DANGER

ENSURE THAT BOTH THE POWER SIDE & OFF SIDE SAFETIES ENGAGE PROPERLY PRIOR TO LIFT OPERATION.

8. Operate the power side safety handle, check for proper operation of both Safety Assemblies and adjust cable tension as required.

9. Raise and lock each carriage approximately 28" above the ground. (See Fig. 8.8)

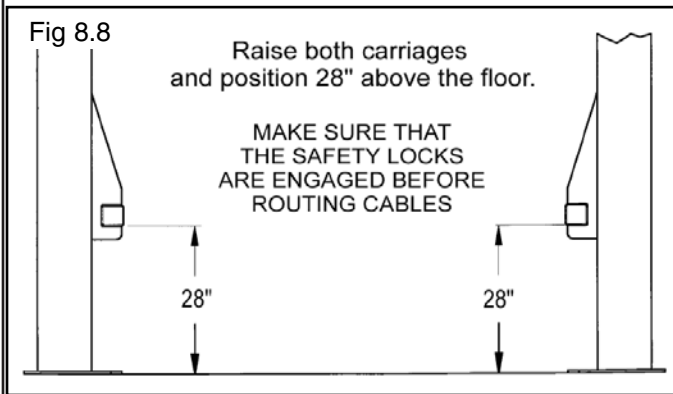

STEP 9 (Installing Hydraulic Lines)

NOTE:
FOR THE WIDE CONFIGURATION, A 13" EXTENSION MUST BE INSTALLED TO THE CROSSOVER HOSE. A JIC TO JIC STRAIGHT FITTING HAS BEEN PROVIDED TO CONNECT THE CROSSOVER HOSE TO THE EXTENSION HOSE IN THE PARTS BOX.

1. Connect the two cylinder hydraulic hoses in line to the tee fitting. Connect the 90° fitting to the tee fitting. Connect the power unit hose to the 90° fitting. (See Fig 9.1)

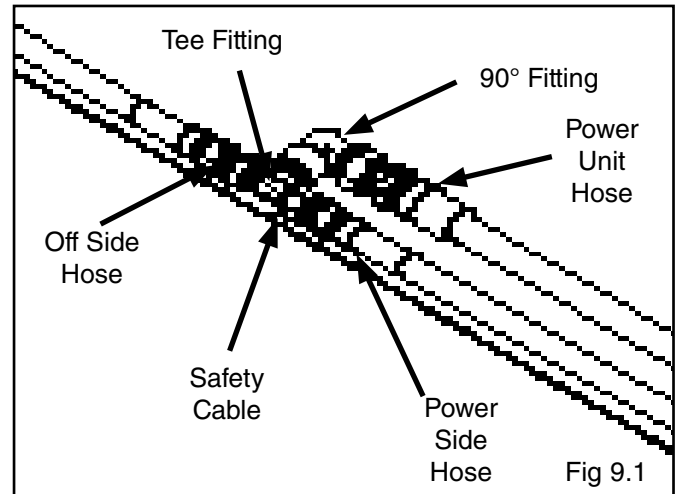

2. Connect the cylinder hoses to the straight fittings on the cylinders. DO NOT use teflon tape on the JIC fitting end. (See Fig 9.2)

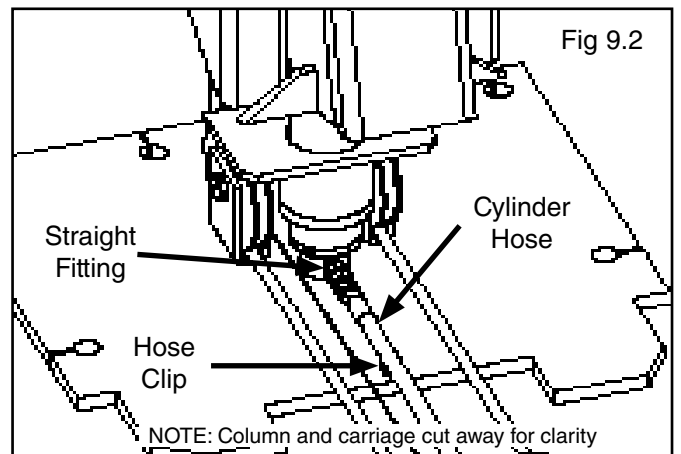

3. Route the power unit hose between the cylinder shaft and the equalizer sheave bracket. Route the hose through the hose clip. Failure to do so may cause damage or injury. (See Fig 9.3)

4. Remove the plastic plug from the power unit power port. Install the 90° power unit fitting with O-ring using teflon tape. (Connect the power unit hose assembly to the 90° hydraulic fitting on the power unit. DO NOT use teflon tape on the JIC hose fittings. (See Fig 9.4)

! WARNING

WHEN ROUTING HYDRAULIC HOSES THROUGH THE POSTS, ROUTE HOSES THROUGH THE HOSE CLIPS WELDED ON EACH POST. MAKE SURE THAT THE HOSE IS CLEAR OF ANY MOVING PARTS. IT MAY BE NECESSARY TO TIE THE HOSES CLEAR BY USING NYLON TIE STRAPS OR WIRE. FAILURE TO KEEP THE HYDRAULIC HOSES CLEAR MAY RESULT IN THE HYDRAULIC HOSES TO FAIL, WHICH MAY RESULT IN DAMAGE OR PERSONAL HARM.

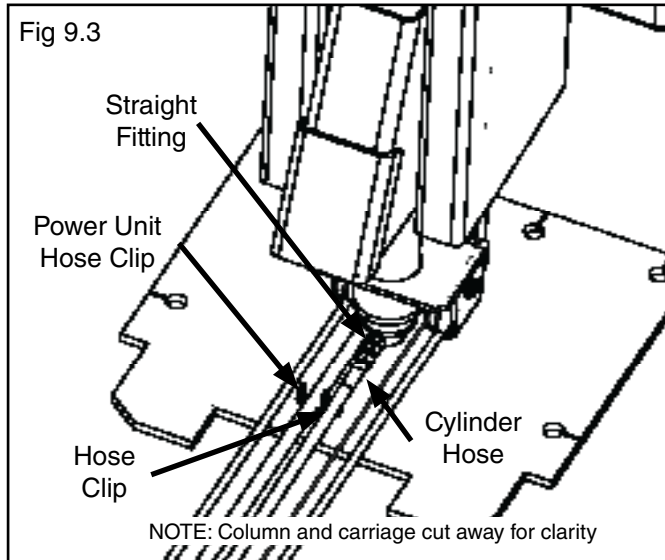

NOTE:
POWER PORT LOCATION IN HYDRAULIC POWER UNIT MAY VARY. CONFIRM THE LOCATION OF THE POWER PORT ENCLOSED IN THE POWER UNIT DOCUMENTATION.

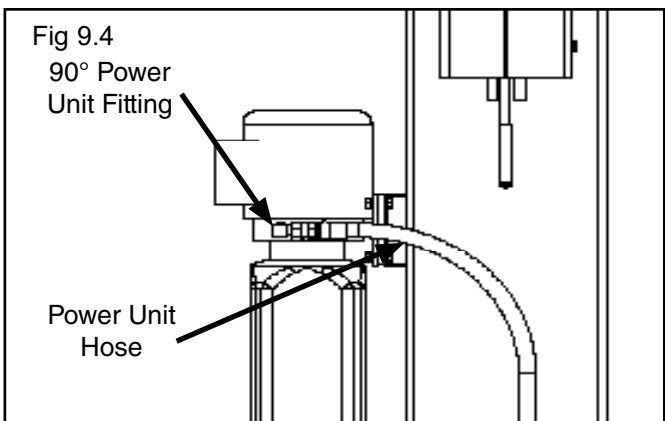

**STEP 10
(Routing the Equalizer Cables)**

Refer to illustrations on Page 17.

1. Raise and lock each carriage approximately 28" above the ground. (See Fig. 10.1)

! DANGER

MAKE SURE THAT THE SAFETY LOCKS ON EACH POST ARE FULLY ENGAGED BEFORE ATTEMPTING TO ROUTE EQUALIZER CABLES AND/OR HOSES. CARRIAGES MUST BE EQUAL HEIGHT FROM THE FLOOR BEFORE PROCEEDING.

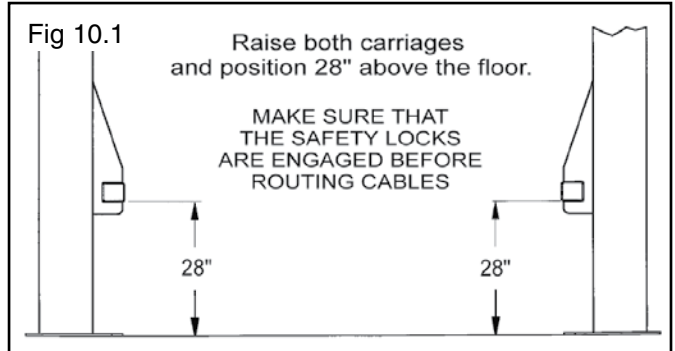

2. With the carriages locked at 28" off the floor, route the threaded end of the equalizer cable across to the opposite side base plate sheave and up through the carriage. (See Fig. 10.2)

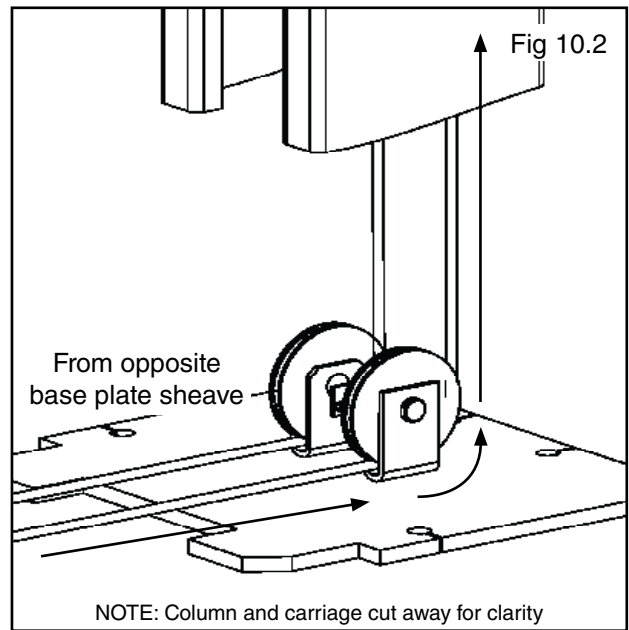

3. Route the threaded end up and over the Top Plate sheave and back down to the carriage and reinstall sheave. (See Fig. 10.3)

NOTE:
THERE WILL BE INITIAL STRETCHING OF THE CABLES AND/OR WITH INCREASED LOADS. ADJUST THE CABLES AS OUTLINED ABOVE A WEEK AFTER FIRST USE, THEN EVERY THREE TO SIX MONTHS THEREAFTER DEPENDING ON USAGE AND/OR TO COMPENSATE FOR STRETCH.

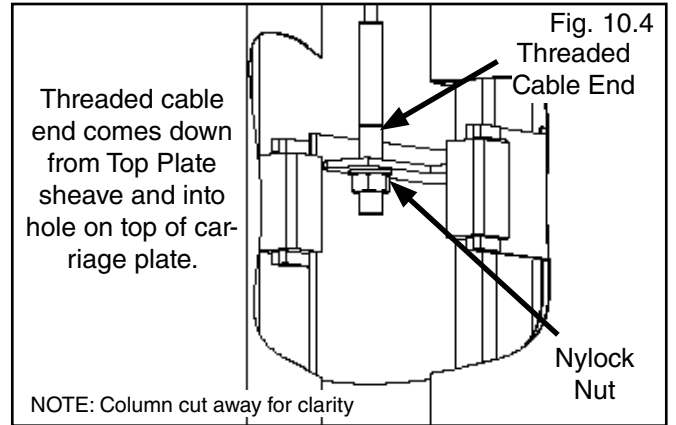
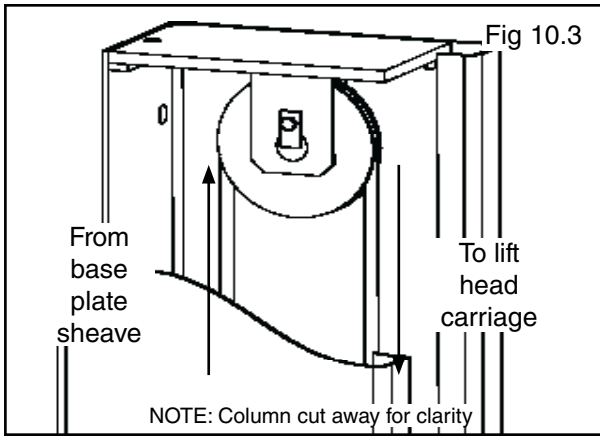

4. Insert the threaded end of the cable through the hole on top of the carriage. Place M18 washer and M18 Nylon nut on threaded cable end. Tighten cable nuts until taut, checking that both cables have equal tension. (See Fig 10.4)



THE EQUALIZER CABLE SHEAVES WILL NEED TO BE REMOVED TO EASE THE ROUTING OF THE EQUALIZER CABLES. BE SURE TO REINSTALL ALL PINS, COVERS, BOLTS AND CLIPS OR SERIOUS DAMAGE OR INJURY MAY OCCUR.



WHEN THE CABLE ADJUSTING NUTS BOTTOM OUT ON THE THREADED END OF THE CABLE CONNECTOR AND THERE IS STILL SLACK IN THE CABLES, THE CABLES HAVE STRETCHED BEYOND THE SAFE USEFUL LENGTH AND NEED TO BE REPLACED WITH FACTORY APPROVED CABLE ASSEMBLIES. DO NOT PLACE WASHERS, SPACERS OR OTHER DEVICES TO "SHORTEN" THE EFFECTIVE CABLE LENGTH AS DAMAGE TO THE LIFT OR INJURY TO PERSONS MAY OCCUR.

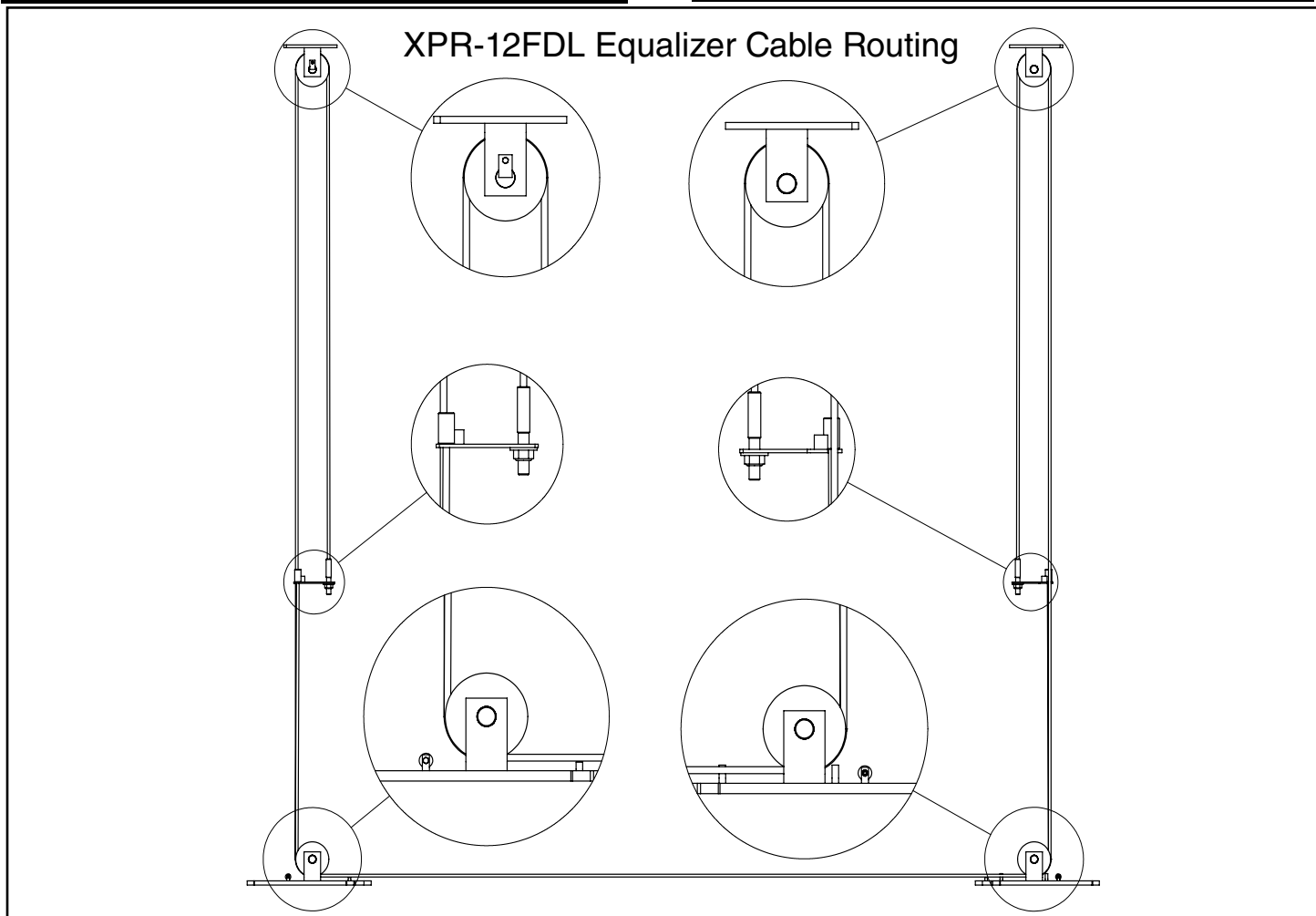

STEP 11 (Installing Floor Plate and Safety Cover)

1. After safeties have been adjusted and checked for proper operation, install and tighten Power Side safety cover and Off Side safety cover mounting screws. (See Fig. 11.1)

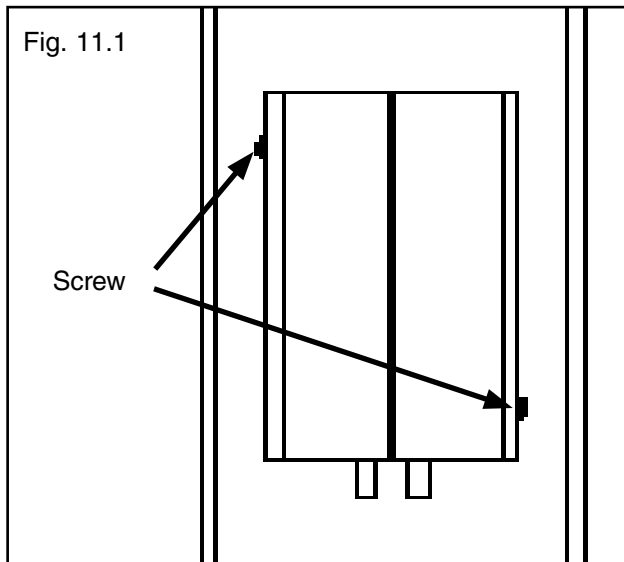

2. Install the floor plate between the columns as shown. (See Fig. 11.2)

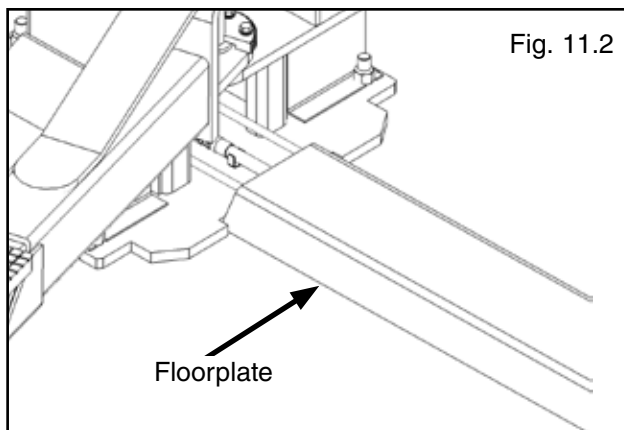

STEP 12 (Installing the Lift Arms)

1. Place the lift arm assemblies in the lift heads.
2. Install the lift head pins into the lift head and through the holes in the arm assembly. (See Fig. 12.1)
3. Install the snap ring into the groove in the lift head pin on under side of the lift head. (See Fig. 12.2)
4. Place each Gear Ring against the Lift Head Pin and align the holes in the Gear Ring with the threaded holes in the Arm Ears. Ensure that the teeth on the Gear Ring mesh smoothly with the teeth on the gears of the Lift Head. (See Fig. 12.3)

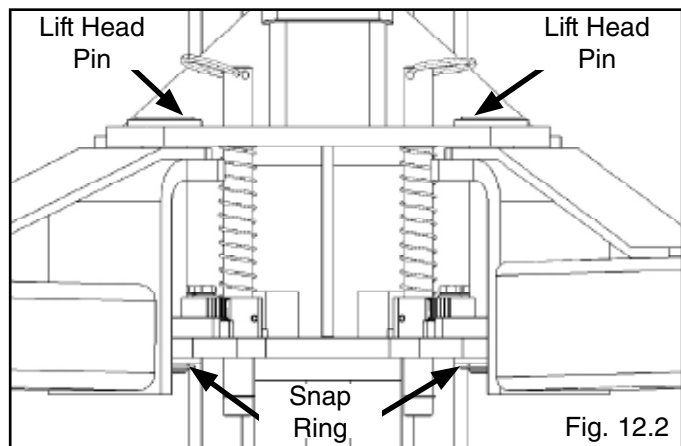
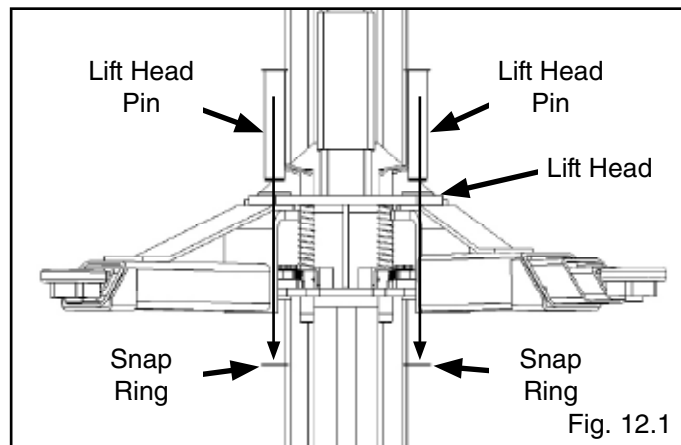

THE ARM RESTRAINT GEARS MUST BE POSITIONED PROPERLY. CONFIRMATION OF PROPER GEAR ENGAGEMENT MUST BE MADE PRIOR TO THE OPERATION OF THE LIFT. PERIODIC INSPECTION IS REQUIRED. FAILURE TO INSPECT THE ARM RESTRAINT GEARS ON ALL FOUR ARMS PROPERLY CAN RESULT IN DAMAGE TO THE VEHICLE OR INJURY AND/OR DEATH.

5. Verify the operation of the arm restraints by pulling up on the key ring of the arm restraint pin. Pivot the arms back and forth and test the operation of the arm restraint pin in various positions. (See Fig. 12.4)

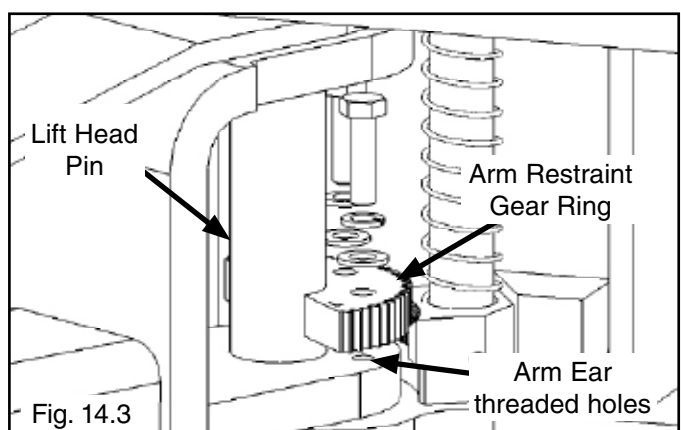

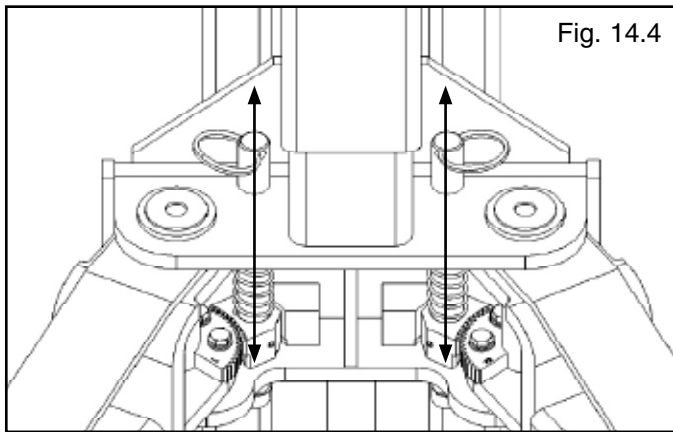

6. Ensure that the arms do not move when a force of approximately 100 pounds or less is applied laterally to the fully extended arms.



NOTE:
 EACH ARM RESTRAINT ASSEMBLY MUST BE INSPECTED BEFORE EACH AND EVERY TIME THE LIFT IS OPERATED.

DO NOT OPERATE THE LIFT IF ANY OF THE FOUR ARM RESTRAINT SYSTEMS ARE NOT FUNCTIONING PROPERLY.

REPLACE BROKEN COMPONENTS OR COMPONENTS WITH BROKEN TEETH ONLY WITH AUTHORIZED OR APPROVED REPLACEMENT PARTS.

WARNING

IMPORTANT LEVELING INSTRUCTIONS

Before operating your lift, check to make sure that both "A" and "B" measurements are EQUAL.

The lift arms must be level before operation.

If your lift arms are not level, shim the columns as required.

IMPORTANT NOTE:
 The equalizer cables should be checked weekly for equal tension. Failure to do this will cause uneven lifting. The cables should always be adjusted so that they are equal tension when resting on the safety locks.

CARRIAGE STOP BOLT INSTALLATION WARNING



YOU MUST RE-INSTALL TOP CARRIAGE-STOP BOLT (SHOWN BELOW). TIGHTEN CARRIAGE-STOP BOLT TO 2-3 FT.-LBS. OF TORQUE UPON FINAL INSTALLATION INSPECTION. THESE INSTRUCTIONS MUST BE FOLLOWED TO ENSURE PROPER INSTALLATION AND OPERATION OF YOUR LIFT. FAILURE TO COMPLY WITH THESE INSTRUCTIONS CAN RESULT IN SERIOUS BODILY INJURY AND/OR DEATH AND/OR VOID PRODUCT WARRANTY. MANUFACTURER WILL ASSUME NO LIABILITY FOR LOSS OR DAMAGE OF ANY KIND, EXPRESSED OR IMPLIED RESULTING FROM IMPROPER INSTALLATION OR USE OF THIS PRODUCT.

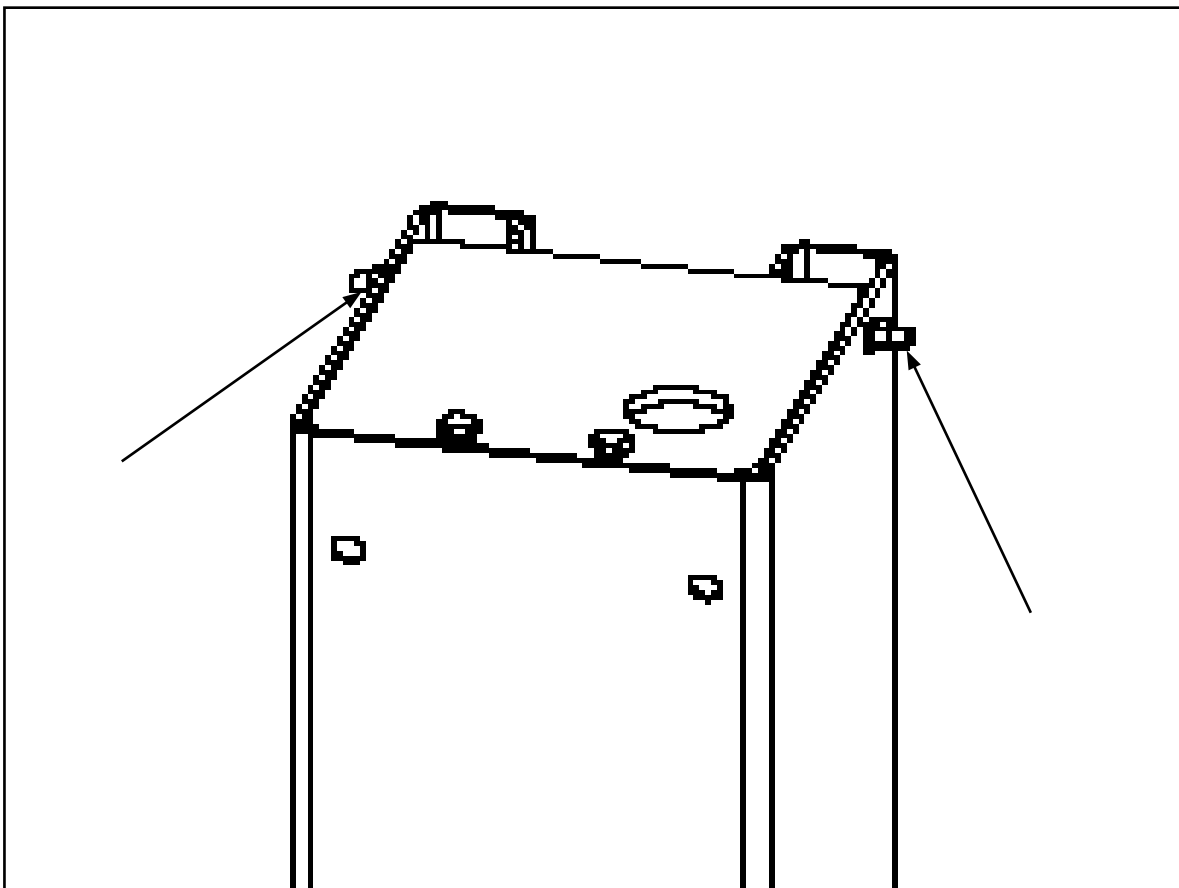



DO NOT PERFORM ANY MAINTENANCE OR INSTALLATION OF ANY COMPONENTS WITHOUT FIRST ENSURING THAT ELECTRICAL POWER HAS BEEN DISCONNECTED AT THE SOURCE OR PANEL AND CANNOT BE RE-ENERGIZED UNTIL ALL MAINTENANCE AND/OR INSTALLATION PROCEDURES ARE COMPLETED.



IMPORTANT POWER-UNIT INSTALLATION NOTES

- DO NOT run power unit without oil. Damage to pump can occur.
- The power unit must be kept dry. Damage to power unit caused by water or other liquids such as detergents, acid etc., is not covered under warranty.
- Improper electrical connection can damage motor and will not be covered under warranty.
- Motor can not run on 50HZ without a physical change in the motor.
- Use a separate breaker for each power unit.
- Protect each circuit with time delay fuse or circuit breaker.
- For 208-230 volt, single phase, use a 25 amp fuse.
- For 208-230 volt, three phase, use a 20 amp fuse.
- For 380-440 volt, three phase, use a 15 amp fuse.

Installation and adjustment.

DO NOT attempt to raise vehicle until a thorough operation check has been completed.

ALL WIRING MUST BE PERFORMED BY A CERTIFIED ELECTRICIAN ONLY.

Single Phase

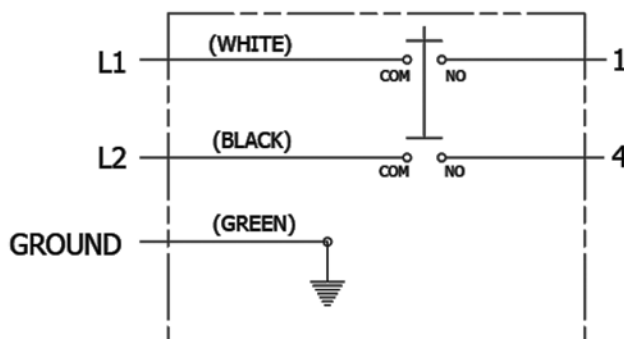

Three Phase

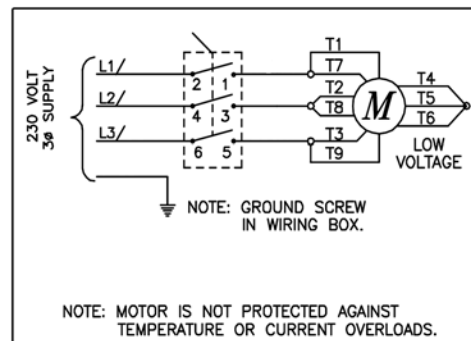

**SEE WIRING INSTRUCTIONS AFFIXED TO
MOTOR FOR PROPER WIRING INSTRUCTIONS.**

STEP 13 (Power Unit Connection)

1. Have a certified electrician run the power supply to motor. Refer to the data plate found on the motor for proper power supply and wire size.



RISK OF EXPLOSION

This equipment has internal arcing or parts that may spark and should not be exposed to flammable vapors. Motor should not be located in a recessed area or below floor level. NEVER expose motor to rain or other damp environments. **DAMAGE TO MOTOR CAUSED BY WATER IS NOT COVERED UNDER WARRANTY.**

NOTE:

CAUTION NEVER OPERATE THE MOTOR ON LINE VOLTAGE LESS THAN 208V. MOTOR DAMAGE MAY OCCUR WHICH IS NOT COVERED UNDER WARRANTY. HAVE A CERTIFIED ELECTRICIAN RUN APPROPRIATE POWER SUPPLY TO MOTOR. SIZE WIRE FOR 25 AMP CIRCUIT. SEE MOTOR OPERATING DATA TABLE. USE SEPARATE CIRCUIT FOR EACH POWER UNIT. PROTECT EACH CIRCUIT WITH TIME DELAY FUSE OR CIRCUIT BREAKER. FOR SINGLE PHASE 208-230V, USE 25 AMP FUSE. THREE PHASE 208-240V, USE 25 AMP FUSE. FOR THREE PHASE 400V AND ABOVE, USE 15 AMP FUSE. ALL WIRING MUST COMPLY WITH NECK AND ALL LOCAL ELECTRICAL CODES.

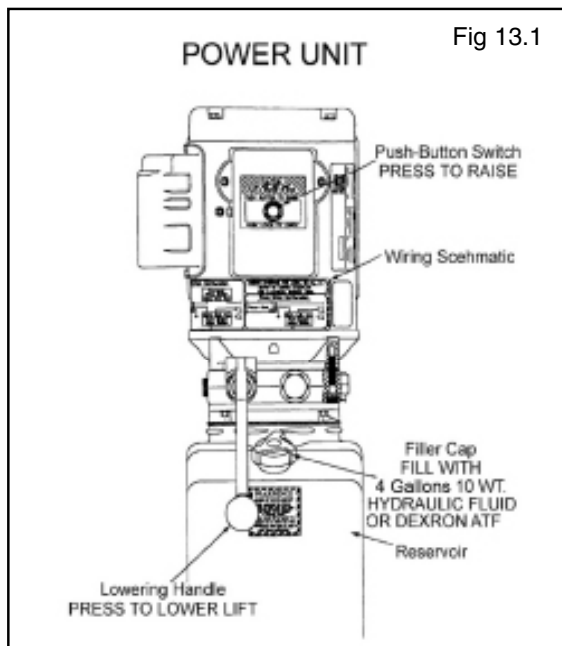

STEP 14 (Lift Start Up / Final Adjustments)



DURING THE START-UP PROCEDURE, OBSERVE ALL OPERATING COMPONENTS AND CHECK FOR PROPER INSTALLATION AND ADJUSTMENT. DO NOT ATTEMPT TO RAISE VEHICLE UNTIL A THOROUGH OPERATIONAL CHECK HAS BEEN COMPLETED.

1. Make sure the power unit reservoir is full with four (4) gallons of 10-WT hydraulic oil or Dexron-III automatic transmission fluid.
2. Apply light axle grease to the inside of the posts where the slide blocks glide.
3. Test the power unit by pressing the push-button switch. If the motor sounds like it is operating properly, raise the lift and check all hose connections for leaks. If the motor gets hot or sounds peculiar, stop and check all electrical connections.
4. Before proceeding, double-check to make sure all cables are properly positioned within the grooves of ALL sheaves. Make sure all cable sheave retaining pins and/or clips are secure.
5. Check to make sure that all safety locks are cleared and free.
6. Continue to press the button to raise lift until the cables get taut and the lift starts to move.
7. **KEEP HANDS AND FEET CLEAR.** Remove hands and feet from any moving parts. Keep feet clear of lift when lowering. Avoid pinch points.
8. Check all MAIN SAFETY LOCKS to make sure they move freely and spring back to the lock position when released. Lubricate all SAFETY PIVOT points with light spray-oil.
9. Cycle the lift up and down a few times to ensure that the safety locks are engaging uniformly and that the safety release mechanisms are functioning. Re-adjust if necessary.

POST-INSTALLATION CHECK-OFF

- Columns properly shimmed and stable
- Anchor Bolts tightened
- Pivot / Sheave Pins properly attached
- Electric power supply confirmed
- Cables adjusted properly
- Safety Locks functioning properly
- Check for hydraulic leaks
- Oil level
- Lubrication of critical components
- Check for overhead obstructions
- All Screws, Bolts, and Pins securely fastened
- Surrounding area clean
- Operation, Maintenance and Safety Manuals on site.
- Perform an Operational Test with a typical vehicle

STEP 15 (Lubrication)

1. After installation and start-up has been completed, lubricate lift components as described below.
(See Fig. 15.1)

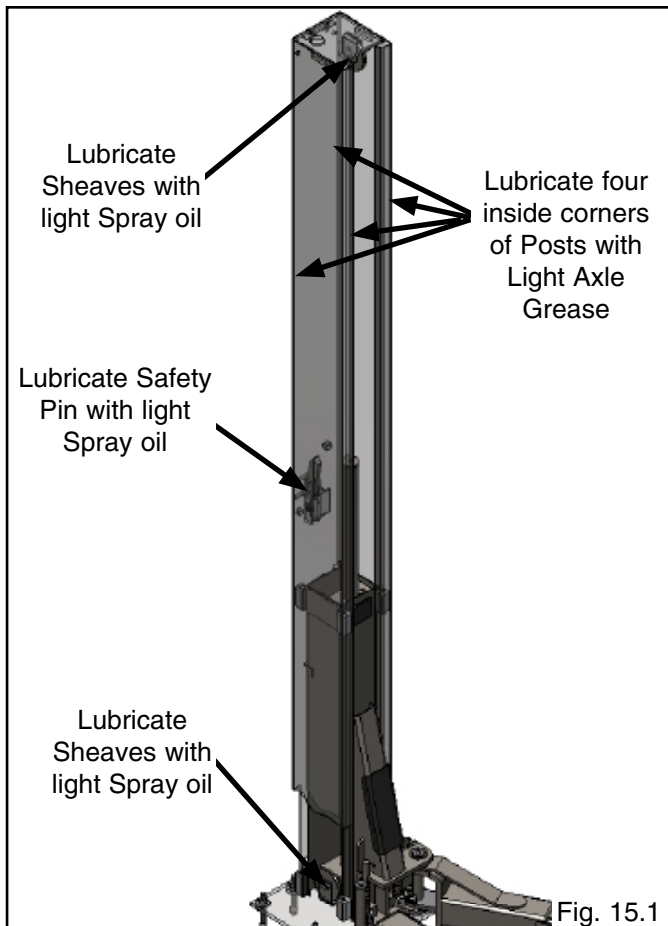

STEP 16 (Bleeding the Cylinders)



THE LIFT WILL MOVE DOWN WHEN BLEEDING. MAKE SURE ALL EQUIPMENT, PERSONNEL, HANDS AND FEET ARE CLEAR BEFORE PERFORMING THE CYLINDERS BLEEDING.

1. After electrical power is connected and oil reservoir is full, press button to raise lift.
2. Continue raising until lift cylinders fully extend to full height. DO NOT continue pressing button after lift reaches full height. Damage to motor can occur if continued.
3. Lower the lift only HALF WAY by pressing the SAFETY RELEASE handle inward then pressing in the DOWN lever on the power unit.
4. With the lift at half height, slowly loosen the BLEED SCREWS located at the top of each cylinder to bleed trapped air. DO NOT completely remove bleed screws. Re-tighten after trapped air has escaped. (See Fig. 16.1)
5. Lower the lift completely by pressing the SAFETY RELEASE handle inward then pressing the DOWN lever on power unit. Wait five minutes and repeat bleeding process one additional time.

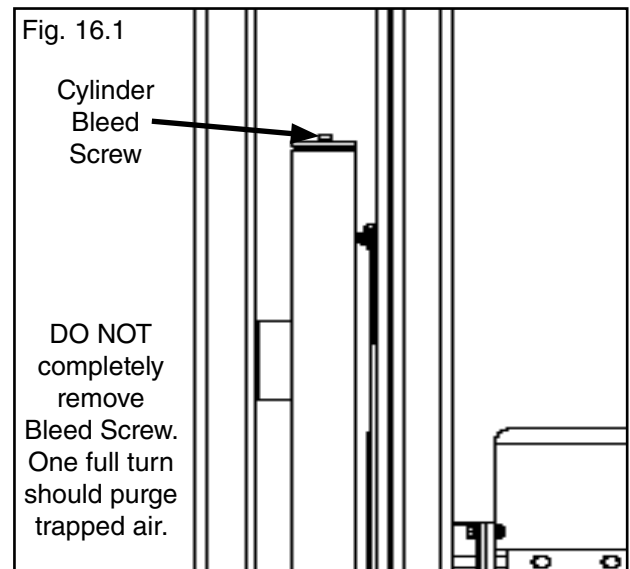

OPTIONAL EQUIPMENT INSTALLATION

- ☑ Included Standard
- ⊗ Not Included / Optional



Model No.	44mm. Adapter	63mm. Adapter	125mm. Adapter	Telescoping Screw Pad	Standard Pad	Frame Cradle Pads
XPR-12FDL	⊗	☑	☑	⊗	☑	☑
XPR-12FDL-LWB	⊗	☑	☑	⊗	☑	☑



Telescoping Screw Pad (Optional)



Frame Cradle Pad

⚠ DANGER

SKU# 5715016

FRAME CRADLE CONTACT PADS

USE PROPER ADAPTERS

Do not attempt to lift trucks or other frame type vehicles with standard flat contact pads. Frame cradle contact pads are recommended for use when lifting trucks, vans, or other frame vehicles. NEVER use lift with missing or damaged rubber pads. ALWAYS REPLACE rubber contact pads when worn or damaged. Contact BendPak or your BendPak dealer for product information.

Optional Equipment available through your Authorized BendPak Dealer.

If the lift was provided with Lift Arm Foot Guards, install the shorter Foot Guard on the shorter Arm Assembly and the longer Foot Guard on the longer Arm Assembly.

To install firmly squeeze the ends of the Foot Guard inwards and insert the ends underneath the bent ends of the arm support. Release to allow the Foot Guard to spring into place. Check to be sure that Foot Guard is firmly in place.

Repeat this step for each Arm Assembly Foot Guard.

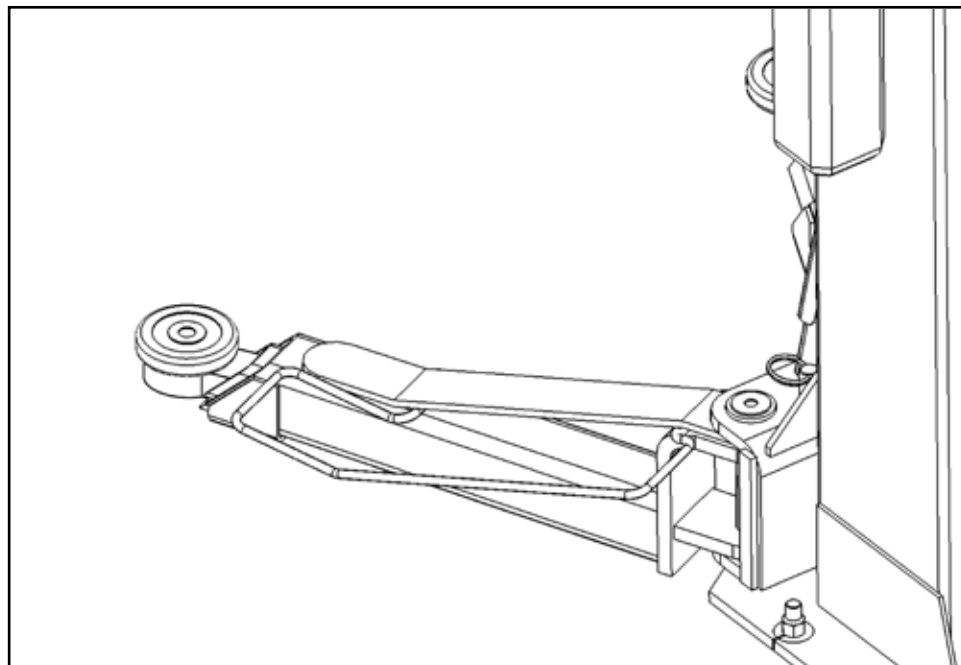
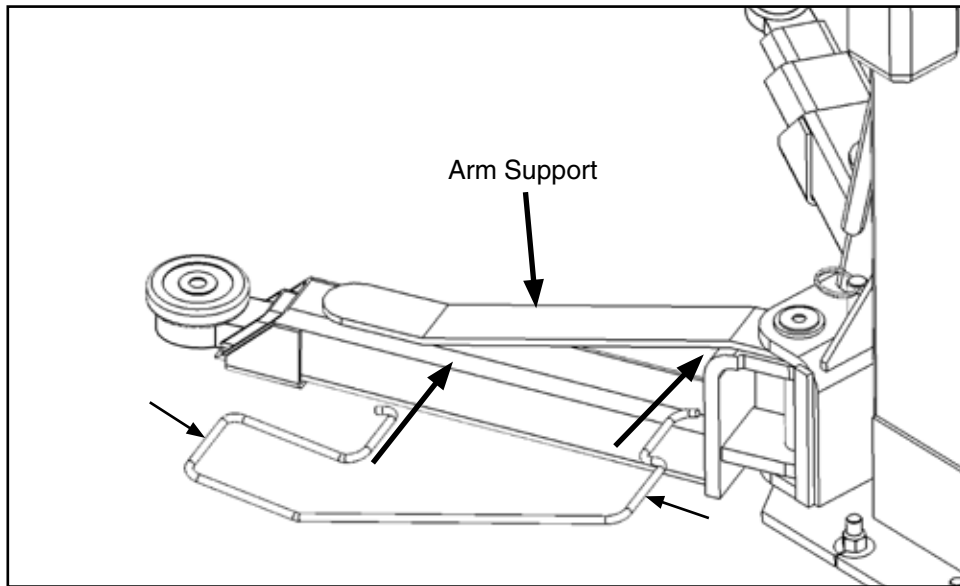

Optional Equipment available through your Authorized BendPak Dealer.

STEP 17 (Operation Instructions)

OWNER/EMPLOYER RESPONSIBILITIES

The Owner/Employer:

- Shall ensure that lift operators are qualified and that they are trained in the safe use and operation of the lift using the manufacturer's operating instructions; ALI/SM01-1, ALI Lifting it Right safety manual; ALI/ST-90 ALI Safety Tips card; ANSI/ALI ALOIM-2000, American National Standard for Automotive Lifts-Safety Requirements for Operation, Inspection and Maintenance; ALI/WL Series, ALI Uniform Warning Label Decals/Placards; and in the case of frame engaging lifts, ALI/LP-GUIDE, Vehicle Lifting Points/Quick Reference Guide for Frame Engaging Lifts.

- Shall establish procedures to periodically inspect the lift in accordance with the lift manufacturer's instructions or ANSI/ALI ALOIM-2000, American National Standard for Automotive Lifts-Safety Requirements for Operation, Inspection and Maintenance; and The Employer shall ensure that lift inspectors are qualified and that they are adequately trained in the inspection of the lift.

- Shall establish procedures to periodically maintain the lift in accordance with the lift manufacturer's instructions or ANSI/ALI ALOIM-2000, American National Standard for Automotive Lifts-Safety Requirements for Operation, Inspection and Maintenance; and The Employer shall ensure that lift maintenance personnel are qualified and that they are adequately trained in the maintenance of the lift.

- Shall maintain the periodic inspection and maintenance records recommended by the manufacturer or ANSI/ALI ALOIM-2000, American National Standard for Automotive Lifts-Safety Requirements for Operation, Inspection and Maintenance.

- Shall display the lift manufacturer's operating instructions; ALI/SM 93-1, ALI Lifting It Right safety manual; ALI/ST-90 ALI Safety Tips card; ANSI/ALI ALOIM-2000, American National Standard for Automotive Lifts-Safety Requirements for Operation, Inspection and Maintenance; and in the case of frame engaging lifts, ALI/LP-GUIDE, Vehicle Lifting Points/Quick Reference Guide for Frame Engaging Lifts; in a conspicuous location in the lift area convenient to the operator.

- Shall provide necessary lockout/tagout means for energy sources per ANSI Z244.1-1982 (R1993), Safety Requirements for the Lockout/Tagout of Energy Sources, before beginning any lift repairs.

- Shall not modify the lift in any manner without the prior written consent of the manufacturer.



LIFT OPERATION SAFETY

- **DAILY** inspect your lift. Never operate if it malfunctions or if it has broken or damaged parts. Use only qualified lift service personnel and genuine BendPak parts to make repairs.

- **THOROUGHLY** train all employees in use and care of lift, using manufacturer's instructions and "Lifting It Right" and "Safety Tips" supplied with the lift.

- **NEVER** allow unauthorized or untrained persons to position vehicle or operate lift.

- **PROHIBIT** unauthorized persons from being in shop area while lift is in use.

- **DO NOT** permit anyone on lift or inside vehicle when it is either being raised or lowered.

- **ALWAYS** keep area around lift free of tools, debris, grease and oil.

- **NEVER** overload lift. Capacity of lift is shown on nameplate affixed to the lift.

- **DO NOT** stand in front of the vehicle while it is being positioned in lift bay.

- **DO NOT** hit or run over lift arms or adapters. This could damage lift or vehicle. Before driving vehicle into lift bay, position arms and adapters to provide unobstructed entrance onto lift.

LIFT OPERATION SAFETY (CONT'D)

- **ALWAYS** load vehicle on lift carefully. Position the lift adapters to contact at the vehicle manufacturer's recommended lift points. Raise lift until adapters contact vehicle. Check adapters for secure contact with vehicle. Raise lift to desired working height. (See Fig.17.1)

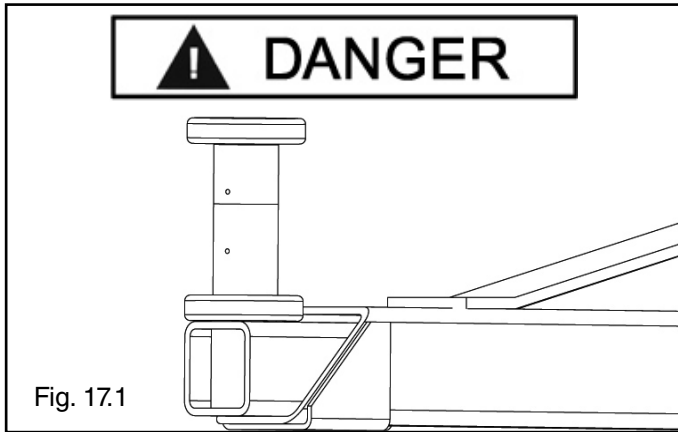

Fig. 17.1

- **DO NOT** block open or override self-closing lift controls; they are designed to return to the "Off" or Neutral position when released.
- **DO NOT** remove or disable arm restraints.
- **ALWAYS** remain clear of lift when raising or lowering vehicles.
- **ALWAYS** use safety stands when removing or installing heavy components.
- **DO NOT** go under raised vehicle if safety locks are not engaged.



VISUALLY CONFIRM THAT ALL PRIMARY SAFETY LOCKS ARE ENGAGED BEFORE ENTERING WORK AREA. SUSPENSION COMPONENTS USED ON THIS LIFT ARE INTENDED TO RAISE AND LOWER LIFT ONLY AND ARE NOT MEANT TO BE LOAD HOLDING DEVICES. REMAIN CLEAR OF ELEVATED LIFT UNLESS VISUAL CONFIRMATION IS MADE THAT ALL PRIMARY SAFETY LOCKS ARE FULLY ENGAGED AND THE LIFT IS LOWERED ONTO THE SAFETY LOCKS, REFER TO INSTALLATION/ OPERATION MANUAL FOR PROPER SAFETY LOCK PROCEDURES AND/OR FURTHER INSTRUCTION.

- **NEVER LEAVE LIFT IN ELEVATED CONDITION** unless all Safety Locks are engaged.
- **AVOID** excessive rocking of vehicle while on lift.
- **ALWAYS CLEAR AREA** if vehicle is in danger of falling.



WHEN LOWERING THE LIFT PAY CAREFUL ATTENTION THAT ALL PERSONNEL AND OBJECTS ARE KEPT CLEAR. ALWAYS KEEP A VISUAL LINE OF SITE ON THE LIFT AT ALL TIMES. ALWAYS MAKE SURE THAT ALL LOCKS ARE DISENGAGED. IF ONE OF THE LOCKS INADVERTENTLY LOCKS ON DESCENT THE LIFT AND/OR VEHICLE MAY DISRUPT CAUSING PERSONAL INJURY OR DEATH.

- **ALWAYS REMOVE** tool trays, stands, etc. before lowering lift.
- **ALWAYS RELEASE** safety locks before attempting to lower lift.
- **ALWAYS POSITION** the lift arms and adapters to provide an unobstructed exit before removing vehicle from lift area.

TO RAISE THE LIFT



TO AVOID PERSONAL INJURY AND/OR PROPERTY DAMAGE, PERMIT ONLY TRAINED PERSONNEL TO OPERATE LIFT. AFTER REVIEWING THESE INSTRUCTIONS, PRACTICE USING LIFT CONTROLS BY RUNNING THE LIFT THROUGH A FEW UNLOADED CYCLES BEFORE LOADING VEHICLE ON LIFT. ALWAYS LIFT THE VEHICLE USING ALL FOUR ADAPTERS. NEVER RAISE JUST ONE END, ONE CORNER, OR ONE SIDE OF VEHICLE.

1. Before Loading: Lift must be fully lowered and service bay clear of all personnel before the vehicle is brought on lift with the swing arms set to the full drive-thru position.
2. Loading: Swing arms under vehicle and position adapters at vehicle manufacturer's recommended lift points. Use height extenders or optional frame-cradle adapters when necessary to ensure good contact. (See Fig 17.2-17.3)
3. Some vehicles may have the manufacturer's Service Garage Lift Point locations identified by triangle shape marks on the undercarriage (reference ANSI/SAE J2184-1992). Also, there may be a label located on the right front door jamb area showing specific vehicle lift points.

LIFT OPERATION SAFETY (CONT'D)

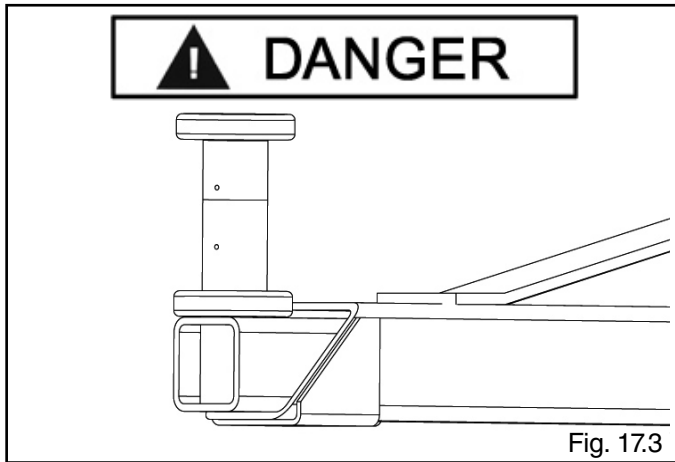
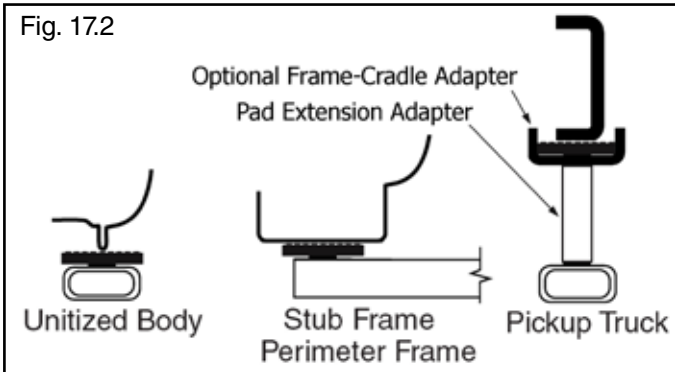

MANY SPECIALTY OR MODIFIED VEHICLES CANNOT BE RAISED ON A TWO-POST FRAME ENGAGING LIFT. CONTACT VEHICLE MANUFACTURER FOR RAISING OR JACKING DETAILS.

- Position vehicle for proper weight distribution arms under vehicle to allow adapters to contact at the manufacturer's recommended pick up points.

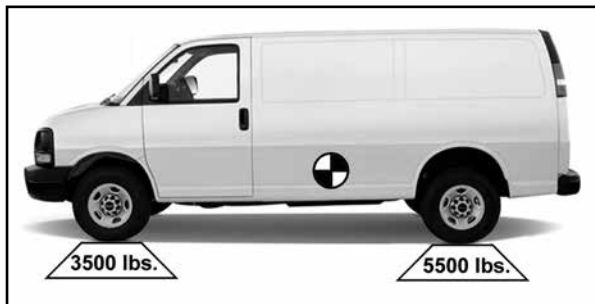

- If the specific vehicle lift points are not identified, refer to the VEHICLE CENTER OF BALANCE instructions found on our website at

<http://www.bendpak.com/support/balancing-safety/>

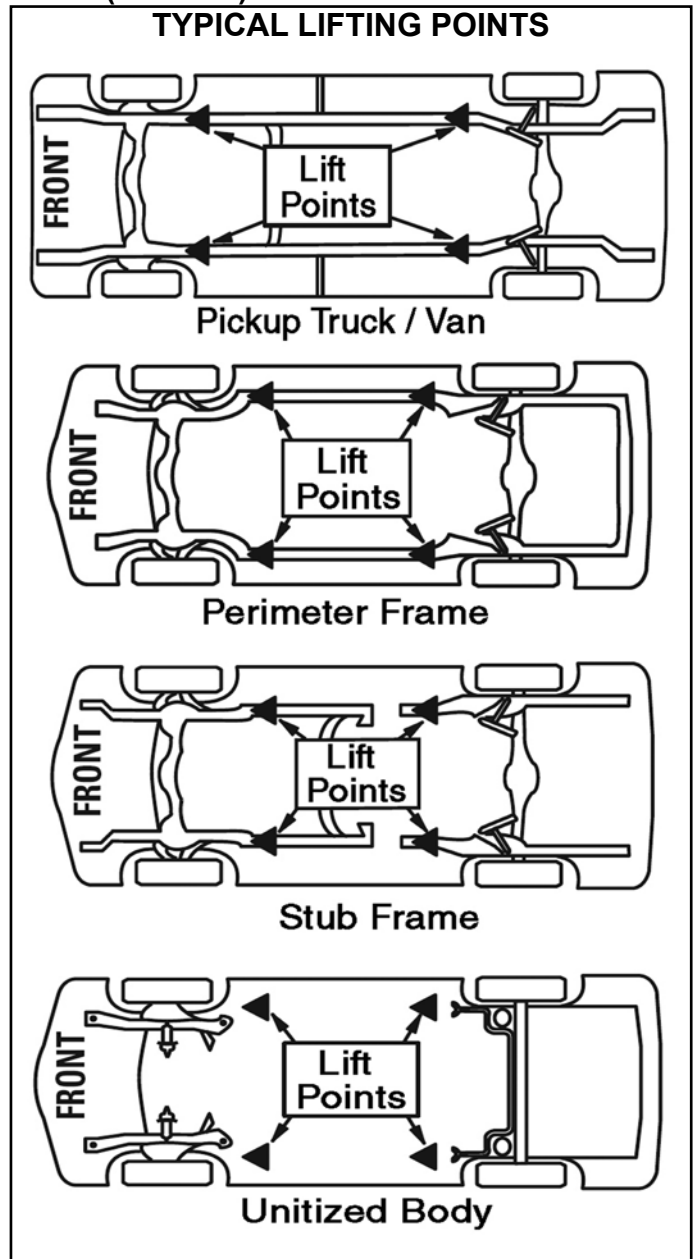

- Push the **RAISE** button or rotate the control switch on the power unit.

NOTE:
ALLOW (2) SECONDS BETWEEN MOTOR STARTS.
FAILURE TO COMPLY MAY CAUSE MOTOR BURNOUT.

- Stop before making contact with vehicle. Check arm restraint pins for engagement. If required, slightly move arm to allow restraint gear and pawl to mesh. **DO NOT** hammer arm restraint pin down as this will damage the restraint gear teeth.
- Raise vehicle until tires clear the floor.
- Stop and check adapters for secure contact at vehicle manufacturer's recommended lift points.

LIFT OPERATION SAFETY (CONT'D)

TO LOWER THE LIFT

10. Continue to raise to desired height only if vehicle is secure on lift.

11. **DO NOT** go near or under a raised vehicle if all four adapters are not in secure contact with vehicle at vehicle manufacturer's recommended lift points.

12. Repeat entire loading and raising procedures if required.

13. Lower lift onto safety locks.



VISUALLY CONFIRM THAT ALL PRIMARY SAFETY LOCKS ARE ENGAGED BEFORE ENTERING WORK AREA. SUSPENSION COMPONENTS USED ON THIS LIFT ARE INTENDED TO RAISE AND LOWER LIFT ONLY AND ARE NOT MEANT TO BE LOAD HOLDING DEVICES. REMAIN CLEAR OF ELEVATED LIFT UNLESS VISUAL CONFIRMATION IS MADE THAT ALL PRIMARY SAFETY LOCKS ARE FULLY ENGAGED AND THE LIFT IS LOWERED ONTO THE SAFETY LOCKS, REFER TO INSTALLATION /OPERATION MANUAL FOR PROPER SAFETY

- **DO NOT** enter work area or go under vehicle if safety locks are not engaged.
- **CLEAR AREA** if vehicle is in danger of falling.
- **DO NOT** position yourself between a wall and the lift. If the vehicle falls in that direction, you may be severely injured or killed.
- Before attempting to lift pickup trucks or other truck frame vehicles, be sure that:
 - ◆ Vehicle frame is strong enough to support its weight and has not been weakened by modification or corrosion.
 - ◆ Vehicle individual axle weight does not exceed one-half lift capacity.
 - ◆ Adapters are in secure contact with frame at vehicle manufacturer's recommended lift points.
 - ◆ Vehicle is stable on lift and the center of gravity is NOT off balance.
 - ◆ The overhead switch bar will contact the highest point on the vehicle.

WHILE USING LIFT

- Avoid excessive rocking of vehicle while on lift.
- Always use safety stands as needed or when removing or installing heavy components.



WHEN LOWERING THE LIFT PAY CAREFUL ATTENTION THAT ALL PERSONNEL AND OBJECTS ARE KEPT CLEAR. ALWAYS KEEP A VISUAL LINE OF SITE ON THE LIFT AT ALL TIMES. ALWAYS MAKE SURE THAT ALL LOCKS ARE DISENGAGED. IF ONE OF THE LOCKS INADVERTENTLY LOCKS ON DESCENT THE LIFT AND/OR VEHICLE MAY DISRUPT CAUSING PERSONAL INJURY OR DEATH.

1. Remove all tools or other objects from the lift area.
2. Raise lift off safety locks. Ensure lift is raised by at least two inches to allow adequate clearance for the locks to clear.
3. Push safety lock release handle fully and hold.
4. Push LOWERING valve handle to lower. Note: Both SAFETY LOCK release and LOWERING valve handles must be held down simultaneously to lower lift. Do not override self-closing lift controls.
5. Remain clear of lift when lowering vehicle. Observe pinch point warning decal instructions.
6. Remove adapters from under vehicle and swing arms to full drive-thru position before moving vehicle.
7. If lift is not operating properly, DO NOT use until adjustment or repairs are made.

MAINTENANCE INSTRUCTIONS



IF YOU ARE NOT COMPLETELY FAMILIAR WITH AUTOMOTIVE LIFT MAINTENANCE PROCEDURES; STOP AND CONTACT THE MANUFACTURER FOR INSTRUCTIONS. TO AVOID PERSONAL INJURY, PERMIT ONLY QUALIFIED PERSONNEL TO PERFORM MAINTENANCE ON THIS EQUIPMENT.

- Always keep bolts tight. Check periodically.
- Always keep lift components clean.
- Always if oil leakage is observed, call local service representative.

- Always replace ALL FAULTY PARTS before lift is put back into operation.
- Daily: Make a visual inspection of ALL MOVING PARTS and check for excessive signs of wear.
- Daily: Check safety locks to ensure they are in good operating condition.
- Daily: Check cables and sheaves for wear. Replace worn parts as required with genuine BendPak parts.
- Daily: Inspect adapters for damage or excessive wear. Replace as required with genuine BendPak parts.
- Weekly: Lubricate all sheaves and rollers with general purpose oil.
- Weekly: Check all cable connections, bolts and pins to ensure proper mounting.
- Monthly: Check equalizer cable tension. Adjust per lift installation instructions.
- Monthly: Lubricate locking latch shafts. Push latch handle several times for oil to penetrate pivot points.
- Every 3 Months: Check anchor bolt torque. Anchors should be torqued to 90 ft/lbs.
- Semi-Annually: Check fluid level of lift power unit and refill if required per lift installation instructions.
- Replace all caution, warning or safety related decals on the lift if unable to read or missing. Reorder labels from BendPak.
- Refer to ANSI/ALI ALOIM booklet for periodic inspection checklist and maintenance log sheet.

! WARNING

Center of balance should be midway between adapters.

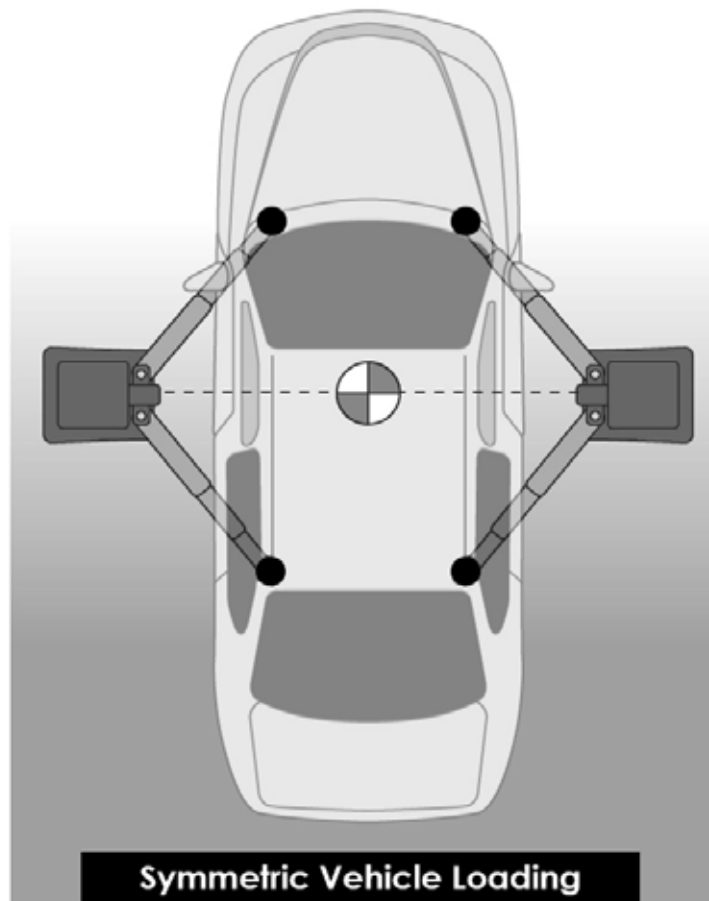

TO RAISE LIFT

- ◆ Read operating and safety manuals before using lift.
- ◆ Always lift a vehicle according to the manufacturers recommended lifting points.
- ◆ Position vehicle between posts.
- ◆ Adjust swing arms so that the vehicle is positioned with the center of gravity midway between pads.
- ◆ Use truck adapters as needed. Never exceed 9" of pad height.
- ◆ **NEVER** use lift pad assemblies without rubber slip over pads in place.
- ◆ Raise the vehicle by depressing button until the vehicle just lifts off the ground. Re-check to make sure the vehicle is secure and all locking pins are lock in place.
- ◆ Raise vehicle to desired height. Lower vehicle onto nearest safety,
- ◆ Always ensure safeties are engaged before any attempt is made to work on or near vehicle.

TO LOWER THE LIFT

- ◆ First raise the lift clear to the safeties.
- ◆ Release safeties by pulling on the safety handle.
- ◆ Be sure tool trays, stands or personnel are cleared from under the vehicle.
- ◆ Lower vehicle by activating lowering handle on power unit.
- ◆ Before removing vehicle from lift; position lift arms and supports to provide an unobstructed exit.
- ◆ **NEVER**, drive over lift arms.

REQUIRED MONTHLY MAINTENANCE

- ◆ Check all arm adjusting locks for proper operation.
- ◆ Check all cables connections, bolts and pins to insure proper mounting and torque.
- ◆ Visually inspect safeties for proper operation.
- ◆ Lubricate posts with grease.
- ◆ Inspect all anchors bolts and retighten if necessary.
- ◆ Check all posts for squareness and plumb.
- ◆ Inspect all pivot arms pins making sure they are properly secure.
- ◆ Check equalizer cable tension, and adjust if necessary.
- ◆ If lift is equipped with over head microswitch, check for proper operation.



1. If cement anchor bolts are loose or any component of the lift is found to be defective, **DO NOT USE THE LIFT!**
2. Never operate the lift with any person or equipment below the vehicle.
3. Never exceed the rated lift capacity.
4. Always ensure the safeties are engaged before any attempt is made to work on or near the vehicle.
5. Never leave lift in elevated position unless the safeties are engaged.
6. Do not permit electric motor to get wet! Motor damage caused by dampness is not covered under warranty.



NEVER LIFT ANY VEHICLE IN ANY MANNER WITH LESS THAN ALL FOUR (4) ARMS. RATED CAPACITY OF EACH LIFT ARM IS NO GREATER THAN ONE FOURTH (1/4) OF THE OVERALL LIFT CAPACITY.



WIRE ROPE INSPECTION AND MAINTENANCE

◆ Lifting cables should be replaced every three - five years or when visible signs of damage are apparent. **DO NOT USE LIFT WITH DEFECTIVE / WORN CABLES.**

◆ Lifting cables should be maintained in a well-lubricated condition at all times. Wire rope is only fully protected when each wire strand is lubricated both internal and external. Excessive wear will shorten the life of the wire rope. The factory suggested wire rope lubricant that penetrates to the core of the rope and provides long-term lubrication between each individual strand is 90-WT gear oil or ALMASOL® Wire Rope Lubricant. In order to make sure that the inner layers of the rope remain well lubricated, lubrication should be carried out at intervals not exceeding three months during operation.

◆ All sheaves and guide rollers in contact with the moving rope should be given regular visual checks for surface wear and lubricated to make sure that they run freely. This operation should be carried out at appropriate intervals generally not exceeding three months during operation. For all sheave axles, the factory recommends standard wheel bearing grease. For all sheaves and/or guide rollers, the factory recommends 90-WT gear oil or similar heavy lubricant applied by any method including pump / spray dispensing, brush, hand and/or swabbing.

HOW OFTEN TO INSPECT

◆ Lifting cables should be visually inspected at least once each day when in use, as suggested by American Petroleum Institute (API) RP54 guidelines.

◆ Any lifting cables that have met the criteria for removal must be immediately replaced.

WHEN TO REPLACE LIFTING CABLES DUE TO BROKEN WIRES

◆ Lifting cables should be removed from service when you see six randomly distributed broken wires within any one lay length, or three broken wires in one strand within one lay length.

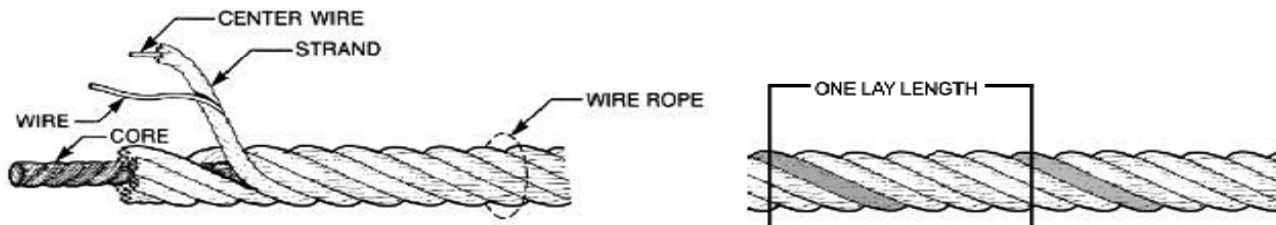

The three basic components of a typical wire rope.

OTHER REASONS TO REPLACE LIFTING CABLES

- ◆ Corrosion that pits the wires and/or connectors.
- ◆ Evidence of kinking, crushing, cutting, bird-caging or a popped core.
- ◆ Wear that exceeds 10% of a wire's original diameter.
- ◆ Evidence of heat damage.

HOW TO FIND BROKEN WIRES

◆ The first step is to relax your rope to a stationary position and move the pick-up points off the sheaves. Clean the surface of the rope with a cloth — a wire brush, if necessary — so you can see any breaks.

◆ Flex the rope to expose any broken wires hidden in the valleys between the strands.

◆ Visually check for any broken wires. One way to check for crown breaks is to run a cloth along the rope to check for possible snags.

◆ With an awl, probe between wires and strands and lift any wires that appear loose. Evidence of internal broken wires may require a more extensive rope examination.

BENDPAK

A

B

C

EP BendPak. 1645 Lemoore Rd. Santa Paula, CA USA www.BendPak.com

LIFT TYPE: Surface Mount **MANUFACTURER:** BendPak. See data plate for product details

POWER: Electric/Hydraulic **INSTALLATION:** See manual or contact factory

Safety Instructions: If attachments, accessories, or configuration-modifying components that are located in the load path affect operation of the lift, affect the lift electrical wiring, or affect intended vehicle accommodation, are used on this lift and, if they are not certified for use on this lift, then the certification of this lift shall become null and void. Contact the participant for information pertaining to certified attachments, accessories, or configuration-modifying components.

BendPak lifts are supplied with concrete fasteners meeting the criteria as prescribed by ASTM (409/4458) 16 L10 bytes are responsible for any special regional, structural, anchor seismic anchoring requirements specified by any other agencies and/or codes such as the Uniform Building Code (UBC) and/or International Building Code (IBC).

The manufacturer, use, sale, or import of this product may be subject to one or more United States patents, or pending applications, owned by **BendPak Inc.**

Do Not Retain **Engineered by BendPak Inc., USA** **76 (2014)**
Made in China

IMPORTANT	IMPORTANT
OPERATION / MAINTENANCE INSTRUCTIONS - PLEASE READ	OPÉRATION / ENTRETIEN INSTRUCTIONS - LISEZ V'Œ VOS PLATS
⚠ DANGER ⚠	
<p>Long-obsolete vehicles (over 10 years old) are not covered by this manual. If you are unsure of the vehicle's condition, consult the manufacturer's manual. All vehicles MUST be positioned on a flat, level surface. CENTER OF GRAVITY midway between adapters.</p>	<p>Les véhicules à longévité prolongée (plus de 10 ans) ne sont pas couverts par ce manuel. Si vous n'êtes pas sûr de l'état de votre véhicule, consultez le manuel du fabricant. Tous les véhicules DOIVENT être placés sur une surface plane et horizontale. Le CENTRE DE GRAVITÉ se situe entre les adaptateurs.</p>
⚠ CAUTION ⚠ ⚠ MISE EN GARDE ⚠	
<p>Never lift any vehicle or any component more than its rated capacity or more than 100% of the rated lifting capacity.</p>	<p>Ne jamais soulever un véhicule ou un composant au-delà de sa capacité nominale ou plus de 100% de la capacité nominale de levage.</p>
⚠ WARNING ⚠ ⚠ ATTENTION ⚠	
<p>USE PROPER ADAPTERS Do not attempt to lift any vehicle or component with adapters not specified in this manual. Use the correct adapter for the vehicle and component. Contact BendPak or your distributor for product information.</p>	<p>UTILISEZ DES ADAPTEURS APPROPRIÉS N'essayez pas de soulever un véhicule ou un composant avec des adaptateurs non spécifiés dans ce manuel. Utilisez l'adaptateur approprié pour le véhicule et le composant. Contactez BendPak ou votre distributeur pour obtenir des informations sur les adaptateurs.</p>
<p>STEEL LIFT PADS Use 1/2" thick steel lift pads for all vehicles. Do not use wooden lift pads. Do not use lift pads that are not specifically designed for this lift.</p>	<p>ADAPTEURS DE CAISSE Utilisez des adaptateurs de caisse en acier pour tous les véhicules. Ne pas utiliser d'adaptateurs en bois. Ne pas utiliser d'adaptateurs qui ne sont pas spécialement conçus pour cet élévateur.</p>
<p>WIRE FRAME OR RAIL ADAPTERS Use 1/2" thick wire frame or rail adapters for all vehicles. Do not use wooden adapters. Do not use adapters that are not specifically designed for this lift.</p>	<p>RAILS LANGE ADAPTEURS Utilisez des rails langes adaptateurs en acier pour tous les véhicules. Ne pas utiliser d'adaptateurs en bois. Ne pas utiliser d'adaptateurs qui ne sont pas spécialement conçus pour cet élévateur.</p>
<p>PIPE & TUB ADAPTERS Use 1/2" thick pipe and tub adapters for all vehicles. Do not use wooden adapters. Do not use adapters that are not specifically designed for this lift.</p>	<p>POUR & ADAPTEURS SANS Utilisez des adaptateurs en tuyau et en tube pour tous les véhicules. Ne pas utiliser d'adaptateurs en bois. Ne pas utiliser d'adaptateurs qui ne sont pas spécialement conçus pour cet élévateur.</p>
<p>REPLACEMENT POLYURETHANE TOP PADS Use 1/2" thick polyurethane top pads for all vehicles. Do not use wooden top pads. Do not use top pads that are not specifically designed for this lift.</p>	<p>REEMPLACEMENT POLYURETHANE TOP PADS Utilisez des pads en polyuréthane pour tous les véhicules. Ne pas utiliser de pads en bois. Ne pas utiliser de pads qui ne sont pas spécialement conçus pour cet élévateur.</p>
<p>TO PLACE ORDER Monday - Friday 9 AM - 5 PM PST 1-800-822-8876</p>	<p>POUR COMMANDER Lundi - Vendredi 9h - 17h 1-800-822-8876</p>
⚠ WARNING ⚠ ⚠ ATTENTION ⚠	
<p>NEVER LIFT EXCEEDING THE RATED CAPACITY Do not exceed the rated lifting capacity of the lift. Do not lift more than the rated capacity of the lift. Do not lift more than the rated capacity of the lift. Do not lift more than the rated capacity of the lift.</p>	<p>NEVER LIFT EXCEEDING THE RATED CAPACITY Ne jamais soulever au-delà de la capacité nominale de levage de l'élévateur. Ne pas soulever plus que la capacité nominale de levage de l'élévateur. Ne pas soulever plus que la capacité nominale de levage de l'élévateur. Ne pas soulever plus que la capacité nominale de levage de l'élévateur.</p>
<p>LIFT OPERATION 1. Position the vehicle on the lift pads. 2. Lower the lift arms to the vehicle. 3. Raise the lift arms to lift the vehicle. 4. Lower the lift arms to the ground. 5. Remove the lift pads from the vehicle.</p>	<p>OPERATION DE LEVAGE 1. Positionner le véhicule sur les pads. 2. Baisser les bras de levage sur le véhicule. 3. Lever les bras de levage pour soulever le véhicule. 4. Baisser les bras de levage sur le sol. 5. Retirer les pads de levage du véhicule.</p>

D

E

⚠ DANGER ⚠

THE MAXIMUM LIFTING CAPACITY FOR THIS LIFT IS DESCRIBED BELOW

Maximum Lifting Capacity 12,000 lbs. / 5,443 kg
Max. Lifting Cap. / Front of Lift Center 6,000 lbs. / 2,722 kg
Max. Lifting Cap. / Rear of Lift Center 6,000 lbs. / 2,722 kg

Exceeding the weight capacity of this lift can damage lift and/or property and may cause personal harm, injury or death to operators and/or bystanders. All vehicles MUST be positioned on lift with CENTER OF GRAVITY midway between adapters and/or centered on runways. Damage to lift due to overloading or misuse IS NOT covered under warranty.

⚠ ATTENTION ⚠

MAXIMUM LIFTING CAPACITY CAPACITÉ DE LEVAGE MAXIMUM

12000 Lbs.

5443 Kg.

G

LA CAPACITÉ DE LEVAGE MAXIMUM POUR CE LEVAGE EST DÉCRIT CI-DESSOUS

Capacité de Levage Maximale 12,000 lbs. / 5,443 kg
Max. Capacité de Levage / Avant de centre de renforcement 6,000 lbs. / 2,722 kg
Max. Capacité de Levage / Arrière de centre de levage 6,000 lbs. / 2,722 kg

Le dépassement de la capacité de poids de cet élévateur peut endommager l'élévateur et / ou les biens et peut causer des dommages corporels, des blessures voire la mort aux opérateurs et / ou aux passants. Tous les véhicules DOIVENT être placés sur l'élévateur avec le CENTRE DE GRAVITÉ à mi-chemin entre les adaptateurs et / ou au centre des pistes. Dommages à soulever dus à la surcharge ou une mauvaise utilisation N'EST PAS couverts par la garantie.

PLEASE READ

Internal packing oil may cause the cylinders to bleed oil during start up. This is normal. To extend cylinder and seal life, raise the lift to full height at least once every day.

H

I

CERTIFIED AUTOMOTIVE LIFT

CERTIFIED

ALL CERTIFIED
to the provisions of
ANSI/ALI ALC-TV-2017
SAFETY REQUIREMENTS FOR
CONSTRUCTION TRUCKS
AND JACKSCREWS

MET LISTED
Compliance to
ANSI/ALI 2017
SAFETY REQUIREMENTS FOR
CONSTRUCTION TRUCKS
AND JACKSCREWS

MET LISTED
Compliance to
ANSI/ALI 2017
SAFETY REQUIREMENTS FOR
CONSTRUCTION TRUCKS
AND JACKSCREWS













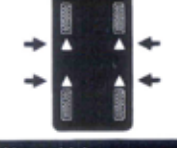

ALXASAMPLX2X

NOTICE

if attachments, accessories, or configuration-modifying components used on this lift are located in the load path and affect operation of the lift, affect the lift electrical wiring, or affect intended vehicle accommodation; and if they are not certified for use on this lift, then the certification of this lift shall become null and void. Contact the participant for information pertaining to certified attachments, accessories, or configuration-modifying components.

www.autoift.org ©2011 by ALL, Inc. ALI/WSIA01

F

<p>NOTICE</p>  <p>Read operating and safety manuals before using lift.</p>	<p>CAUTION</p>  <p>Lift to be used by trained operator only.</p>	<p>CAUTION</p>  <p>Authorized personnel only in lift area.</p>	<p>WARNING</p>  <p>Clear area if vehicle is in danger of falling.</p>	<p>WARNING</p>  <p>Position vehicle with center of gravity midway between adapters.</p>
<p>NOTICE</p>  <p>Proper maintenance and inspection is necessary for safe operation.</p>	<p>CAUTION</p>  <p>Use vehicle manufacturer's lift points.</p>	<p>CAUTION</p>  <p>Always use safety stands when removing or installing heavy components.</p>	<p>WARNING</p>  <p>Remain clear of lift when raising or lowering vehicle.</p>	<p>WARNING</p>  <p>Avoid excessive rocking of vehicle while on lift.</p>
<p>NOTICE</p>  <p>Do not operate a damaged lift.</p>	<p>CAUTION</p>  <p>Use height extenders when necessary to ensure good contact.</p>	<p>CAUTION</p>  <p>Auxiliary adapters may reduce load capacity.</p>	<p>WARNING</p>  <p>Do not override self-closing lift controls.</p>	<p>WARNING</p>  <p>Keep feet clear of lift while lowering.</p>

L

<p>TO RAISE LIFT:</p> <ol style="list-style-type: none"> 1. Press and hold UP button. 2. When lift is just PAST desired height, release UP button. 3. Hold down Lowering Handle. DO NOT hold down Safety Lock Release Handle. Lift engages on safety locks. 4. Release Lowering Handle. 	<p>TO LOWER LIFT:</p> <ol style="list-style-type: none"> 1. Press and hold UP button for two to three seconds, moving lift off safety locks. 2. Hold down Safety Lock Release Handle and Lowering Handle. 3. When lift is fully lowered, release both handles.
----------------------------------------------------------------------------------------------------------------------------------------------------------------------------------------------------------------------------------------------------------------------------------------------------------------------------------------------------------------------	----------------------------------------------------------------------------------------------------------------------------------------------------------------------------------------------------------------------------------------------------------------------------------------------------------------------

PN 5905414

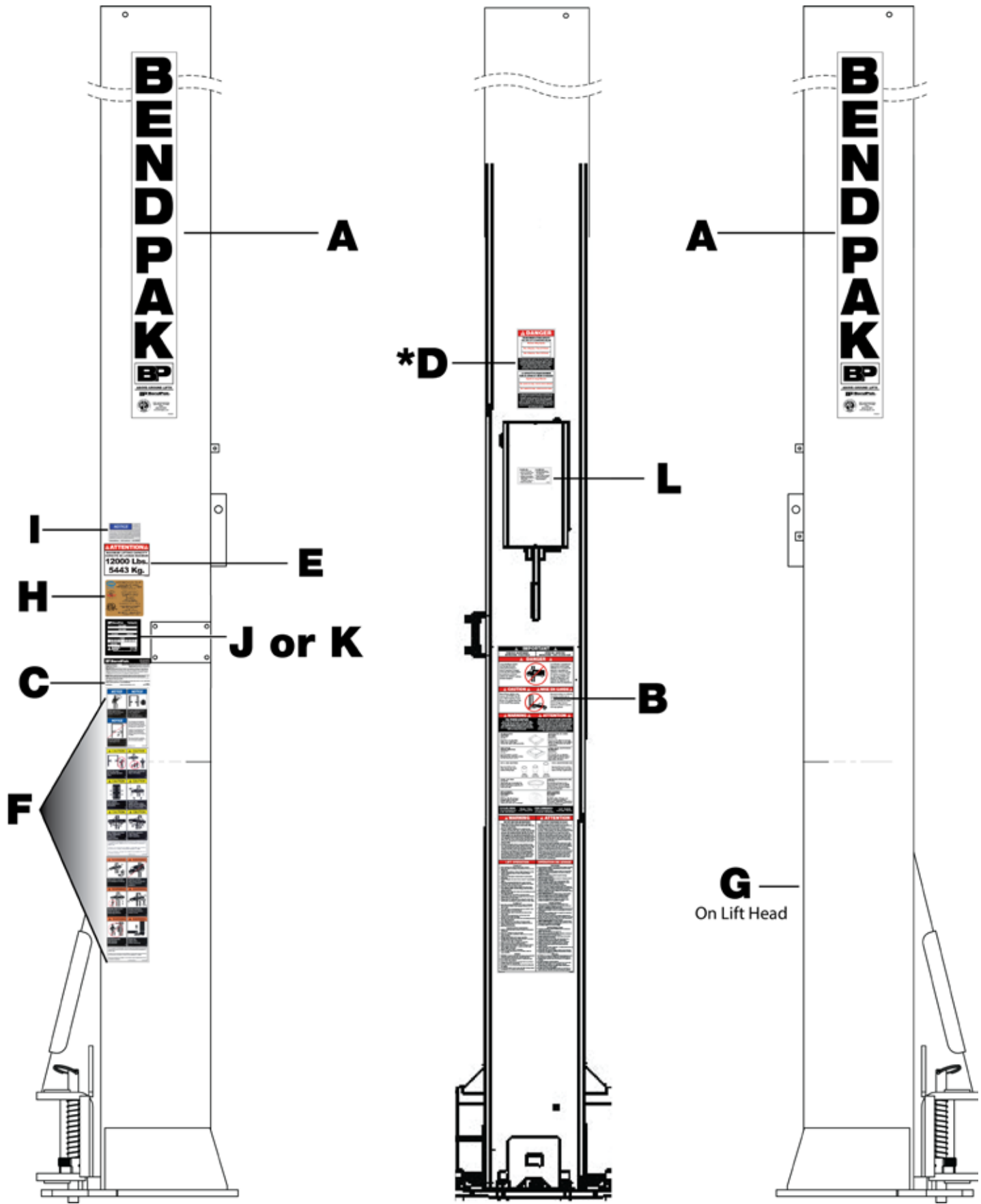

Safe Lift Operation

Automotive and truck lifts are critical to the operation and profitability of your business. The safe use of this and other lifts in your shop is critical in preventing employee injuries and damage to customer's vehicles. By operating lifts safely you can insure that your shop is profitable, productive and safe.

Safe operation of automotive lifts requires that only trained employees should be allowed to use the lift.

TRAINING SHOULD INCLUDE, BUT NOT LIMITED TO:

- ◆ Proper positioning of the vehicle on the lift arms. (See manufacturers minimize wheel base loading requirements.)
- ◆ Use of the operating controls.
- ◆ Understanding the lift capacity.
- ◆ Proper use of jack stands or other load supporting devices.
- ◆ Proper use, understanding and visual identification of safety lock devices and their operation.
- ◆ Reviewing the safety rules.
- ◆ Proper housekeeping procedures (lift area should be free of grease, oil, tools, equipment, trash, and other debris).
- ◆ A daily inspection of the lift should be completed prior to its use. Safety devices, operating controls, lift arms and other critical parts should be inspected prior to using the lift.
- ◆ All maintenance and repairs of the lift should be completed by following the manufacturer's requirements. Lift repair parts should meet or exceed OEM specifications. Repairs should only be completed by a qualified lift technician.
- ◆ The vehicle manufacturer's recommendations should be used for spotting and lifting the vehicle.

LIFT OPERATION / SAFETY

- ◆ It is important that you know the load limit. Be careful that you do not overload the lift . If you are unsure what the load limit is, check the data plate found on one of the lift columns or contact the manufacturer.
- ◆ The center of gravity should be followed closely to what the manufacturer recommends.
- ◆ Always make sure you have proper overhead clearance. Additionally, check that attachments, (vehicle signs, campers, antennas, etc.) are not in the way.
- ◆ Be sure that prior to the vehicle being raised, the doors, trunk, and hood are closed securely.
- ◆ Prior to being raised, make sure there is no one standing closer than six feet from the lift.
- ◆ After positioning the vehicle on the lift runways, set the emergency brake, make sure the ignition is off, the doors are closed, overhead obstructions are cleared, and the transmission is in neutral.
- ◆ Double check that the automatic chock devices are in position and then when the lift is raised, observe the chocks.
- ◆ Put pads or adapters in the right position under the contact points that have been recommended.
- ◆ The lift should be raised just until the vehicle's wheels are about one foot off the ground. If contact with the vehicle is uneven or it appears that the vehicle is not sitting secure, carefully lower the lift and readjust.
- ◆ Always consider potential problems that might cause a vehicle to slip, i.e., heavy cargo, undercoating, etc.
- ◆ Pay attention when walking under a vehicle that is up on the hydraulic lift.



- ◆ **DO NOT** leave the controls while the lift is still in motion.
- ◆ **DO NOT** stand directly in front of the vehicle or in the bay when vehicle is being loaded or driven into position.
- ◆ **DO NOT** go near vehicle or attempt to work on the vehicle when being raised or lowered.
- ◆ **REMAIN CLEAR** of lift when raising or lowering vehicle.
- ◆ **DO NOT** rock the vehicle while on the lift or remove any heavy component from vehicle that may cause excessive weight shift.
- ◆ **DO NOT** lower the vehicle until people, materials, and tools are clear
- ◆ **ALWAYS ENSURE** that the safeties are engaged and lowered on to the safeties before any attempt is made to work on or near vehicle.
- ◆ Some vehicle maintenance and repair activities may cause the vehicle to shift. Follow the manufacturer's guidelines when performing these operations. The use of jack stands or alternate lift points may be required when completing some repairs.
- ◆ **READ AND UNDERSTAND** all safety warning procedures before operating lift.
- ◆ **KEEP HANDS AND FEET CLEAR.** Remove hands and feet from any moving parts. Keep feet clear of lift when lowering. Avoid pinch points.
- ◆ **ONLY TRAINED OPERATORS** should operate this lift. All non-trained personnel should be kept away from work area. Never let non-trained personnel come in contact with, or operate lift.
- ◆ **USE LIFT CORRECTLY.** Use lift in the proper manner. Never use lifting adapters other than what is approved by the manufacturer.
- ◆ **DO NOT** override self-closing lift controls.
- ◆ **CLEAR AREA** if vehicle is on danger of falling.
- ◆ **STAY ALERT.** Watch what you are doing. Use common sense. Be aware.
- ◆ **CHECK FOR DAMAGED PARTS.** Check for alignment of moving parts, breakage of parts or any condition that may affect its operation. Do not use lift if any component is broken or damaged.
- ◆ **NEVER** remove safety related components from the lift. Do not use lift if safety related components are damaged or missing.
- ◆ When the lift is being lowered, make sure everyone is standing at least six feet away.
- ◆ Be sure there are no jacks, tools, equipment, left under the lift before lowering.
- ◆ Always lower the vehicle down slowly and smoothly.

LIFT WILL NOT RAISE

POSSIBLE CAUSE

1. Air in oil, (1,2,8,13)
2. Cylinder binding, (9)
3. Cylinder leaks internally, (9)
4. Motor run backward under pressure, (11)
5. Lowering valve leaks, (3,4,6,10,11)
6. Motor runs backwards, (7,14,11)
7. Pump damaged, (10,11)
8. Pump won't prime, (1,8,13,14,3,12,10,11)
9. Relief valve leaks, (10,11)
10. Voltage to motor incorrect, (7,14,11)

REMEDY

INSTRUCTION

- | | |
|----------------------------------------------------------------------|------------------------------------------------------------------------------------------------|
| 1. Check for proper oil level. | The oil level should be up to the bleed screw in the reservoir with the lift all the way down. |
| 2. Bleed cylinders. | See Installation Manual |
| 3. Flush release valve to get rid of. possible contamination | Hold release handle down and start unit allowing it to run for 15 seconds. |
| 4. Dirty oil. | Replace oil with clean Dexron ATF. |
| 5. Tighten all fasteners. | Tighten fasteners to recommended torques. |
| 6. Check for free movement of release. | If handle does not move freely, replace bracket or handle assembly. |
| 7. Check if motor is wired correctly. | Compare wiring of motor to electrical diagram on drawing. |
| 8. Oil seal damaged or cocked | Replace oil seal around pump shaft. |
| 9. See Installation Manual | Contact BendPak Customer Support. |
| 10. Replace with new part | Replace with new part. |
| 11. Return unit for repair | Return unit for repair. |
| 12. Check pump-mounting bolts | Bolts should be 15 to 18 ft. lbs. |
| 13. Inlet screen clogged | Clean inlet screen or replace. |
| 14. Check wall outlet voltages and wiring | Make sure unit and wall outlet are wired properly. |

LIFT WILL NOT RAISE

POSSIBLE CAUSE

1. Air in oil, (1,2,8,13)
2. Cylinder binding, (9)
3. Cylinder leaks internally, (9)
4. Motor run backward under pressure, (11)
5. Lowering valve leaks, (3,4,6,10,11)
6. Motor runs backwards, (7,14,11)
7. Pump damaged, (10,11)
8. Pump won't prime, (1,8,13,14,3,12,10,11)
9. Relief valve leaks, (10,11)
10. Voltage to motor incorrect, (7,14,11)

REMEDY

1. Check for proper oil level.
2. Bleed cylinders.
3. Flush release valve to get rid of possible contamination
4. Dirty oil.
5. Tighten all fasteners.
6. Check for free movement of release.
7. Check if motor is wired correctly.
8. Oil seal damaged or cocked
9. See Installation Manual
10. Replace with new part
11. Return unit for repair
12. Check pump-mounting bolts
13. Inlet screen clogged
14. Check wall outlet voltages and wiring

INSTRUCTION

- The oil level should be up to the bleed screw in the reservoir with the lift all the way down.
- See Installation Manual
- Hold release handle down and start unit allowing it to run for 15 seconds.
- Replace oil with clean Dexron ATF.
- Tighten fasteners to recommended torques.
- If handle does not move freely, replace bracket or handle assembly.
- Compare wiring of motor to electrical diagram on drawing.
- Replace oil seal around pump shaft.
- Contact BendPak Customer Support.
- Replace with new part.
- Return unit for repair.
- Bolts should be 15 to 18 ft. lbs.
- Clean inlet screen or replace.
- Make sure unit and wall outlet are wired properly.

MOTOR WILL NOT RUN

POSSIBLE CAUSE

1. Fuse blown, (5,2,1,3,4)
2. Limit switch burned out, (1,2,3,4)
3. Microswitch burned out, (1,2,3,4)
4. Motor burned out, (1,2,3,4,6)
5. Voltage to motor incorrect, (2,1,8)

REMEDY

1. Check for correct voltage
2. Check motor is wired correctly
3. Don't use extension cords
4. Replace with new part
5. Reset circuit breaker/fuse
6. Return unit for repair
7. See Installation Manual
8. Check wall outlet voltage and wiring

INSTRUCTION

1. Compare supply voltage with voltage on motor name tag. Check that the wire is sized correctly. N.E.C. table 310-12 requires AWG 10 for 25 Amps.
2. Compare wiring of motor to electrical diagram on drawing.
3. According to N.E.C. : " The size of the conductors... should be such that the voltage drop would not exceed 3% to the farthest outlet for power..." Do not run motor at 115 VAC – damage to the motor will occur.
4. Replace with new part.
5. Reset circuit breaker/fuse.
6. Return unit for repair.
7. See Installation Manual.
8. Make sure unit and wall outlet is wired properly. Motor must run at 208/230 VAC.

LIFT LOWERS SLOWLY OR NOT AT ALL

POSSIBLE CAUSE

1. Cylinders binding, (1)
2. Release valve clogged, (5,4,2,3)
3. Pressure fitting too long, (6)

REMEDY

1. See Installation Manual
2. Replace with new part
3. Return for repair
4. Check oil.
5. Clean release valve
6. Replace fitting with short thread lead

INSTRUCTION

1. Contact BendPak Customer Support.
2. Replace with new part.
3. Return for repair.
4. Use clean 10-WT hydraulic oil or Dexron-III automatic transmission fluid only. If ATF is contaminated, replace with clean ATF and clean entire system.
5. Wash release valve in solvent and blow out with air.
6. Replace fitting with short thread lead.

WILL NOT RAISE LOADED LIFT

POSSIBLE CAUSE

1. Air in oil, (1,2,3,4)
2. Cylinder binding, (5)
3. Cylinder leaks internally, (5)
4. Lift overloaded, (6,5)
5. Lowering valve leaks, (7,8,1,5,9)
6. Motor runs backwards, (10,12,9)
7. Pump damaged, (5,9)
8. Pump won't prime, (1,2,3,4,5,11,9)
9. Relief valve leaks, (8,5,9)
10. Voltage to motor incorrect, (10,12,5)

REMEDY

- | REMEDY | INSTRUCTION |
|----------------------------------------------------|------------------------------------------------------------------------------------------------|
| 1. Check oil level | The oil level should be up to the bleed screw in the reservoir with the lift all the way down. |
| 2. Check/Tighten inlet tubes | Replace inlet hose assembly. |
| 3. Oil seal damaged or cocked | Replace oil seal and install. |
| 4. Bleed cylinders | See Installation Manual. |
| 5. See Installation Manual | Contact BendPak Customer Support. |
| 6. Check vehicle weight | Compare weight of vehicle to weight limit of the lift. |
| 7. Flush release valve | Hold release handle down and start unit allowing it to run for 15 seconds. |
| 8. Replace with new part | Replace with new part. |
| 9. Return unit for repair | Return unit for repair. |
| 10. Check motor is wired correctly | Compare wiring of motor to electrical diagram on power unit drawing. |
| 11. Inlet screen clogged | Clean inlet screen or replace. |
| 12. Check wall outlet voltage and wiring | Make sure unit and wall outlet is wired properly. |

IMPORTANT

If vehicle becomes stranded in the air, follow all operation instructions as shown on pages 27 - 31. If after observing that all mechanical locks are released and the lift still fails move following all standard operating procedures, immediately stop using the lift and contact factory or factory approved service center for further instructions.

LIFT WILL NOT STAY UP

POSSIBLE CAUSE



1. Air in oil, (1,2,3)
2. Check valve leaks, (6)
3. Cylinders leak internally, (7)
4. Lowering valve leaks, (4,5,1,7,6)
5. Leaking fittings, (8)

REMEDY

INSTRUCTION

- | | |
|-------------------------------------------------------|------------------------------------------------------------------------------------------------|
| 1. Check oil level | The oil level should be up to the bleed screw in the reservoir with the lift all the way down. |
| 2. Oil seal damaged and cocked | Replace oil seal around pump shaft. |
| 3. Bleed cylinder | Refer to Installation Manual. |
| 4. Flush release valve | Hold release handle down and start unit allowing it to run for 15 seconds. |
| 5. Replace with new valve | Replace with new valve. |
| 6. Return unit for repair | Return unit for repair. |
| 7. See Installation Manual | Contact BendPak Customer Support. |
| 8. Check complete hydraulic system for leaks. | Tighten all hydraulics fittings and inspects all hoses. |

Torque Recommendations

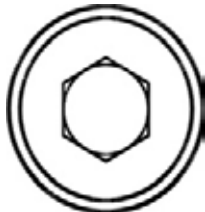
VALUES ARE STATED IN FOOT POUNDS (ft-lb)					
					
		SAE 0-1-2	SAE Grade 5	SAE Grade 8	SOCKET HEAD CAP SCREW
		CLASS 4.8	CLASS 8.8	CLASS 10.9	CLASS 12.9
Bolt Size (SAE)	Bolt Size (Metric)				
1/4-20	M6 x 1.0	6	10	14	13
5/16-18	M8 x 1.25	12	19	29	31.4
3/8-16	M10 x 1.50	20	33	47	62
7/16-14		32	54	78	
1/2-13	M12 x 1.75	47	78	119	108
9/16-12	M14 x 2.00	69	114	169	173
5/8-11	M16 x 2.00	96	154	230	269
3/4-10	M18 x 2.50	155	257	380	372
7/8-9	M22 x 2.50	206	382	600	716
3/4 Anchor Bolts		75 MIN 110 MAX			

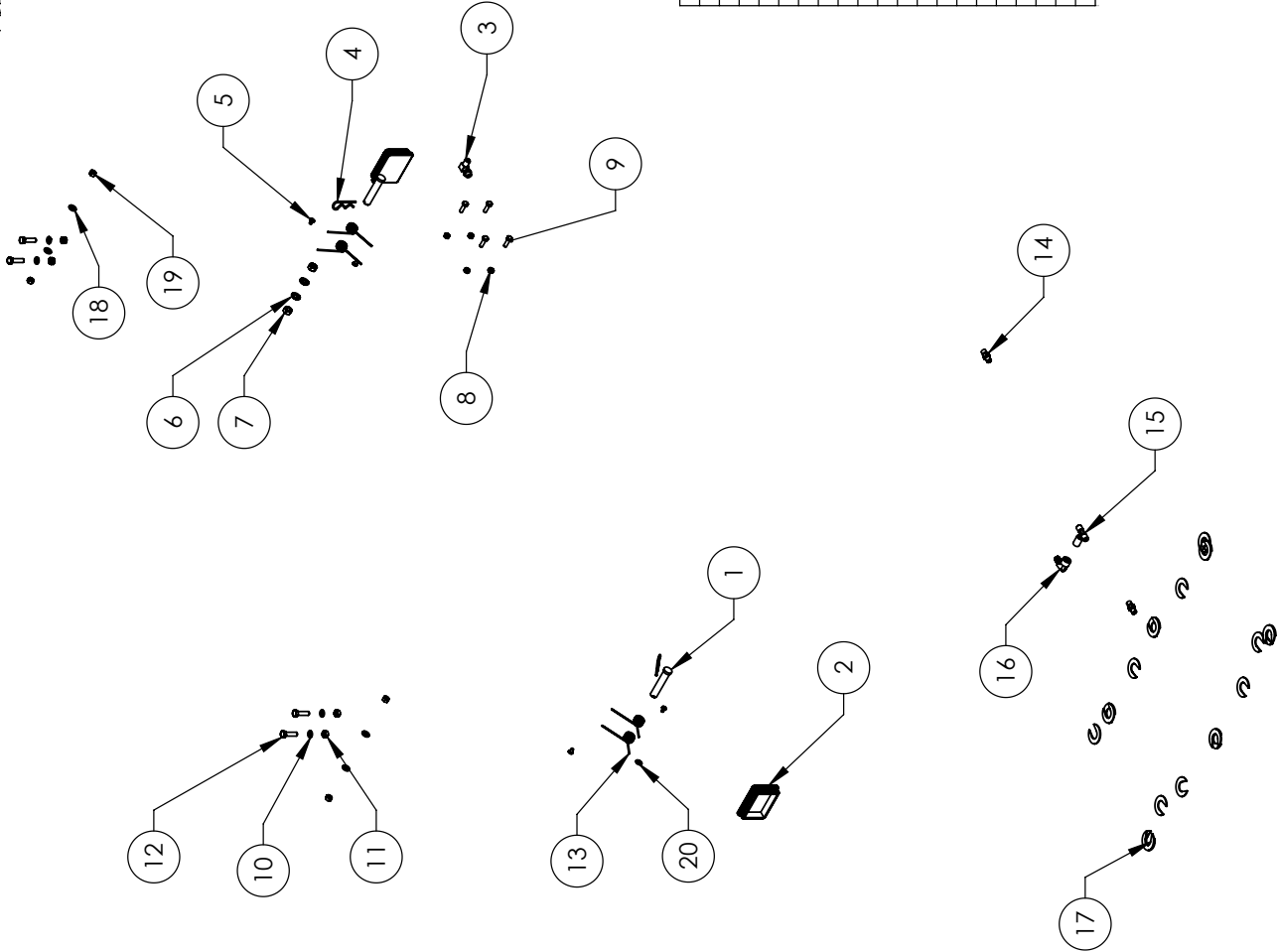

ITEM NO	PART NUMBER	DESCRIPTION	QTY	REV
1	5505001	GP-7/PL-6000/XPR SERIES SAFETY CLEVIS PIN	2	A
2	5715196	XPR PLASTIC COVER BLOCK 105 X 80	2	C
3	5550183	FTG ELB -06 JIC -06L ORB	1	-
4	5505350	MODEL#211 HAIR PIN/ LARGE	2	-
5	5530261	PHPS M6 x 1 x 10	4	-
6	5545347	WASHER M12 FLAT WASHER	2	-
7	5535354	NUT M12 x 1.75	2	-
8	5535001	NUT M8 x 1.25 NL	4	-
9	5530010	HHB M8 x 1.25 x 25	4	-
10	5545200	WASHER M10 x Ø18 SL	4	-
11	5535998	NUT M10 x 1.5	4	-
12	5530760	HEX HEAD BOLT M10x1.25x35	4	-
13	5540075	2.5 WIRE DIA., Ø20.5 x 75 LG	4	-
14	5550147	FIG NPL -04 JIC x -04 NPT	2	-
15	5550178	FTG TEE -04JIC -04JIC -06NPT	1	-
16	5550109	FTG ELB -06 JIC x -06 F NPT	1	-
17	5545355	C WASHER SHIM FOR LIFTS	20	-
18	5545341	WASHER M10 x Ø20 FLAT	4	-
19	5535013	NUT M10 x 1.5 NL	4	-
20	5505031	ROTOR CLIP 12mm SS	1	-

DATE
02/10/2010
02/19/2016

BendPak
1645 LEMONWOOD DR.
SANTA PAULA, CA 93060

TITLE:
XPR-9D/12FD PARTS BAG

SIZE DWG. NO. **A** 5174114

REV **H**

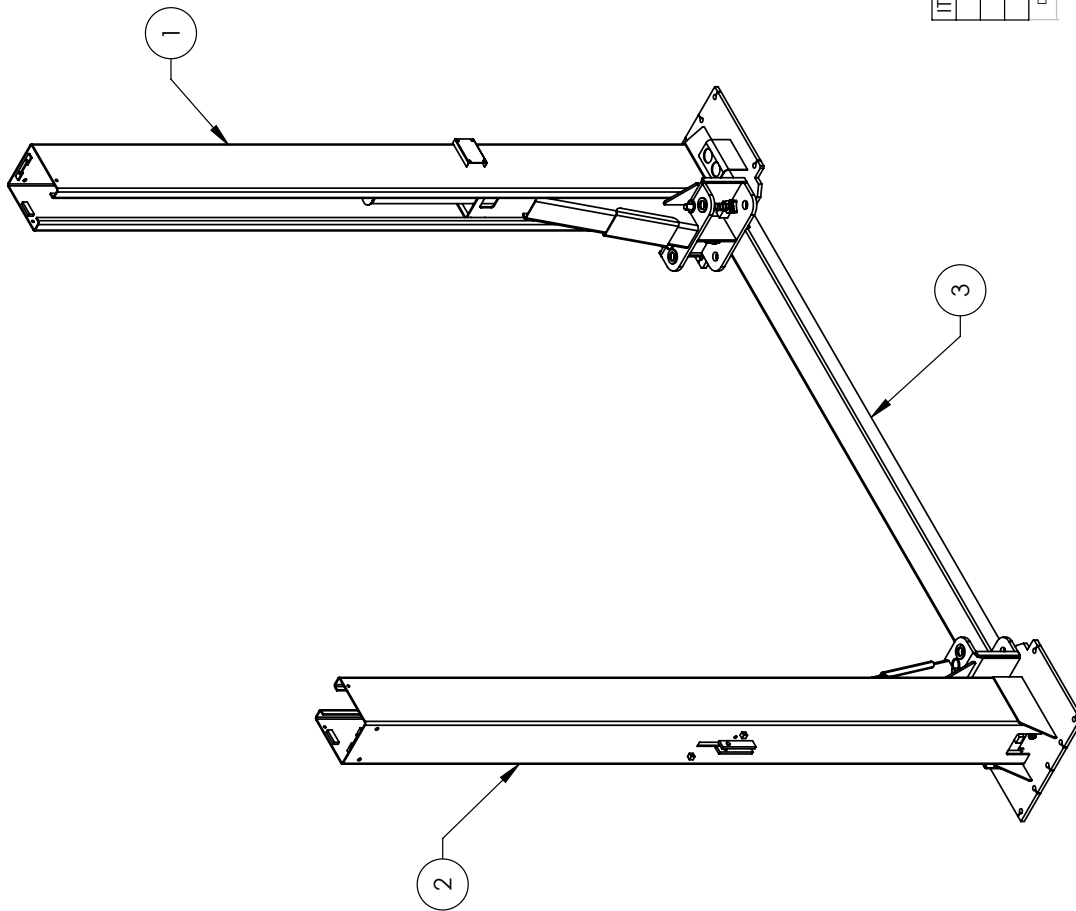

ITEM NO	PART NUMBER	DESCRIPTION	QTY	REV
1	5215356	XPR-12FD POWER SIDE POST ASSEMBLY	1	V
2	5215233	XPR-12FD OFF SIDE POST ASSEMBLY	1	U
3	5210047	XPR-12FD GROUND PLATE	1	C

DO NOT SCALE DRAWING		NAME	DATE
		TM	02/12/2010
		CA	02/23/2016

BendPak
1645 LEMONWOOD DR
SANTA PAULA, CA 93060

TITLE: XPR-12FD LIFT SUPERSTRUCTURE	
SIZE DWG. NO.	REV
A 5245137	V

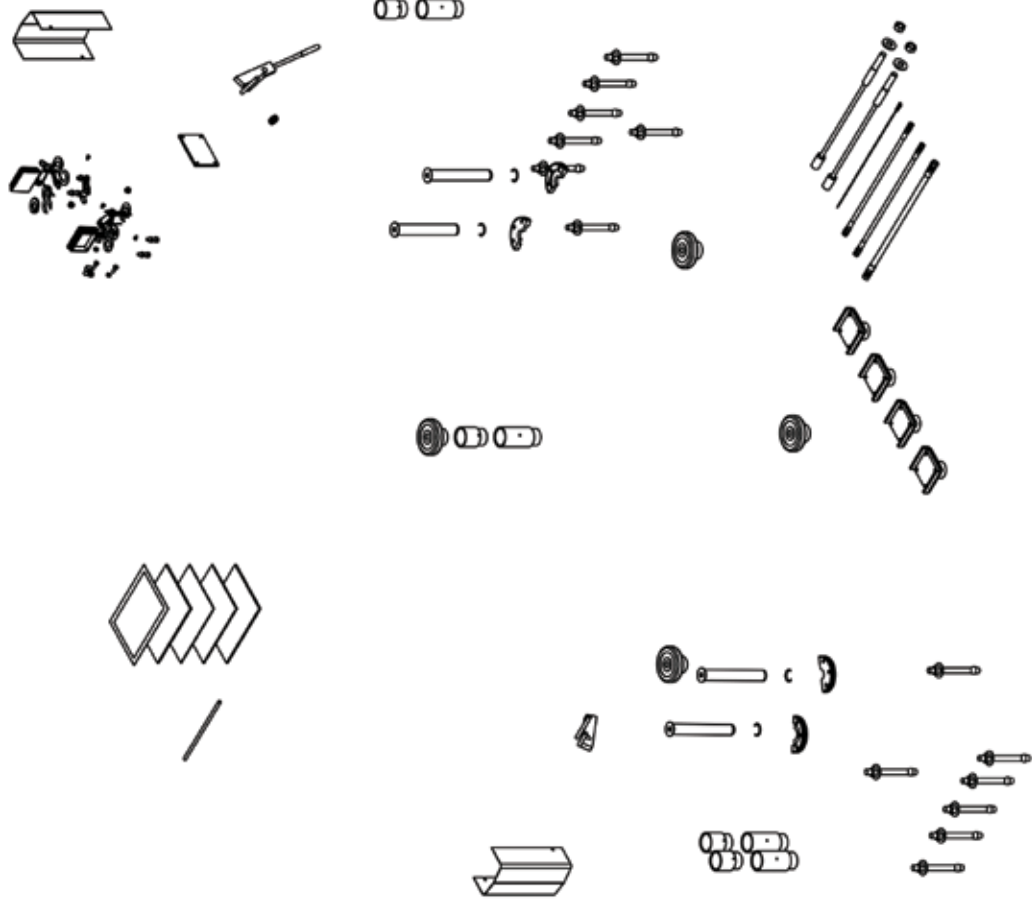

ITEM NO	PART NUMBER	DESCRIPTION	QTY	REV
1	5174114	XPR-9D/12FD PARTS BAG	1	H
2	5540281	C RING Ø38mm OD 5103-150	4	-
3	5210007	XPR POWER SIDE SAFETY ASSEMBLY	1	F
4	5210010	XPR OFF SIDE SAFETY WELDMENT	1	E
5	5715003	POWER UNIT VIBRATION DAMPENER	1	B
6	5215701	ROUND LIFT PAD ADAPTER ASSEMBLY	4	B
7	5736605	XPR-12 BOLT ON ARM RESTRAINT GEAR	4	E
8	5210009	XPR-9D/10/12/12FD/15/18C OFF SIDE SAFETY COVER	2	E
9	5746192	ARM ADAPTER, MEDIUM	4	-
10	5746193	ARM ADAPTER, LONG	4	C
11	5535011	NUT M22 x 2.5 NL	2	-
12	5545345	WASHER M22 x 50mm FLAT	2	B
13	5505346	XPR-12C/12FD LIFT HEAD PIN WELDMENT	4	B
14	5595124	XPR-12-FD Ø2.4 x 7400 SAFETY CABLE	1	B
15	5570118	XPR-12FD HYDRAULIC HOSE ASSEMBLY Ø6.35 x 1562mm DS	2	C
16	5595070	XPR-12FD CABLE ASSY Ø12 x 10800mm	2	B
17	5570126	XPR-12FD HYDRAULIC HOSE ASSY Ø10 x 3150mm DS	1	C
18	5746166	DOUBLE THREADED ROD M10 x 1.5 x 295	2	B
19	5530308	AB 3/4" x 7"	14	-
20	5215702	CRADLE LIFT PAD LARGE ADAPTER ASSEMBLY	4	C
21	5900280	ALI/LP FRAME ENGAGING LIFTS GUIDE	1	-
22	5900152	ALIGN OIM OPERATION INSPECTION & MAINTENANCE	1	-
23	5900147	SAFETY MANUAL ALI / SM 93-1	1	-
24	5905151	SAFETY TIPS CARD ALI-ST 90	1	-
25	5900952	XPR-12FD/12FDL-LWB INSTALLATION MANUAL	1	-

NAME	DATE
TM	12/15/2015

BendPak 1645 LEMONWOOD DR.
SANTA PAULA, CA 93060

TITLE: XPR-12FDL/12FDL-LWB
PARTS BOX

SIZE DWG. NO. **A** 5250042
REV **B**

BendPak 1445 LEMONWOOD DR.
 SANTA PAULA, CA 93060

TITLE: XPR-12FDL/12FDL-LWB
 PARTS BOX

SIZE	DWG. NO.	REV
A	5250042	B

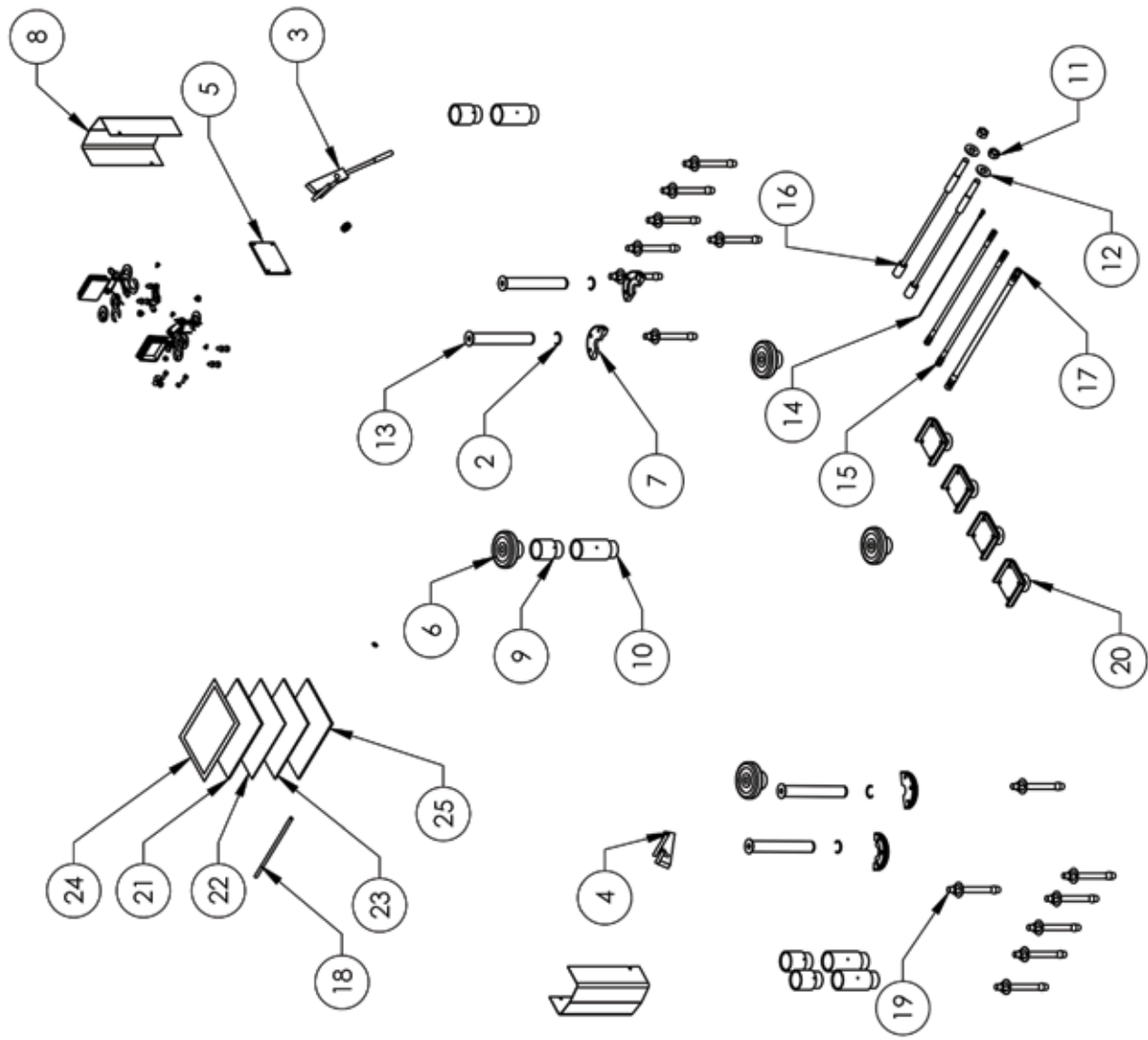

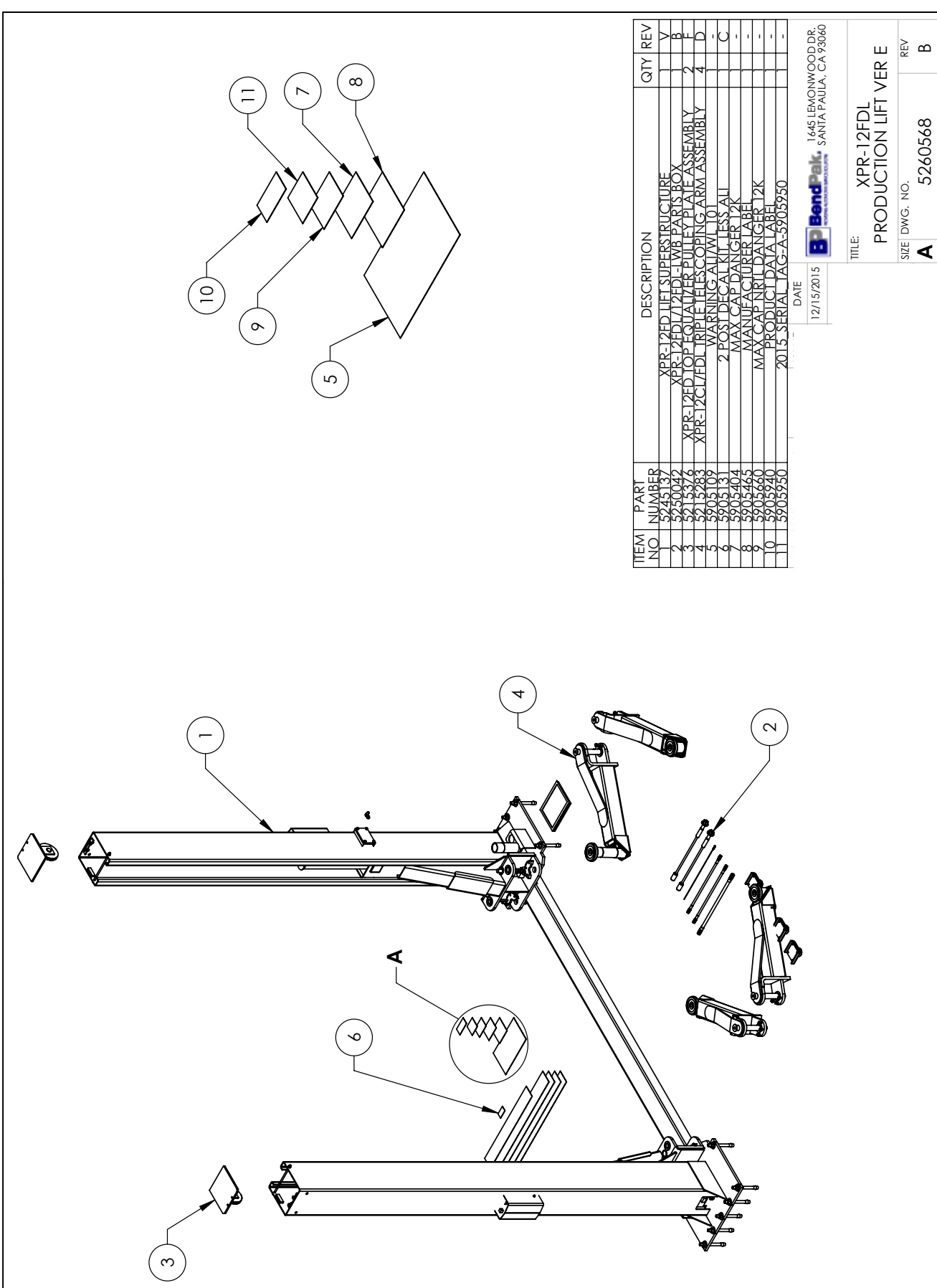

ITEM NO	PART NUMBER	DESCRIPTION	QTY	REV
1	5245137	XPR-12FDL LIFT SUPERSTRUCTURE	1	V
2	5250042	XPR-12FDL LIFT LWB PARTS BOX	1	B
3	5215376	XPR-12FDL TOP EQUIPMENT PULLEY PLATE ASSEMBLY	2	F
4	5215283	XPR-12CL/FDL TRIPLE TELESCOPING ARM ASSEMBLY	4	D
5	5205109	WARNING ARM/W/101	1	C
6	5205131	2 POST DECAL NUTLESS ALL	1	-
7	5205404	MAX CAP DANGER 12K	1	-
8	5205465	MANUFACTURER LABEL	1	-
9	5205660	MAX CAP NUT DANGER 12K	1	-
10	52059240	PRODUCT DATA LABEL	1	-
11	52059250	2015 SERIAL TAG-A-52059250	1	-

DATE: 12/15/2015
 1645 LEMONWOOD DR.
BendPak SANTA PAULA, CA 93660
 WWW.BENDPAK.COM

TITLE: XPR-12FDL
 PRODUCTION LIFT VER E
 SIZE DWG. NO. **A** 5260568
 REV **B**

BendPak
 1645 LEMONWOOD DR.
 SANTA PAULA, CA 93060

TITLE: XPR-12FDL
 PRODUCTION LIFT VER E

SIZE	DWG. NO.	REV
A	5260568	B

SCALE: 1:45 SHEET 2 OF 2

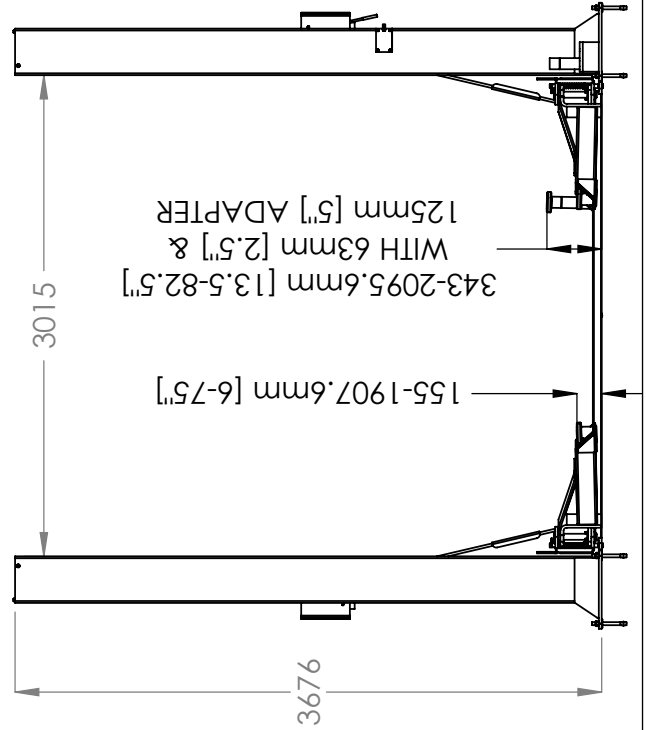
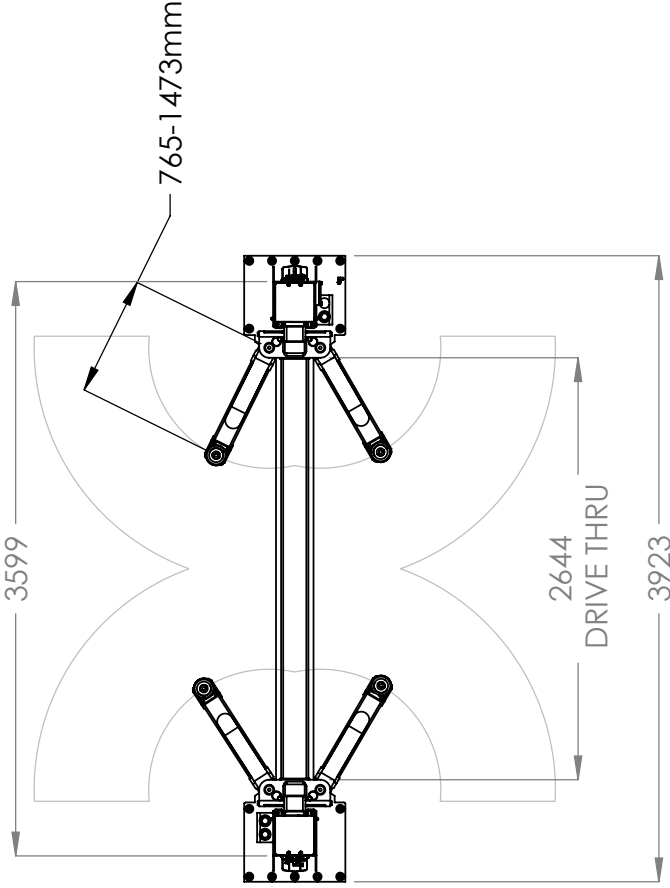



EC Type-Examination Certificate



(Fm 210-017, Rev.10)

For the requirements of the Machinery Directive 2006/42/EC

For Annex IV machinery

Certificate No.: CE-C-20120209-01-12-5D
Date of first issue: 2014.01.27
Date of last review: 2019.01.27
Date of next review: 2024.01.26

NAME AND ADDRESS OF THE MANUFACTURER: Bendpak Inc.
 1645 E. Lemonwood Drive, Santa Paula, CA, United States of America

PRODUCT DESCRIPTION/ TYPE AND MODEL: Range of 12,000lb (5443kg) 2 post vehicle servicing lift
 Floor plate (bottom bar) Direct drive
 XPR-12FDL 144H x 155W x 69 Lift in

APPLICABLE STANDARDS: EN1493:2010 Vehicle Lifts
 EN 60204-1:2006+A1:2009 Safety of machinery - Electrical equipment of machines - Part1:General requirements

A COPY IS AVAILABLE FROM: CCQS UK Ltd., 5 Harbour Exchange, London, E14 9GE, UK

RE-ISSUE HISTORY
 CE-C-20120209-01-12-5A first issue
 CE-C-20120209-01-12-5B reissued to rename XPR range
 CE-C-20120209-01-12-5C reissued with revised certificate template
 CE-C-20120209-01-12-5D This issue – 5 year review – No changes
 Delete discontinued model XPR-12FDL-LWB

The technical file, accompanying documentation and the equipment which they describe have been found to be in compliance with the requirements of the Machinery Directive 2006/42/EC.

The responsible person defined above has responsibility for ensuring that all future serial manufacture of the machinery conforms to the sample submitted for EC type-examination referenced above.

Any changes to the design of the machinery certified here must be advised to CCQS UK Ltd. for re-assessment.

A CE marking should not be fixed to the equipment until the requirements of all relevant directives have been met.

Approved by: Owen Bian – Office Manager

Date: 2019.01.27

Appointed by UK Government
 as a Notified Body
 for CE Marking No. 1105

CCQS UK Ltd.,
 5 Harbour Exchange, Canary Wharf,
 London, E14 9GE, UK
 Tel: +44 (0) 20 7868 1509
 Email info@ccqs.co.uk

If in any doubt about the integrity of this certificate,
 please verify it on our website at
<http://www.ccqs.co.uk>



Declaration of Conformity

The equipment which accompanies this declaration is in conformity with EU Directive:
2006/42/EC Machinery Directive

Manufacturer

BendPak Inc.
1645 Lemonwood Dr
Santa Paula Ca, 93060
USA

A copy of the Technical file for this equipment is available from:

CCQS UK Ltd., Level 7, Westgate House, Westgate Rd., London W5 1YY UK

Description of Equipment

Two-Column Vehicle Service Lift

XPR-12FDL	12K Cap. / Floorplate / Direct-Drive / Two-Post Lift	Serial Numbers 5175403-00000 to 99999-99999
XPR-12FDL-LWB	12K Cap. / Floorplate / Direct Drive/Long-Wheelbase Arms / Two Post Lift	Serial Numbers 5175404-00000 to 99999-99999

A sample of this machinery has been presented to Notified Body number 1105.

CCQS UK Ltd., Level 7, Westgate House, Westgate Rd., London W5 1YY UK

Who have issued an EC type-examination certificate number CE-GB-20150427-01-5A dated 2015.12.10.

The equipment in respect of which this declaration is made conforms to the example to which that certificate relates, and that certificate remains valid.

This declaration of conformity is issued under the sole responsibility of the manufacturer.

The following harmonised standards have been used:

EN1493:2010 Vehicle Lifts

Authorised signatory of manufacturer



Signature:

Name of signatory: Jeffrey S. Kritzer

Position in company: Senior Vice President of Marketing and Sales

Place signed: Santa Paula, CA, USA

Date signed: April 22, 2016



1645 Lemonwood Dr. ● Santa Paula, CA. 93060, USA
Toll Free: 1(800) 253-2363

FOR TECHNICAL SUPPORT
1-(800) 253-2363 Ext. 196
TO ORDER PARTS
1-(800) 253-2363 Ext. 191