

Two-Post Parking Lift

Installation and Operation Manual

Manual P/N 5900273 — Manual Revision A6 — July 2024

Models:

PL-6000DC

PL-6000DCX



*Original instructions in
the English language.*

Designed and engineered by BendPak Inc. in Southern California, USA. Made in China



IMPORTANT SAFETY INSTRUCTIONS, SAVE THESE INSTRUCTIONS! Read the entire contents of this Manual *before* installing, operating, servicing, or maintaining this product. Failure to follow the instructions and safety precautions in this Manual can result in serious injury or death. Make sure all other operators also read this Manual. Keep the Manual near the product for future reference. ***By proceeding with installation and operation, you agree that you fully understand the contents of this Manual and assume full responsibility for product use.***

Manual. PL-6000DC/DCX Parking Lift, *Installation and Operation Manual*, Manual P/N 5900273, Manual Revision A6, Released July 2024.

Copyright. Copyright ©2024 by BendPak Inc. All rights reserved. You may make copies of this document if you agree that: you will give full attribution to BendPak Inc., you will not make changes to the content, you do not gain any rights to this content, and you will not use the copies for commercial purposes.

Trademarks. BendPak and the BendPak logo are registered trademarks of BendPak Inc. All other company, product, and service names are used for identification only. All trademarks and registered trademarks mentioned in this Manual are the property of their respective owners.

Limitations. Every effort has been made to ensure complete and accurate instructions are included in this Manual. However, product updates, revisions, and/or changes may have occurred since this Manual was published. BendPak reserves the right to change any information in this Manual without incurring any obligation for equipment previously or subsequently sold. BendPak is not responsible for typographical errors in this Manual. The latest version of this manual is available at www.bendpak.com/manuals or by scanning the QR code.

Scan for digital pdf



Warranty. The BendPak warranty is more than a commitment to you: it is also a commitment to the value of your new product. Contact your nearest BendPak dealer or visit www.bendpak.com/support/warranty for full warranty details. Go to bendpak.com/support/register-your-product/ and fill out the online form to register your product (be sure to click Submit).

Safety. Your Lift was designed and manufactured with safety in mind. However, your safety also depends on proper training and thoughtful operation. Do not install, operate, maintain, or repair the unit without reading and understanding this Manual and the labels on the unit; **do not use your Lift unless you can do so safely!**

Owner Responsibility. In order to maintain your product properly and to ensure everyone's safety, it is the responsibility of the product owner to read and follow these instructions:

- Follow all installation, operation, and maintenance instructions.
- Make sure product installation conforms to all applicable local, state, and federal codes, rules, and regulations, such as state and federal OSHA regulations and electrical codes.
- Read and follow all safety instructions. Keep them readily available for operators.
- Make sure all operators are properly trained, know how to safely operate the unit, and are properly supervised.
- Do not operate the product until you are certain that all parts are in place and operating correctly.
- Carefully inspect the product on a regular basis and perform all maintenance as required.
- Service and maintain the unit only with approved replacement parts.
- Keep instructions permanently with the product and make sure all labels are clean and visible.
- **BendPak** makes no promises, guarantees or assurances that our products meet any state, county, federal or international mandated permit, license, code, standard, certification, or any other mandate other than what is listed or shown on BendPak website(s), or any BendPak or Ranger online or published catalog. Not all BendPak lift models meet the standards as prescribed by ANSI/ALI ALCTV-(current edition) or ANSI/UL 201. Consult www.autolift.org for a complete list of lift models that meet ANSI/ALI ALCTV-(current edition) or ANSI/UL 201 or contact BendPak via contact@bendpak.com. **Buyer assumes full responsibility for any state, county, federal or international mandated permit, license, code, standard, certification, or any other mandate required related to the installation and/or operation of any BendPak or Autostacker product.** BENDPAK will not be responsible for any charges, fines, liens, or other levies imposed on the Buyer related to any special or regional structural, seismic or any other building code and/or codes such as the Uniform Building Code (UBC), International Building Code (IBC), or any other state, county, federal or international mandated permit, license, code, standard, certification, or other mandate, law, rule, regulation or directive by any other agency, government, administrations, or corporations whether state, county, federal, or international mandated.

- **Only use the Lift if it can be used safely!**

Unit Information. Enter the Model Number, Serial Number, and the Date of Manufacture from the Label on your unit. This information is required for part or warranty issues.

Model: _____

Serial: _____

Date of Manufacture: _____

BP BendPak.		Santa Paula, CA USA www.bendpak.com
MODEL NUMBER		
DESCRIPTION		
LIFT CAPACITY	DATE CODE	
VOLTAGE		SERIAL NUMBER
<input type="checkbox"/> 110-120V, 50-60 Hz, 1 Ph <input type="checkbox"/> 208-240V, 50-60 Hz, 1 Ph <input type="checkbox"/> 380-415V, 50-60 Hz, 3 Ph <input type="checkbox"/> 208-440V, 50-60 Hz, 3 Ph		UPC
 DANGER! Disconnect Power Before Servicing		EAC
MADE IN CHINA	WARRANTY VOID IF DATA PLATE IS REMOVED	PN 5905951



Table of Contents

Introduction	4	Operation	57
Shipping Information	5	Maintenance	61
Safety Considerations	5	Troubleshooting	65
Components	8	Multiple Lift Installations	69
FAQs	9	Wiring Diagram	73
Specifications	10	Labels	79
Will My Car Fit?	11	Parts Drawings	82
Orientation	13	American Lift Institute (ALI)	93
Installation Checklist	14	Maintenance Log	94
Installation	15		

Introduction

This Manual describes the PL-6000DC and PL-6000DCX Two-Post Parking Lifts designed to accommodate most cars and light trucks. The platform supports up to 6,000 lbs. (2,722 kg) and is designed for indoor locations only.

PL-6000DC – Supports up to 6,000 lbs. (2,722 kg) with a usable platform width of 82.5 in. (2,100 mm).

PL-6000DCX - Supports up to 6,000 lbs. (2,722 kg) with a usable platform width of 94.5 in. (2,400 mm).

The PL-6000DC/DCX can accommodate multiple side-by-side installations by sharing a Lift Post between lifts. Each Lift requires a dedicated Power Unit. See the **Multiple Lift Installations** section for more information. More information about the full line of BendPak products can be found at bendpak.com.

This Manual is mandatory reading for all users of PL-6000DC/DCX Lifts, including anyone who installs, uses, maintains, or repairs them.

 DANGER Be extremely careful when installing, operating, maintaining, or repairing this equipment; failure to do so could result in property damage, product damage, injury, or (in very rare cases) death. Make sure only authorized personnel operate this equipment. All repairs must be performed by an authorized technician. Do not make modifications to the unit; this voids the warranty and increases the chances of injury or property damage. Make sure to read and follow the instructions on the labels on the unit.

Keep this Manual on or near the equipment so that anyone who uses or services it can read it. If you are having issues, refer to the **Troubleshooting** section of this Manual for assistance.

Technical support and service is available from your dealer, on the Web at bendpak.com/support, by email at support@bendpak.com, or by phone at **(800) 253-2363** follow the prompts to reach support or sales.

Shipping Information

Your equipment was carefully checked before shipping. Nevertheless, you should thoroughly inspect the shipment **before** you sign to acknowledge that you received it.

When you sign a bill of lading, it tells the carrier that the items on the invoice were received in good condition. *To protect yourself, do not sign until **after** you have inspected the shipment.* If any of the items listed on the bill of lading are missing or are damaged, do not accept the shipment until the carrier makes a notation on the bill of lading that lists the missing and/or damaged goods.

If you discover missing or damaged goods **after** you receive the shipment and have signed the bill of lading, notify the carrier at once and request the carrier to make an inspection. If the carrier will not make an inspection, prepare a signed statement to the effect that you have notified the carrier (on a specific date) and that the carrier has failed to comply with your request.

It is difficult to collect for loss or damage after you have given the carrier a signed bill of lading. If this happens to you, file a claim with the carrier promptly. Support your claim with copies of the bill of lading, freight bill, invoice, and photographs, if available. Our willingness to assist in helping you process your claim does not make us responsible for collection of claims or replacement of lost or damaged materials.

Safety Considerations

Read this Manual carefully before installing or using your new product. Do not install or operate the product until you are familiar with all operating instructions and warnings. Do not allow anyone else to operate it until they are familiar with all operating instructions and warnings. Keep this Manual on or near the product for future reference.

 **WARNING California Proposition 65.** This product can expose you to chemicals including styrene and vinyl chloride which are on the list of over 900 chemicals identified by the State of California to cause cancer, birth defects or reproductive harm. Always use this product in accordance with BendPak's instructions. For more information, visit www.p65warnings.ca.gov.

Important Safety Information

When using this equipment, basic safety precautions should always be followed, including:

- Read all instructions. Use only as described in this manual.
- Only operate your Lift between temperatures of 41°F to 104°F (5°C to 40°C).
- Make sure all operators read and understand this *Installation and Operation Manual*. **Keep this manual near the Lift at all times.**
- The Lift should only be operated by authorized personnel. Keep children and untrained personnel away from the Lift.
- Do not make any modifications to the Lift; this voids the warranty and increases the chances of injury or property damage. Use only factory-approved attachments. **Do not modify any safety related features in any way.**
- Do not use the Lift while tired or under the influence of drugs, alcohol, or medication.
- Do not touch hot parts; you could be burned. Always use care with the equipment.

-
- Do not operate equipment with a damaged cord or if the equipment has been dropped or damaged – until it has been examined by a qualified service person.
 - Do not let a cord hang over the edge of a table, bench, or counter or come in contact with hot manifolds or moving fan blades. Loop the power cord around equipment when storing.
 - If an extension cord is necessary, a cord with a current rating equal or greater than that of the equipment should be used. Cords rated for less current than the equipment may overheat. Care should be taken to arrange the cord so that it will not be tripped over or pulled out.
 - Always unplug equipment from electrical outlets when not in use. Never use the cord to pull the plug from the outlet. Grasp plug and pull to disconnect.
 - To reduce the risk of a fire, do not operate equipment in the vicinity of open containers of flammable liquids (like gasoline).
 - Adequate ventilation should be provided when working on operating internal combustion engines.
 - Keep hair, loose clothing, fingers, and all parts of the body away from moving parts.
 - To reduce the risk of electric shock, do not use the unit on wet surfaces or expose to rain.
 - **Always wear safety glasses!** Everyday glasses only have impact resistant lenses, they are not safety glasses.

Save these instructions!

Additional Safety Information

The following safety information applies to all BendPak PL-6000DC/DCX Parking Lifts:

- PL-6000DC Lifts are Parking Lifts. **Use them only for their intended purpose.**
- The Lift should only be operated by authorized personnel. Keep children and untrained personnel away from the Lift.
- You must wear OSHA-approved (publication 3151) personal protective equipment at all times when installing, using, maintaining, or repairing the Lift. Leather gloves, steel-toed work boots, eye protections, back belts, and hearing protection are **mandatory**.
- **Never** exceed the rated capacity of the Lift.
- When the Lift is in use, keep hands and all body parts well away from it.
- Keep loads balanced on the Lift Platform. Clear the area immediately if a Vehicle is in danger of falling off the Lift. Do not make modifications to the Lift.
- The Lift uses electrical energy; if your organization has Lockout/Tagout policies, make sure to implement them after connecting the Lift to a power source.
- When handling the Hydraulic components, **always wear safety gloves!** In rare cases, a needle-like stream of Hydraulic Fluid (even at low pressure) can penetrate fingers, hands, or arms. Such a puncture can feel like a bite, electric shock, or a needle prick. While it may seem like a minor issue, any amount of Hydraulic Fluid injected into the human body is a serious issue. Anyone suffering such a puncture wound should be **immediately** taken to a hospital emergency to determine the extent of the injury. Explain the circumstances of the injury to the attending physician, including what type of Hydraulic Fluid was involved. Do not assume a puncture wound that could have been caused by Hydraulic Fluid is a minor issue; it could be life-threatening.
- Make a visual inspection of the Lift before using it. Do not use the Lift if you find any missing or damaged parts. Instead, take it out of service, then contact an authorized repair facility, your distributor, or BendPak at **(805) 933-9970** or email support@bendpak.com.
- BendPak recommends making a **thorough** inspection of the Lift at least once a year. Replace any damaged or severely worn parts, decals, or warning labels.

Symbols

Following are the symbols used in this Manual:

 **DANGER** Calls attention to an immediate hazard that **will** result in death or severe injury.

 **WARNING** Calls attention to a hazard or unsafe practice that **could** result in death or severe personal injury.

 **CAUTION** Calls attention to a hazard or unsafe practice that could result in minor personal injury, product damage, or property damage.

NOTICE Calls attention to a situation that, if not avoided, could result in product or property damage.

Liability Information

BendPak Inc. assumes **no** liability for damages resulting from:

- Use of the equipment for purposes other than those described in this Manual.
- Modifications to the equipment without prior, written permission from BendPak.
- Modifying, disabling, overriding, or removing safety features.
- Damage to the equipment from external influences.
- Incorrect operation of the equipment.

Components

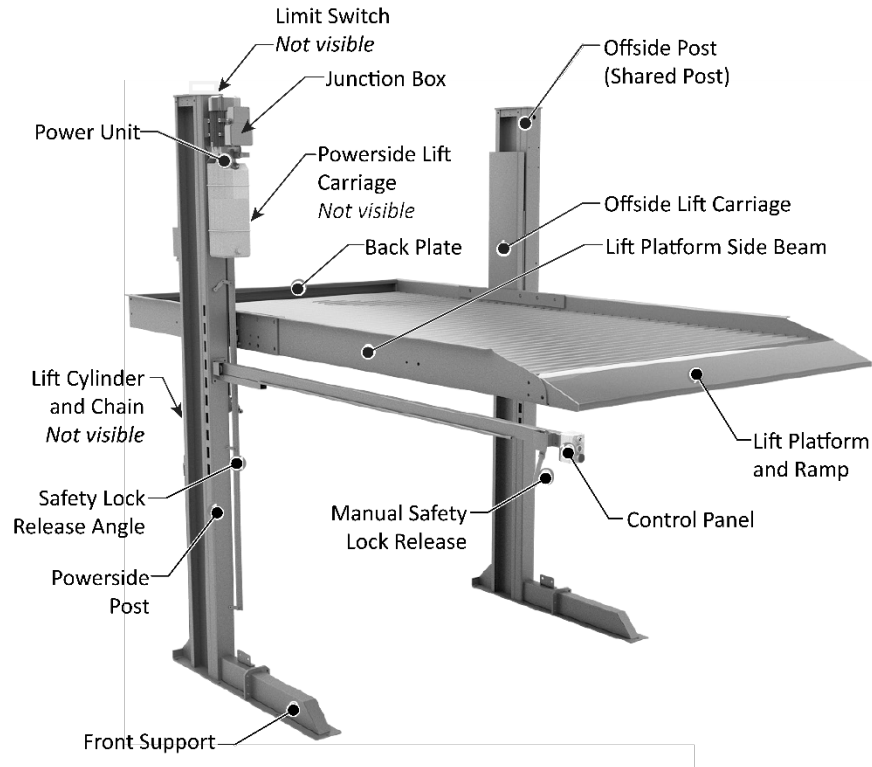

The components of your Lift include:

- **Lift Platform and Ramp.** The metal surface that holds raised Vehicles.
- **Control Panel.** Houses the Key Switch, Power Indicator, and Emergency Stop controls.
- **Manual Safety Lock Release.** Releases the Safety Locks to Lower the Lift Platform.
- **Front Support.** A bolt-on section of the Lift Post support.
- **Powerside Post.** The Post (sometimes called a column), on which the Power Unit is mounted.
- **Safety Lock Release Angle.** A section of the Safety Lock Release mechanism.
- **Hydraulic Cylinder.** Drives the Lift Chain to raise and lower the Lift Platform.
- **Power Unit.** Provides hydraulic power to the Hydraulic Cylinders that raise and lower the Lift Platforms.
- **Junction Box.** Mounted on the Power Unit. Houses the wiring and electrical controls for the Lift.
- **Limit Switch.** Limits the upward travel of the Lift.
- **Lift Carriage.** Rides up and down in the Lift Post driven by a Lift Chain. Attaches to the Lift Platform.
- **Offside (Shared) Post.** The Offside Post is opposite the Powerside Post. When installing multiple Lifts next to each other, the Offside Post becomes the **Shared Post**. The Shared Post for the first Lift becomes the Powerside Post for the second Lift.
- **Powerside and Offside Lift Carriages.** Lift Carriages move up and down in the Lift Posts. The Carriages are connected to the Lift Platform.
- **Lift Platform Side Beam.** Part of the structure connecting the Lift Carriage to the Lift Platform.
- **Back Plate.** Limit of Vehicle travel on the Lift Platform.

Frequently Asked Questions

Question: What kinds of Vehicles may be parked on the PL-6000DC Lift?

Answer: Cars, light trucks, and SUVs; up to 6,000 lbs. (2,722 kg) per Platform. The vehicle's Wheels must fit on the 82.5 in (2,100 mm) x 146 in. (3,700 mm) Lift Platform.

Q: What kinds of Vehicles may be parked on the PL-6000DCX Lift?

A: Cars, light trucks, and SUVs; up to 6,000 lbs. (2,722 kg) per Platform. The vehicle's Wheels must fit on the 94.5 in (2,400 mm) x 146 in. (3,700 mm) Lift Platform.

Q: Does the Lift have to be anchored in place?

A: Yes. The Lift Posts **must** be anchored.

Q: Can I install my Lift outside?

A: The Lift is designed for indoor installation only. **Outdoor installation is prohibited.**

Q: Can the Lift be used to store boxes of stuff instead of a Vehicle?

A: No. The Lift is *not* designed to be used in this manner.

Q: How high does my garage ceiling have to be?

A: It depends on the height of the Vehicles you are putting on the Platforms. If you are parking low-slung Vehicles, then your ceiling does not have to be as high as it would need to be if you are parking taller Vehicles. Refer to Height Requirements and [Will My Car Fit?](#) for additional information.

Q: Does the Control Panel have to be connected to the Powerside Post?

A: Yes. That location gives the operator a clear view of the Platforms as they are raised and lowered.

Q: Does it matter if I drive my Vehicles in front first or back them in?

A: No. The Lift works great either way. Make sure to park all Vehicles in the middle of the Platform, no matter which way you drive them in. All four wheels must be completely on the Lift Platform. Do not park the Vehicle's Wheels on the Ramp, the Back Stop, or the Side Beams.

Q: How long can I leave a Vehicle on a raised Platform?

A: Indefinitely **if the Platform rests on a Safety Lock.** Once a Safety Lock is engaged, gravity holds it in position, so a loss of power does not impact the Lift. Your Vehicle is going to stay where you left it. Remember to **always leave the Platform either on the ground or engaged on a Safety Lock.**

Specifications

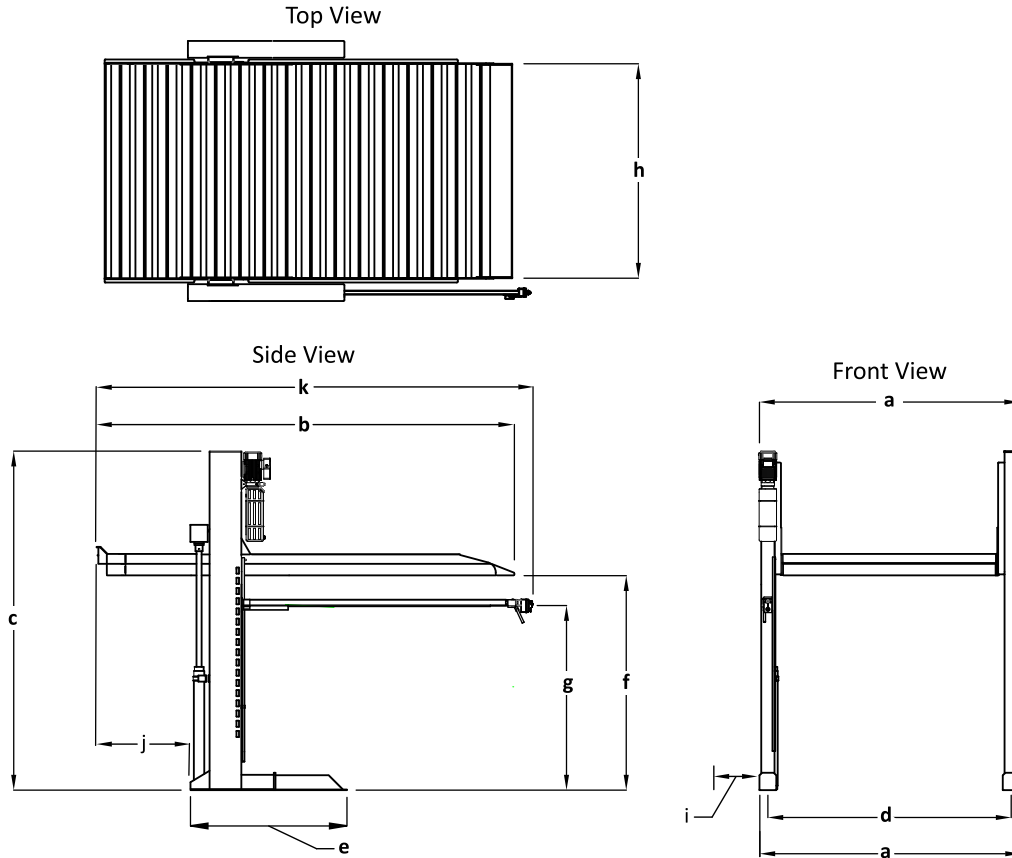

Model	PL-6000DC	PL-6000DCX
Lifting capacity per Platform	6,000 lbs. (2,700 kg)	6,000 lbs. (2,700 kg)
a Total width, outside edge to outside edge	100.25 in. (2,547mm)	112 in. (2,847 mm)
b Lift Platform Length	157 in. (3,990 mm)	
c Post height; *See note 1	131 in. (3,320 mm)	
d Post, center to center width	93.75 in. (2,382 mm)	105.5 in. (2,682 mm)
e Post Support Length	60.25 in. (1,532 mm)	
f Lifting height	82.5 in. (2,100 mm)	
g Control Column Height	71 in. (1,805 mm)	
h Lift Platform (Usable Width)	82.5 in. (2,100 mm)	94.5 in. (2,400 mm)
i Side Clearance min.	2 in. (50.75 mm)	
j Platform to Support	36.25 in. (918.25 mm)	
k Length Overall	163.5 in. (4,152.5 mm)	
Lifting Time	<50 Seconds	
Motor	208-240V, 50/60HZ, 1-Ph., 4 HP, 22 Amps	
Operating Temperature and Humidity	+41° to +104°F / +5° to +40°C 50% RH	

*Note 1. Balance Chain adjustment adds up to 2.25 in. (57 mm) above the Post height.

Specifications subject to change without notice.

Side View

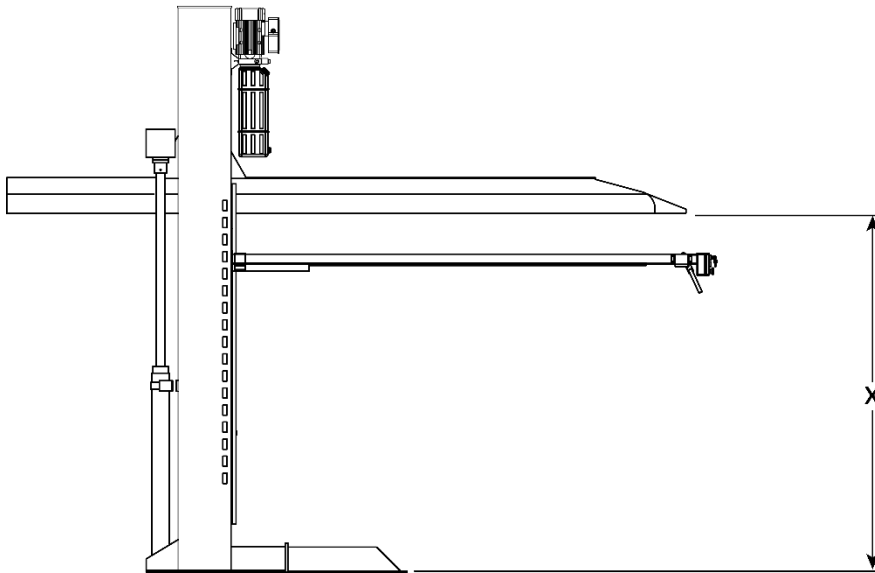

Locking Positions PL-6000DC/DCX		
Position (X)	Inches	Millimeters
1	45	1,143
2	48.9	1,243
3	52.8	1,343
4	56.8	1,443
5	60.7	1,543
6	64.6	1,643
7	68.6	1,743
8	72.5	1,843
9	76.4	1,943
10	80.4	2,043

Will My Car Fit?

Your Lift accommodates a wide variety of cars, light trucks, and SUVs.

Width

Considerations for Vehicle width include:

- **Platform width.** The outside dimension of your tires cannot be wider than listed above. All four tires must rest fully on the Platform; they cannot be ride on the side structure or on the Drive-up Ramp. Always center your Vehicles on the Platform.
- **Mirrors.** Mirrors and other accessories may mean that some parts of a Vehicle are much wider than the rest of the Vehicle. Parking lifts are designed to have lots of open space, but if you are parking Vehicles next to each other that both have wide mirrors or other accessories, verify they do not hit each other.
- **Car doors.** Opening Vehicle doors makes the Vehicle wider while they are open. Generally, you want to avoid opening the doors of multiple Vehicles parked next to each other at the same time. You cannot open a car door while the Vehicle is raised, so this is not an issue for raised Vehicles.

PL-6000DC	82.5 in. (2,100 mm)
PL-6000DCX	94.5 in. (2,400 mm)

Length

Considerations for Vehicle length include:

- **Platform length.** The usable length of the Platform is **146 inches (3,700 mm)**; your wheelbase cannot be longer than this. **All four tires must rest fully on the Platform**; they cannot be on the Ramp or beyond the Tire Stop.
- **Overhang.** If a Vehicle's tires are fully on the Platform, then the parts of the Vehicle hanging over the Back Stop or the Ramp are not a concern, as long as they do not hit the Lift Posts or any other obstruction.

Height

Considerations for Vehicle height include:

- **Ceiling height.** A typical ceiling height as shown in the figure below is approximately **170 inches (4,320 mm)**. The height of your ceiling determines how much space you can allocate to the two Vehicles. If you want to park a tall Vehicle on a Platform *and* under the Platform, your ceiling is going to have to be higher than if you want to park two low-slung Vehicles.

Typical Height Requirements

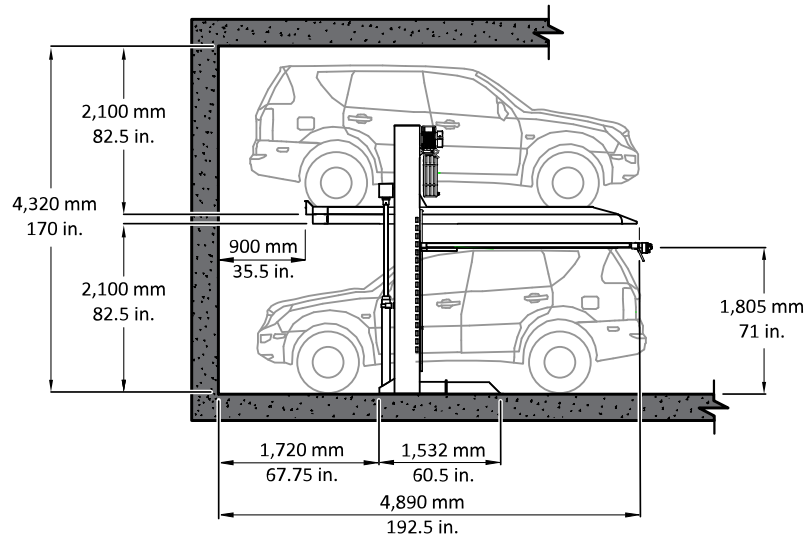

Orientation

The Front of your Lift is the Approach.

In the case of the PL-6000DC/DCX, the Power Unit and Powerside Post are on the left when viewed from the Approach.

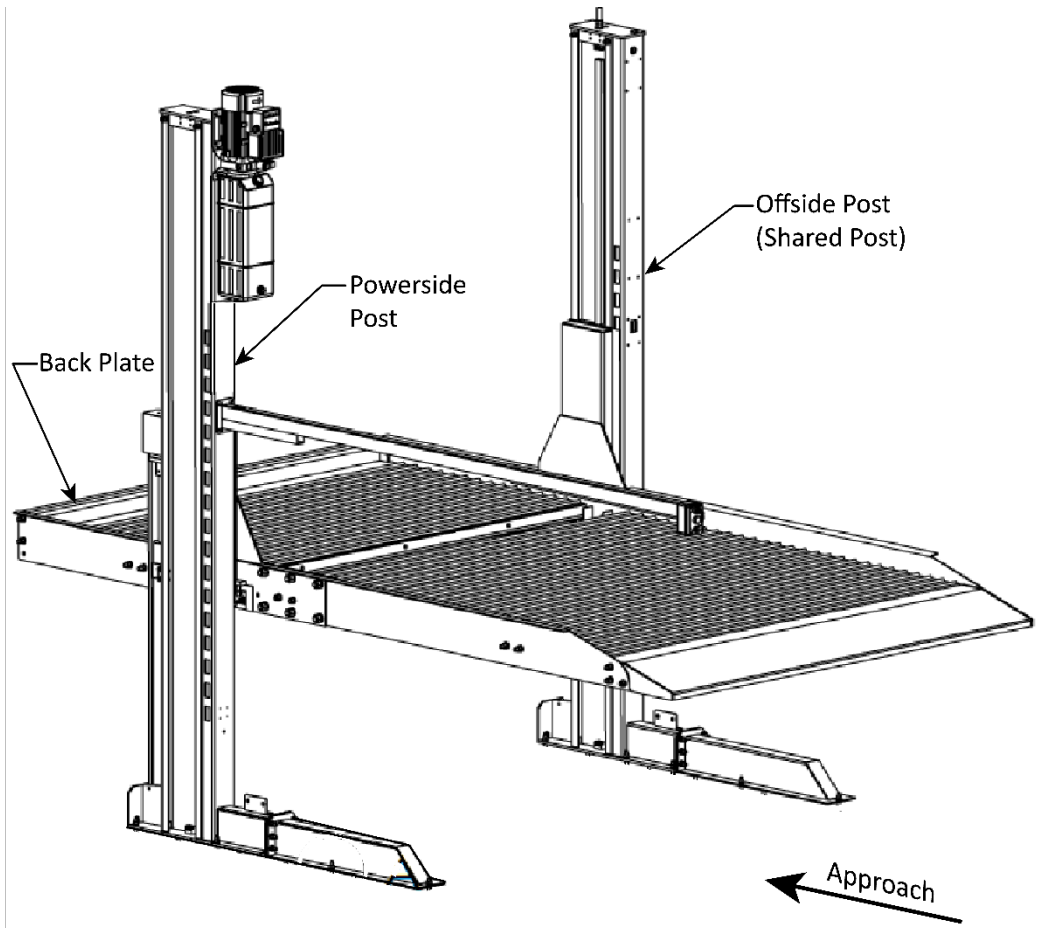

Installation Checklist

Following are the steps needed to install a PL-6000DC/DCX Lift. Perform them in the order shown.

- 1. Review the installation Safety rules.
- 2. Make sure you have the necessary Tools.
- 3. Plan for electrical work.
- 4. Select the installation Location.
- 5. Checking clearances.
- 6. Unload and unpack the Lift Components.
- 7. Review the installation orientation.
- 8. Create Chalk Line Guides for the Posts.
- 9. Move and Prepare the Lift Posts.
- 10. Anchoring the Powerside Post.
- 11. Attach the Side Beams, Back Plate and Connection Rods.
- 12. Route and attach the Balance Chain.
- 13. Connecting the Safety Lock Release – Lift Carriages.
- 14. Installing the Lift Cylinder and Lift Chain.
- 15. Install the Power Unit.
- 16. About Thread Sealants.
- 17. Install the Safety Lock Release Angle.
- 18. Installing the Control Arm.
- 19. Connect the Safety Lock Release Cable.
- 20. Installing the Lift Platform Plates and Ramp.
- 21. Contact an Electrician.
- 22. Install the Safety Lock Release Angle.
- 23. Install the Power Disconnect and Thermal Disconnect (if required). (**Electrician Required**).
- 24. Connect to Power (**Electrician Required**).
- 25. Wire the Junction Box (**Electrician Required**).
- 26. First Operational Test and Level Adjustment.
- 27. Adjusting the Safety Locks and Safety Release.
- 28. Adjusting the Limit Switch.
- 29. Drill the Offside Post Anchors and Attach the Front Supports.
- 30. Lubricate the Lift.
- 31. Perform an Operational Test.
- 32. Review the Final Checklist.
- 33. Leave the Manual for the Lift Owner/Operator.

Installation

The installation process includes multiple steps. Perform them in the order listed.

⚠ WARNING **Only use the factory-supplied parts that came with your Lift.** If you use parts from a different source, you void your Warranty and compromise the safety of everyone who installs or uses the Lift. If you are missing parts, visit bendpak.com/support or call **(800) 253-2363**, follow the prompts to reach support.

Safety

While installing this equipment, your safety depends on proper training and thoughtful operation.

⚠ WARNING Do not install this equipment unless you have automotive Lift installation training. Always use proper lifting tools, such as a Forklift or Shop Crane, to lift heavy components. Do not install this equipment without reading and understanding this Manual and the Labels on the unit.

Only fully trained personnel should be involved in installing this equipment. Always pay attention. Use appropriate tools and lifting equipment. Stay clear of moving parts.

⚠ WARNING You **must** always wear OSHA-approved (publication 3151) appropriate protective equipment during installation: leather gloves, steel-toed work boots, eye protection, back belts, and hearing protection are **mandatory**.

Tools Required

You may need some or all of the following tools:

- Rotary hammer drill (or similar)
- 12 mm carbide bit (conforming to ANSI B212.15)
- Hammer and crowbar
- Four-foot level
- Open-end wrench set, metric
- Socket and ratchet set, metric
- Hex key wrench set, metric
- Medium crescent wrench
- Torque wrench
- Phillips and slotted screwdrivers
- Hammer
- Chalk line
- Medium-sized flat screwdriver
- Tape measure, 25 feet or above
- Needle-nose pliers
- Forklift, or Shop Crane 2 Ton capacity
- White Lithium Grease
- Machine oil for Chain lubrication
- Thread Sealant

Planning for Electrical Work

You will need to have a licensed, certified Electrician available at some point during the installation.

Notify your Electrician in advance so that they come prepared with appropriate wiring for connecting the Power Unit to the power source, through a Power Disconnect Switch, and are prepared to wire the Junction Box, and Solenoid. Refer to **Contact an Electrician** for more information.

NOTICE Power wiring to the Lift as well as the Disconnect Switch itself must be provided by the Electrician; it is **not** supplied with the Lift.

⚠ DANGER All wiring **must** be performed by a licensed, certified Electrician. Verify all electrical work conforms to all applicable local and federal codes, rules, and regulations, such as state and federal OSHA regulations and electrical codes.

The Electrician needs to:

- **Connect a 220 VAC power source** to the Power Disconnect Switch and to the Junction Box.
- **Connect the Junction Box Wiring.** The Junction Box is the connection point for the controls, the Solenoid, Power, and Relays for the Lift.

Select a Location

When selecting the location for your Lift, consider:

- **Architectural plans.** Consult the architectural plans for your desired installation location. Verify no conflicts exist between what you want to do and what the architectural plans detail.
- **Available space.** Verify there is enough space for the Lift: front, back, sides, and above. Refer to **Checking Clearances** below and **Specifications** for measurements.
- **Overhead obstructions.** Check for overhead obstructions such as building supports, heaters, electrical lines, low ceilings, hanging lights, and so on. **You do not want your Vehicles hitting obstructions.**
- **Power.** You need access to a 220 VAC single phase power source for the Power Unit.
- **Outdoor installations.** PL-6000DC Lifts are **not** designed to be installed outdoors. **Outdoor installation is prohibited.**
- **Shimming.** If your Concrete floor is not level, you can use Shims under the bases of the Posts, to level the Lift. To estimate your Shim requirements, use a transit level and targets to check for flatness. Use the Shims if necessary.

Important: Do not shim a Post more than half an inch.

- **Floor.** Only install the Lift on a level, concrete floor; do not install on asphalt or any other surface. The Concrete floor where you install your Lift must meet the following requirements:
 1. 6 in. (150 mm) thick, steel reinforced with a compressive strength of 4,350 psi and cured for a minimum of 28 Days.
 2. The Pre-Existing Concrete Floor **must** be test drilled to determine the actual thickness of the Concrete at the location you wish to install the lift.
 3. The floor must be a flat, and level; **do not install the Lift on a surface with a slope of more than 1% (0.57°).**

 **WARNING** Installing your Lift on a surface with more than a 1% slope (0.57°) could lead to injury or even death. Only install the PL-6000DC Lift on a level floor. If your floor is not level, consider making the floor level by cutting, removing, and creating a new concrete slab or choosing a different location.

4. Do not install the Lift on cracked or defective Concrete.
5. **Never** install the Lift over Concrete expansion or control joints of any kind.
6. All Anchors **must** be a minimum of 6 in. (152 mm) away from any expansion seams, control joints or other inconsistencies in the Concrete.
7. **Never** install a Lift on hand-mixed Concrete.
8. Do **not** install a Lift on a secondary floor level or on any ground floor with a basement beneath without written authorization from the building Architect and prior approval of Bend Pak Inc.
9. Verify the floor is **not** a post-tension slab. If it is a post-tension slab, contact the building architect before drilling. Using ground penetrating radar may help you find the tensioned cables.
10. On Post-tension slabs, a qualified technician is required to identify cable locations prior to cutting or drilling. If there are no signs indicating a Post-Tension Slab, undertake a careful examination of the exterior of the slab looking for small circular patching areas about 1.5 in. to 3 in. in diameter, typically 2 to 4-feet apart. These patches indicate the ends of the Post-Tensioned Cables. Another source of information is your local department of Building and Safety. Structural plans may be retrieved by Building and Safety to determine if the building has a Post-Tensioned Slab.

 **WARNING** Cutting through a Post-Tensioned Cable can result in injury or death. Do not drill into a post-tension slab unless the building architect confirms you are not going to hit tensioned steel, or you have located it using ground penetrating radar. If a colored sheath comes up during drilling, stop drilling immediately.

 **WARNING** Use only the Anchor Bolts that came with your Lift. If you use components from a different source, you void your warranty and compromise the safety of everyone who installs or uses the Lift.

 **CAUTION** BendPak Lifts are supplied with installation instructions and concrete anchors that met the criteria set by the latest version of the American National Standard “Automotive Lifts – Safety Requirements for Construction, Testing, and Validation”, ANSI/ALI ALCTV. You are responsible for any special regional structural and/or seismic anchoring requirements specified by any other agencies and/or codes such as the Uniform Building Code (UBC) and/or International Building Code (IBC).

Checking Clearances

A minimum of clear space around the lift is required for safety, service access and maintenance. Refer to the figure below.

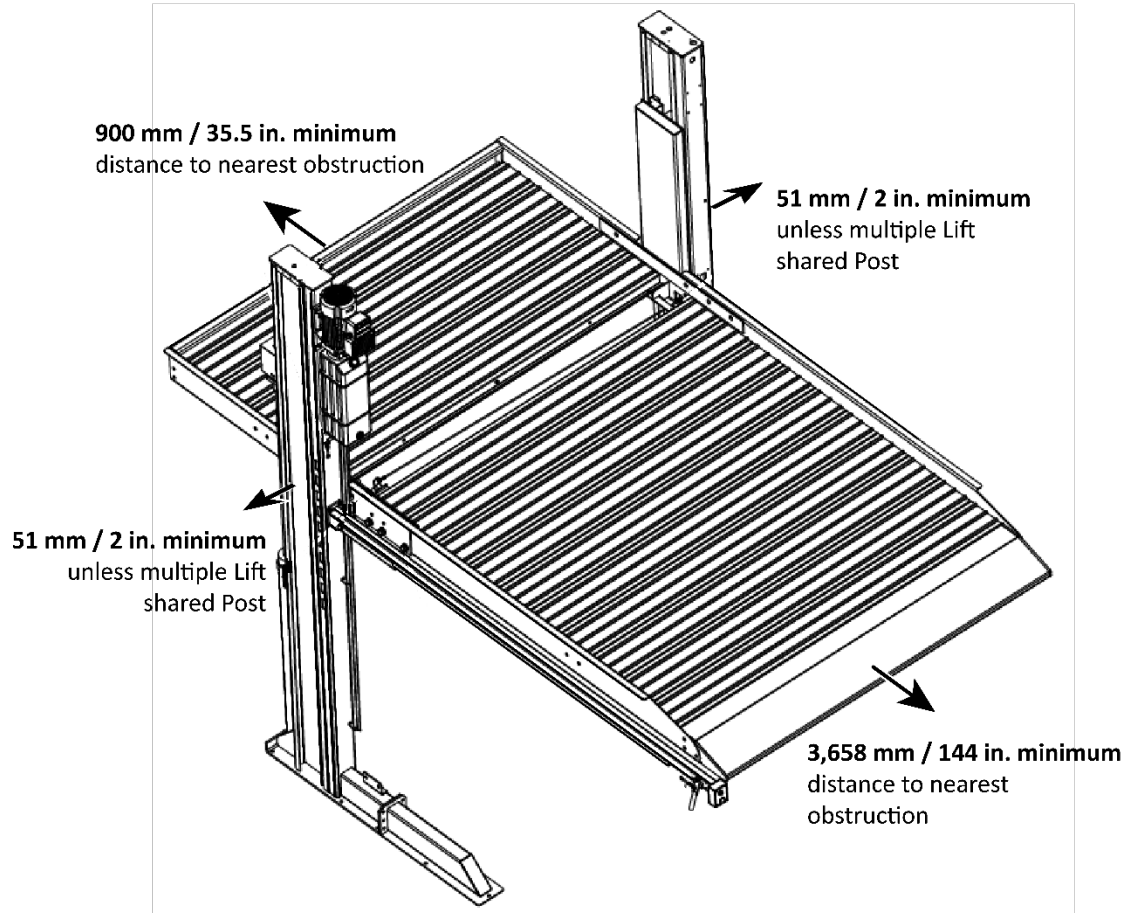

Unload and Unpack

Try to unload the components of the Lift near the location where you will be installing it.

Once the components are unloaded, they are your responsibility to move. As the Lift includes several heavy pieces, the closer you unload them to the installation location, the better off you are.

⚠ WARNING **Some Lift components are very heavy**; if handled incorrectly, they can damage materials like tile, sandstone, and brick. Try to handle the Lift components just twice: once when delivered and once when moved into position. You must have a Forklift or Shop Crane to move them into position. Use care when moving them around.

⚠ WARNING The Posts and Structural members are delivered with stabilizing structures on each end. Use caution when removing these stabilizing structures; the Posts and Beams could shift or even fall. If they fall on a person, they could cause serious injury.

Creating Chalk Line Guides

Creating Chalk Line Guides help ensure the Posts are installed correctly. Refer to the figure on the next page to create Chalk Line Guides for your Lift.

Your Lift has Two Posts:

- **Powerside Post:** Located on the Left side when viewed from the Approach. The Powerside Post holds, the Power Unit and Junction Box, Limit Switch, and the Control Panel, used to operate the Lift. **The Powerside Post is unique; it has drilled holes and weldments that hold the Power Unit, Limit Switch and Control Panel.** You must orient the Powerside Post so that the drilled holes in the base are oriented as shown in the figure on the previous page.
- **Offside (Shared) Post:** Located on the Right side of the Lift. When shared, this post will mount the Control Panel, Power Unit, Limit Switch and Junction Box for the second Lift.

To create the four Chalk Line Guides:

1. Create a Chalk Line to define the Front of the Lift; make the Front Chalk Line longer than the Total Width setting for your Lift.
2. Create the Powerside and Offside Post Chalk Lines at 90° angles to the Front Chalk Line and parallel to each other; make the Powerside Post and Offside (Shared) Post Chalk Lines longer than the Total Depth setting for your Lift model.

The Powerside and Offside Post Chalk Lines must be exactly **100.25 in. (2,547 mm)** distant from each other, **at both ends**. *Measure to verify that this is true.*

3. Create the Rear Chalk Line parallel to the Front Chalk Line; make the Rear Chalk Line longer than the Total Width setting for the Lift.

The Front and Rear Chalk Lines must be exactly **60.31 in. (1,532 mm)** distant from each other, **at both ends**. *Measure to verify that this is true.*

4. Before moving the posts into position, measure diagonally to verify the two diagonals are equal. Measuring diagonally ensures your layout is square. **Do not forget to check the diagonals.**

Refer to the figure below.

Chalk Lines PL-6000DC:

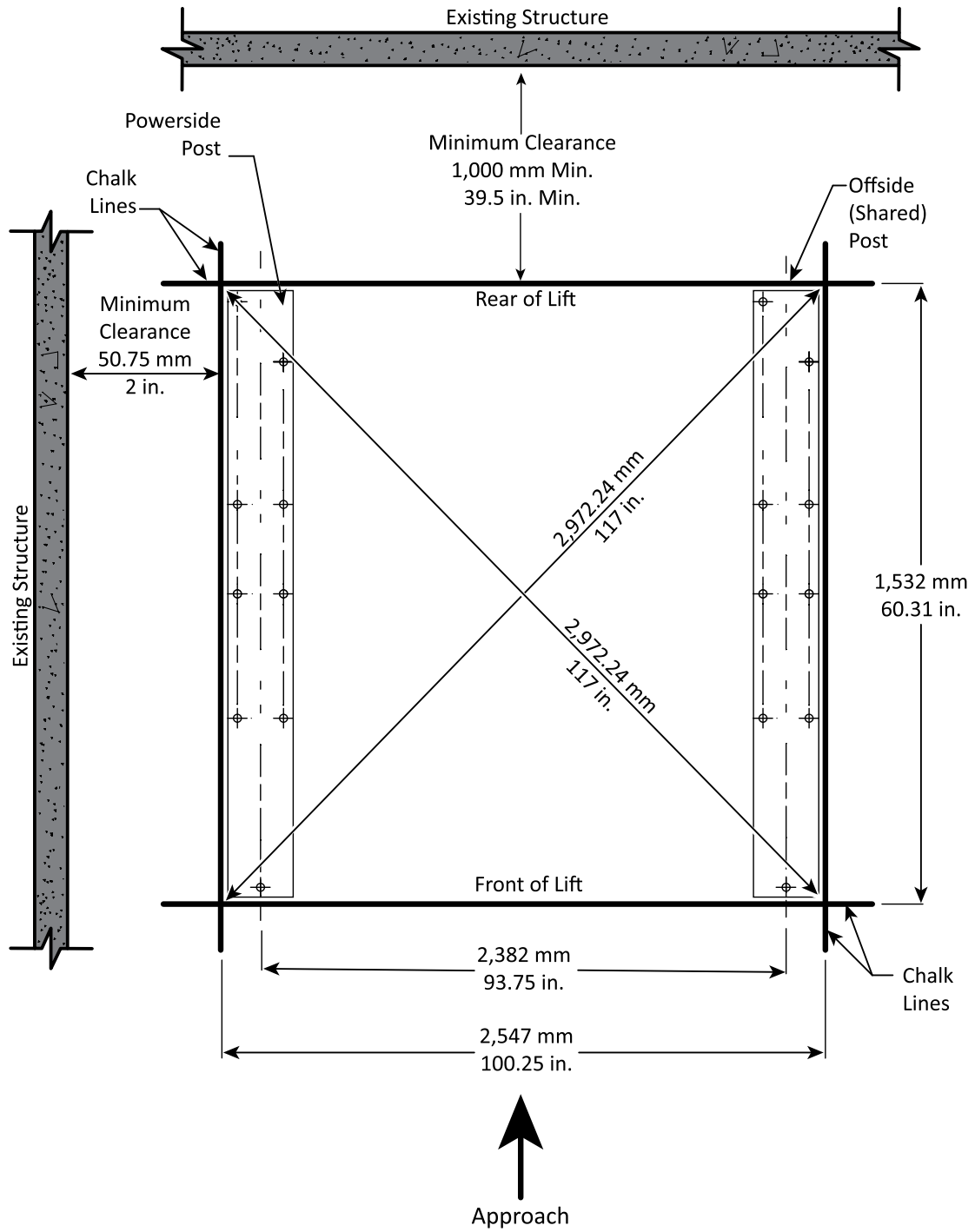

Drawing not to scale.

Chalk Lines PL-6000DCX:

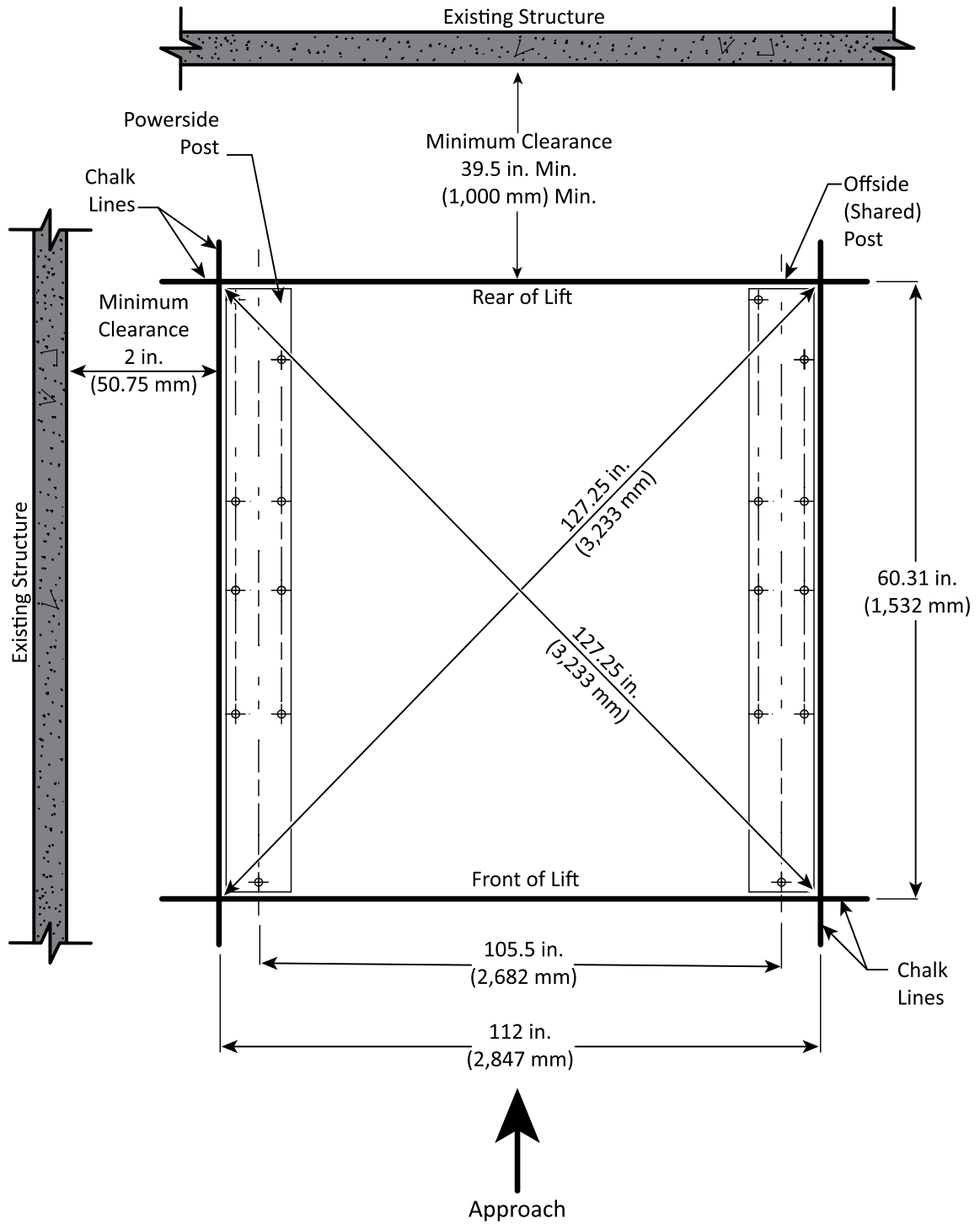

Move and Prepare the Lift Posts

This section moves the Lift Posts to the chalk lines and installs the Cover Plates, one end of the Balance Chain, the Limit Switch and feeds the Hydraulic Hose through the Powerside Post.

BendPak strongly recommends using a Forklift or Shop Crane to move the Posts. You need to have at least two people work together to stand up the Posts.

⚠ DANGER The Posts are heavy; be **very** careful when handling them. If they shift position or fall, they could cause serious injury. Only allow trained personnel to move the Posts and use appropriate lifting devices, such as a Forklift or Shop Crane.

To move the Posts into position:

1. For shipping purposes, two Lift Carriages are mounted on one post. With the help of an assistant, remove one carriage and install it onto the post that shipped without a carriage. Be careful to orient the Carriage on the Post correctly.

IMPORTANT The Carriage is a tight fit. Apply a small amount of Lithium Grease to the inside of the Lift Post to ease the Carriage motion.

2. Using a Forklift or Shop Crane, move the Posts, one at a time, near to the Chalk Line Guides you created. The Powerside Post and the Offside Posts are different. Look for the long side of the Lift Carriage and position that side toward the Approach of the Lift. Do **not** stand the Posts up yet.
3. Attach the Front Supports to both Posts using (6) Six M12 x 45 Hex Head Bolts with Ø12 mm Flat Washer, Lock Washer, and Hex Nut on each Front Support.

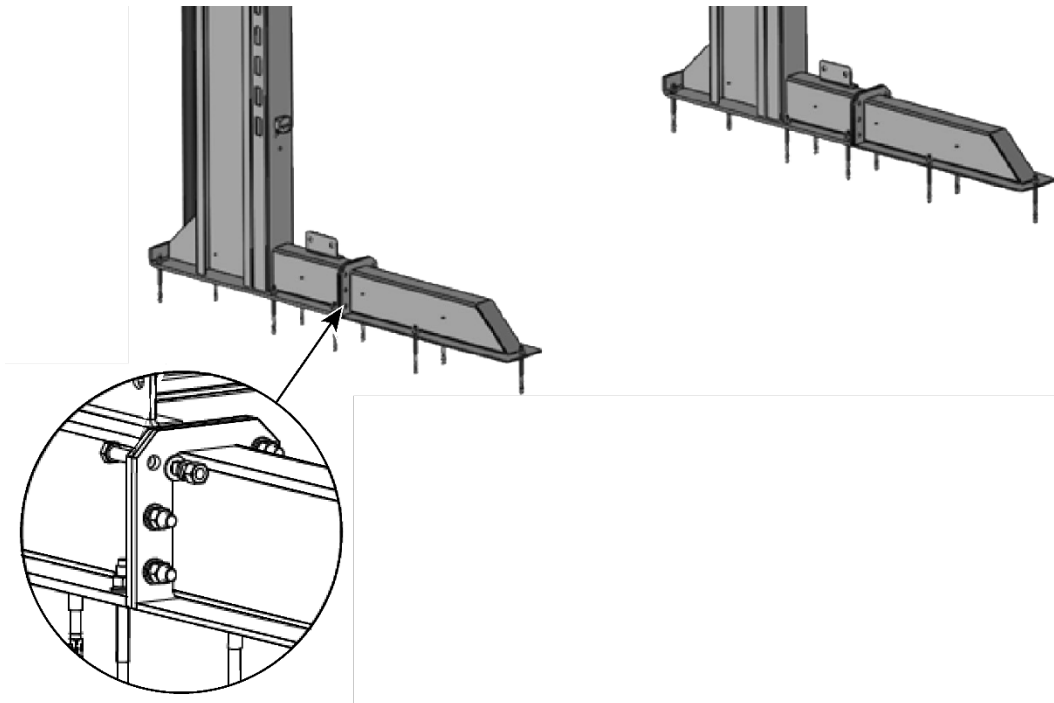

4. Install the Top Cover Plate on each Post using four M10 x 30 Hex Bolts, Lock Washer, Flat Washer, and Nut. Refer to figure below.

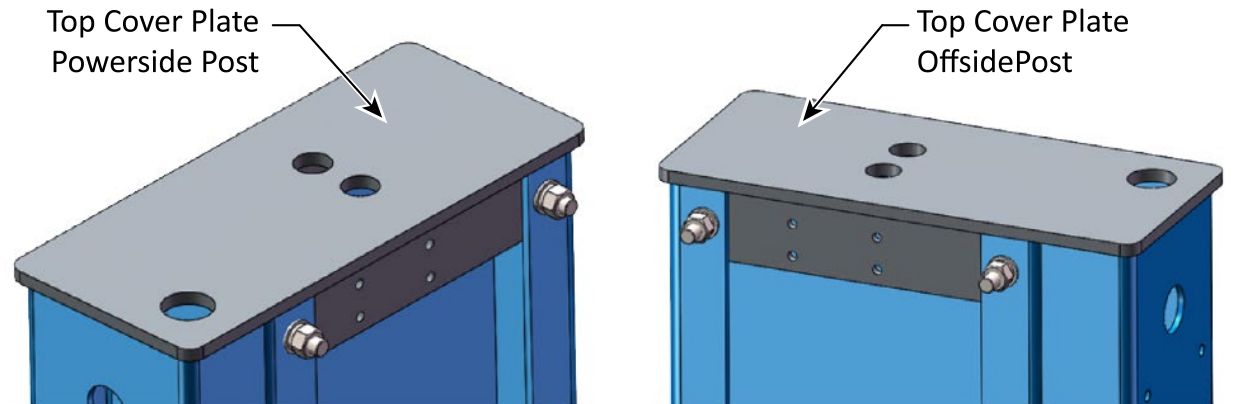

Drawing not to scale.

5. Insert the Threaded Rod with chain mount into the cover of the Offside Post and attach with double M18 Nuts and $\text{\O}18$ mm Flat Washer, then attach one end of the Balance Chain to the Chain Mount using two split pins 2 x 20. See figure below. Allow the Balance Chain to hang from its mount for the moment.

Note: There are two Chains provided with the Lift, a Balance Chain, and a Lift Chain. The Balance Chain is the longer of the two.

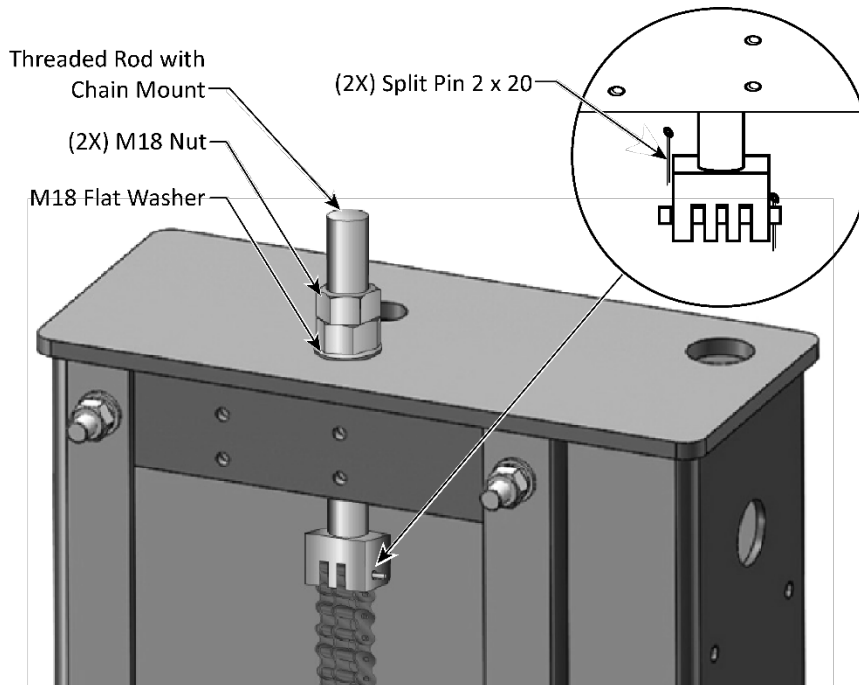

Drawing not to scale.



CAUTION

Keep Chains clean and away from dirt during installation.

6. Mount the Limit Switch to the top of the Powerside Post using two M4 x 20 and two M4 x 40 machine screws. See figure below and page 54.

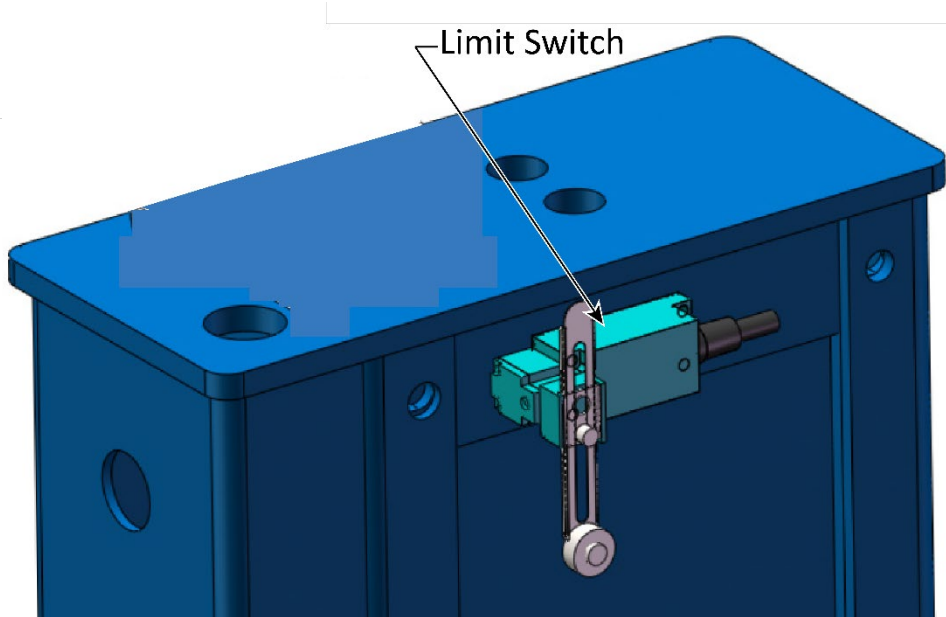

Drawing not to scale.

7. Loosen the Phillips screw and extend the Limit Switch arm to its maximum distance toward the Lift Platform. Refer to the figure below.

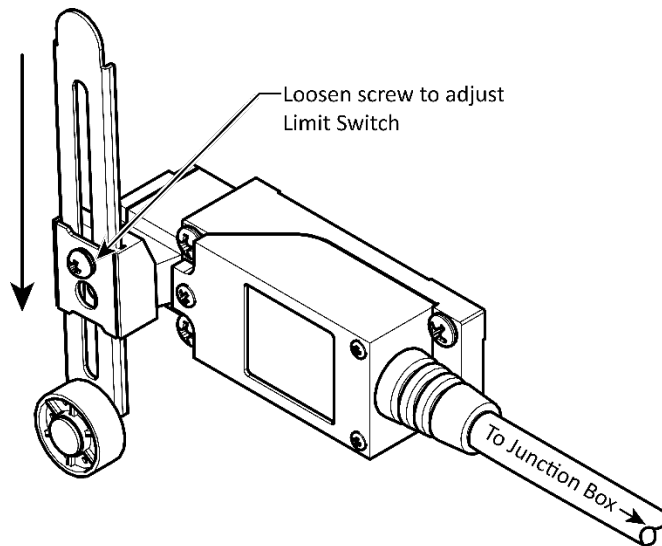

8. Feed the Hydraulic Hose through the inside of the Powerside Post from top to bottom. Use tape or wire to temporarily hold the Hose in place while standing-up the Posts. See figures below.

⚠ WARNING Do not damage Hydraulic Hoses by bending into a tight radius. (Hydraulic Hose bending radius is to be more than 9 times the outer diameter of Hose.)

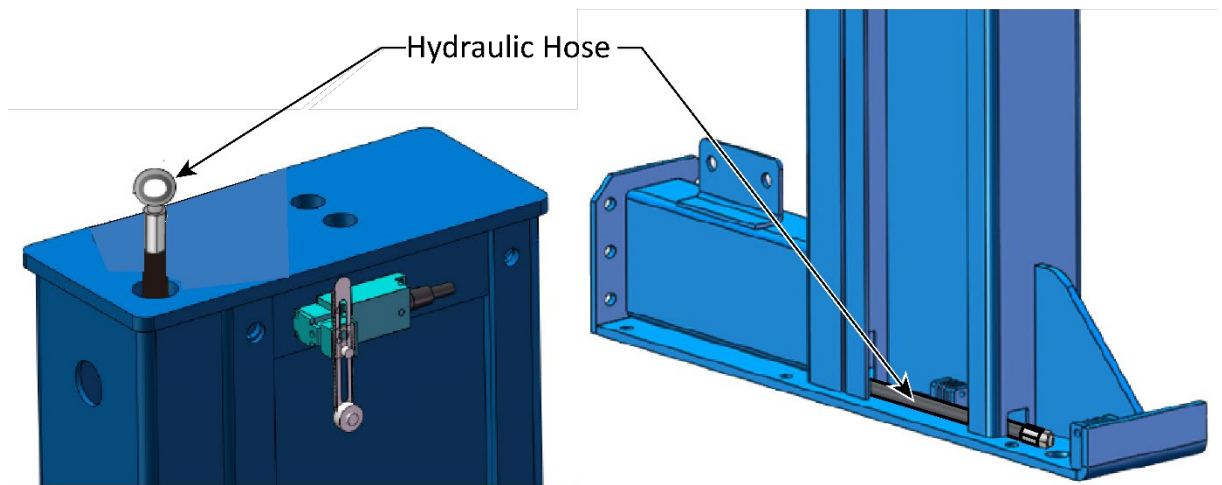

Drawing not to scale.

- Slide the Lift Carriage up on both Posts until the Safety lock engages at about 24" / 600 mm.

⚠ WARNING The Lift Carriages are **heavy**, use assistance to slide them along the post.

Anchoring the Powerside Post

The Powerside Post **must** be anchored to prevent movement.

⚠ WARNING You **must** always wear OSHA-approved (publication 3151) appropriate protective equipment during installation: leather gloves, steel-toed work boots, eye protection, back belts, and hearing protection are **mandatory**.

⚠ WARNING The Lift Posts are heavy and the weight is not evenly distributed. Use proper tools, Forklift or Shop Crane, and assistants to move the posts into position.

- Stand-up the **Powerside Post** and move it to the location marked by the chalk lines created earlier.

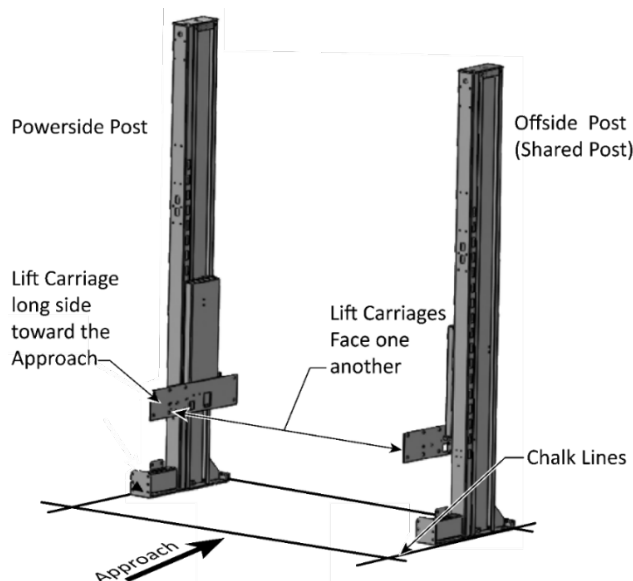

-
- Using the **Powerside Post Base** as a pattern, use a Hammer Drill to create Ø12 mm holes 130 mm deep in the concrete. See figure below.

Drilling accurate holes for Expansion Anchors in Concrete is both critical and challenging. If the Holes for the Anchors are too big, the Anchor will not expand correctly and ultimately will not embed in the hole with enough force to make a good anchor. If the Holes are too small, the Anchor will be damaged as it is driven in and will not expand to embed correctly. If the hole is drilled at an angle, the bolt or Nut will not engage the Lifts' Base Plate with maximum holding power.

Use the right tools. A powerful Hammer Drill with new Drill Bits intended for Rotary Hammer and Masonry use. Ensure the Drill Flutes are at least as long as the hole you are drilling to remove the material from the hole as you drill.

Check the size of the Drill Bit before you begin! The drill may be dull and or undersized from excessive use. An undersized hole is just as bad as an oversized hole. Undersized holes deform the anchor and do not allow it to embed correctly.

Drill a Pilot Hole. The final hole size is to be Ø12 mm, drill an 8 to 9 mm pilot hole first. Pilot holes allow straighter, cleaner drilling by removing the material directly in the center of the final drill. This reduces the amount of force required to keep the final drill straight and perpendicular to the floor.

Find the Rebar! Steel Reinforced Concrete is ideal for strong construction, but terrible for drill bits. Rebar can and will ruin a Masonry Drill Bit, as well as push the drill off center and ruin the Anchor Hole by making the hole out of round or too big. Hire a contractor to find the rebar in the location you wish to install your Lift. Many contractors use ground penetrating radar to accurately locate rebar.

If you hit Rebar embedded in the Concrete and have not ruined the Anchor Hole by making it too big or out of round, switch to a rebar cutting drill bit. Slow the drill speed to avoid overheating the drill bit. Continue drilling until you are past the Rebar.

Use a Depth Gauge or place tape on the Drill Bit to indicate the final hole depth.

Don't rush. Pull the drill out of the hole at regular intervals to clear the material out of the hole as you drill.

If you see sparks, stop, you have hit rebar. Switch to a Rebar-Cutting Drill Bit and then complete the drilling operation.

Vacuum, brush and blow out the hole frequently as you drill to clean debris out the hole.

When the drill has reached its final depth, clean the hole using a brush, vacuum and/or compressed air.

- Insert the Anchors. Place the Anchor in the opening with a Flat washer and Hex Nut attached. You may have to tap the Anchors in with a Mallet or Hammer. Do **not** damage the Anchor threads. Refer to figures below.
- Do **not** tighten the Anchor Nuts at this point. Leaving the Nuts finger tight allows for adjustment and shimming later in the installation.

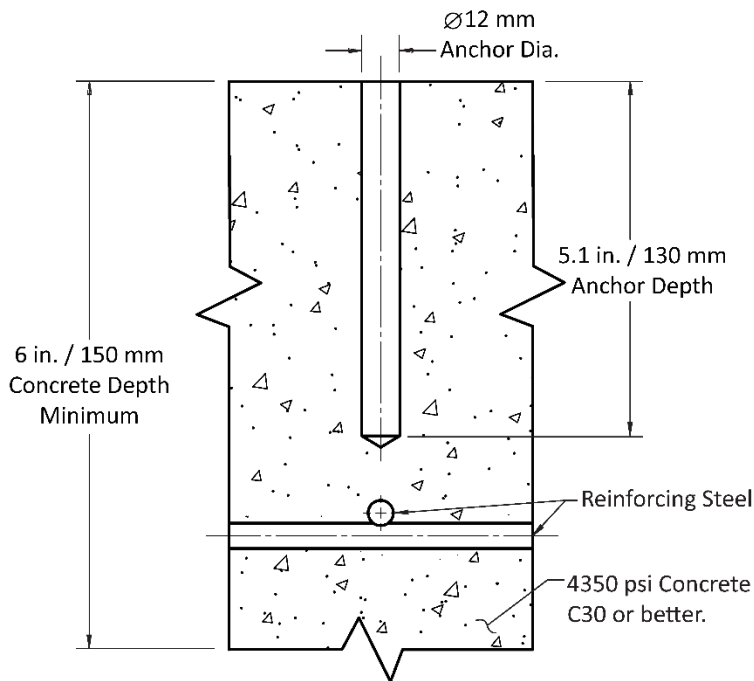
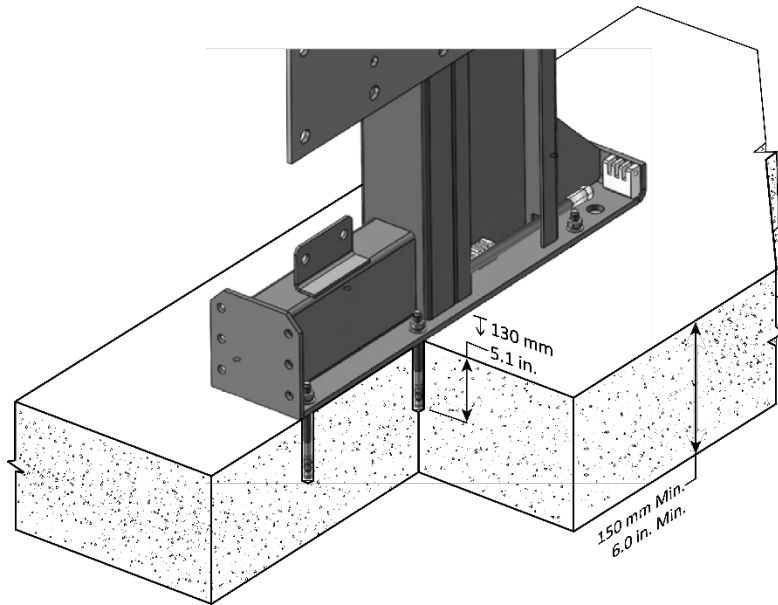

Drawing not to scale.

5. Do **not** stand up the Offside Post yet.

Attach the Side Beams, Back Plate and Connection Rods

This section addresses attaching the Side Beams, Connection Rods, and Back Plate. These components are heavy.

⚠ WARNING You **must** always wear OSHA-approved (publication 3151) appropriate protective equipment during installation: leather gloves, steel-toed work boots, eye protection, back belts, and hearing protection are **mandatory**.

⚠ WARNING The components are heavy and their weight is not evenly distributed. Use proper tools, Forklift or Shop Crane, and assistants to move the posts into position.

To attach the Side Beams, Back Plate, and Connection Rods:

1. Attach the Left Side Beam onto the Powerside Post Lift Carriage. Use four sets of M20 x 110 Hex Head Bolts, Ø20 mm Flat Washer, Ø20 mm Lock Washer and M20 Hex Nut. Verify the Hex Bolt heads, and Flat Washers are on the inside of the Lift and the Nuts, Lock Washers on the outside of the Beam facing out from the Lift. Refer to the figure on the next page.
2. Attach the Right-Side Beam onto the Offside Post Lift Carriage. Use the same Fasteners as referenced in step 1 above. Verify the Hex Bolt heads, and Flat Washers are on the inside of the Lift and the Nuts, Lock Washers on the outside of the Beam facing out from the Lift. **Do not install the Four M20 x 55 Hex Head bolts at this time.** Refer to the figure on the next page.

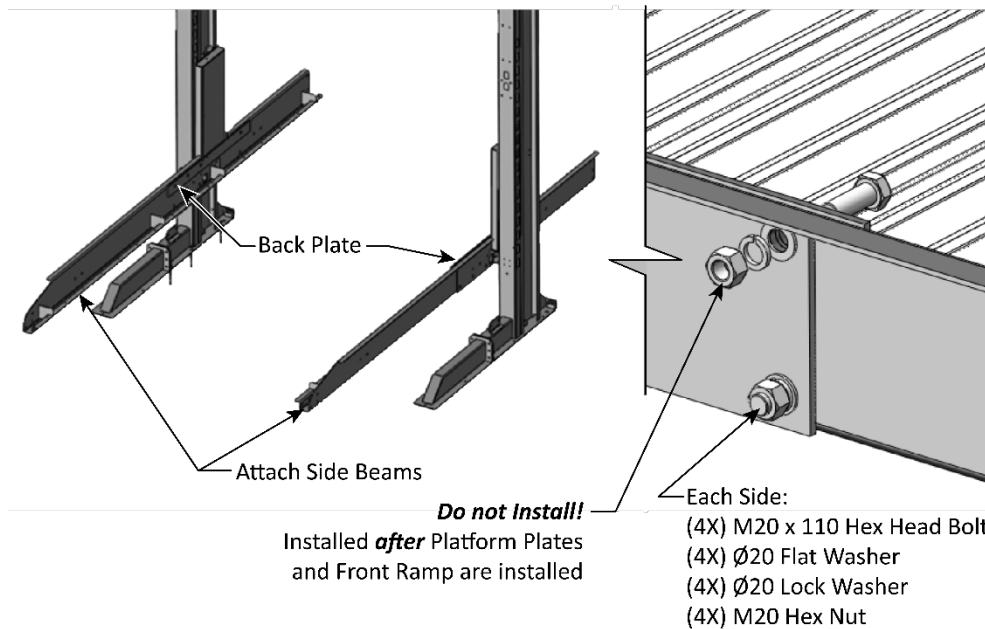

3. Stand-up the **Offside Post** and move it to the chalk lines previously created. **Do not drill holes for the Anchors.**

Note: If multiple units are being installed, this Offside Post will be shared and act as the Primary post for the next Lift

4. Install the Back Plate with the Groove facing the Approach Side of the Lift. Attach with two M14 x 40 mm Hex Head Bolt, Ø14 Flat Washer, Ø14 Lock Washer and M14 Hex Nut each side. Make all fasteners finger tight, **do not tighten.** Refer to the figure below.

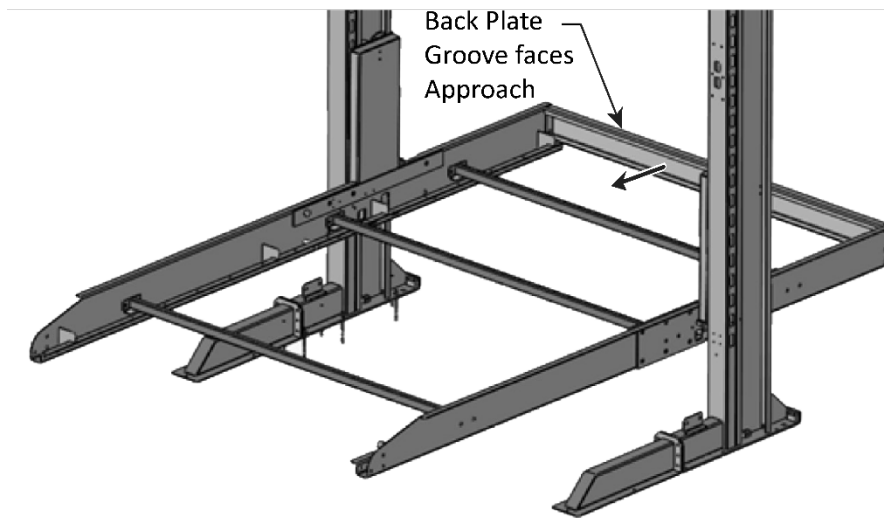

Drawing not to Scale.

5. Install three Connection Rods between the Two Side Beams. Each Beam will require 2 sets M14 x 40 mm Hex Head Bolts, Ø14 mm Flat Washer, Ø14 mm Lock Washer and M14 Hex Nuts. Refer to the figure below. Make finger tight. **Do not tighten** the fasteners yet.

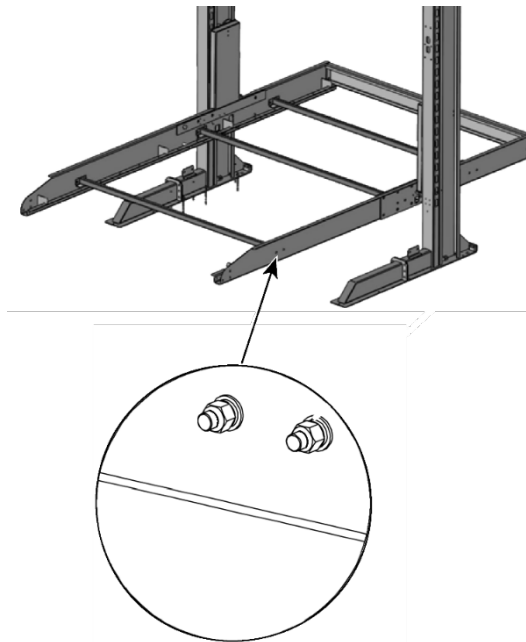

Route and Attach the Balance Chain

The Balance Chain levels the Lift Platform as it is raised and lowered. The Chain is connected between the top of the Offside Post and the bottom of the Powerside Post. The chain is routed in a rough Z-shape. Reference the figure below.

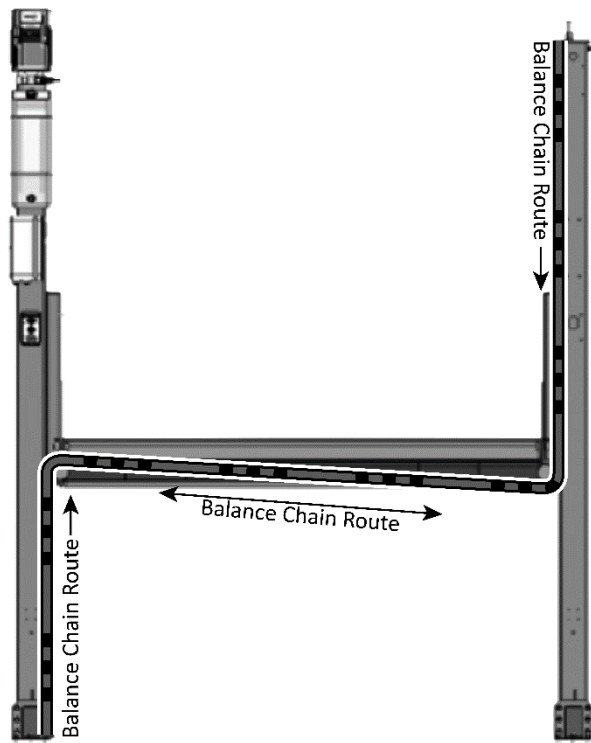

To Route and Attach the Balance Chain:

1. On the Offside Post the Balance Chain routes beneath a Chain Roller and heads left through the small opening in the Lift Carriage and Side Beam. Refer to the figure below.

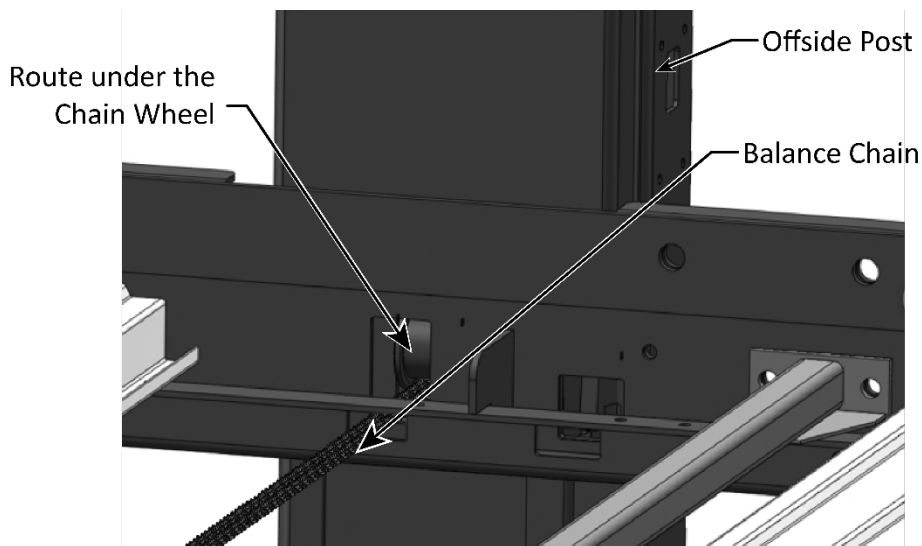

Drawing not to scale

2. On the Powerside Post, route the Balance Chain above the small opening in the Side Beam then through the Beam and over the Chain Wheel to the bottom of the Powerside Post. Refer to the figure below.

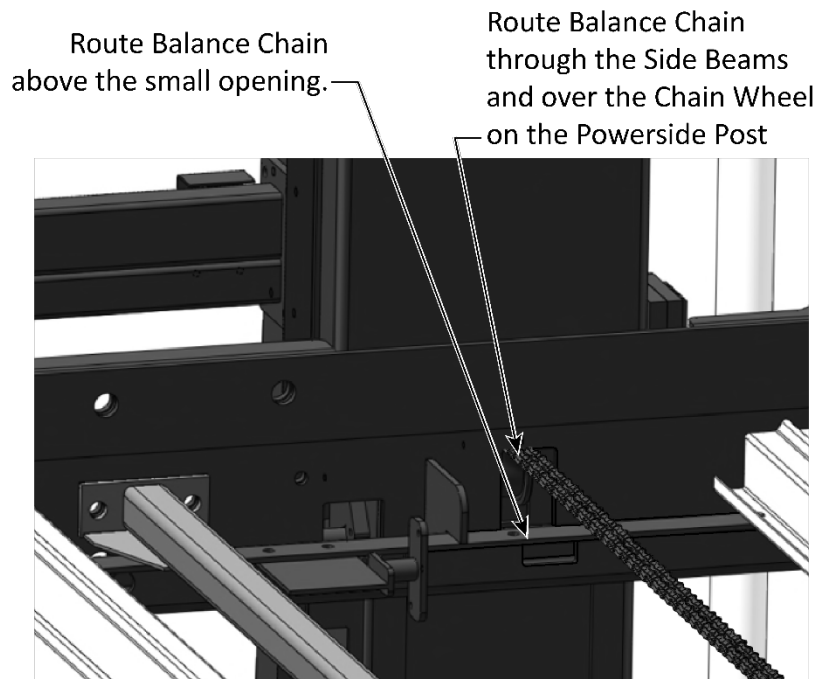

Drawing not to scale.

3. Attach the Balance Chain to the bottom of the Powerside Post using two 2 mm x 20 Split Pins. Refer to the figure below.

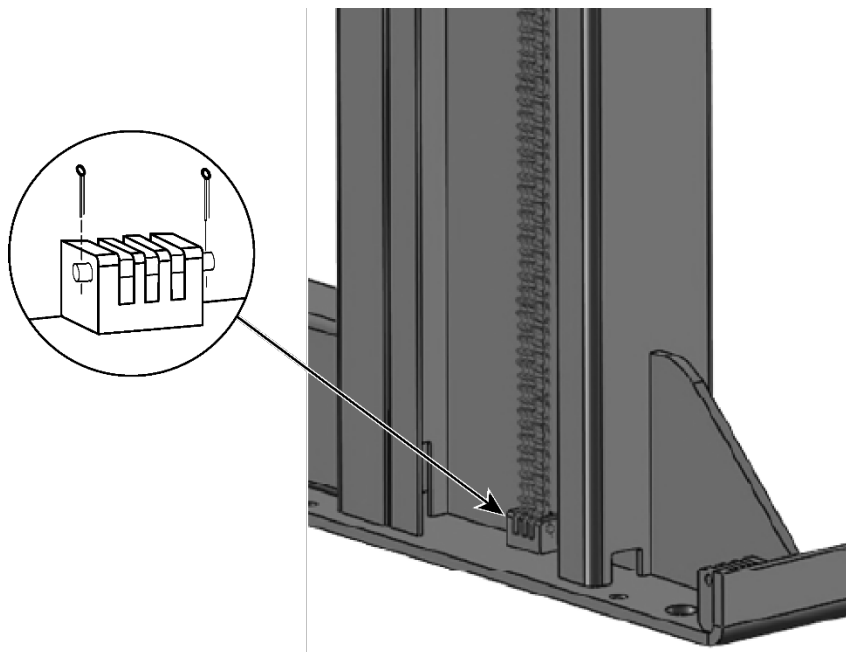

Drawing not to scale.

Connecting the Safety Lock Release - Lift Carriages

Safety Locks are triangular shaped spring-loaded plates mounted on the Lift Platform that snap into slots in both Posts preventing downward motion. The Safety Lock Release prevents the Lock from engaging the slots in the Posts thus allowing the Lift platform to lower.

To install the Safety Lock Release:

1. Mount the Unlocking Pin Seat on the Powerside Side Beam using the existing holes with two M10 x 25 and two M10 Hex Nuts with Flange. Refer to the figure below.

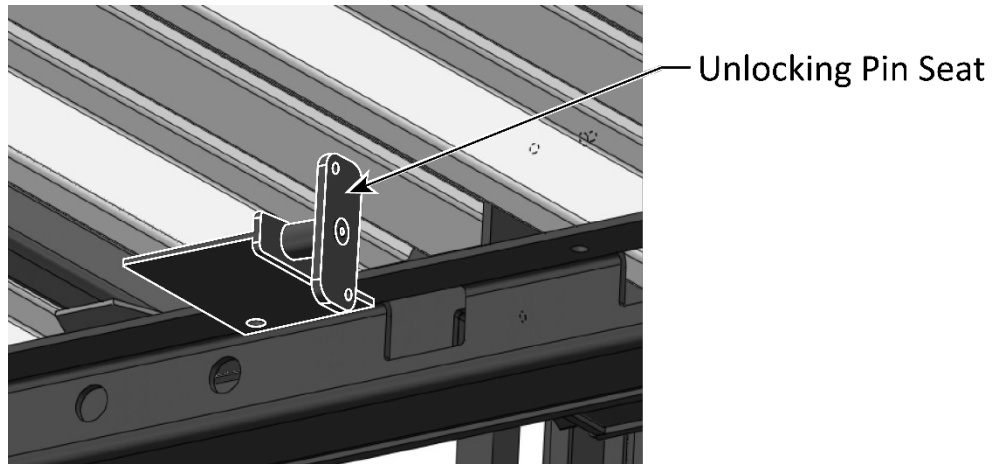

Drawing not to scale.

2. The Unlocking Rod, Adjustable Joints and Articulated Bearings are installed beneath the Platform and connect the Triangular Shaped Locks on the Powerside and Offside beams. Refer to the figure below.

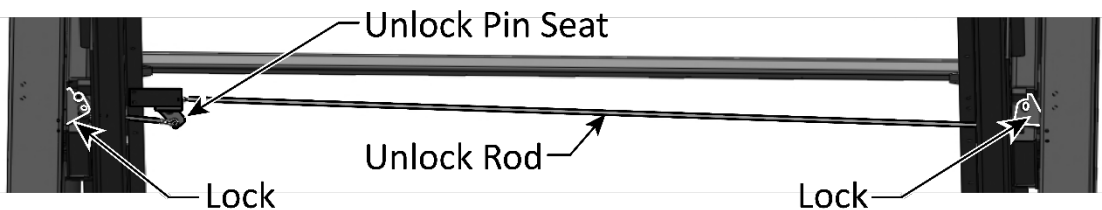

Drawing not to scale.

3. Connect the Adjustable Joint and Lock on the Powerside Lift Carriage to the Unlocking Pin Seat and the Lock, using two M6 x 35 Hex Head Bolts and M6 Hex Nuts. Refer to figures and detail below.

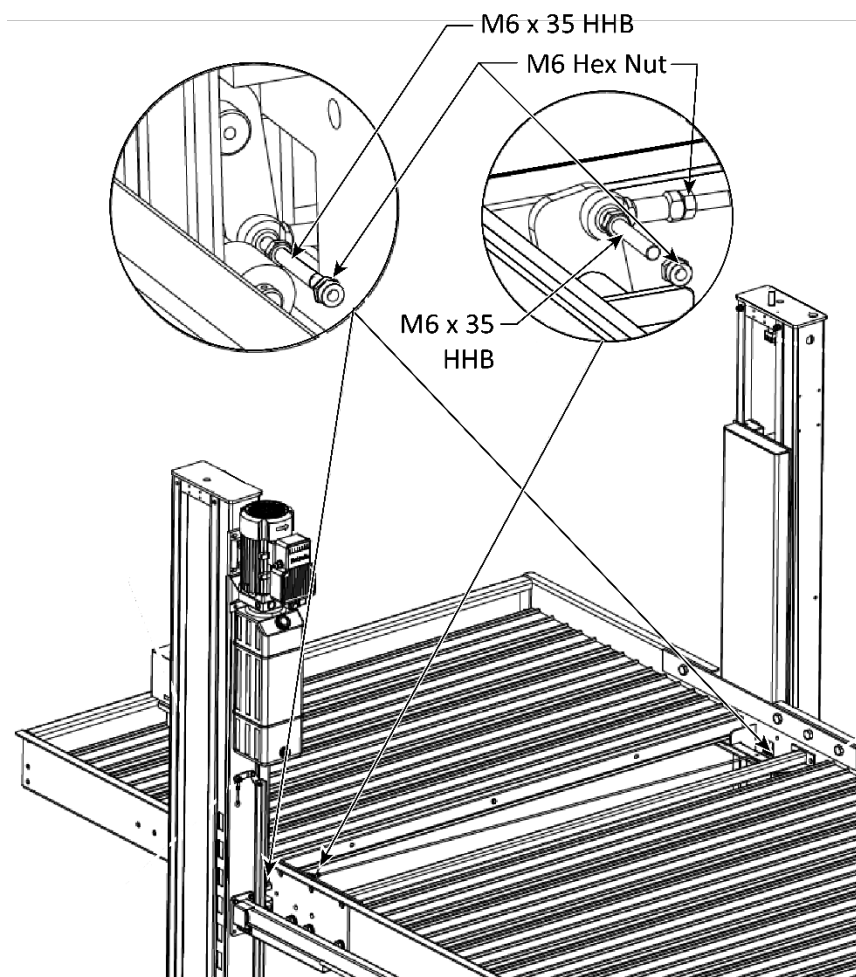
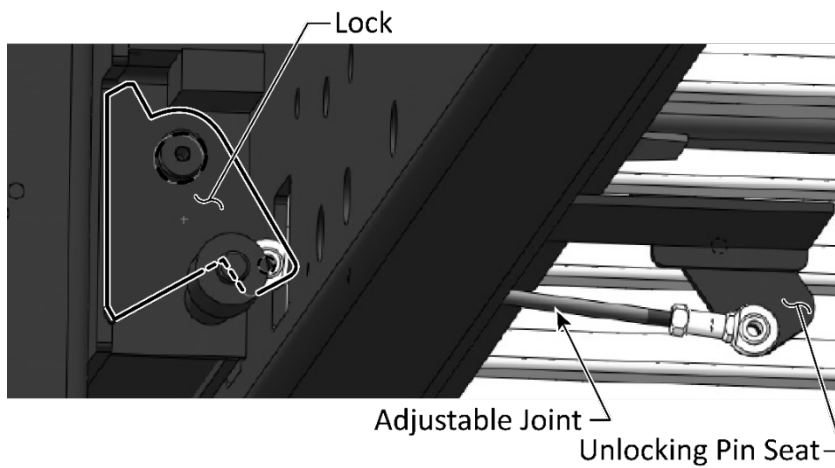

Drawing not to scale.

4. Connect the Unlock Rod to the Unlock Pin Seat Using the M6 x 35 and M6 Hex Nuts. Refer to the figure below.

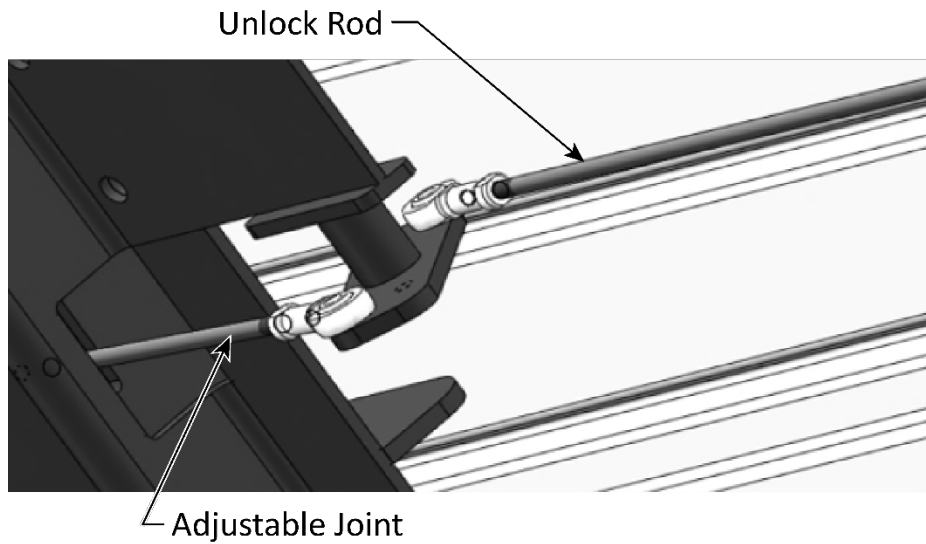

Drawing not to scale.

5. Connect the Unlock Rod to the Lock on the Offside Lift Carriage using a M6 x 35 Hex Head Bolt and M6 Hex Nut. Refer to the figure below.

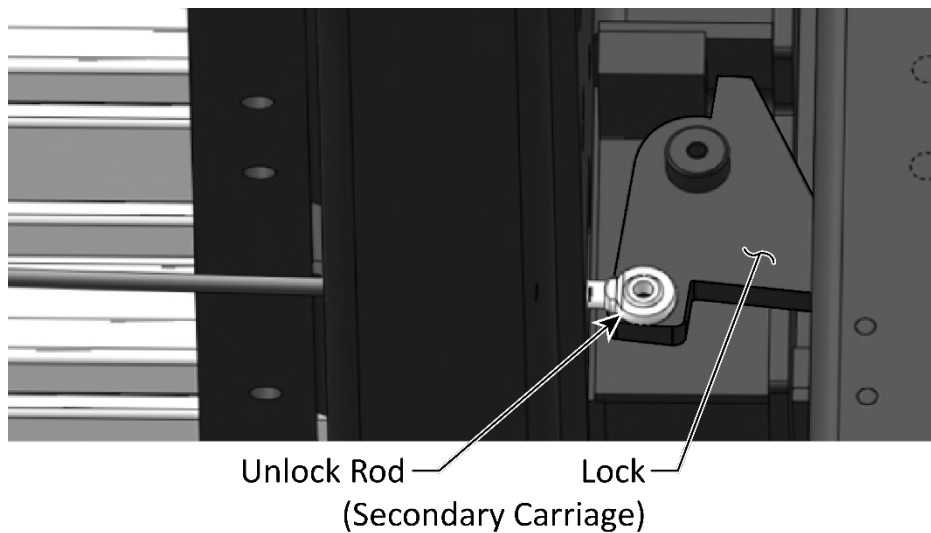

Drawing not to scale.

Installing the Lift Cylinder and Lift Chain

The Lift Cylinder receives hydraulic fluid from the Power Unit. As the Cylinder Rod extends, it drives the Lift Chain that is attached on one end to the Lift Carriage and on the other end to the Powerside Lift Post.

To attach the Lift Cylinder and Lift Chain:

1. Attach one end of the Lifting Chain to the Mounting at the Base of the Powerside Post. Refer to the figure below. Lock the Pin through the Chain and Mount with two 2 mm x 20 mm Split Pins, one on each side.

Install the Lift Cylinder on the Powerside Post in the holes provided at the bottom of the Post.

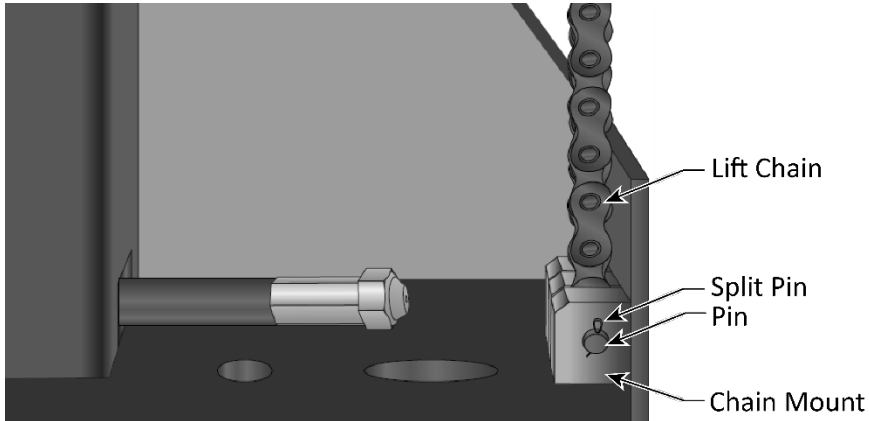

2. Attach the Cylinder to the Powerside Post using the Cylinder Bracket and Two M10 Socket Head Cap Screws. Refer to the figure below.

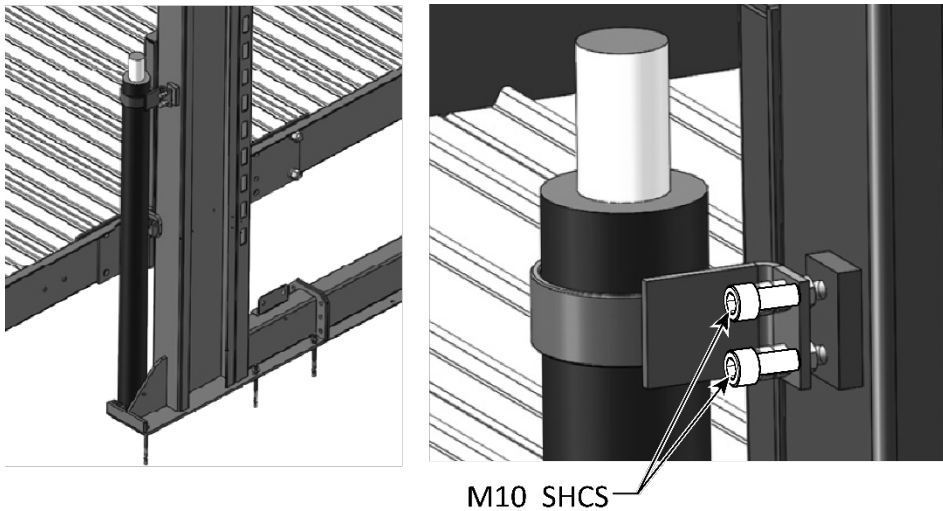

Drawing not to scale.

3. Place the Cylinder Head with Chain Wheel on the Cylinder Rod. Refer to the figure below.

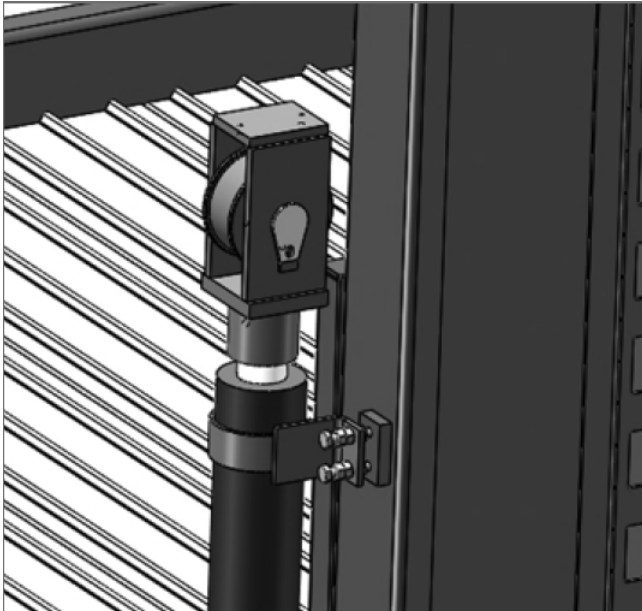

Drawing not to scale.

4. Feed the Lift Chain into the Cylinder Head over the Chain Wheel and then attach to the Chain Mount on the Powerside Lift Carriage using two 2 mm x 20 Split Pins. Refer to the figure below.

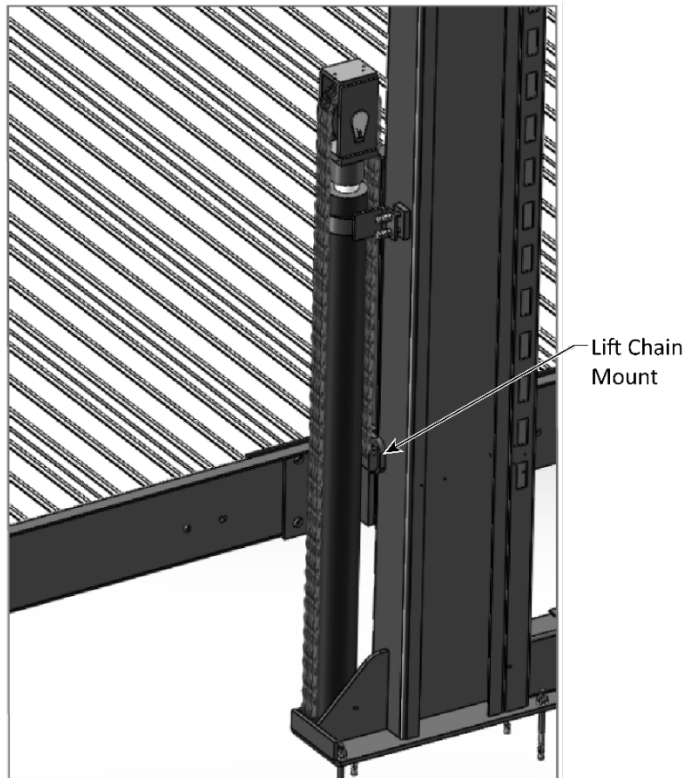

Drawing not to scale.

-
5. Connect the Hydraulic Hose to the bottom of the Lift Cylinder and tighten. Refer to the figure below.

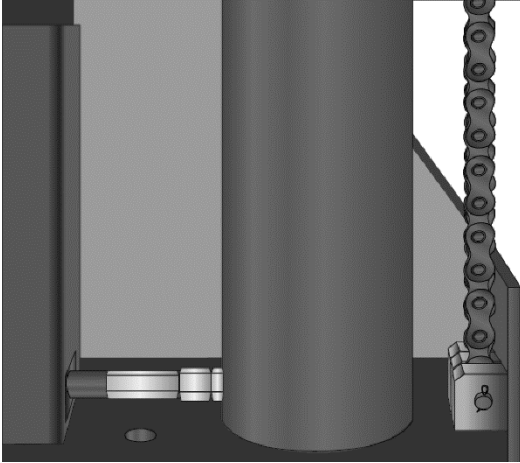

6. Install the Cylinder Head Cover.

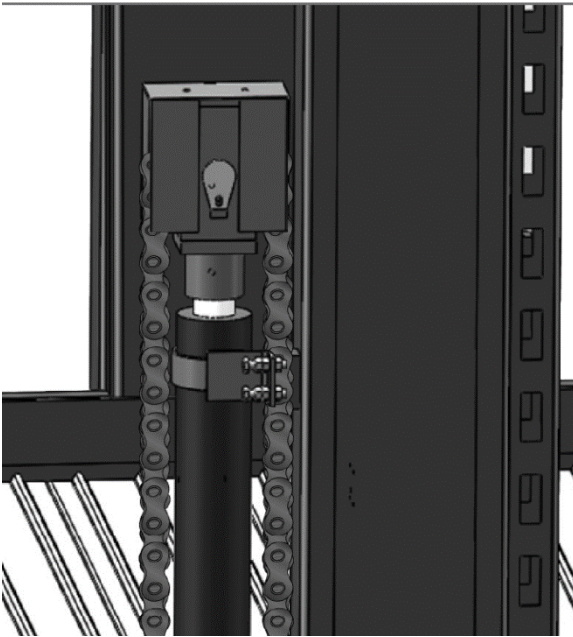



IMPORTANT! PLEASE READ NOW



Hydraulic Fluid Contamination poses a serious issue for your Lift; contaminants such as water, dirt, or other debris can get into the Hydraulic Hoses and Fittings on the Lift, making your new Lift inoperable and unusable.

Your Lift is shipped with clean components; however, BendPak strongly recommends that you take secondary precautions and clean all Hydraulic Hoses and Fittings prior to making connections. It is better and less costly to take these extra steps now so that you do not need to take your Lift out of service later to fix issues that could have been prevented at the time of installation.

There are several ways to clean Hydraulic Hoses and Fittings:











- **Compressed Air.** Use an air compressor to blow out contaminants from each Hydraulic Hose and Fitting prior to installation. Clean, dry air is preferred. Wear ANSI-approved eye protection (safety glasses, goggles, or face shield) when using compressed air for cleaning. Never point an air hose nozzle at any part of your body or any other person.
- **Fluid Flushing.** If the Hydraulic Fluid is clean and compatible with the system fluid, you can flush Hoses and Fittings to create turbulent flow and remove particulates. Always ensure that the fluid itself is contaminant-free.

Some additional steps that will help keep the Hydraulic Fluid clean:

- **Remove old thread seal tape.** Some ports on the Hydraulic Cylinders are shipped with temporary plugs secured with thread seal tape, so make sure to thoroughly remove any leftover thread seal tape that may inadvertently enter the Hydraulic System.
- **Use a liquid thread sealant only.** Liquid thread sealant (Loctite™ 5452 or similar) is recommended. Do not use thread seal tape on any fitting. Liquid thread sealant is recommended for NPT connections, fine for JIC connections, but *not* necessary for O-ring (ORB) connections.
- **Always use clean equipment.** If you use a dirty bucket or funnel to transfer the Hydraulic Fluid into the Hydraulic Fluid Reservoir, the contaminants will likely be introduced into the Fluid. When using cleaning rags, use a lint-free rag.
- **Proper storage.** Keep the Hydraulic Fluid sealed in its container until ready for use; store the Fluid in a clean, dry, and cool area.
- **Cover the Hoses and Fittings.** Before installation, do not leave the ends of the Fittings exposed; the same applies for the Hydraulic Hoses. As a rule, keep the Hydraulic Hoses and Fittings capped and in a clean area until ready for use.
- **Filter the new Hydraulic Fluid.** Just because it is new does not necessarily mean it is *clean*. Use an offline filtration cart or kidney loop system to make sure the Hydraulic Fluid is clean before being transferred into the Hydraulic Fluid Reservoir (even using a heavy-duty nylon mesh screen is better than trusting what is left at the bottom of the barrel).
- **Avoid mixing different types of Hydraulic Fluid.** If Hydraulic Fluid needs to be replaced, make sure to flush the Hydraulic System of the old Hydraulic Fluid before you add the replacement Fluid; do not mix the two together.

Hydraulic System Warnings

Before applying power to the Hydraulic System note the following Warnings:

-  **WARNING** Failure to observe these warnings can result in serious personal injury including, in rare cases, death.
-  **WARNING** The Hydraulic hoses and connections **must** be inspected before any attempt to raise a Vehicle is made.
-  **WARNING** Verify all Hydraulic Hose connections and fittings, including unused auxiliary port plugs on the Power Unit, the Flow Divider, the Cylinders and anywhere else in the Hydraulic System are tightened.
-  **WARNING** The Power Unit is a Hydraulic Pump capable of developing pressures in excess of 5,000 psi (345 BAR). A pressure relief valve is used to set the pressure at the desired level. Tampering with, adjusting, modifying, or removing the relief valve is extremely dangerous and is not recommended. Only trained Hydraulics technicians should make adjustments to the relief valve, using calibrated hydraulic pressure gauges to assure the proper pressure setting is achieved.
-  **WARNING** Changes to the output pressure may render the power unit incompatible with pressure limitations of other components in the hydraulic circuit. This may cause catastrophic failure of those components, and could result in property damage, serious personal injury, or death.
-  **WARNING** The Hydraulic System can contain high pressure which, if suddenly released, can cause serious injury or death.
-  **WARNING** Do **not** attempt to connect or disconnect Hydraulic Hoses while the equipment is loaded or while a Vehicle is on the Lift or the Hydraulic System is under pressure.
-  **WARNING** Keep bare hands away from Hydraulic Fluid; always wear gloves when handling Hydraulic Fluid, Cylinders or Hydraulic Hoses.
-  **WARNING** When handling Hydraulic Fluid, always observe the safety instructions from the manufacturer.
-  **WARNING** **Always** promptly clean any Hydraulic Fluid spills. If a leak is the source of the spill, lockout the Lift to prevent use until the Hydraulic System is repaired.

About Thread Sealants

Use Thread Sealant on NPT threads only. Liquid Thread Sealant lubricates and fills the gaps between the **NPT Fitting** threads and leaves no residue that could contaminate the Hydraulic Fluid.

Other types of Thread Sealants (like Teflon Tape) can shred during installation or removal and eventually enter the Hydraulic System.

Liquid Thread Sealant is largely designed for use with NPT connectors.

Apply the thread sealant when the ambient temperature is between +46.5°F to +70°F (+8°C to 21°C)



To apply Thread Sealant:

1. Make sure the NPT Fittings and connectors you are going to use are clean and dry.
If you are adding Thread Sealant to a Fitting or connector that has already been used with a different sealant, use a wire brush to thoroughly remove the old sealant before adding more.
2. Leave the first 1-2 threads dry, without sealant. Apply a small amount of Thread Sealant (Loctite 5452 or similar) to the next four to five threads of the Fitting.

⚠ WARNING Always wear the proper protective equipment when handling Thread Sealant.

You only need a small amount because the sealant spreads to the other threads as it is tightened into place.

If you use too much, the excess liquid will be pushed out as the Fitting is tightened; use a rag to remove the excess.

3. Hand tighten the Fitting into its connector, then turn with the appropriate wrench two to three turns more; do **not** over tighten the Fitting!

Allow the **24-hour** manufacturer-recommended curing time before pressurizing the system.

Install the Power Unit

This section describes the mounting of the Hydraulic Power Unit. An Electrician is **not** required to mount the Power Unit to the Powerside Post.

⚠ DANGER Risk of explosion: This equipment has internal arcing or parts that may spark and should not be exposed to flammable vapors. Never expose the Motor to rain or other damp environments.

⚠ WARNING Running the Power Unit without Hydraulic Fluid will damage it and this damage is not covered under warranty.

⚠ WARNING Damage to the Power unit due to water, detergents, acid, and other liquids is **not** covered under warranty.

⚠ WARNING The Power Unit is very heavy. BendPak strongly recommends you mount the Power unit with the reservoir empty. One person should support the Power unit in place while another bolts the unit into place.

To install the Power Unit:

1. Retrieve the Power Unit Mount. Two possible mounts may be shipped with the Lift. One connects to the power unit block, the other connects at the motor mount. Retrieve the Bolts and Flat Washers to mount the Power Unit and mount to the Lift Post as shown.

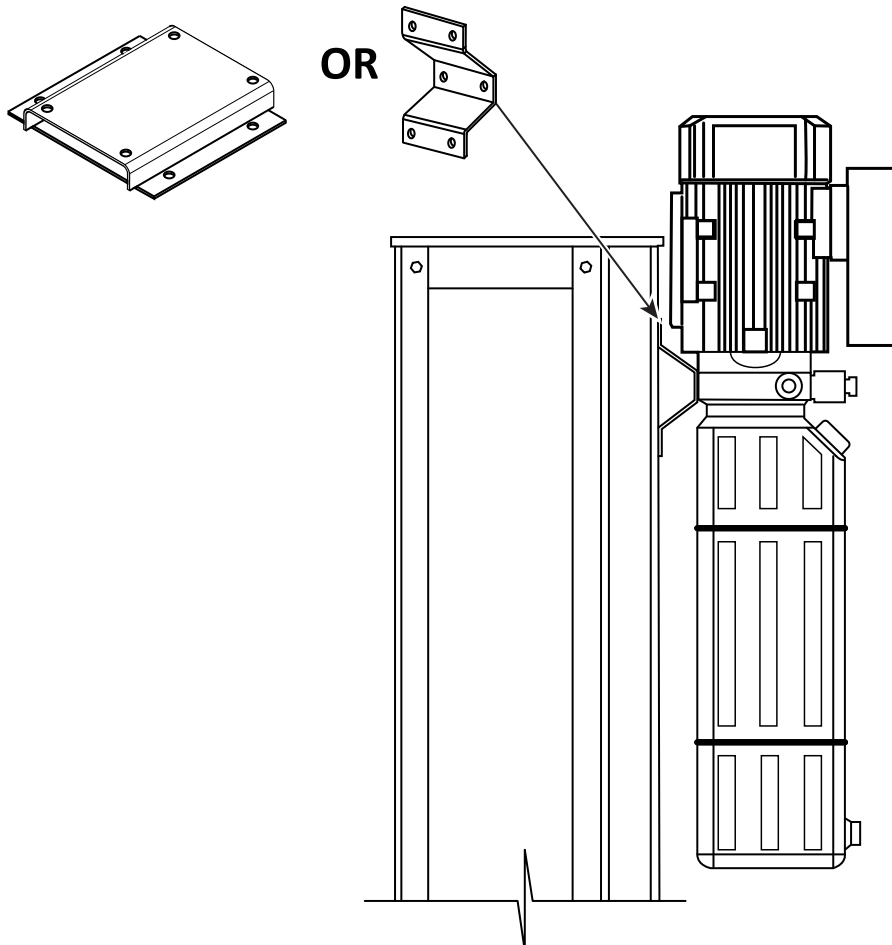

- Fill the Power Unit Hydraulic Reservoir with approximately 2.6 gal. / 10 L Hydraulic Fluid through a clean funnel with a 60-micron filter.

The Hydraulic Fluid reservoir must be filled with Hydraulic Fluid before operation. Hydraulic Fluid L-HV 46# is recommended; for low temperature locations use 32#. Viscosity of the Hydraulic Fluid should be 15-46 Centistokes (cSt). ATF Dexron III is also acceptable. Biodegradable Hydraulic Fluid may be used if it is abrasion-resistant and compatible with NBR O-Rings. Automotive Engine Oil is prohibited. See figure below.

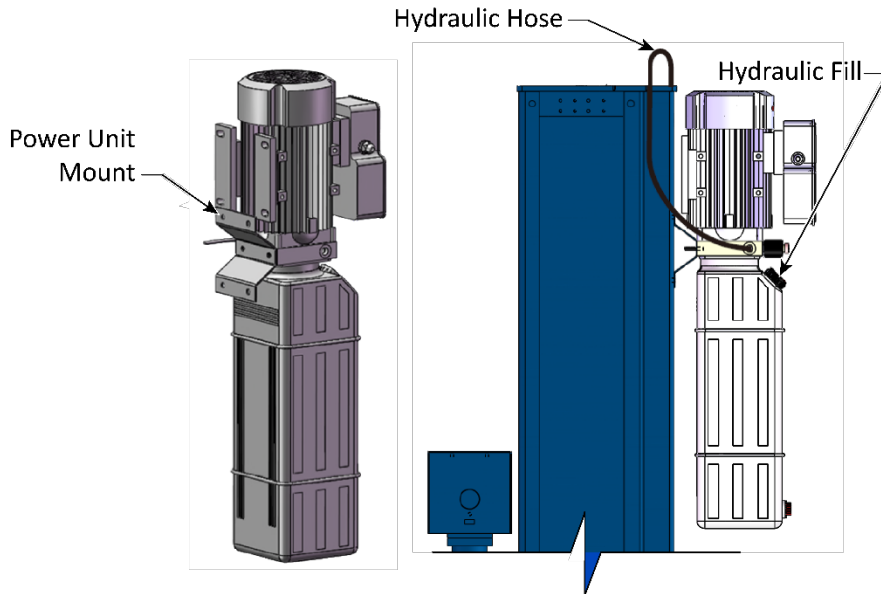

- Install the ORB Fitting on the P2 Port, apply a few drops of Hydraulic Fluid to the O-ring prior to assembling. This helps to prevent damage to the O-ring during assembly. **Verify the unused Port is plugged.**
- Connect the Hydraulic Hose from the Cylinder to the ORB fitting just installed on the Power Unit P2 Port. Verify the unused P1 Port is plugged. See figure below.

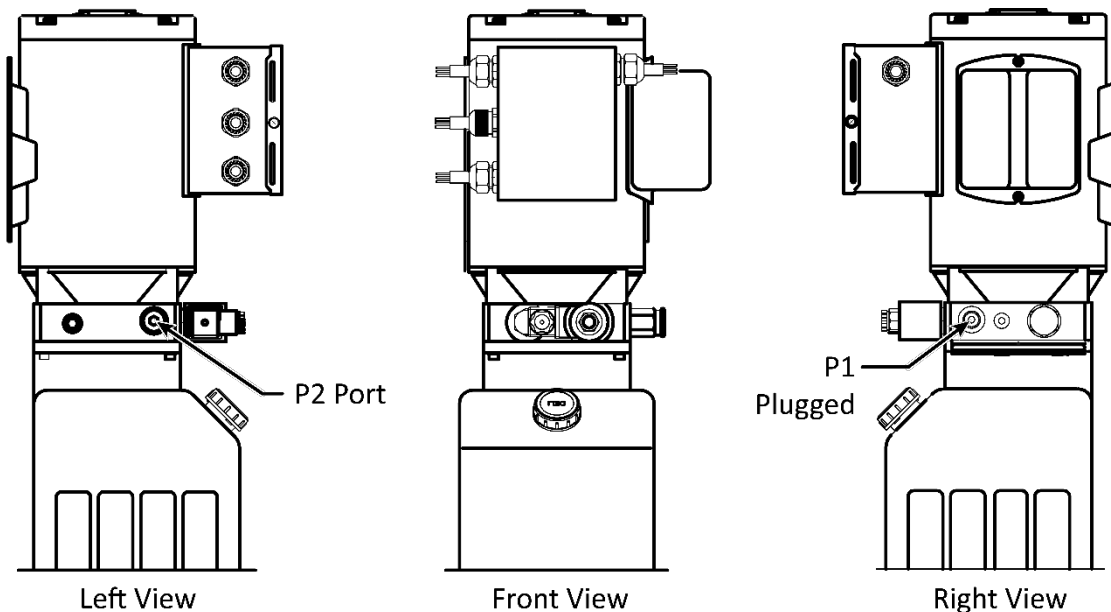

Install the Safety Lock Release Angle

The Safety Lock Release Handle is mounted to the Control Arm. The Safety Locks are released by the Safety Lock Release Handle linked by Wire Rope to a Safety Release Angle mechanism on the Powerside Post.

To Install the Safety Lock Release Angle:

Install the Safety Release Angle (a) on the front side of the Powerside Post. The release angle functions a part of the Safety Lock Release mechanism. It is supported by a Rocker Arm (b) and two smaller Straight Arms (c and d). Secure using M6 x 25 Hex Head Bolt and M6 Locknuts. Attach the Rocker Arm using M6 x 35 Hex Head Bolts and Locknuts. Verify the mechanism moves freely after securing the fasteners. Review the figures and details below.

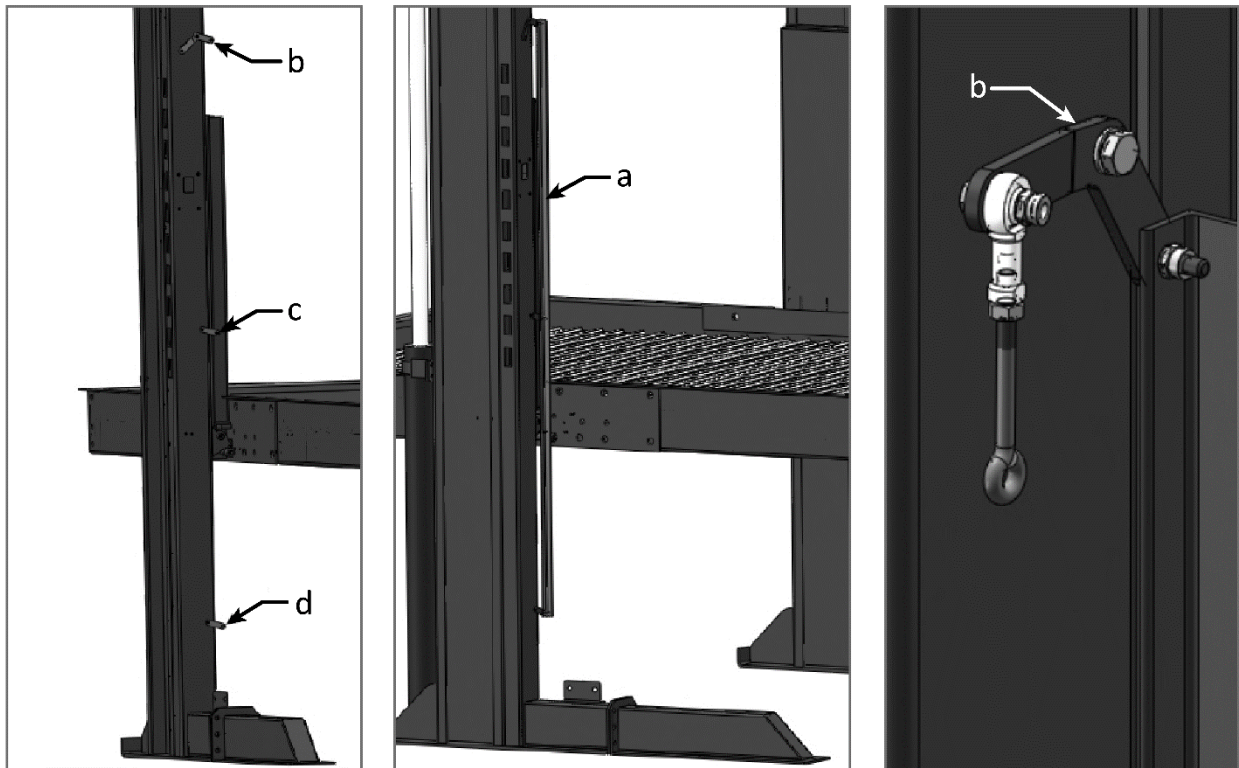

Drawing not to scale.

Safety Lock Angle Parts Detail

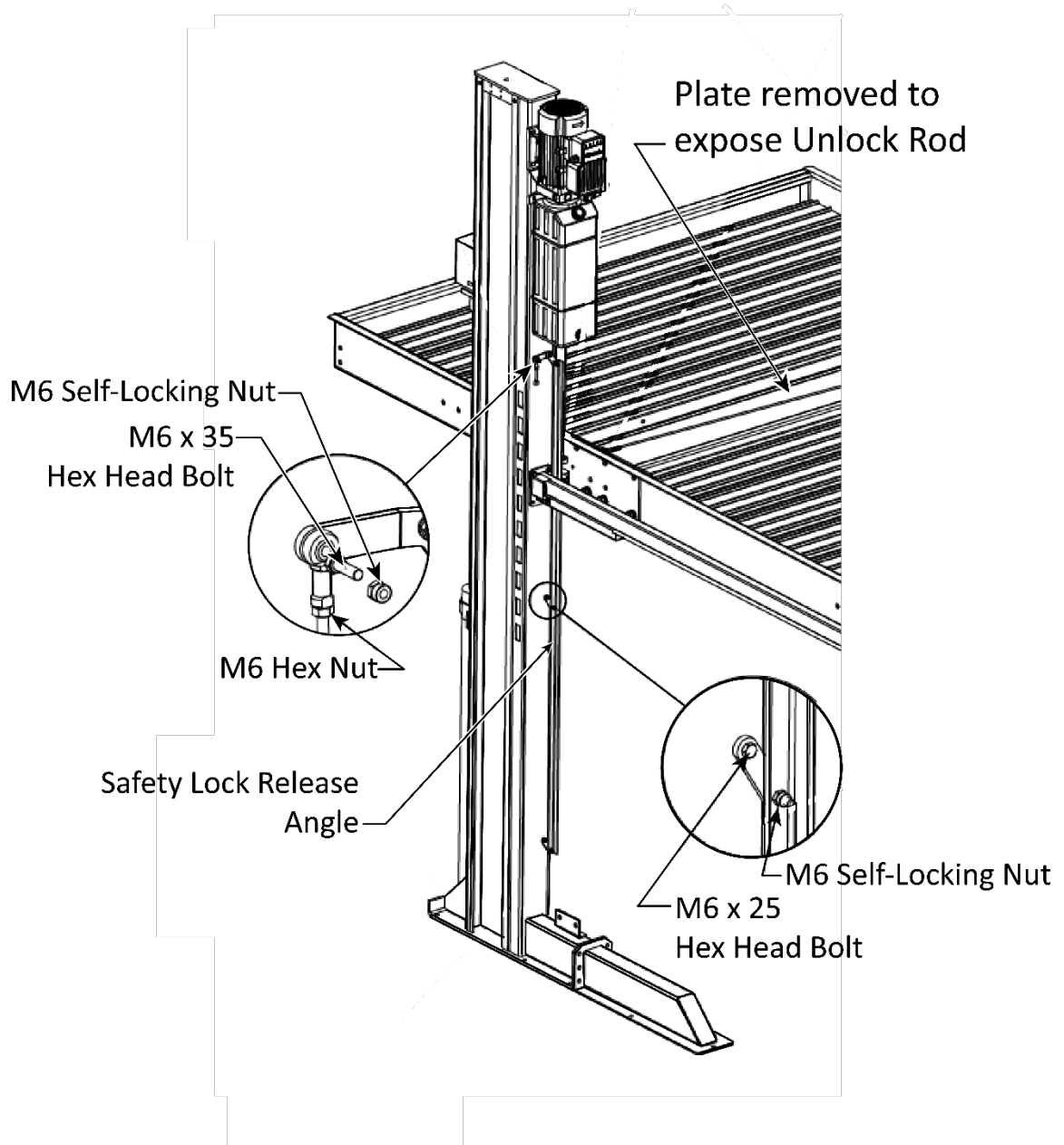

Drawing not to scale

Installing the Control Arm

1. Route the wiring from the Control Panel box through the Control Arm.

Mount the Control Panel box on the front of the Control Arm. Attach the Control Panel and Box onto the Control Arm using (4) four M4 x 20 Phillips Machine Screws and (4) four M4 Hex Nuts.

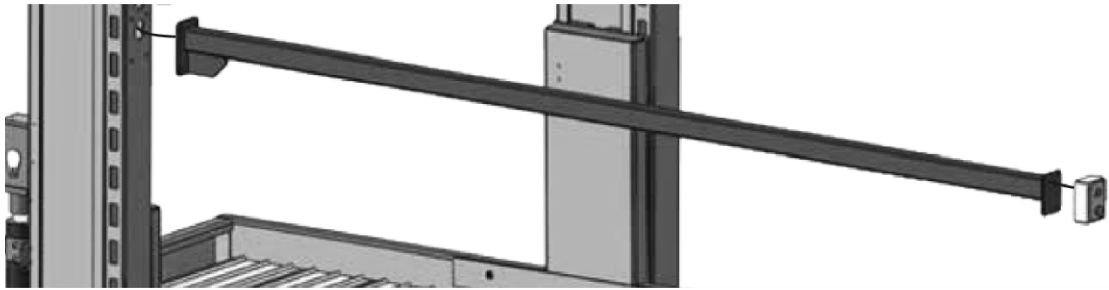

2. Route the Control Panel wires through the Control Arm into the Powerside Post, then up and out through a hole near the top of the Powerside Post. See figure below.

Run the Control Box wires through the Powerside Post and then into the Junction Box on the Power Unit. See [Control Panel Wiring Diagram](#) for reference.

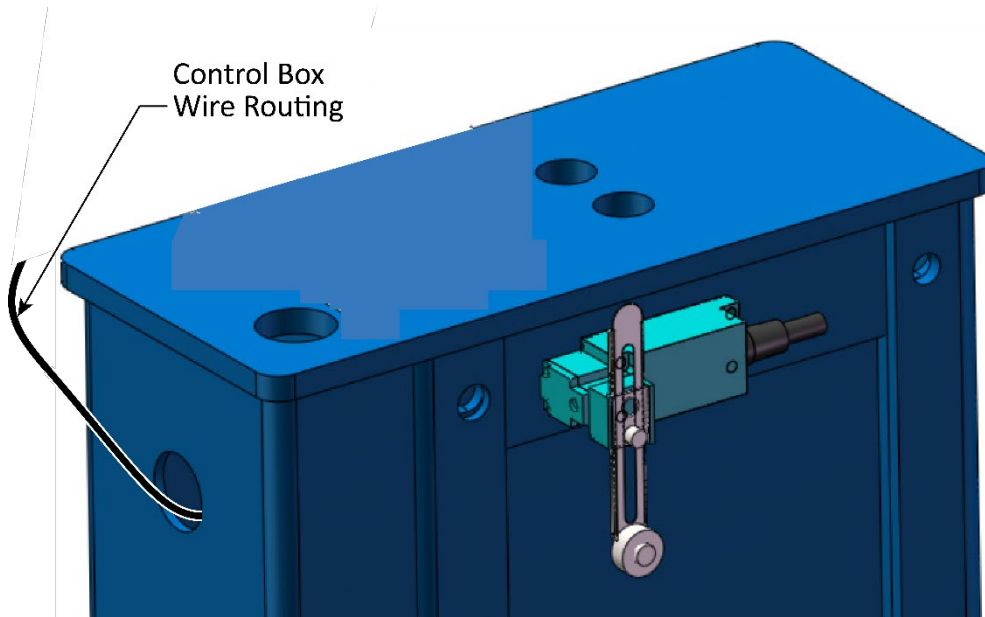

Connecting the Safety Lock Release Cable

A Wire Rope connects the Safety Lock Release Handle to the Safety Lock Release Mechanism. The Wire Rope is factory installed and routed from the Release Handle through the Control Arm, around a Sheave and then up and out of the Control Arm to be attached to the Rocker Arm on the Release Mechanism. Refer to the figures below.

To Attach the Safety Lock Release Cable:

1. Route the Release Cable from where it exits the Control Arm up to the Rocker Arm on the Release Mechanism. Refer to the figures below.

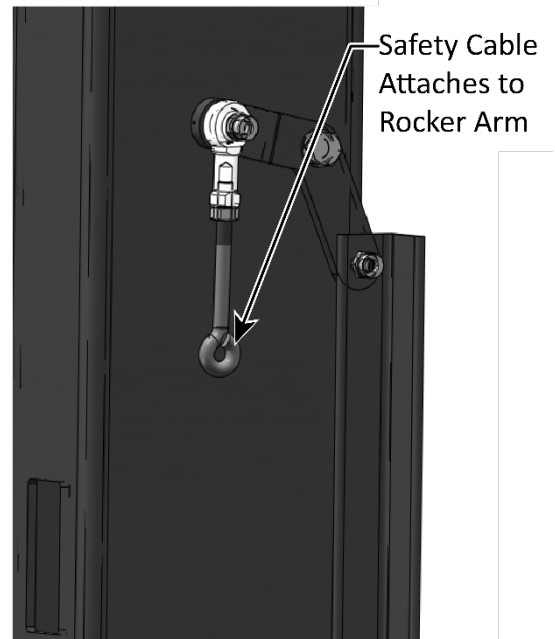
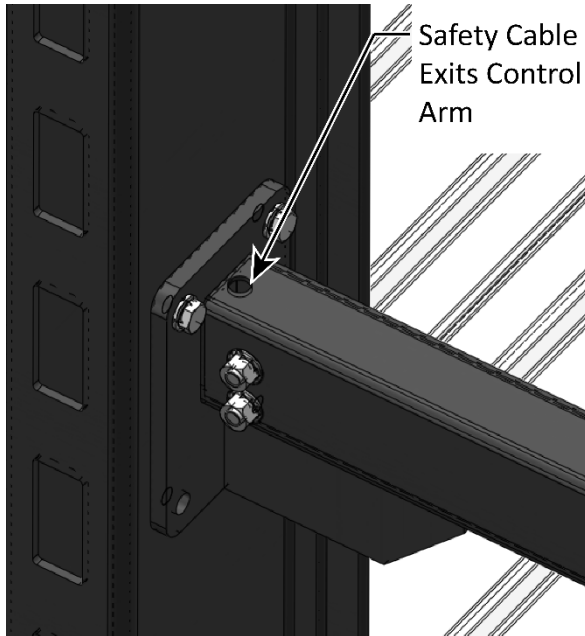

1. Connect the end of the Safety Release Cable from the Control Arm through the Rocker Arm Assembly eyelet.
2. While holding cable's looped end with the Release Cable, install and tighten the provided Clamp Assm. (5595724)



3. Adjust the Safety Release Cable tension using the Wire Rope Clamp until a smooth motion is achieved on the Safety Release Mechanism, when pulling on the Manual Safety Lock Release Handle.
4. Ensure the that Clamp Assembly is securely tightened.

Installing the Tire Stop, Lift Platform Plates and Ramp

The Tire Stop and Lift Platform Plates provide support for the Vehicle being lifted, while the Ramp is an inclined plane easing the Vehicle's entrance to the Lift.

To install the Lift Platform Plates and Ramp:

1. Install the Tire Stop next to the Back Plate. Refer to the figure below.

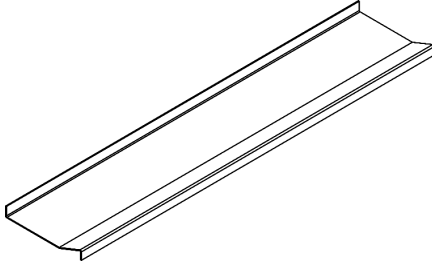

2. Place 14 Lift Platform Plates from the Tire Stop to the front of the Lift. Rocking the Side Beams and Posts allows a larger clearance for the plates, if required. Push the Platforms toward the Back Plate as you load them in. Refer to figure below.

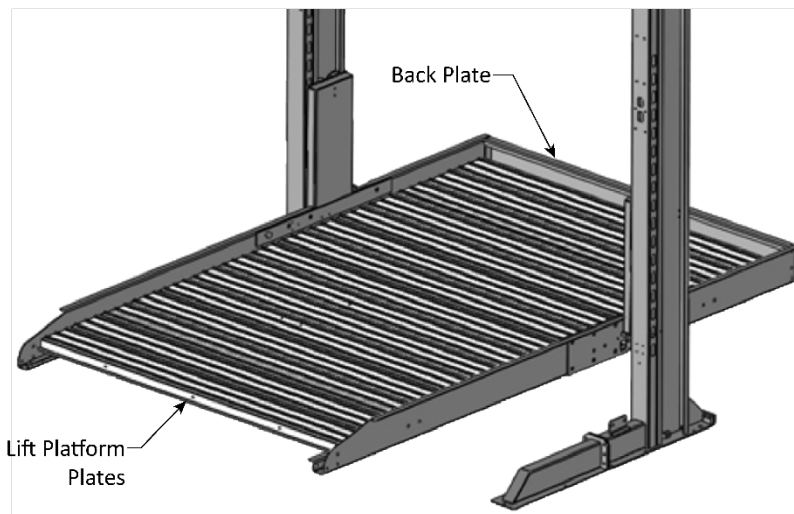

3. Install the Ramp and connect to the Side Beams using two M14 x 100 and one M14 x 40 Hex Head Bolts, Ø14 mm Lock Washers, Ø14 mm Washers and M14 Hex Nuts. **Do not tighten fasteners**, leave finger tight. Bolts will be tightened during the **Operational Test**.

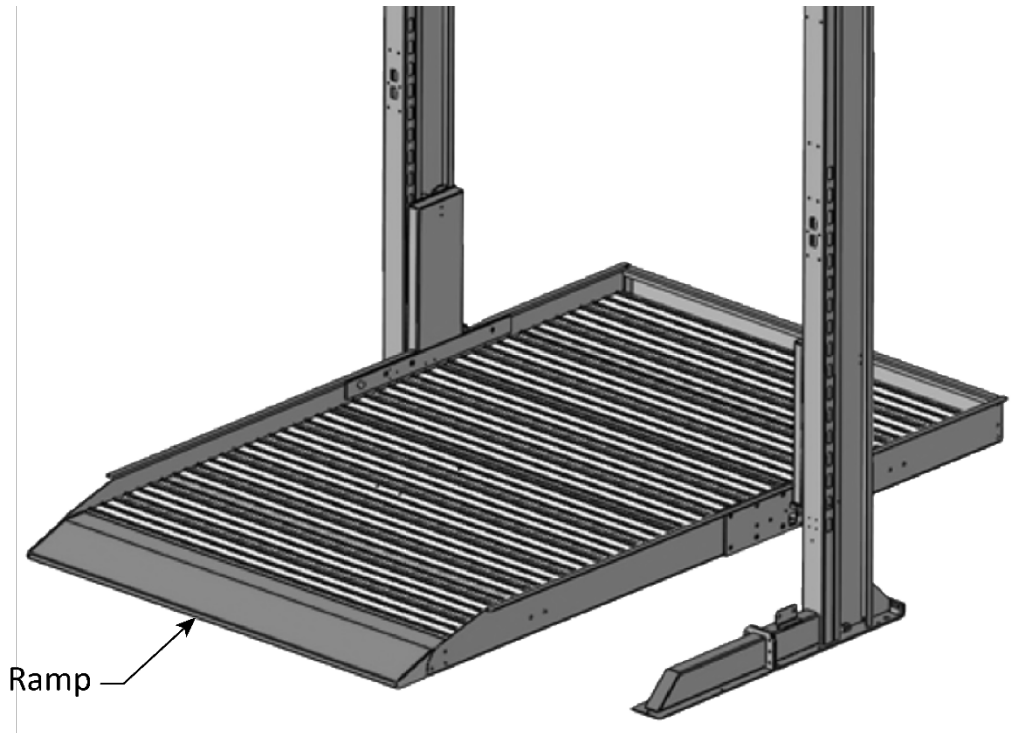

Drawing not to scale.

4. Secure the Platforms together using M8 x 20 Hex Head Bolts and M8 Flange Nuts.
5. Attach the Unlock Rod Support beneath the Platform in the center. Refer to the figure below.

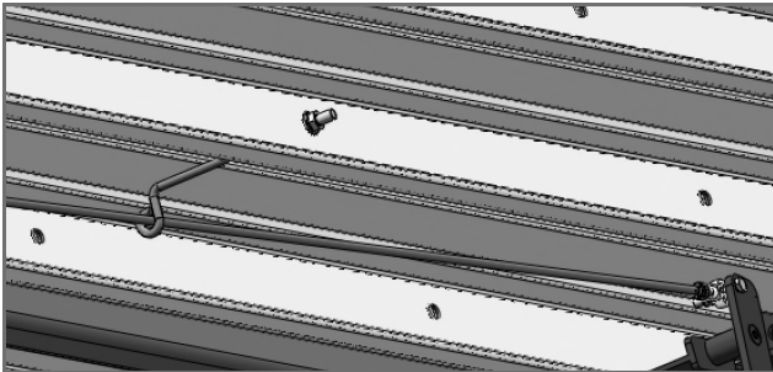

Contact an Electrician

Connecting the Lift to the electrical system requires a certified and licensed Electrician.

⚠ DANGER All wiring **must** be performed by a licensed, certified Electrician in accordance with all applicable national and local electrical codes.

Important: The Lift components do not include a Power Disconnect Switch. When you contact the Electrician advise them that a UL-Listed Power Disconnect rated for 220 VAC, 25 Amps minimum is required.

The Electrician is required to:

- **Install a Power Disconnect Switch.** The Power Disconnect Switch ensures the operator can quickly and completely interrupt power to the Lift in the event of an electrical fault, emergency or when the Lift is undergoing service. The Disconnect Switch must be installed within sight and reach of the Lift Operator. Refer to **Install the Power Disconnect Switch** for more information.
- **Install a Thermal Disconnect.** Install a Thermal Disconnect (if required by local electrical codes).
- **The motor on the Power Unit is not thermally protected.**
- **Connect the Power Unit to a 220 VAC power source.** Refer to **Connect to Power**.
- **Wire the Power Unit Junction Box.** Make the connections in the Junction Box including the controls to raise and lower the Lift Platform, the Limit Switch, the Lowering Solenoid, and Power both to and from the Power Disconnect to the Power Unit. Refer to **Wire the Power Unit Junction Box** for more information.

The Electrician must provide:

- A UL Approved Power Disconnect Switch and mount the switch on the Lift.
- A Thermal Disconnect (the power unit's motor is **not** thermally protected).
- An appropriately sized cord grip or strain relief for the Limit Switch wiring and creating an opening in the Power Unit's Junction box.
- Wire of the appropriate gauge for the voltage, current and distance to the Lift. As well as conduit to protect and route the wiring to the Lift from the Electrical service protected by an appropriate circuit breaker.

Refer to the **Wiring Diagram** for further Information.

Install the Power Disconnect Switch

⚠ DANGER All wiring **must** be performed by a licensed, certified Electrician in accordance with all applicable national and local electrical codes. Do not perform any maintenance or installation on the Lift without first verifying that main electrical power has been disconnected from the Lift and cannot be re-energized until all procedures are complete.

⚠ DANGER Verify the Lift is resting on a Safety Lock or on the ground **before** performing any maintenance. Do not work on the Lift if the Safety Locks are not engaged, you could be injured or killed.

⚠ WARNING A Power Disconnect Switch is not provided with this equipment.

Important: The Lift controls include an Emergency Stop Button, which will stop the Lift immediately when activated. This is **not** the same thing as a Power Disconnect Switch.

The Power Disconnect Switch is a National Electrical Code (NEC) requirement. The Disconnect Switch is designed to completely interrupt electrical power to the Lift.

Install a Disconnect Switch that is UL-Listed and appropriately rated for the electrical load presented by the Power Unit and the incoming electrical power.

The Power Disconnect must be readily accessible and installed so that it is within easy reach of the Lift Operator. The Disconnect must be clearly and legibly marked. The Switch itself and its Conduits or Wiring should not interfere with any of the Lift's mechanical functions or controls.

The figure below details one possible location for the Power Disconnect, above the connection for the Control Panel. Refer to the [Wiring Diagram](#) and [Control Panel Wiring Diagram](#) for further information.

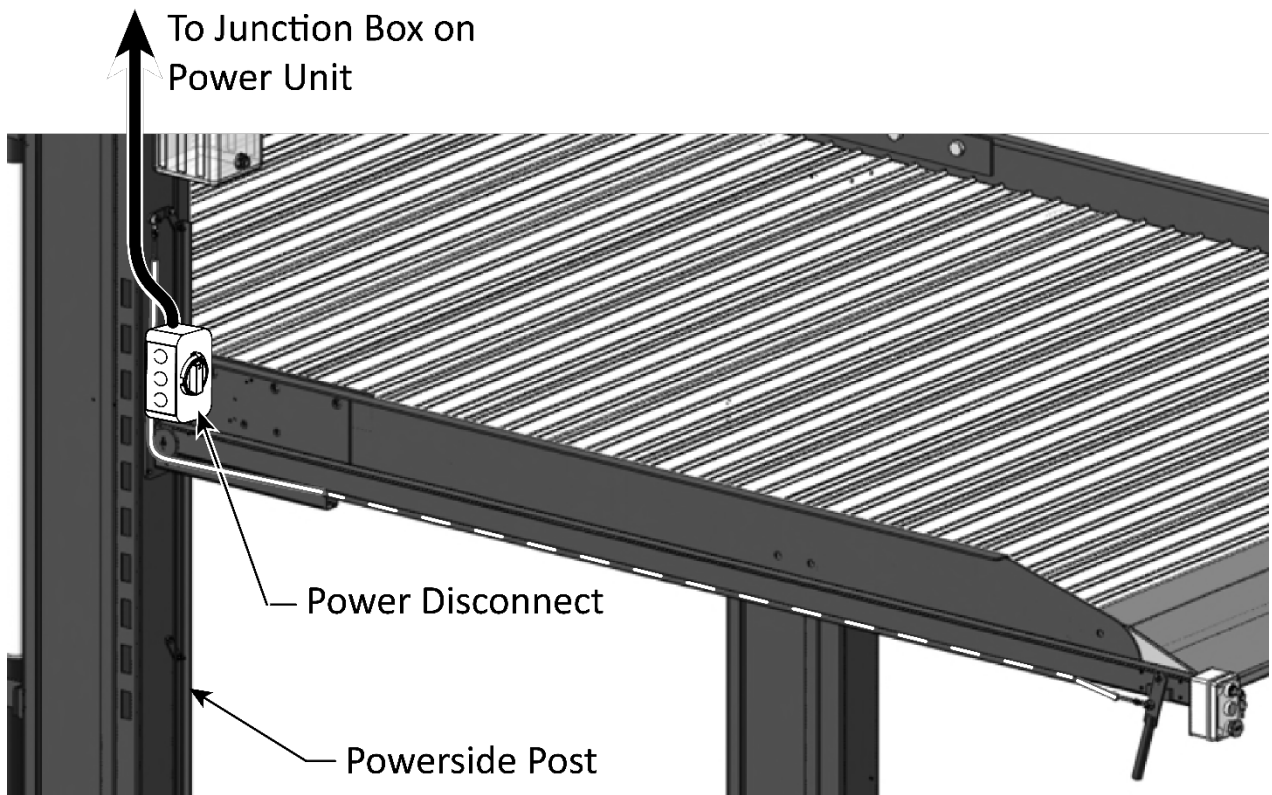

Install a Thermal Disconnect Switch

The Power Unit supplied with this Lift **does not** include thermal overload protection. Under NEC 430, UL 201, and CSA C22.2 No. 68 intermittent duty motors are not required to include thermal protection. Local electrical codes may vary, and other requirements may exist that the installing electrician will address, if required.

⚠ DANGER If local Electrical codes require the installation of a Thermal Disconnect, the disconnecting device and the installation **must** be provided by a licensed Electrician in accordance with local electrical codes. Do not perform **any** maintenance or installation on the Lift without first verifying that main electrical power has been disconnected from the Lift and **cannot** be re-energized until all procedures are complete.

Install the Limit Switch Cord Grip and Wiring

Several different Hydraulic Power Units may be supplied with this Lift and there may be minor variations in appearance. Using a conduit Knockout Punch create a hole in the Power unit's Junction Box in an area that will not interfere with the existing electrical or mechanical components. A suggested location is pictured in the sketch below. Install the Thermal Disconnect in accordance with local electrical codes and the manufacturer's instructions.

Refer to the [Wiring Diagram](#) and [Control Panel Wiring Diagram](#) for further information.

NOTE: Several different power units may be supplied with your Lift based upon availability and may not look exactly as pictured below.

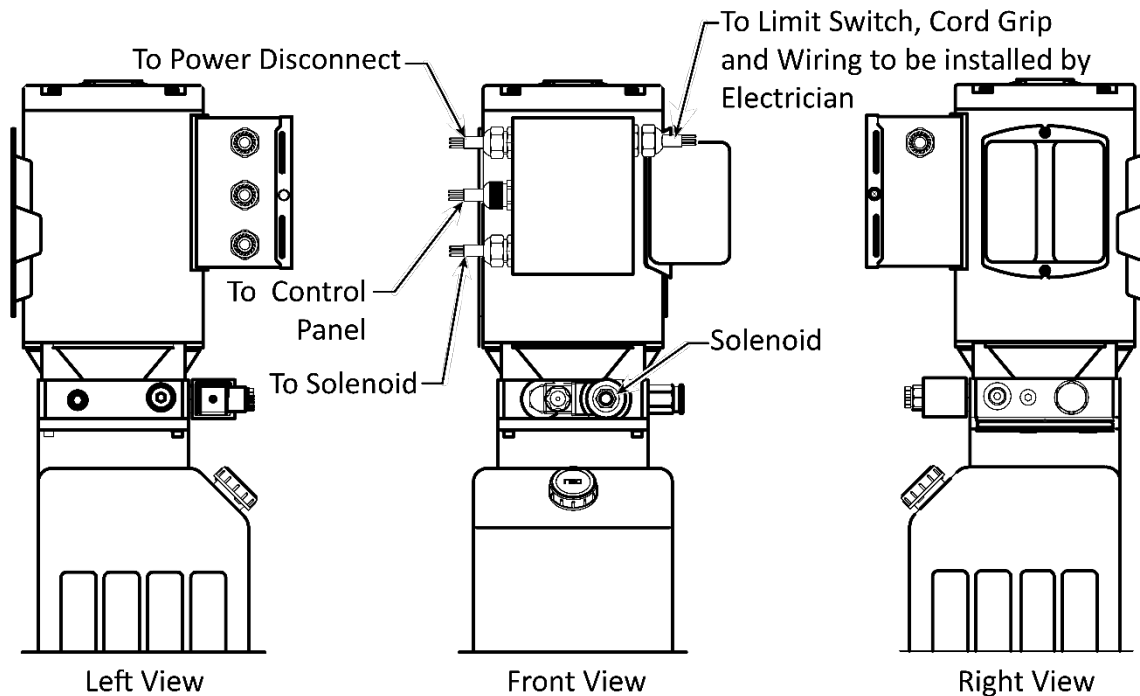

Connect To Power

Connect the Power Unit to an appropriate Power Source through the Power Disconnect Switch.

Power for this Lift is 220 VAC, 60 Hz. single phase and should be protected by an appropriately rated fuse or circuit breaker.

Refer to the [Wiring Diagram](#) and [Control Panel Wiring Diagram](#) for further information.

⚠ DANGER All wiring **must** be performed by a licensed Electrician in accordance with all applicable national and local electrical codes. Do not perform any maintenance or installation on the Lift without first verifying that main electrical power has been disconnected from the Lift and cannot be re-energized until all procedures are complete.

⚠ WARNING Keep Wiring and Hydraulic Hoses away from sharp edges or pinch points to avoid damage.

Important Electrical Information:

- Improper electrical installation can damage the Power Unit Motor. This damage is **not** covered under warranty.
- Use a separate Circuit Breaker for each Lift Installed.
- Protect each circuit with an appropriate time-delay fuse or circuit breaker.

To connect the Lift to Power:

1. Verify the Power is disconnected and locked out to prevent re-energizing while you work on the Lift.
2. Connect the Main Power Supply wiring to the Power Disconnect Switch just installed using an appropriate gauge wire for the voltage, current and length of run.
3. Route the Power wiring from the Power Disconnect up to the Junction Box on the Power Unit.
4. Refer to the [Wiring Diagram](#) and [Control Panel Wiring Diagram](#) to connect the power to the Contactor and Thermal Disconnect, the Solenoid, and Control Panel in the Junction Box.

Wire the Power Unit Junction Box

The Junction Box houses the wiring and connections for Power, Thermal Overload (if required), Limit Switch, Solenoid and the Lift Controls. The Controls on the Console allow the operator to raise and lower Vehicles. Refer to the figure above and the [Wiring Diagram](#) and [Control Panel Wiring Diagram](#) for wiring information.

⚠ DANGER All wiring **must** be performed by a licensed, certified Electrician in accordance with all applicable national and local electrical codes.

The Junction Box wiring includes:

- **Power.** Wiring connections for power supplied to the Hydraulic Power Unit from the Power Disconnect Switch.
- **Control Panel.** This wiring includes the Up, Down and Emergency Stop Lift functions.
- **Limit Switch.** This Switch stops the upward motion of the Lift Platform.
- **Solenoid.** The Solenoid opens the Hydraulic Valve allowing the Lift Platform to Lower.

To Wire the Junction Box:

1. Verify power is disconnected and locked-out before beginning any work on the Lift.
2. Verify the control panel wiring. A **Control Panel Wiring Diagram** is included for your reference.
3. Connect the Control Panel wiring to Power, the Limit Switch, Power Unit and Solenoid as indicated by the **Wiring Diagram**.
4. Verify the wiring against the Wiring Diagram before applying Power to the Lift.

First Operational Test and Level Adjustment

1. Apply power to the Lift and raise the platform approximately 70 in. / 1800 mm.
2. Adjust the Balance Chain. Using a four-foot Level, measure and adjust the level of the platform using the threaded rod on top of the Offside Post. Check the level condition of the platform in at least four places to verify the Platform is level front to back and side to side.
3. Verify the levelness and perpendicularity of the Offside Post. Verify that both posts are parallel to each other. Shim Lift Posts as required to make perpendicular. Do **not** exceed .5 in (12.7 mm) in Shim height.
4. Operational Test one. Operate the Lift from ground to maximum height at least two times.
5. At the completion of this test, verify the Posts are parallel and the Lift Platform is level. **A = B** and **A1 = B1**. Refer to the figure below.

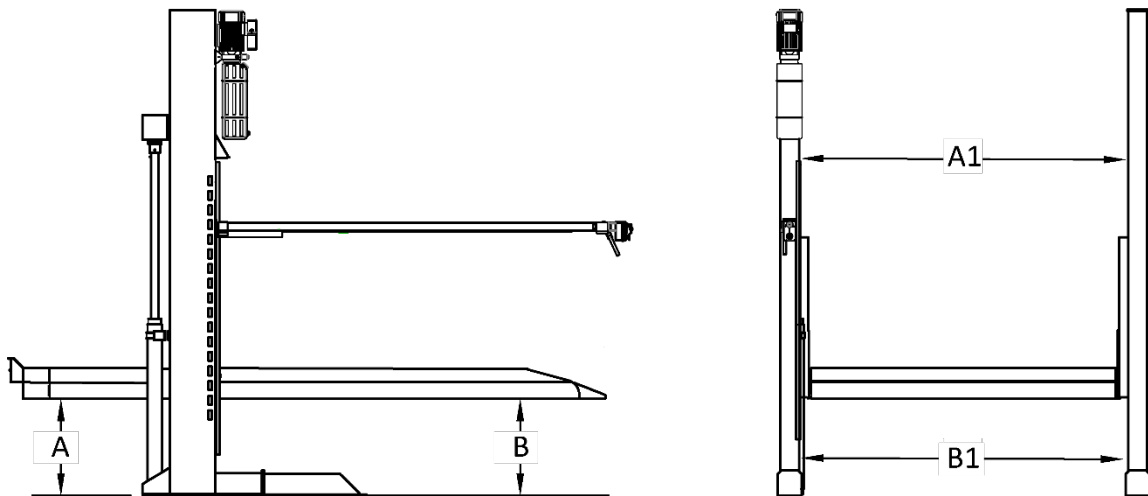

6. Measure the diagonal distances of the Lift Platform corner to corner. Verify the diagonals are equal within .25 in. (5mm). Adjust as required to make the diagonals equal.
7. **Tighten all bolts and fasteners** on the Platform and the Lift Structure, **except** the Anchor Bolts. Final tightening of the Anchor bolts will be completed after drilling the Offside Post Anchors.

Adjusting the Safety Locks and Safety Release

1. Perform a visual inspection of the Safety Release System as the Lift is moving up and down.
2. Rotate the two ends of the Adjustable Joint clockwise and counterclockwise to verify that the locks may be easily unlocked when pulling the Safety Release Handle and will also engage the Locks when the Safety Release Handle is released. Refer to the figure below.

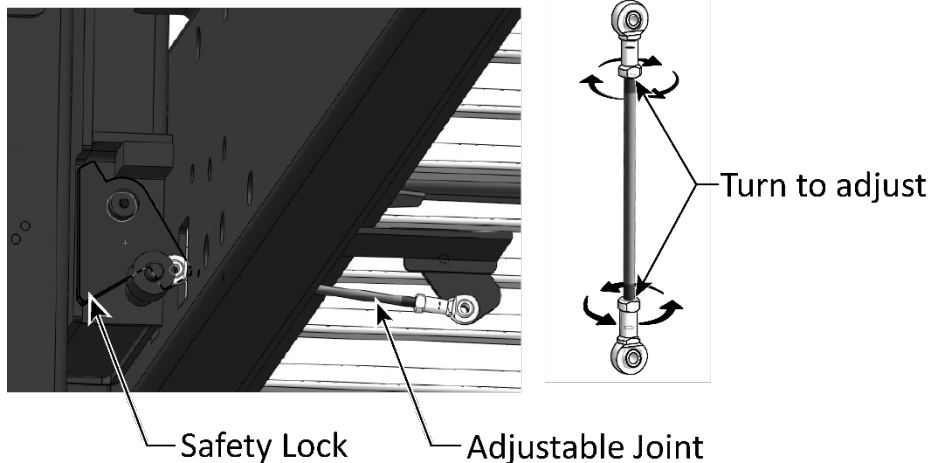

3. Operational Test Two. Run the Lift up and down (5) five times while verifying the Safety Locks are engaging/disengaging correctly, that the Lift does not jerk or jump as it runs.
4. Verify the Hydraulic Fluid level is correct with the Lift on the Ground.

Adjusting the Limit Switch

The Limit Switch will stop the upward motion of the Lift and may be adjusted within the range of the Limit Switch Arm travel. When mounted at the top of the Lift Post, adjust the Limit switch to the 5 or 7 o'clock position to trigger when the Lift Carriage contacts the Limit Switch Actuator Arm. Additionally, the Limit Switch may be mounted to a bracket allowing the switch to be moved up and down the Post using the Optional Mounting Bracket supplied. Refer to the figure below.

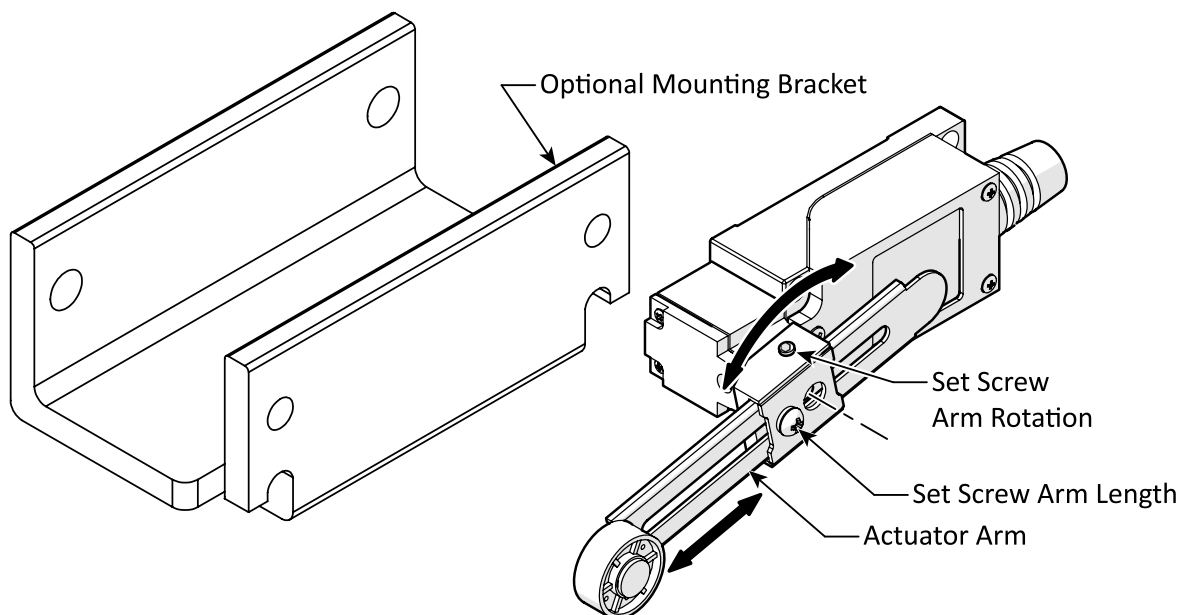

Drill the Offside Post Anchors

 **WARNING** You **must** always wear OSHA-approved (publication 3151) appropriate protective equipment during installation: leather gloves, steel-toed work boots, eye protection, back belts, and hearing protection are **mandatory**.

1. Carefully drill the 12 mm Anchor Bolt holes 130 mm deep for the Offside Post. Refer to **Anchoring the Powerside Posts** to reference the drilling procedure.
2. Carefully clean the holes using compressed air and vacuum, then insert the anchors. Thread the Washers and Hex Nuts onto the Anchors but leave finger tight. Do **not** tighten.
3. Drill the Front Support Anchor Positions Ø12 mm x 130 mm deep, vacuum, and clean holes as done in the Powerside Anchor procedure. Insert the Anchors and assemble with the Washer and Hex Nuts finger tight. Do **not** tighten.
4. Operate the Lift up and down again (5) five times. Verify every part of the Lift is working correctly, free from obvious noises or abnormalities.
5. If the Lift is operating correctly, **tighten all anchor bolts**.

Lubrication

Keep the moving parts of the Lift lubricated to protect and extend the life of the Lift:

- **Weekly to Monthly**. Lubricate the Balance and Lifting Chains. The frequency of chain lubrication is dependent on the operating environment. Refer to the **Maintenance Section** for lubricant specifics and frequency.
- **Monthly**. Lubricate the inside of the Lift Posts where the Rubber Slides travel with White Lithium Grease.
- **Monthly**. Lubricate the Sliders on the Carriages with White Lithium Grease.

Operational Test

BendPak recommends performing an Operational Test of your Lift with a typical Vehicle **before** beginning normal usage.

Performing an Operational Test will help you get a feel for how to operate the Lift and helps to purge any residual air out of the Hydraulic System.

During the Operational Test, watch the operating components and check for proper installation and operation. If you run into an issue that does not go away, refer to **Troubleshooting** for more information.

Note: Residual air in the Hydraulic System can cause the Lift to shake, move erratically, or squeak; this is normal. These noises and movements will gradually decrease, then cease after a few up-down cycles as the Lift Hydraulics self-bleed.

To perform an Operational Test:

1. Check the area around and above the Lift for obstructions; move them if you find any.
2. If you are going to run the test with a typical Vehicle, drive it onto the Lift Platform.
3. Insert the key, turn it to the left (counterclockwise) toward **Up** on the control, to raise the Lift Platform.

-
4. When the Platform is about a foot off the ground, release the Key. The Key will return to the center neutral position and the Lift Platform will stop rising.
 5. Turn the Key to the Right (clockwise) toward **Dn**. The Lift Platform begins to lower.
 6. When the Platform gets to the ground, release the Key. The Key will return to the center neutral position.
 7. Wait for one minute.

 **CAUTION** The Power Unit's motor is **not** constant duty; it cannot be run continuously.

8. Repeat the process, this time raising the Platform to the first Safety Lock.
9. If the Platform is working without shaking, moving erratically, or squeaking, there is no need to repeat the procedure.

If the Platform is shaking, moving erratically, or squeaking, this is perfectly normal during the start-up period. Repeat the procedure one or two more times, with a one-minute break between. The Hydraulic System is self-bleeding.

10. If additional Lifts are installed, perform the same test with all the connected Lifts.
11. If you used a Vehicle for the testing, check the Platform Sections to verify they stayed in place and all fasteners are secure.
12. Check the Hydraulic Fluid reservoir on the Power Unit.

NOTICE Bleeding the Hydraulic System may significantly lower the amount of Hydraulic Fluid in the reservoir. Add additional Hydraulic Fluid if necessary.

If there are issues that remain, refer to **Troubleshooting** for more information.

Final Checklist before Operation

Make sure these things have been done before using your Lift:

- Review the **Installation Checklist** to make sure all steps have been performed.
- Verify the Power Unit is getting power from the power source.
- Check the Hydraulic Fluid reservoir; it must be full of approved Hydraulic Fluid or Automatic Transmission Fluid. **You can damage the Power Unit by running it without enough fluid.**
- Check the Hydraulic System for leaks. Verify all Hydraulic Hose connections, Hydraulic Fittings, and Auxiliary Port Plugs on the Lift and Power Unit are tight.
- Check the Lift Platform Sections to verify they are bolted securely and in place.
- Verify sure all Posts are properly anchored, shimmed, level, and stable.
- Verify all Chains are taut, correctly routed, and properly positioned and lubricated.
- Verify all Safety Locks are working normally.
- Make sure to leave a copy of the *Installation and Operation Manual* with the Lift.
- If it has not been done already, perform an operational test of the Lift.

Operation

This section describes how to operate your Lift.

 **DANGER** When you even hear the words “automotive lift,” your brain should automatically remember that lifting a Vehicle is a serious endeavor with life-threatening risks. Focus on what you are doing. Automotive Lifts are dangerous tools when used by inexperienced or impaired operators. **Do not assume you are going to be safe this time because nothing happened last time.**

Safety Considerations

Do the following before you raise or lower a Vehicle:

- **Check the Lift.** Walk all the way around the Lift, checking for any missing, heavily worn, or damaged parts. Always verify all Hydraulic connections including Hydraulic Fittings, Hoses, and Auxiliary Ports are secure. Do not operate the Lift if you find any issues; instead, take it out of service, then contact your dealer, email support@bendpak.com, or call **(800) 253-2363**, follow the prompts to reach support.
- **Check the area.** Keep the area around the Lift clean and free of obstructions; anything that could cause a problem for the Lift or interfere with driving a Vehicle onto or off the Lift. Do not forget to check **above** the Lift. If you find an obstruction, move it out of the way. If you find any other issues, resolve them before using the Lift. Do not allow anyone or anything within 10-feet (3 meters) of the Lift while it is in motion.
- **Check the operators.** Make sure that everyone who is going to operate the Lift has been trained in its use, has read the Labels on the unit, and has read the Manual. Only the operator at the Console should be within 30 feet of the Lift when it is in motion.

Do not allow children to operate the Lift. Do not allow anyone under the influence of drugs or alcohol to operate the Lift. Do not allow any unauthorized personnel to operate the Lift.

When the Lift is moving, the Operator must be paying full attention to the Lift and the area around it. The Operator must not be looking down at a smart phone, talking to a co-worker, or be distracted in any other way.

- **Check for safety.** Make sure everyone who is going to be walking near the Lift is aware of its presence and takes appropriate safety measures. Only put Vehicles on the Platforms. **When raising a Vehicle, do not leave it until it is on a Safety Lock.** When lowering the Lift, do not leave it until it is on the ground.
- **Check the Vehicle.** Never exceed the Lift’s weight rating. Do not allow people inside a Vehicle you are going to raise. Take any articles you may need out of the Vehicle. Verify the Vehicle is not overbalanced on either end or either side.

Using the Control Panel

This section describes how to use the Control Panel.

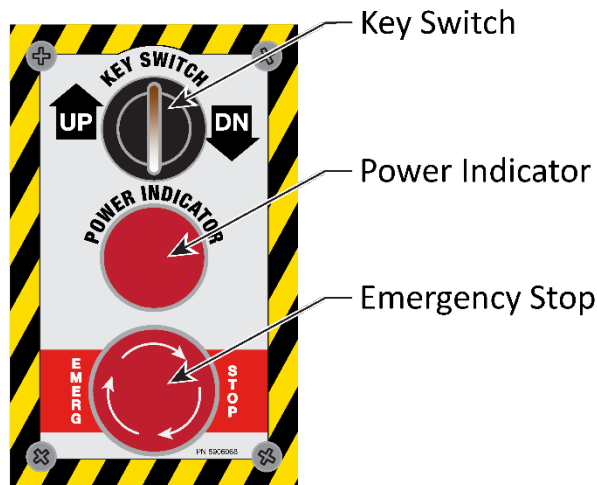

The **Control Panel** controls your Lift:

- The **Up/Dn Key Switch** is a security device; The Lift will not operate without the correct key inserted in the switch. The center Key position is a neutral position. Rotate and hold the Key to the **left** (counterclockwise) **to raise** the Lift Platform. Rotate and hold the Key to the **right** (clockwise) **to lower** the Lift Platform. The Key switch will return to the center neutral position when released.
- The **Power Indicator** is illuminated when electrical power is supplied to the Lift.
- The **Emergency Stop Button**, when pressed, stops the Lift immediately by removing power to the Hydraulic Power Unit. Use this button if an unexpected and/or dangerous situation arises. When pressed, the button physically moves inwards and locks. To release the **Emergency Stop Button**, twist it clockwise until it pops back out, restoring power.

Raising and Lowering Vehicles

Keep the following in mind when operating your Lift:

- **Be safe.** Make sure to check for people, pets, and objects that might be in the path of the Lift as you raise or lower it. Watch the Lift and Vehicle carefully as it raises and lowers.
- **⚠ DANGER** Pay careful attention when you are raising or lowering the Platforms. If a person or pet gets stuck under the Platform, they could be injured or, in rare cases, killed.
- **Vehicles must be centered on the Lift Platform.** Vehicles need to be centered on the Platform, along the left-right axis. All four wheels must also rest fully on the Platform, not the approach ramp or side structures.
- **The Emergency Stop button is there for a reason.** We hope you never have to use it, but if something unexpected happens, use the **Emergency Stop** button to immediately stop the Lift from moving.
- **Get what you need out of the Vehicle before lifting it.**

To Raise a Vehicle, Pre-Lifting Stage

1. Review the Operating Manual and all safety labels **before** using the Lift.
2. Inspect the Lift before use. If worn, broken or missing parts are found, do **not** use. Take the Lift out of service.
3. Drive the Vehicle onto the Lift Platform. The Vehicle should be centered on the Platform, and may be driven in nose first or backed in.
4. Drive until the Vehicle's tires rest against the Back Stop.
5. Place the Vehicle's gear selector in park, turn off the engine, and engage the safety brake. For Manual Transmissions shift to first gear, turn off the Engine and set the Safety Brake.
6. Check the front of the Lift to verify the Vehicle's tires are securely on the Platform.
7. Walk around the Lift to ensure there are no obstructions that could interfere with the Vehicle being lifted.
8. Position yourself in front of the Operator's Control Panel.

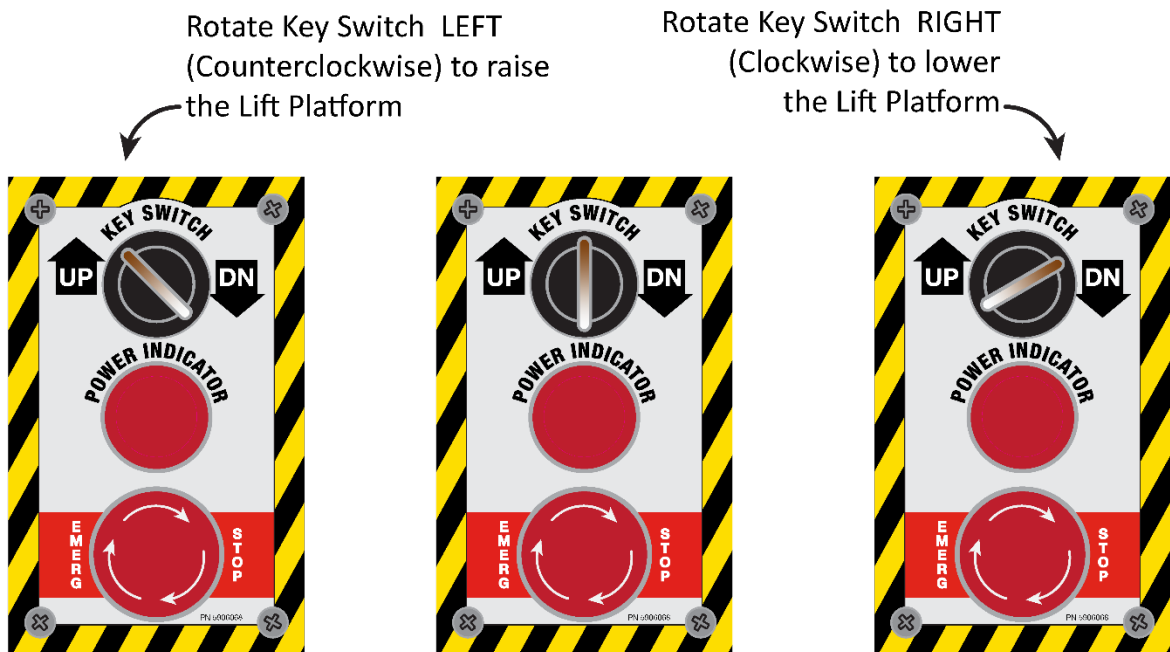

To raise a Vehicle – Lifting Stage:

1. Once all the precautions above are followed, check around and above the Lift to ensure that no objects are obstructing the Platform, and that no persons (except the Lift operator) are within 10-feet / 3 meters.
2. To **raise** the Lift Platform to the desired height, turn the Key Switch on the Control Panel to the **left** (counterclockwise) and **hold**.
3. Always raise the Lift Platform until it reaches its top Limit Switch position.
4. If a low ceiling is overhead, be cautious as you lift the Vehicle. Never allow the top of the Vehicle to come into contact with any overhead structure or object.
5. Once the top position is reached, release the Key Switch to its neutral position.

-
6. To **lower** and rest the Platform on a safety lock, rotate the Key Switch to the **right** (clockwise) and **hold** until the Lift Platform rests on a lock.
 7. Always walk around the Lift to inspect the Vehicle, never walk under the raised platform.

To park a Vehicle below the Lift Platform:

1. Once all precautions of the Pre-Lifting and Lifting Stage have been followed, drive the lower Vehicle under the Lift Platform until the Tires reach the location where the car is positioned under the Lift to allow clearance for the doors and mirrors.
2. Place the Vehicle's gear selector in Park, turn off the Engine, and engage the safety brake. For manual transmissions, shift to first gear, turn off the engine and set the safety brake.
3. When exiting the Vehicle use care not to damage the Vehicle's doors or mirrors against the sides of the Lift. Watch your head so as not to hit the underside or corners of the Lift Platform.

To remove the Lower Vehicle:

Verify the path is clear, then carefully drive the Vehicle out from underneath the Lift Platform.

To lower a Vehicle:

1. Walk around the Lift to verify there is nothing below or near the Lift Platform that could be damaged.
2. Verify that no person (except the Lift Operator) is within 10-feet of the Lift area.
3. Turn and hold the Key Switch to the **left** (counterclockwise) and raise the Lift Platform off the Safety Locks by a few inches.
4. Pull and hold the Safety Lock Release Handle, then rotate the Key Switch **right** (clockwise) to **lower** the Lift. You must hold the Safety Release Handle and the Key Switch turned full right until the Lift Platform has returned to the ground.
5. When lowering the Lift **always** be watchful for objects, persons or animals that may wander under the Lift Platform during operation. Cease operation immediately if the area under the Lift becomes obstructed.
6. Keep hands and feet clear of all moving parts and pinch points.
7. Release the Key Switch back to its neutral position upon full descent of the Lift Platform.
8. Verify the path is clear, then drive the Vehicle off the Lift Platform

Maintenance

Proper and regular maintenance will extend the life of your Lift and reduce downtime due to component failures.

⚠ DANGER Before performing any maintenance on your Lift, make sure it is completely disconnected from power. Do not reconnect it until all maintenance procedures are finished. The Lift uses electrical energy; if your organization has Lockout/Tagout policies, make sure to implement them **before** performing any maintenance. If you come into contact with high voltage/current, you could be injured or killed.

⚠ DANGER Verify the Lift is resting on a Safety Lock or on the ground **before** performing any maintenance. Do not work on the Lift if the Safety Locks are not engaged, you could be injured or killed.

If you need to replace worn, damaged, or broken parts, you **must** use parts from (or approved by) the original equipment manufacturer (OEM) or parts that meet the OEM's specifications.

⚠ WARNING If you use parts not from, approved by, or meeting the specifications of the original equipment manufacturer, you void your warranty and compromise the safety of everyone who installs or uses the Lift.

To maintain your Lift:

- **Daily:** Keep the Lift clean. Wipe up any spills and remove dirt.
- **Daily:** Make a visual inspection of all moving parts and check for damage or excessive wear. Replace any damaged or worn parts before using the Lift.

⚠ DANGER Do not use the Lift if the Lifting or Balancing Chains are damaged or extremely worn. If a Vehicle is raised when you notice the damage or wear, very carefully lower the Vehicle to the ground, if this can be done safely; if it cannot be done safely, evacuate the area and make arrangements with trained lift service personnel to lower the Vehicle. When the Lift is on the ground, take it out of service, disconnect it from power, and make arrangements with trained lift service personnel to fix the damage and/or wear.

- **Daily:** Determine the cause of any abnormal noise.
- **Daily:** Verify all safety devices are operating and in good condition.

⚠ WARNING Do **not** use a Platform if its Safety Lock is damaged or excessively worn.

- **Weekly:** Check all Controls, including Emergency Stop, to make sure they are functioning.
- **Weekly:** Check all Labels on the Lift. Replace them if they are illegible or missing.
- **Monthly:** Grease the lubrication points on the Lift. Use white lithium grease or similar.
- **Monthly:** Check Hydraulic Fluid levels in the reservoir when the Platform is at its lowest position. Refill as required.
- **Monthly:** Check the inlet filter inside the Hydraulic Oil Reservoir. Clean or replace the Filter as required.
- **Monthly:** Check Hydraulic Hoses for cracks, abrasion, or leaks. Replace as required.
- **Monthly:** Check power supply wiring, if possible. Replace any wiring with cracked or damaged insulation.

- **Monthly:** Check Hydraulic Hoses and connection points for leaks. Tighten or replace fittings as required.
- **Monthly:** Check the Power Unit temperature regularly. Temperature should range from -10° to +60°C.
- **Monthly:** Check Cable and Chain connections, bolts, and pins for proper mounting and torque.
- **Monthly:** Lubricate the Guide Rail, Guide Pulley, and Balance Chain
- **Every two months:** Check all Anchor Bolts to make sure they are correctly tightened. If they are not, tighten them.
- **After the first 3 months of operation:** Remove and replace the Hydraulic Fluid. Change the Hydraulic Fluid every 24 months thereafter. Dispose of used Hydraulic Fluid according to national and local environmental regulations.
- **Every six months:** Clean the Solenoid Valve and Filter in the Power Unit.
- **Every nine months:** after the first Hydraulic Fluid change, replace the Hydraulic Fluid.
- **Every two years:** Replace the Seals in the Hydraulic Cylinder.
- **Every two years:** Inspect the Slide Blocks and replace, if required.
- **Every two years:** Replace the Lift Drive Chain Roller.
- **As needed.** Take the Lift out of service and then replace the Lifting Chain and Safety Locks if there are signs of damage or extreme wear.
- **If left unused for long periods, BendPak recommends that:**
 - Power is turned off and locked off at the main Power Disconnect.
 - Drain the Hydraulic Fluid Reservoir. Dispose of used Hydraulic Fluid in accordance with national and local environmental regulations.
 - Apply rust preventative on the Balance and Lift Chains regularly.
 - Apply lubrication to moving parts that may be damaged by rust or exposure to moisture.

⚠ WARNING Do not operate your Lift if you find maintenance issues; instead, take the Lift out of service, then contact your dealer, visit bendpak.com/support, email support@bendpak.com, or call **(800) 253-2363**, follow the prompts to reach support.

To maintain the Lift Cylinder:

Only trained qualified personnel should be permitted to inspect, service and maintain the Lift Cylinder.

1. Verify the actual working pressure and system supply pressure is adequate.
2. Verify the Hydraulic Fluid working temperature and Cylinder cleanliness are within tolerance.
3. Inspect the exposed areas of the Cylinder Rod for foreign particles or dirt adhered to the surface; remove as required.
4. Regularly check the Cylinder for leaking on the Hydraulic Port, the Cylinder Rod and the junction of the Bore and the Rod.
5. Clean the Cylinder Vent Hole on a quarterly basis.
6. Keep the Hydraulic Fluid clean by replacing regularly.
7. Inject Lubricating Oil through the Vent Hole into the lower cavity of the Cylinder, until the Lubricating Oil is forced out of the Vent Hole when the Lift is fully raised.
8. Keep the Hydraulic Vent Hole clear of dirt and foreign material to prevent them from entering the Cylinder.

9. Low-Speed and Jerky movement of the Lift Cylinder should be checked to avoid damage to the Cylinder.
10. Score marks and scraping of the chromium on one side of the Cylinder Rod indicates significant wear, requiring dismantling of the Cylinder to inspect and remove/replace the worn components.
11. Check the Hydraulic Fluid Port, Vent hole and Wiper Seal at the Cylinder Head End. Replace broken Seals if leaking is occurring.

To Maintain the Chains:

- Regularly inspect the Balancing and Lifting Chains for wear or damage.
- Check for wear or abrasion loss. Replace the entire Chain if the length is 2% or more than the standard length.
- Verify the Chain Transmission Wheels are properly aligned, and the Chain is unobstructed.
- Keep Chains well lubricated. (High viscosity grease is not recommended. Dirt will readily adhere to high viscosity grease and ultimately cause excessive wear and friction.
- Clean debris from the Chains regularly and check for lubrication.
- Replace broken Chain elements immediately.
- Lubricate between all inner and outer Chain plates, and Chain drive components.
- Apply lubrication evenly to all parts of the Chain.
- Chains unused for a long time should be cleaned and lubricated regularly.
- Lubricate the Chains based on the environment tables below.

Windy and dusty work environment		
Temperature	Oil	Frequency of Lubrication
-10° to 0°C	Machine Oil for Chain Lubrication 20#	Once per week.
0° to 40 °C	Machine Oil for Chain Lubrication 30#	
40° to 50°C	Machine Oil for Chain Lubrication 40#	
50° to 60°C	Machine Oil for Chain Lubrication 50#	

Windless and clean work environment		
Temperature	Oil	Frequency of Lubrication
-10° to 0°C	SR4020	Once every two months.
0° to 40 °C	SR4020	
40° to 50°C	TX8R	
50° to 60°C	TX8R	

Important: In working environments with high humidity, rust-proof treatment and higher frequency of lubrication is required, at least once per month minimum.

To clean and protect the Lift:

 **WARNING** Prior to cleaning under the Lift Platform, verify the Platform is secured on its Safety Locks or resting on the ground and power is locked out to prevent movement.

- Regularly clean the Lift Platform and under the Platform using a broom or vacuum.

-
- In winter, snow, ice, road salt and dirt deposits must be removed from under the Lift Platform and from the Lift Platform itself. This may be required several times a month depending on weather conditions.
 - Condensation is to be removed, in particular condensation under the Lift Platform.
 - At the end of the winter season, carry out a thorough cleaning of the entire Platform with broom, or vacuum. Do **not** use high pressure cleaning equipment.
 - Lift Posts, Post Bases and mounting are to be cleaned of dirt deposits at least twice yearly.
 - Galvanized Lift Platform Plates may develop a white haze due to damp conditions or poor ventilation. This white haze (zinc oxide) does not damage the Plates.
 - Check for rust at every cleaning of the Lift. Rust may be caused by mechanical wear, road salt or neglect. Lightly rub the area with a medium fine Steel Wool. Do not use a wire brush. Paint treated surfaces.
 - Check fasteners for tightness and rust at each cleaning of the Lift. Fasteners with rust should be cleaned with a brass brush using light pressure, clean then apply a spray-on protective wax.
 - Damage to powder coated surfaces are to be treated as soon as possible to prevent infiltration of oxidation under the powder coated surface. Lightly rub the damaged area with emery cloth (120 grit) or a brass brush. Clean, then degrease the damaged area. Apply touch-up paint to protect and seal the area.

Troubleshooting

This section describes how to troubleshoot your Lift.

Note: If your Lift is not functioning correctly, you must take it out of service until it is fixed.

Important: All repair work **must** be done by qualified personnel. If you are having issues, take the Lift out of service, then contact your dealer, visit bendpak.com/support, email support@bendpak.com, or call **(800) 253-2363**, follow the prompts to reach support.

 **WARNING** The Lift uses electrical energy; if your organization has Lockout/Tagout policies, implement them **before** performing any maintenance or troubleshooting.

Problem	Possible cause	Solution
Motor runs, but Lift Platform does not move or moves very slowly.	The motor is rotating in the wrong direction.	3-Phase power only. Reconnect main power supply by swapping two power leads to reverse the magnetic field.
	Insufficient or no Hydraulic Oil in the reservoir.	Refill Hydraulic Oil reservoir.
	Hydraulic Oil intake broken.	Repair/Replace oil intake pipe.
	Broken Coupling.	Replace coupling.
	Blocked inlet Filter.	Clean or replace Oil Filter
	Solenoid Valve element is blocked.	Clean or replace Solenoid Valve.
	Solenoid Valve Seal failure.	Clean or replace Solenoid Valve.
	Hydraulic Gear Pump is worn or broken.	Replace Hydraulic Power Unit.
	Cylinder worn or damaged.	Replace the Cylinder.
	Hydraulic Fluid dirty.	Replace the Hydraulic Oil.
	Oil temperature in Reservoir is out of the normal range.	Allow Hydraulic Oil to cool to room temperature.

Power Unit

Problem	Possible cause	Solution
Pressure cannot be maintained after Platform is Lifted.	Solenoid Valve element is blocked.	Clean or replace Solenoid valve.
	Outlet fitting is not fastened, or seal is damaged.	Reattach Outlet Pipe or replace seal.
	Dirty Hydraulic Oil.	Replace Hydraulic Oil.
Cylinder retracts slowly when lowering.	Throttle Valve is not adjusted.	Adjust Throttle Valve.
	Throttle valve is blocked.	Clean or replace Valve.
	Solenoid Valve is blocked.	Clean or replace Valve.
Cylinder does not retract at all when lowering.	Lowering Valve blocked.	Clean or replace valve.
	Lowering solenoid is inoperative or supply voltage is too low.	Replace Solenoid Coil or supply correct voltage to the coil.
	Cylinder worn or broken.	Replace the Cylinder.
Lift is too loud, or Lift is making an abnormal noise when Power Unit is on.	Motor is inoperative.	Replace motor.
	Low Hydraulic Fluid allows air into pump and system.	Refill Reservoir. Run the Lift up and down several times to bleed air out of the system.
	Pressure Relief Valve is triggered.	Remove excess weight.
	Inlet Filter is blocked.	Clean or replace filter.
	Hydraulic Oil is dirty.	Replace Hydraulic Oil.
	Pressure relief valve is inoperative.	Replace Pressure Relief Valve.
Motor does not function.	Input Voltage too low.	Correct the low voltage.
	Voltage drop due to wrong wire gauge for distance.	Replace the wire with the correct wire gauge for the distance.
	Starting Capacitor inoperative.	Replace starter Capacitor.

Hydraulic Cylinder

Problem	Possible cause	Solution
Cylinder moves in short jerks.	Air in the Hydraulic System.	Run the Lift up and down several times to bleed the air from the system.
	Friction due to lack of lubrication or misalignment.	Lubricate the Lift.
	Poor seal alignment on Cylinder Rod.	Align Cylinder Rod.
	Severe leaking of the Cylinder.	Replace Cylinder Seals.
	Friction resistance due to dirty Hydraulic Fluid.	Clean Hydraulic System Elements and replace Hydraulic Oil and Filter.
Pressure shock	One-Way valve or throttle valve failure in cushion device	Repair one-Way valve/throttle valve.

Problem	Possible cause	Solution
Insufficient thrust or low speed.	Oversize/undersize fit clearance between bore and Cylinder Rod, broken or incorrect seals.	Repair/replace parts with correct size and accuracy. Seals to be reassembled, adjusted, or replaced.
	Severe leaking of the Cylinder.	Replace Cylinder Seals.
	Bent Cylinder Rod.	Straighten Rod or replace Cylinder.
	Poor assembly of parts resulting in loss of concentricity or excessive friction on one side of the Lift.	Repair/replace parts and reassemble.
	Damaged Cylinder Bore results in blocked Rod	Hone to repair Cylinder bore.
	Damaged Cylinder Bore results in blocked Rod	Hone to repair Cylinder bore.
	Contaminated Hydraulic Fluid results in block Cylinder Rod.	Clean Hydraulic Circuit and replace Hydraulic Oil.
Insufficient thrust or low speed. (Continued)	Hydraulic Oil Temperature too high causing Seals to leak.	Search for cause of excessive temperature.
	Insufficient Hydraulic Oil in the Reservoir.	Fill Hydraulic Fluid Reservoir.
	Excessive Oil pressure in return line.	Increase diameter of return line, reduce back pressure valve.
	Pressure Relief Valve failure.	Replace Pressure Relief Valve.
Leaking Hydraulic Fluid	Galling, scratches, or damaged seals.	Replace Seal(s).
	Seal incorrectly installed.	Replace Seal and install in the correct direction.
	Longitudinal scratches or grooves between moving parts inside the Cylinder body.	Repair or replace the Cylinder parts or the complete Cylinder.
	Vibration of inlet and outlet Hydraulic Oil pipes result in loosening of connection points.	Tighten the inlet and outlet pipes or change connection type.
Noise	Air in the Hydraulic System.	Eliminate leaks and bleed the system of air by raising and lowering the Lift several times.
	Clearances between relative moving/sliding parts is too tight.	Disassemble and re-assemble with proper clearances.
	Excessive friction and/or lack of lubrication on sliding seal surface.	Replace Cylinder Seals.
	Deformed or damaged Guiding Support Ring.	Support Ring to be repaired or replaced.

If you continue to have issues with your Lift, take it out of service, then contact your dealer, go to [bendpak.com/support](https://www.bendpak.com/support), email support@bendpak.com, or call **(800) 253-2363**, follow the prompts to reach support.

Lift and Hydraulic Fluid Disposal - End of Service Life

Once the Lift has reached the end of its service life it must be disposed of properly. Metal recyclers will be able to advise on methods and costs to remove the Lift and will *reuse* the materials, diverting them from landfills. The best option is to contact a metal recycling center and discuss the size and weight of the Lift to determine if the facility can deconstruct and recover the usable components and metals.

The Hydraulic Cylinders, Hoses, Fittings, and the Power Unit itself must be disposed of in accordance with current national, state, and local regulations governing the use and disposal of hazardous materials. These components and any used Hydraulic Fluid **must not** be disposed of by dropping it into the trash or dumping it into the street. The Hydraulic Fluid contains toxic ingredients that are harmful to the environment.

These components and the Hydraulic Fluid are required to be recycled or must be delivered to a hazardous waste collection facility.

If you have large amounts of Hydraulic Fluid, consider contacting a commercial waste disposal company. In all cases, the best approach is to find an appropriate facility and contact them — in advance — to ask them: what kinds of fluids and materials they accept, what kind of containers it must be in, what hours they are open, their location, and any other information specific to their facility.

If you are unable to find an appropriate facility, the website [earth911.com](https://www.earth911.com) has resources that may be of help.

Multiple Lift Installations

Multiple Lifts may be installed side-by-side, sharing a Post. The first Lift requires the complete Lift with two Posts and is designated Unit A (5175427). Additional Lifts are designated Unit B and only require one additional Lift Post (5175439). By sharing a Post, the Lifts cover a smaller area, are structurally stronger and reduce cost. Each lift requires its own Power Unit, electrical supply, and control. On installations with multiple Lifts, the Platforms operate independently.

Space Requirements – PL-6000DC Multiple Lift Installations

Typical spacing required for two PL-6000DC Lifts sharing one Post as detailed below. *Each Lift requires its own Power Unit and Electrical supply.*

Unit A: PL-6000DC (5175427) 6,000 lb. Capacity/Two-Post Parking Lift/Shared Columns with Power Unit.

Unit B: PL-6000DC-Add-On (5175439) Shared Column Add-On Platform and Column Set with Power Unit.

Refer to the figure below.

Top View PL-6000DC

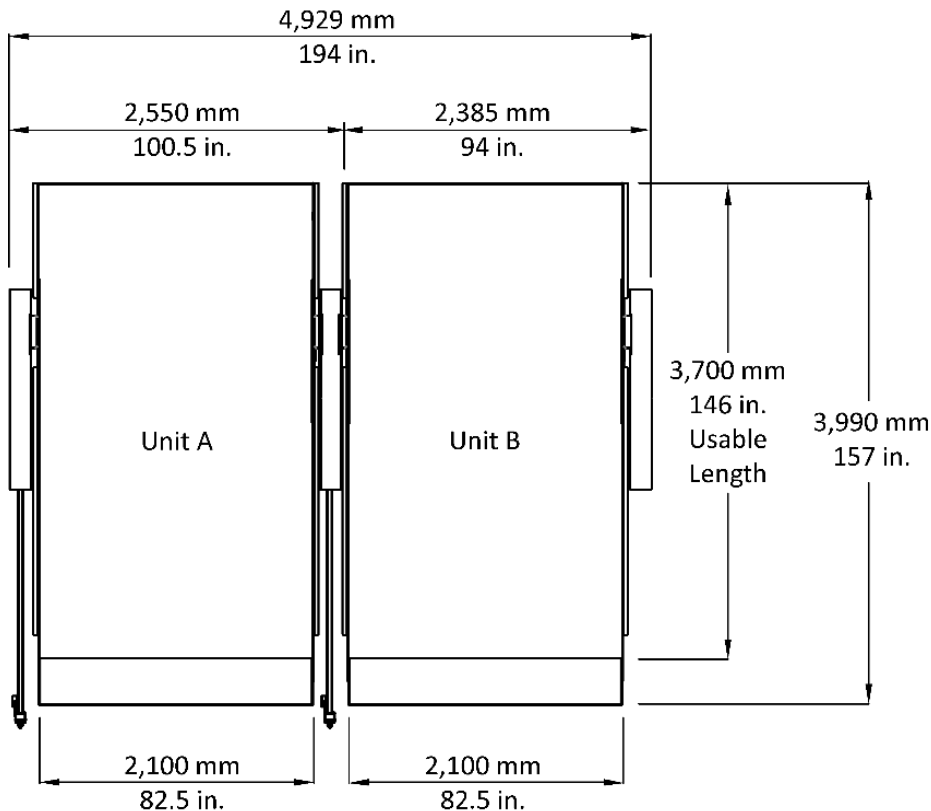

Drawing not to scale.

Typical spacing required for three PL-6000DC Lifts sharing two Posts.

Top View PL-6000DC

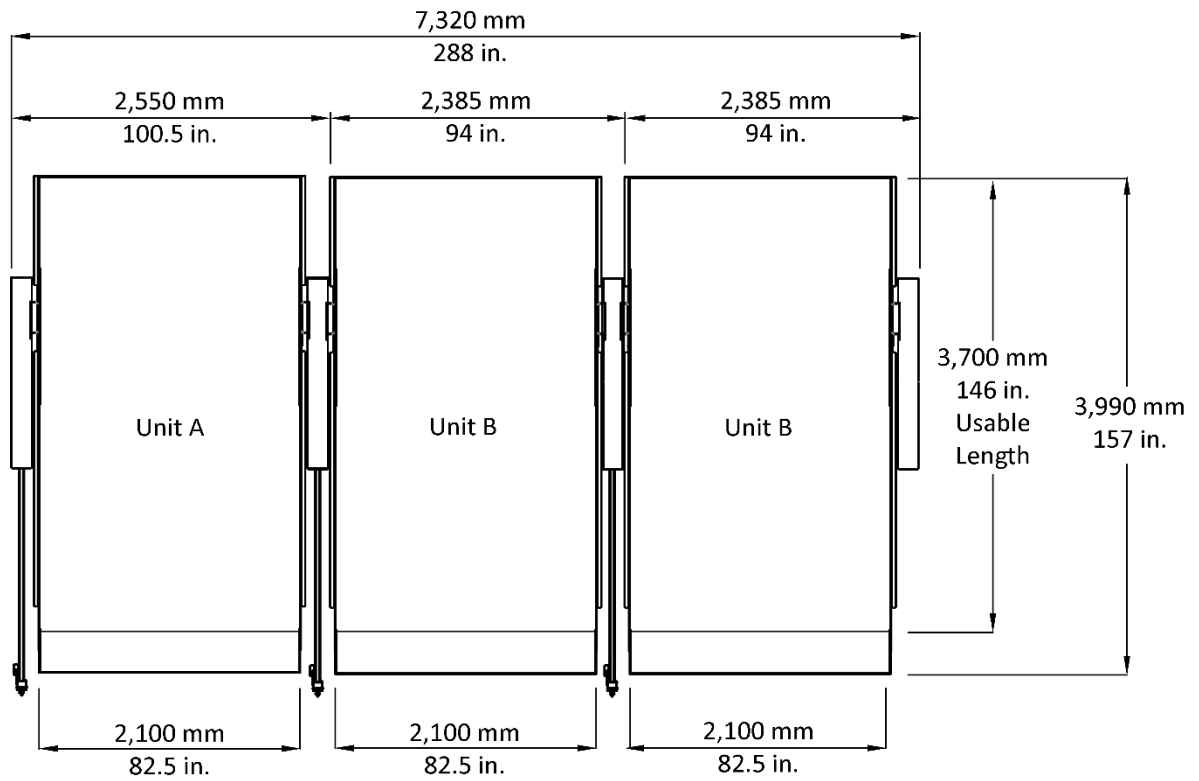

Drawing not to scale.

Space Requirements – PL-6000DCX Multiple Lift Installations

Typical spacing required for two PL-6000DCX Lifts sharing one Post as detailed below. *Each Lift requires its own Power Unit and Electrical supply.*

Unit A: PL-6000DCX (5175625) 6,000 lb. Capacity/Two-Post Parking Lift/Shared Columns with Power Unit.

Unit B: PL-6000DCX-Add-On (5175643) Shared Column Add-On Platform and Column Set with Power Unit.

Refer to the figure below.

Top View PL-6000DCX

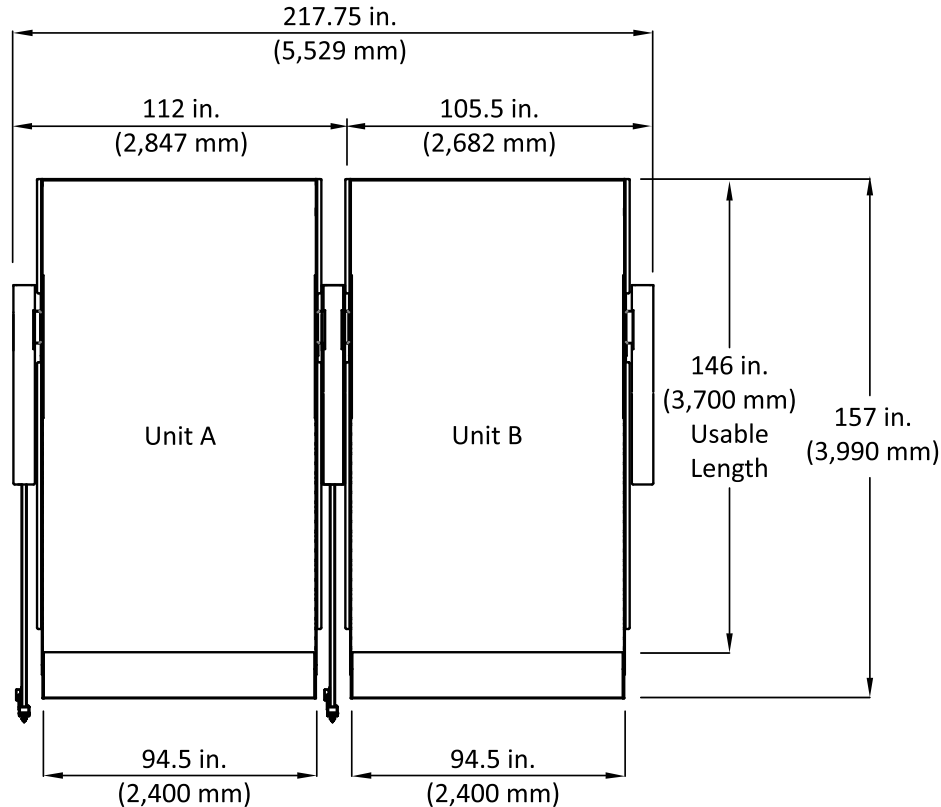

Drawing not to scale.

Typical spacing required for three PL-6000DCX Lifts sharing two Posts.

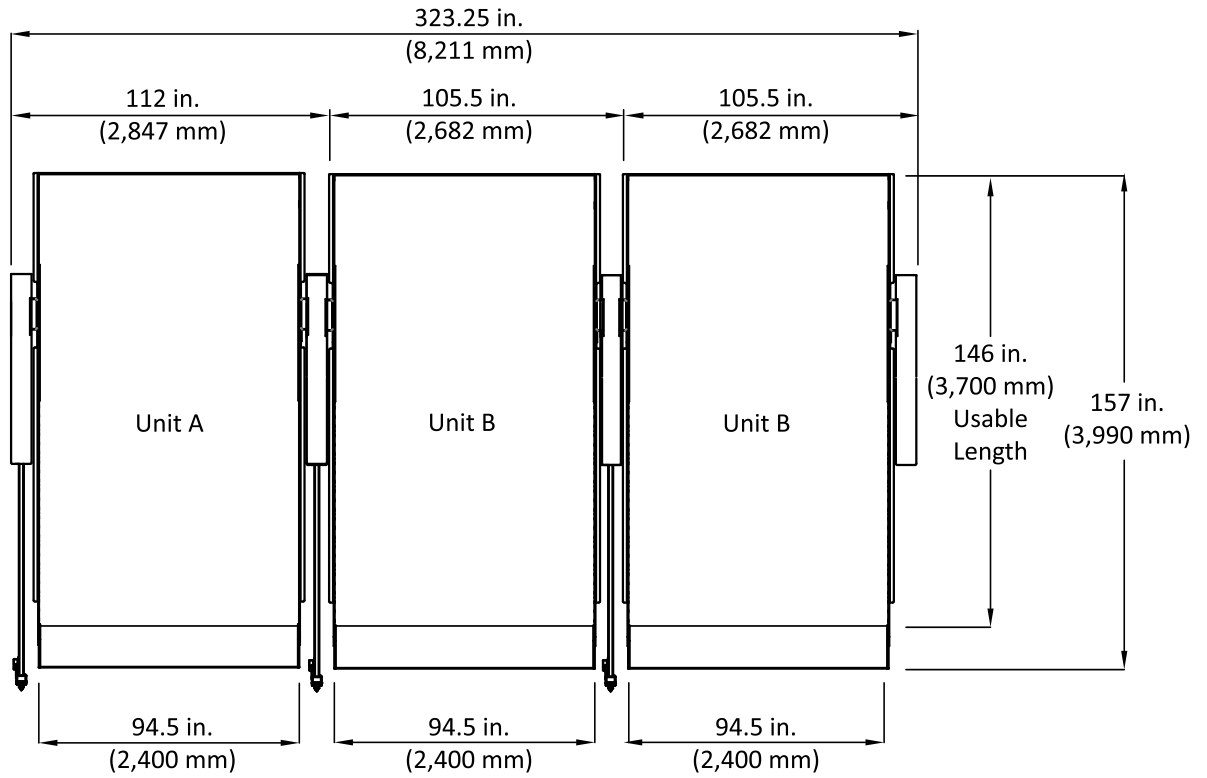

Drawing not to scale.

Wiring Diagrams

⚠ WARNING All electrical work (including the installation of thermal and electrical disconnects) **must** be performed by a licensed, Electrician in accordance with all applicable local and national electrical codes. **Damage caused by improper electrical installation may void your warranty.**

Junction Box Controls Wiring Diagram Power Unit 5585152

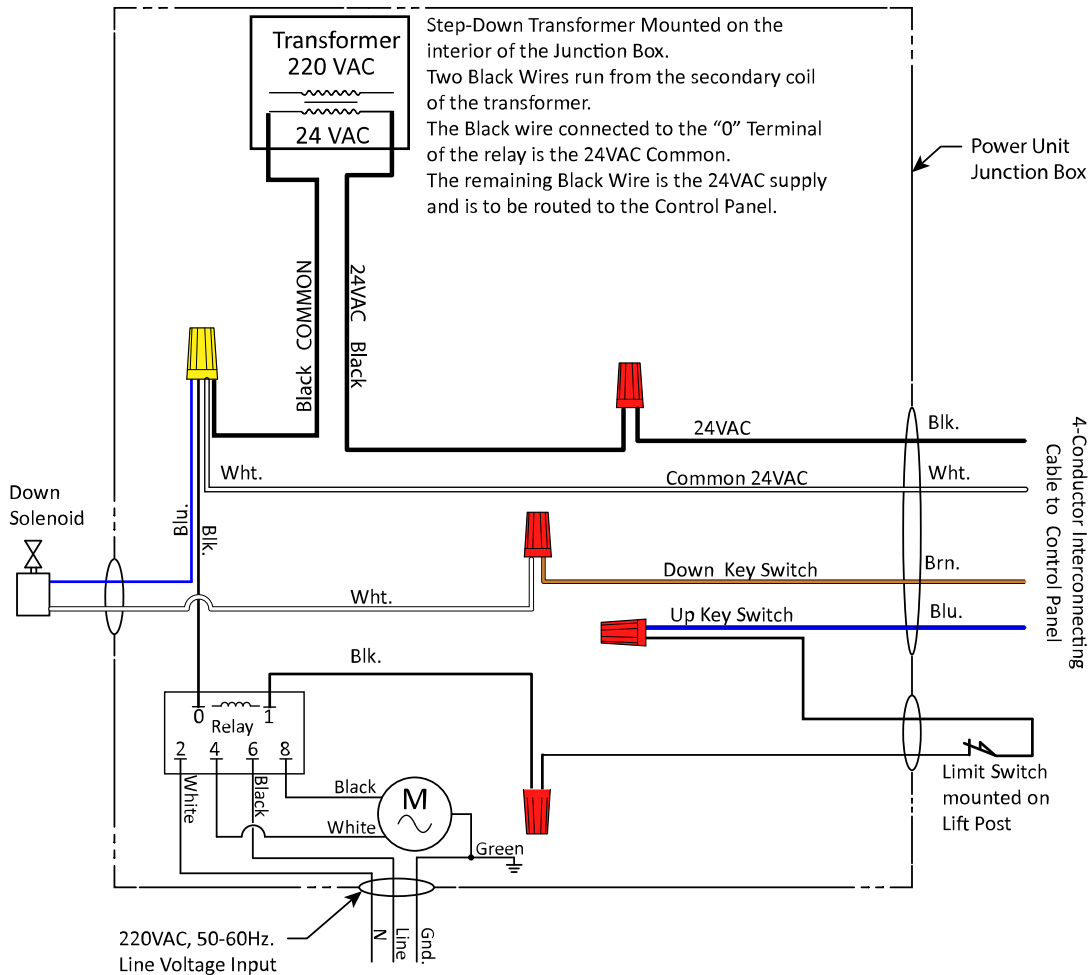

Control Panel Wiring Diagram

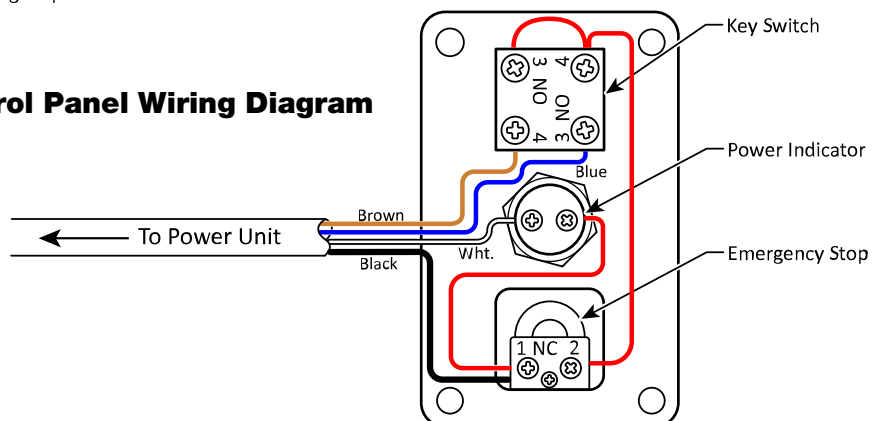

Drawing not to scale. Control Panel wire side view.

Schematic 220 VAC, 60 Hz., 1 Phase, Power Unit 5585152:

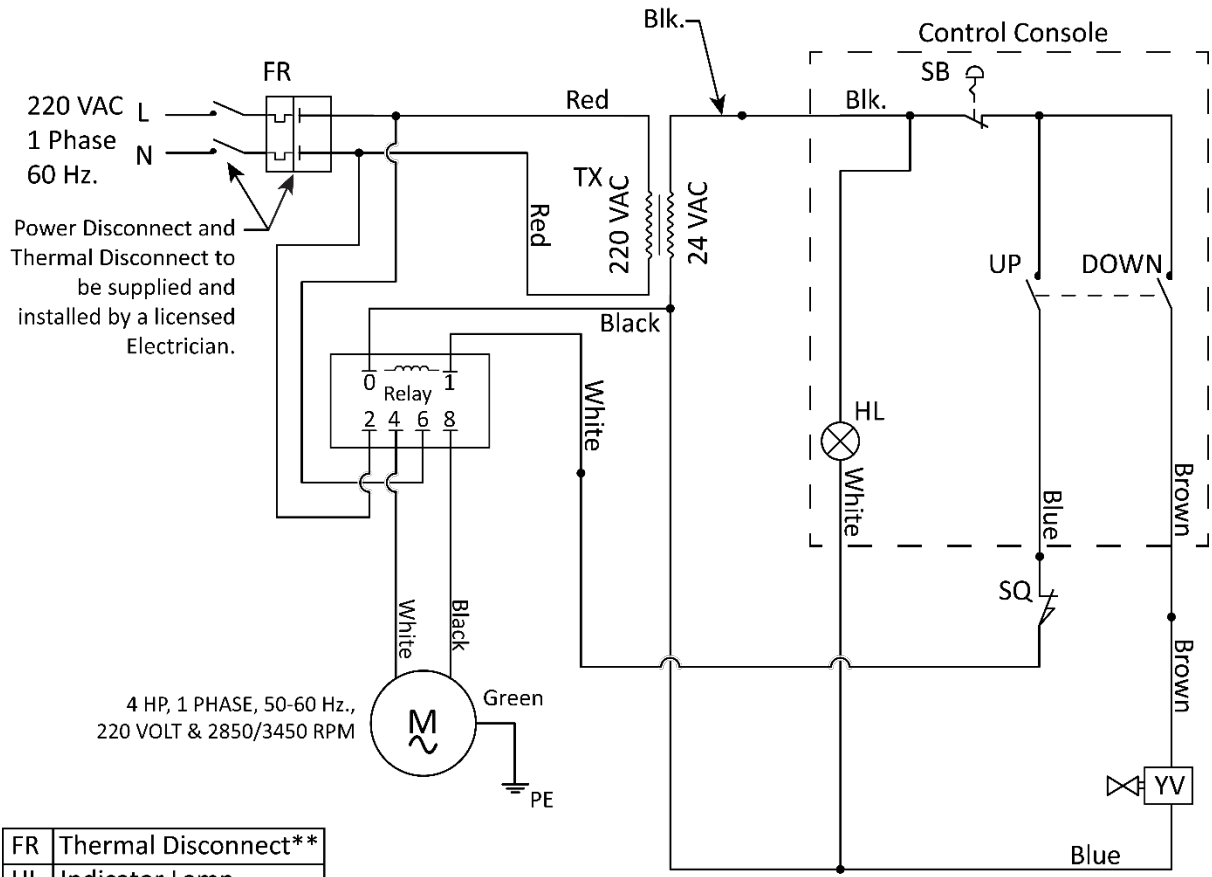

FR	Thermal Disconnect**
HL	Indicator Lamp
SB	Emergency Stop
SQ	Limit Switch*
YV	Solenoid Coil
TX	Transformer

*Limit switch is supplied with the Lift, but must be connected to the Power Unit by a licensed Electrician.

**Power and Thermal Disconnect must be supplied and installed by a licensed electrician, in accordance with all local, state and national electrical codes.

Junction Box Controls Wiring Diagram Power Unit 5585420

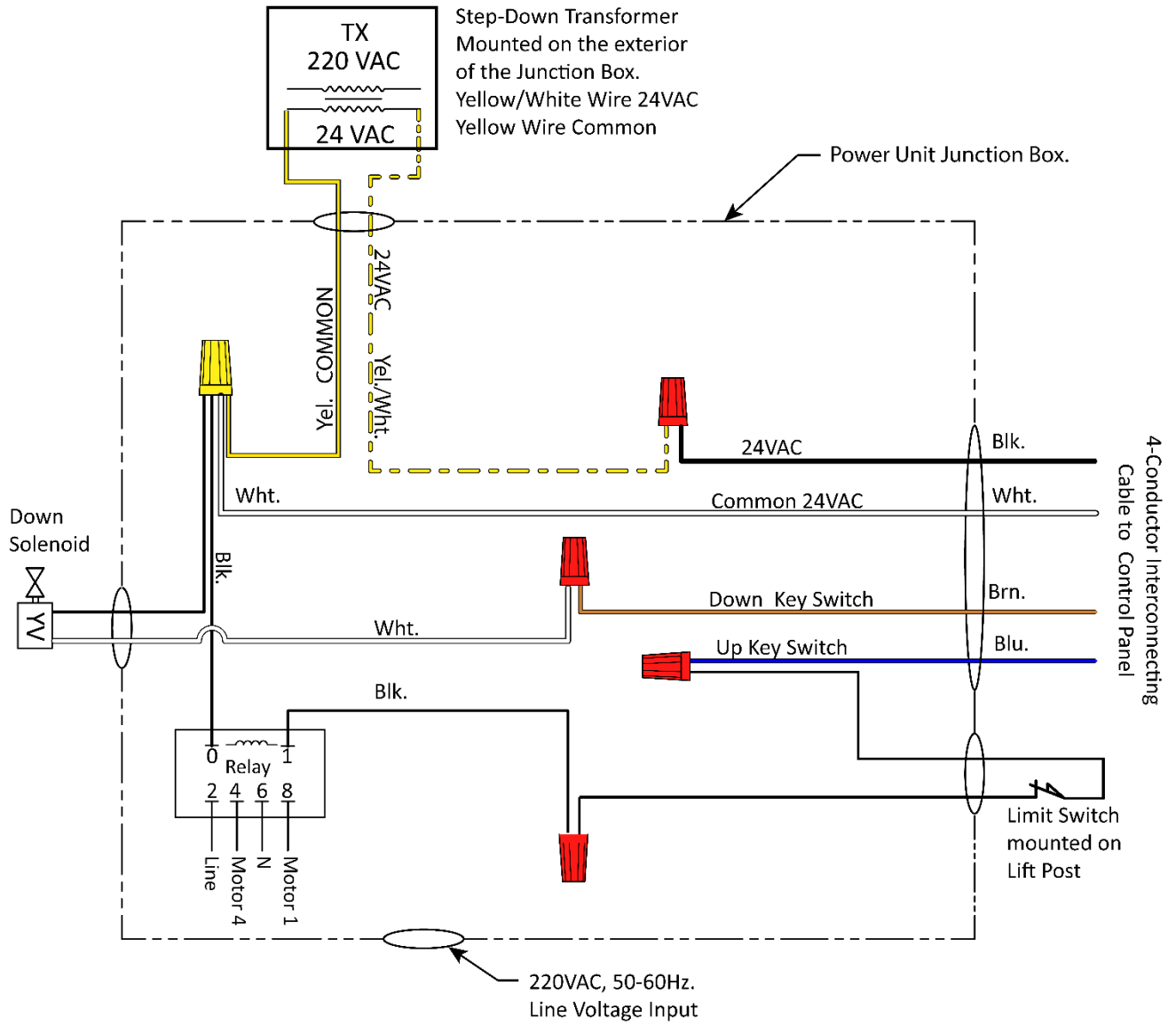

Control Panel Wiring Diagram

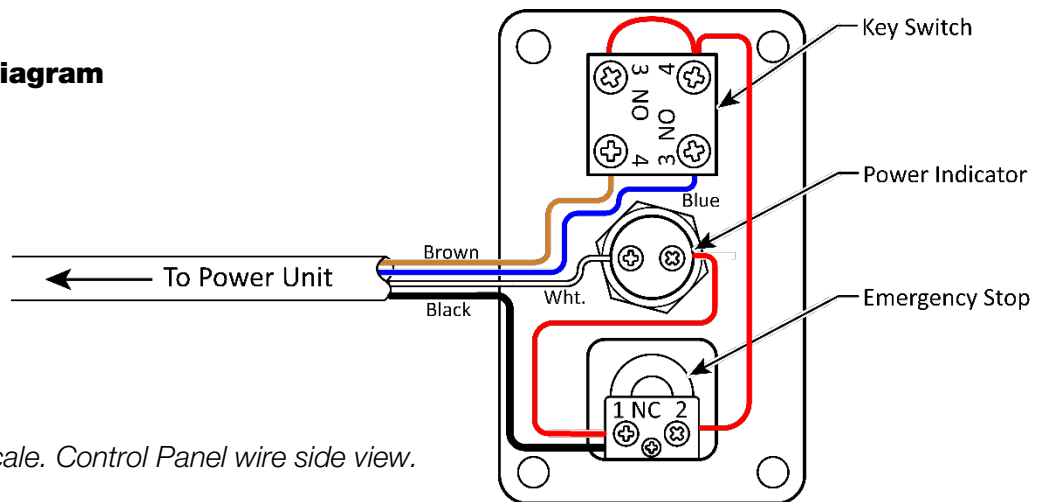

Drawing not to scale. Control Panel wire side view.

Schematic 208 - 230 VAC 1 Phase (Power Units 5585184 and 5585420):

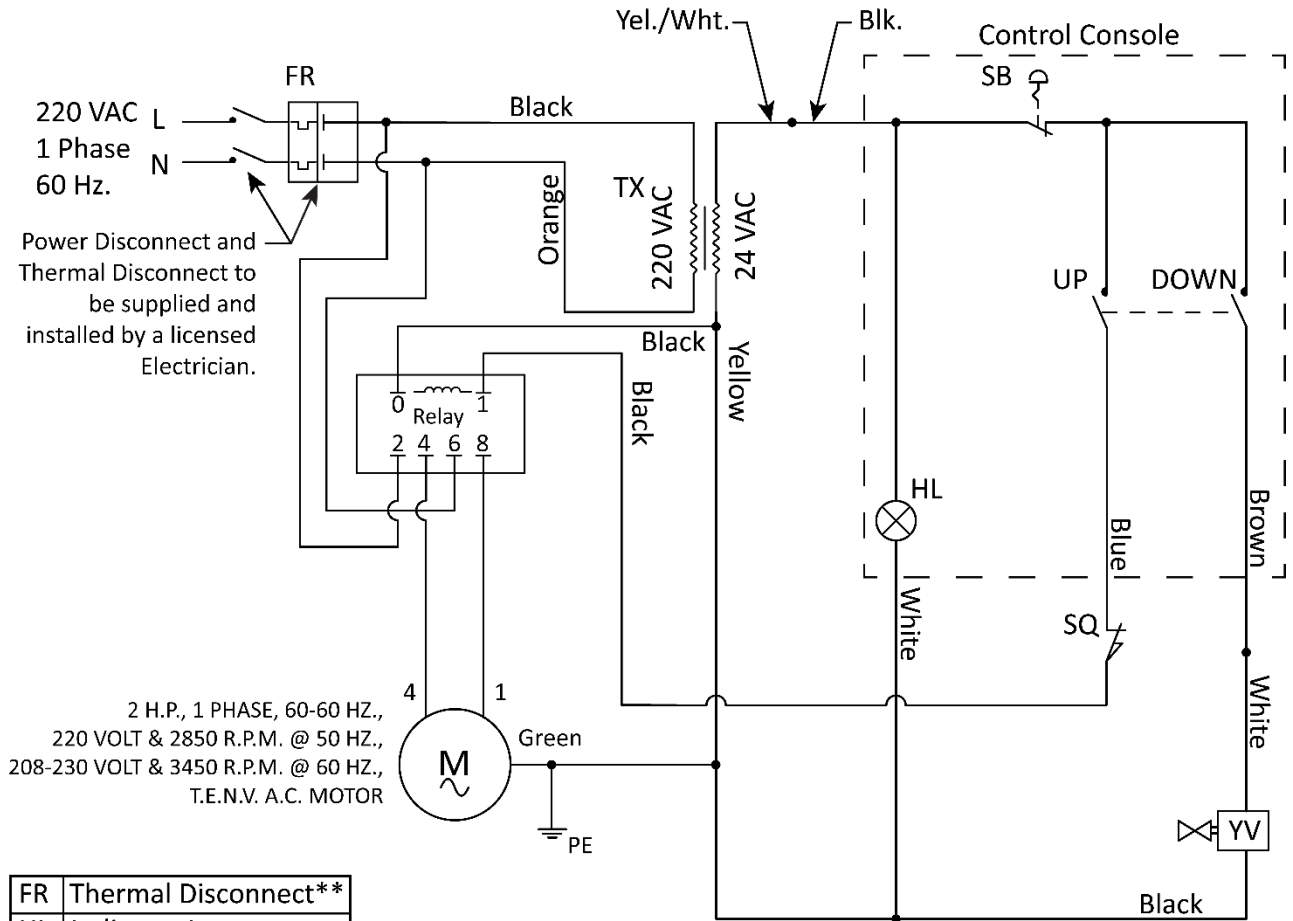

FR	Thermal Disconnect**
HL	Indicator Lamp
SB	Emergency Stop
SQ	Limit Switch*
YV	Solenoid Coil
TX	Transformer

*Limit switch is supplied with the Lift, but must be connected to the Power Unit by a licensed Electrician.

**Power and Thermal Disconnect must be supplied and installed by a licensed electrician, in accordance with all local, state and national electrical codes.

Junction Box Controls Wiring Diagram Power Unit 5585023

⚠ WARNING All electrical work (including the installation of thermal and electrical disconnects) **must** be performed by a licensed, Electrician in accordance with all applicable local and national electrical codes. **Damage caused by improper electrical installation may void your warranty.**

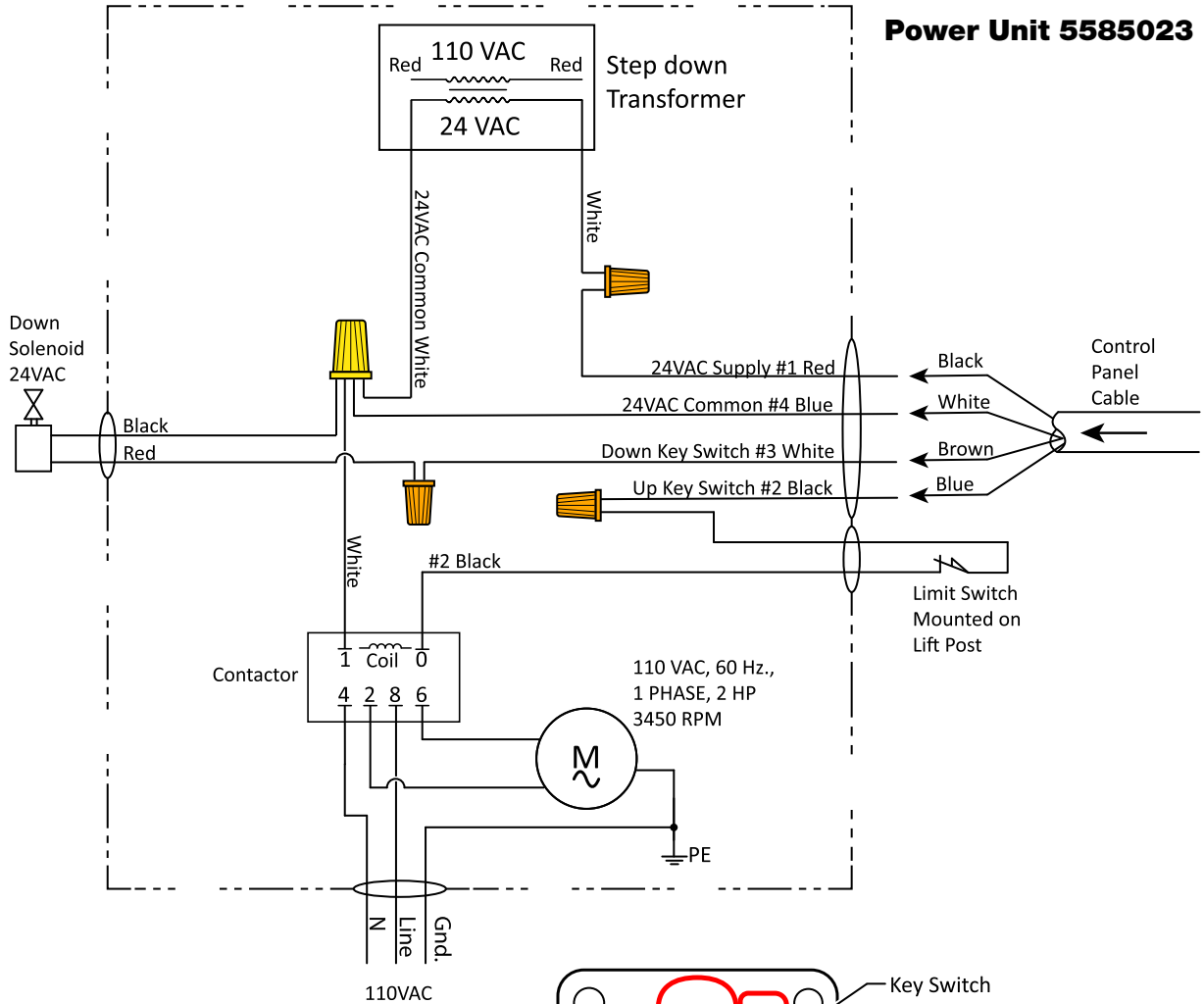

Control Panel Wiring Diagram

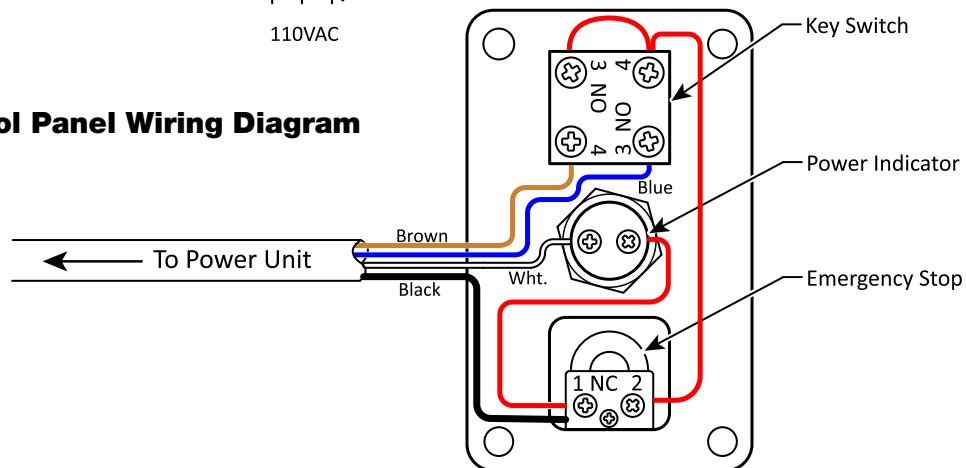

Drawing not to scale. Control Panel wire side view.

Schematic 110 VAC 1 Phase (Power Unit 5585023)

110 VAC, 60/50 Hz. 1 Phase (5585023)

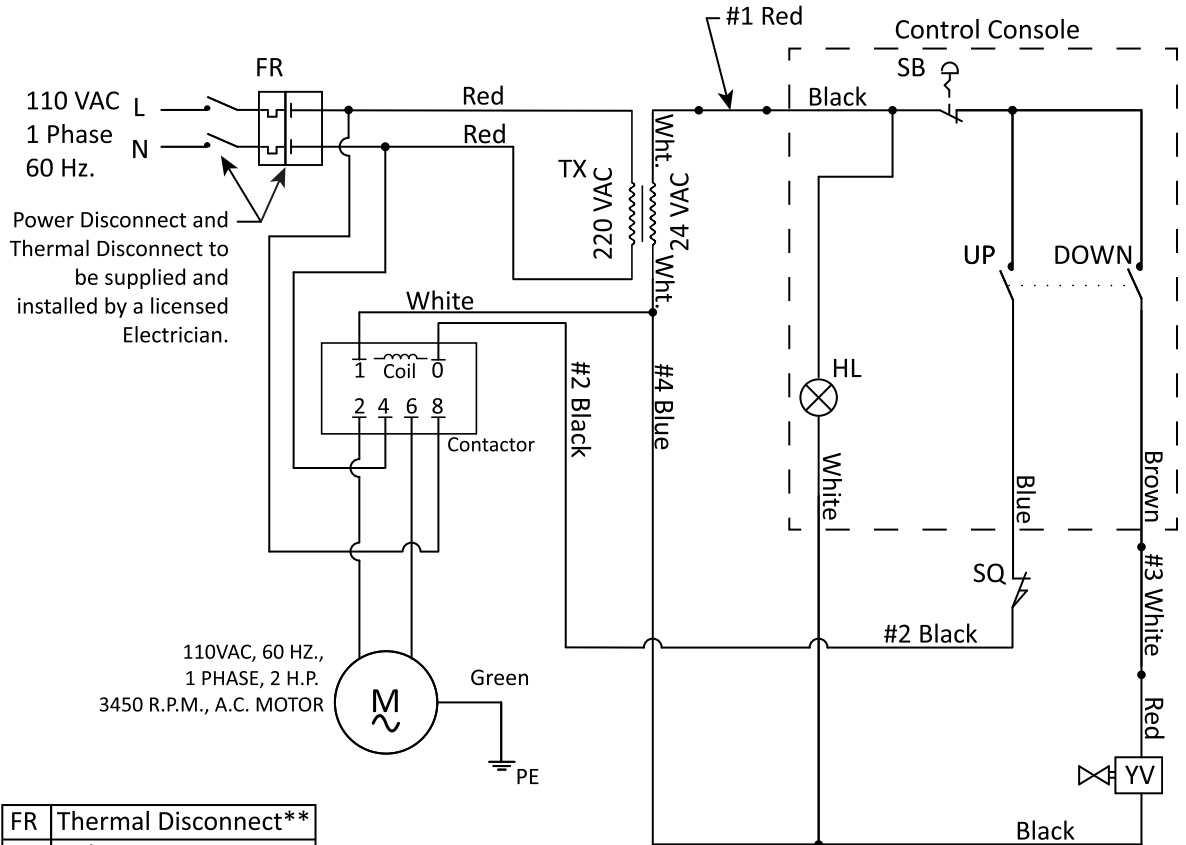

FR	Thermal Disconnect**
HL	Indicator Lamp
SB	Emergency Stop
SQ	Limit Switch*
YV	Solenoid Coil
TX	Transformer

*Limit switch is supplied with the Lift, but must be connected to the Power Unit by a licensed Electrician.

**Power and Thermal Disconnect must be supplied and installed by a licensed electrician, in accordance with all local, state and national electrical codes.

Labels

FRONT

**PARKING LIFT
OPERATION WARNINGS**

Read the entire operation manual, and operation instructions shown on the reverse side of this placard before operating this parking lift. If any questions arise as to the safety or operation of this lift contact your property manager, building engineer, local parking lift dealer or call BendPak at 1 (800) 833-8970. Always use caution when operating this lift. Never allow children or persons under the influence of drugs or alcohol to use this lift. Serious injury, property damage, and/or death can occur if this lift is improperly used.

⚠ WARNING

ALWAYS double-check clearance BEFORE driving vehicle under lift platform.

⚠ WARNING

Never place any object or any part of your body on the Lift Posts or any other part of the lift during operation. Serious injury or death can occur.

⚠ WARNING

- Read the entire operation manual before operating this parking lift.
- **NEVER** leave the lift unattended when it is partially raised or lowered.
- **DO NOT** raise the lift platform when the lift is empty. The lifts are designed to be lowered with the weight of a vehicle on the platform. Empty lifts will take much longer to lower.
- Always use caution when operating this lift.
- Serious injury, property damage, and/or death can occur if this lift is improperly used.
- Keep hands and feet clear. Remove hands and feet from any moving parts. Keep feet clear of lift when lowering. Avoid pinch points.
- Only trained operators should operate this lift. All non-trained personnel should be kept away from work area. Never let non-trained personnel come in contact with, or operate lift.
- Guard against electric shock. This lift must be grounded while in use to protect the operator from electric shock.
- Risk of explosion. This lift has internal arcing or sparking parts which should not be exposed to flammable vapors.
- Maintain lift with care. Keep lift clean for better and safe performance. Follow manual for proper lubrication and maintenance instructions. Keep control handles and/or buttons dry, clean and free from grease and oil.
- Stay alert - watch what you are doing. Use common sense and always be aware.
- Check for damaged parts. Check for alignment of moving parts, breakage of parts or any condition that may affect safe operation of the lift. Do not use lift if any component is broken or damaged.
- Never remove safety related components from the lift. Do not use lift if safety related components are damaged or missing.

IMPORTANT NOTE

The custom lock-setting of the lift determines the height of the vehicles that can be safely parked underneath the lift. Make sure that you are using only vehicles that are of the proper height for the custom lock-setting. If the setting of your lift needs to be changed, contact your parking lift dealer.

BACK

**PARKING LIFT
OPERATION INSTRUCTIONS**

Read the entire operation manual and warning instructions shown on the reverse side of this placard before operating this parking lift.

PRE-LIFTING STAGE

1. Review the Operating Manual and all safety labels **BEFORE** using the Lift.
2. Inspect the Lift before use. If worn, broken or missing parts are found, do **NOT** use. Take the Lift out of service.
3. Drive the vehicle onto the Lift platform. Vehicle should be centered on the platform, and may be driven in nose first or backed in.
4. Drive until the vehicle's tire rest against the forward wheel stop.
5. Place the vehicle's gear selector in park, turn off the engine, and engage the safety brake. For manual transmissions, shift to first gear, turn off the engine and set the safety brake.
6. Check the front of the Lift to make sure that the vehicle's tires are securely set against the wheel stop.
7. Walk around the Lift to ensure no obstructions will interfere with the vehicle being lifted.
8. Position yourself in front of the Lift within reach of the operator control console.

LIFTING STAGE

1. Once all precautions above are followed, check around and above the Lift to ensure that no objects are obstructing the platform, and that no persons (except the Lift operator) are within 10 feet.
2. To raise the Lift Platform to the desired height, turn the operator switch on the control console to the **LEFT** and hold.
3. **ALWAYS** raise the platform until it reaches its top limit switch lock position.
4. If a low ceiling is overhead, be careful when lifting. **NEVER** allow the top of the vehicle to come in contact with any overhead structure or object.
5. Once the top position is reached, release the operator switch to its neutral position.
6. To lower the vehicle onto the Lift's mechanical locks, turn and hold the operator switch to the **RIGHT**.
7. **ALWAYS** walk around the Lift to inspect the Lift and the vehicle. **NEVER** walk under the raised platform.

PLACEMENT OF LOWER VEHICLE

1. Once all precautions of the Pre-Lifting and Lifting Stage have been followed, drive the lower vehicle under the Lift platform until the tires reach the front wheel bar, or to the location where the car is properly positioned under the Lift to allow clearance for the doors and mirrors.
2. Place the vehicle's gear selector in Park, turn off vehicle's engine, and engage the safety brake. For manual transmissions, shift to first gear, turn off the engine and set the safety brake.
3. When exiting the vehicle use care to not damage the vehicle's doors/mirrors against the sides of the Lift. Watch your head so as to not hit the underside or corners of the Lift Platform.

REMOVAL OF LOWER VEHICLE

Verify the path is clear, then carefully drive the vehicle out from underneath the Lift Platform.

LOWERING THE LIFT

1. Walk around the Lift to make sure nothing is below or near the Lift Platform's entire lower area to prepare for descent.
2. Verify that no person (except the Lift operator) is within 10 feet of the Lift area.
3. Turn and hold the operator switch to the **LEFT** to **RAISE** the Lift approximately two inches (or enough to allow release of the mechanical locks) and then release the operator switch to its neutral position.
4. Pull back and hold the lock release safety lever located below the control console, turn and hold the operator switch to the **RIGHT** position to **LOWER** the Lift Platform.
5. When lowering the Lift **ALWAYS** be watchful for objects, persons or animals that may wander under the Lift platform during operation. Cease operation if the Lift area becomes obstructed.
6. **KEEP HANDS AND FEET CLEAR OF ALL MOVING PARTS AND PINCH POINTS.**
7. Release the lock release safety lever and operator switch upon full descent of the Lift Platform.
8. Verify the path is clear; then carefully drive the vehicle out of the Lift.



16 030007

B

DANGER

KEEP HANDS AND FEET
CLEAR AT ALL TIMES FROM
MOVING MACHINERY

GARDEZ LES MAINS ET LES PIEDS
À DISTANCE À TOUT MOMENT DES
MACHINES EN MOUVEMENT



C BENDPAK

BP

ABOVE-GROUND LIFTS

EP BendPak.
 1645 Lemonwood Drive
 Santa Paula, CA 93060
 U.S.A.
 (805) 933-9970
 www.bendpak.com



PN 50043

D

⚠ DANGER

THE MAXIMUM LIFTING CAPACITY FOR THIS LIFT IS DESCRIBED BELOW

Maximum Lifting Capacity 6,000 lbs. / 2,722 kg
Max. Lifting Cap. / Front of Lift Center 3,000 lbs. / 1,361 kg
Max. Lifting Cap. / Rear of Lift Center 3,000 lbs. / 1,361 kg

Exceeding the weight capacity of this lift can damage lift and/or property and may cause personal harm, injury or death to operators and/or bystanders. All vehicles **MUST** be positioned on lift with **CENTER OF GRAVITY** midway between adapters and/or centered on runways. Damage to lift due to overloading or misuse is **NOT** covered under warranty.

LA CAPACITÉ DE LEVAGE MAXIMUM POUR CE LEVAGE EST DÉCRIT CI-DESSOUS

Capacité de Levage Maximale 6,000 lbs. / 2,722 kg
Max. Capuchon De Levage. / Avant du centre de relèvement 3,000 lbs. / 1,361 kg
Max. Capuchon De Levage. / Arrière du centre de levage 3,000 lbs. / 1,361 kg

Le dépassement de la capacité de poids de cet élévateur peut endommager l'ascenseur et / ou les biens et peut causer des dommages corporels, des blessures voire la mort aux opérateurs et / ou aux passants. Tous les véhicules **DOIVENT** être placés sur l'élévateur avec le **CENTRE DE GRAVITÉ** à mi-chemin entre les adaptateurs et / ou au centre des pistes. Dommages à soulever dus à la surcharge ou une mauvaise utilisation **N'EST PAS** couverte par la garantie.

PN 50043B

G



⚠ WARNING

SLIPPERY WHEN WET OR ICY

Use caution when driving onto wet or icy drive-up ramps and platforms. **DO NOT** walk on lift surfaces that are wet or icy.



⚠ AVERTISSEMENT

GLISSANT LORSQU'IL EST MOUILLÉ OU GLACÉ

Soyez prudent lorsque vous conduisez sur des rampes d'accès mouillées ou verglacées et les plateformes. **NE PAS** marcher sur des surfaces de levage humides ou glacées.

PN 50043C

H

CALIFORNIA PROPOSITION 65

⚠ WARNING ⚠

WARNING: This product contains chemicals known to the State of California to cause cancer and birth defects or other reproductive harm.

ADVERTENCIA: Este producto contiene sustancias químicas reconocidas por el estado de California como causantes de cáncer y defectos de nacimiento u otros daños reproductivos.

For more information visit:
www.P65Warnings.ca.gov

E

EP BendPak. Santa Paula, CA USA
www.bendpak.com

MODEL NUMBER _____

DESCRIPTION _____

LIFT CAPACITY _____ DATE CODE _____

VOLTAGE SERIAL NUMBER

110-120V, 50-60 Hz, 1 Ph _____

208-240V, 50-60 Hz, 1 Ph _____

380-415V, 50-60 Hz, 3 Ph _____

208-440V, 50-60 Hz, 3 Ph _____

UPC _____

⚠ DANGER!
 Disconnect Power Before Servicing

MADE IN CHINA WARRANTY VOID IF DATA PLATE IS REMOVED PN 50043D

I

⚠ WARNING



WARNING! Electrical Shock Hazard.
 DO NOT remove cover. Refer servicing to qualified service personnel.

WARNING! Read all the instructions before operating this equipment.

CAUTION! For installation in non-hazardous locations only.

F

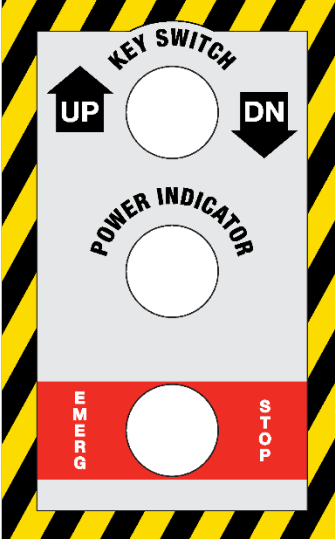

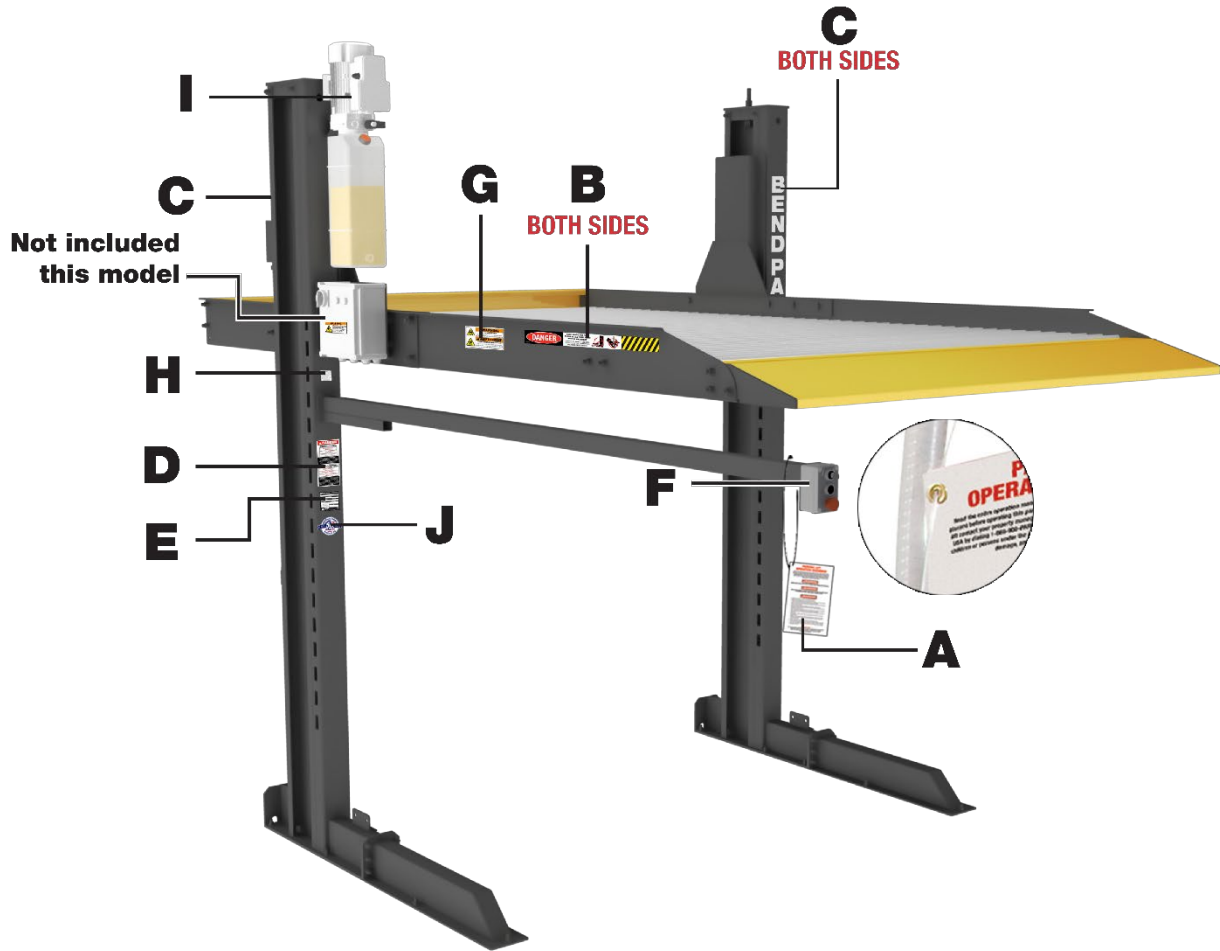
Parts Drawings

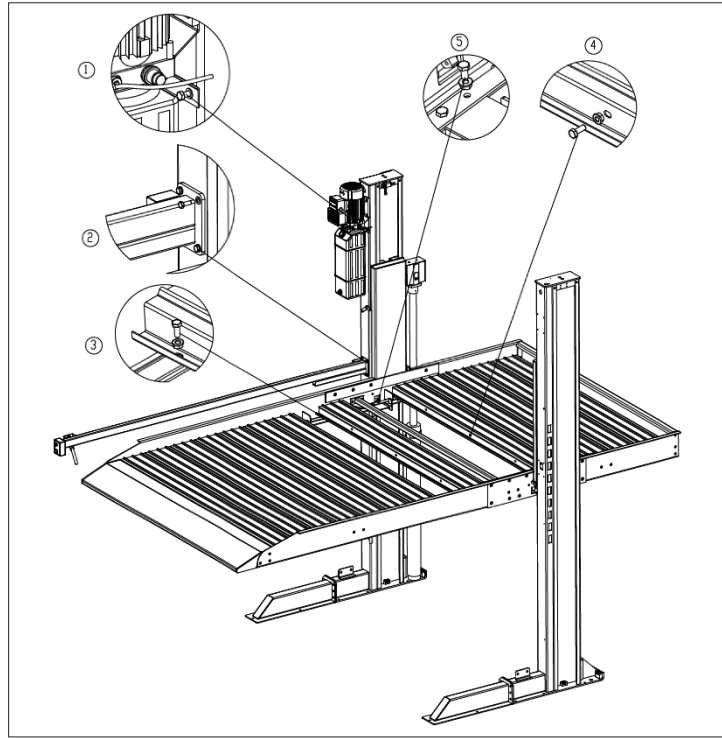

Item	P/N	Description	Qty.
1	5530304	HHB M8 x 1.25 x 20mm	4
1	5545340	WASHER; M8 x OD-24mm FLAT	4
2	5530025	HHB M8 x 1.25 x 12mm	4
2	5545340	WASHER; M8 x OD-24mm FLAT	4
3	5530304	HHB M8 x 1.25 x 20mm	34
3	5535052	M8 Flanged Nut with Serration	34
4	5530304	HHB M8 x 1.25 x 20mm	48
4	5535052	M8 Flanged Nut with serration	48
5	5530738	HHB M10 x 1.5 x 25mm	2
5	5535053	M10 x 1.5 Flanged Nut with serration	2

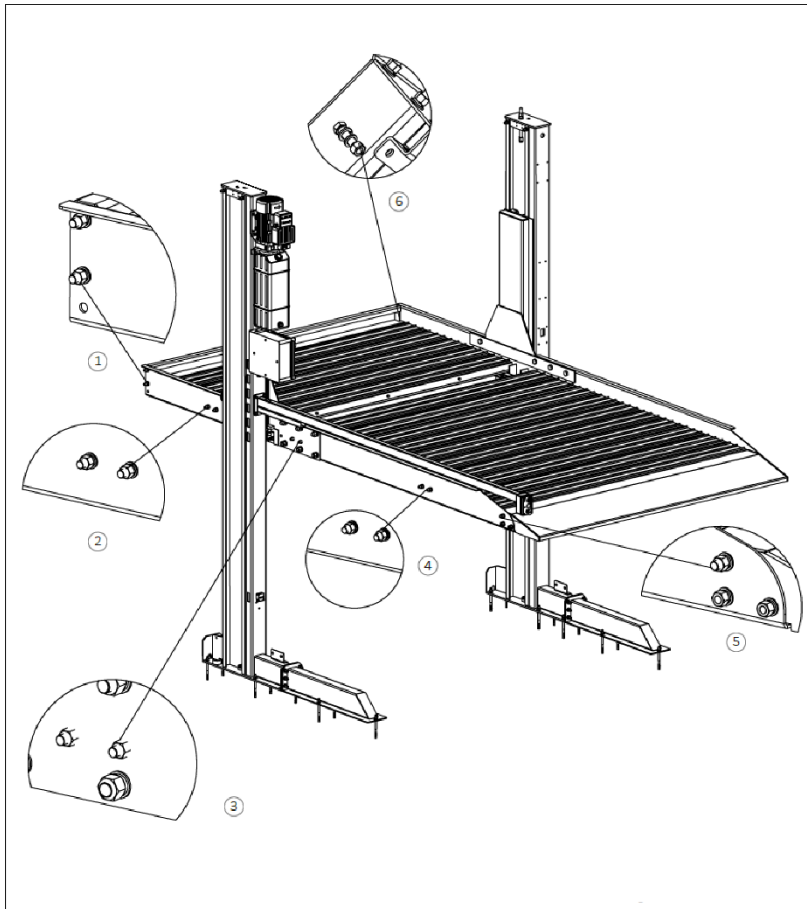

Item	P/N	Description	Qty.
1 thru 4	5530107	HHB M14 x 2.0 x 40mm	4
1 thru 4	5545349	WASHER M14 SL	4
1 thru 4	5545015	WASHER; M14 FLAT	4
1 thru 4	5403361	NUT; M14 x 2.0	4
5 thru 6	5530107	HHB M14 x 2.0 x 40mm	2
5 thru 6	5545349	WASHER M14 SL	2
5 thru 6	5545015	WASHER; M14 FLAT	2
5 thru 6	5403361	NUT; M14 x 2.0	2

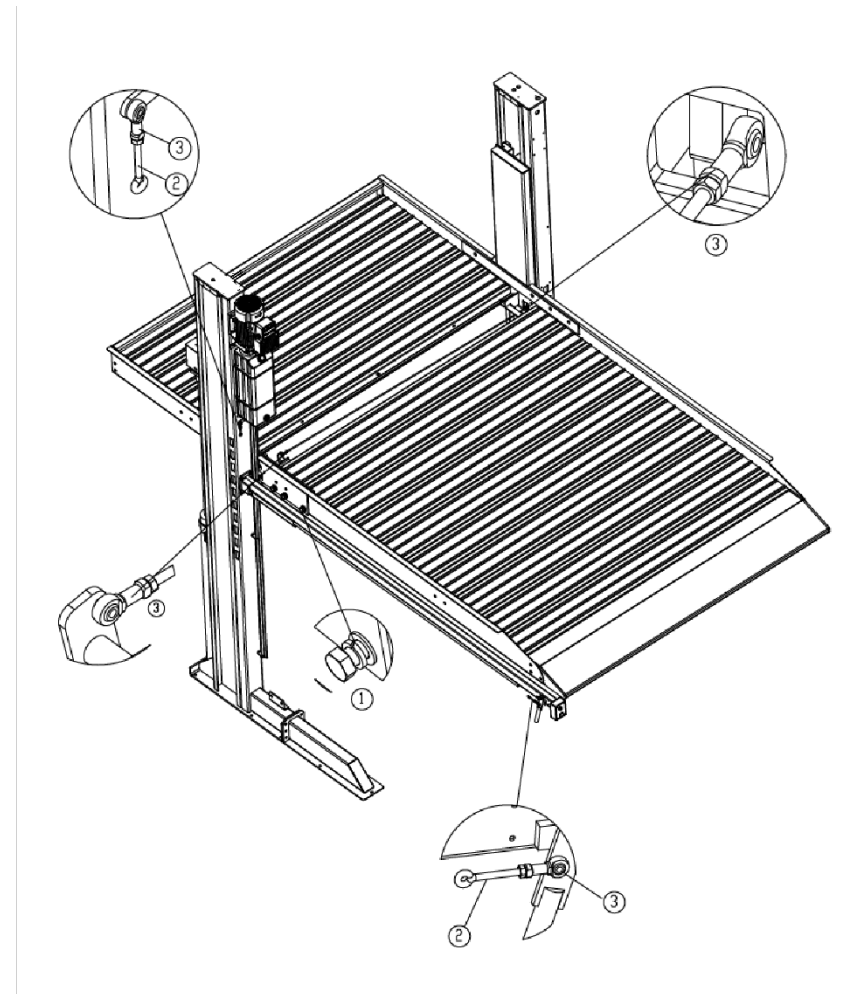

Item	P/N	Description	Qty.
1	5545022	WASHER M20 SL	8
1	5545343	WASHER; M20 x OD-37mm FLAT	8
1	5535303	NUT; M20 x 2.5	8
2	5530478	Adjustable Rod M6	2 pcs.
3	5505625	Articulated Bearing M6	6 pcs.

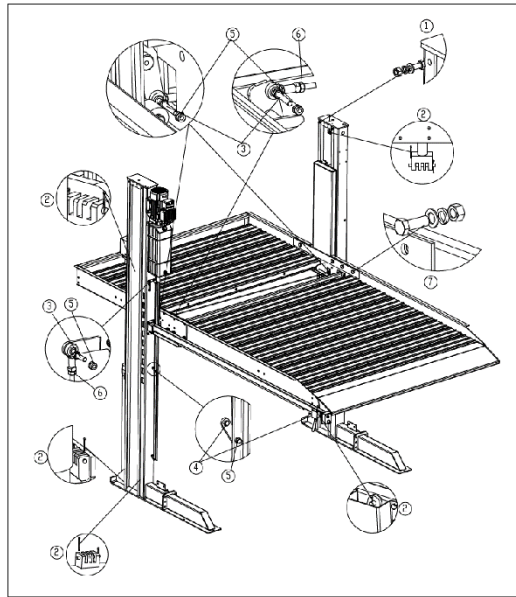

Item	P/N	Description	Qty.
1	5530021	HHB M10 x 1.5 x 30mm	8
1	5545200	WASHER M10 SL	8
1	5545341	WASHER; M10 x OD-20mm FLAT	8
1	5535998	NUT; M10 x 1.5	8
2	5505006	Split Pin 2 x 20	10 pcs.
3	5530027	HHB M6 x 1.0 x 35mm	5 pcs.
4	5530756	HHB M6 x 1.0 x 25mm	9
4	5546026	WASHER M6 SL	9
4	5545339	WASHER; M6 x OD-18mm FLAT	9
4	5535112	NUT; M6 x 1.0	9
5	5535357	NUT M6 x 1.0 NL NYLOC	9 pcs.
6	5535112	NUT; M6 x 1.0	6 pcs.
7	5174104	Hex Bolt M20 x 55	8
7	5545022	WASHER M20 SL	8
7	5545343	WASHER; M20 x OD-37mm FLAT	8
7	5535303	NUT; M20 x 2.5	8

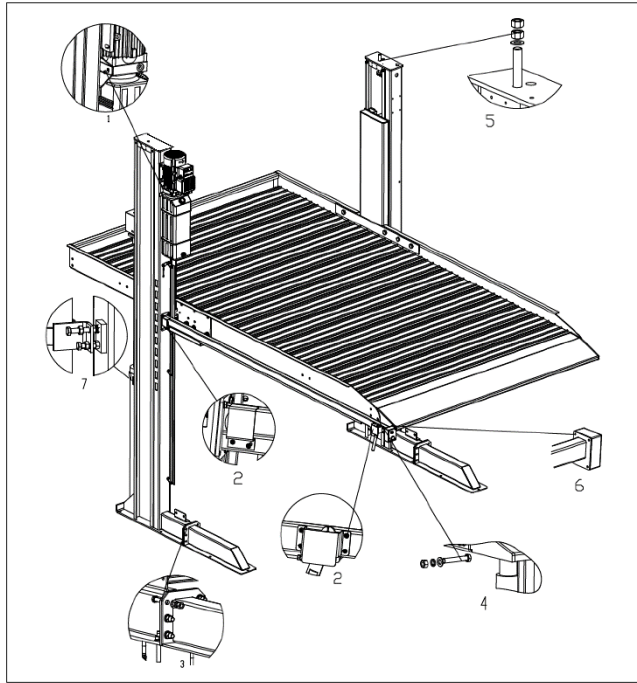

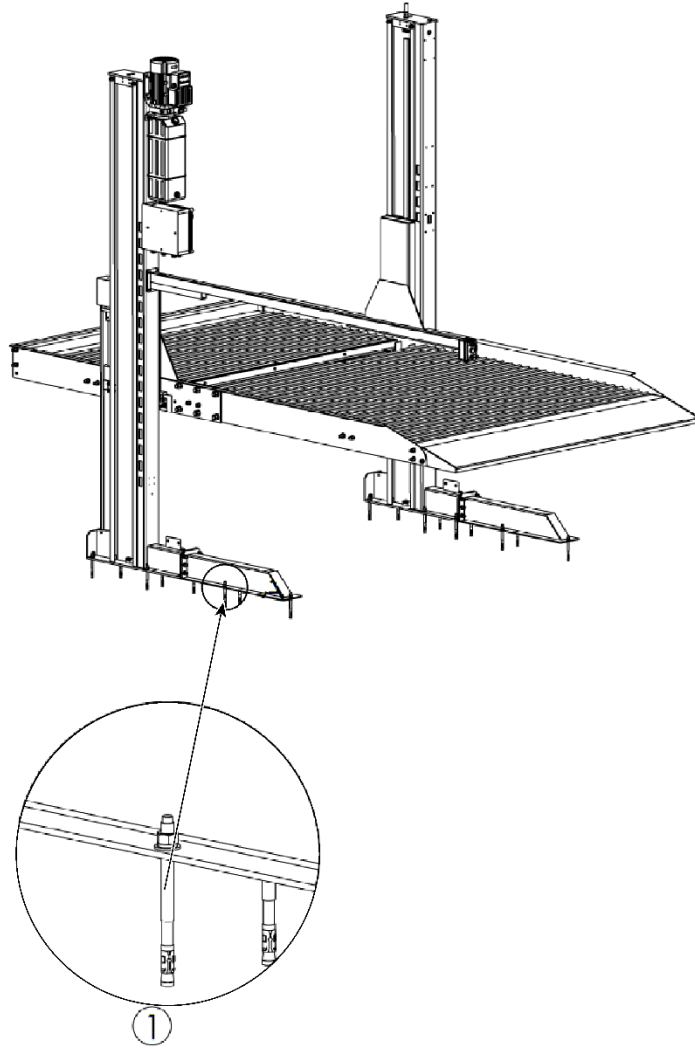

Item	P/N	Description	Qty.
1	5530755	HHB M10 x 1.5 x 18mm	2 pcs.
2	Spare	Spare	Spare
3	5530792	HHB M12 x 1.75 x 45mm	12
4	5530477	M14 x 2 x 100 Hex Head Bolt	4
4	5545349	WASHER M14 SL	4
4	5545015	WASHER; M14 FLAT	4
4	5403361	NUT; M14 x 2.0	4
5	5535054	Nut M18 x 1.5(Chain Adjustment Nut)	4 pcs.
5	5545342	WASHER; M18 x OD-34mm FLAT	2 pcs.
6	5530174	PHPS M4 x 0.7 x 20mm	4 pcs.
6	5535016	NUT M4 x 0.7	4 pcs.
7	5530092	HHB M10 x 1.5 x 55mm	2 pcs.
7	5535998	NUT; M10 x 1.5	6 pcs.





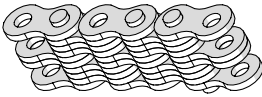
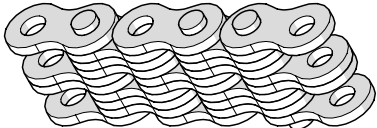
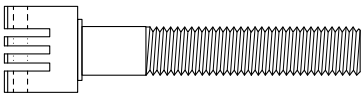
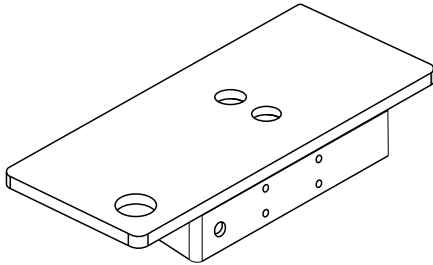
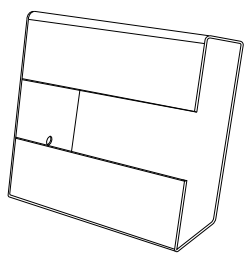
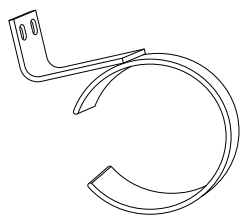
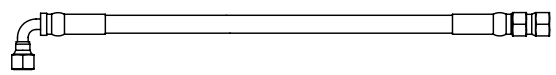

Item	P/N	Description	Qty.
1	5530337	Anchor Bolt M12 x 160	18 sets

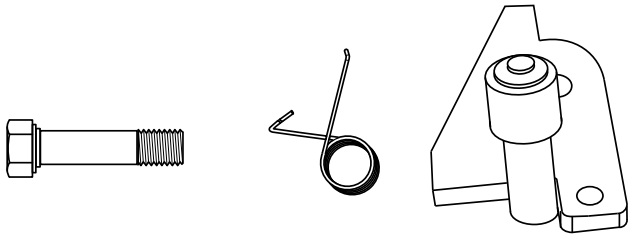
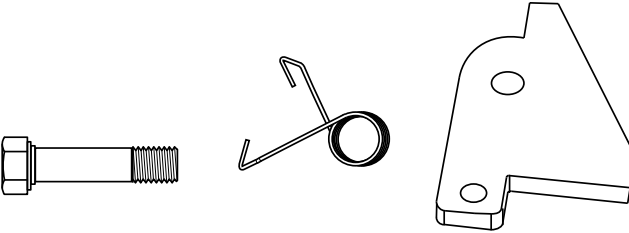
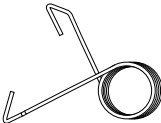
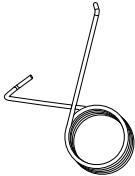
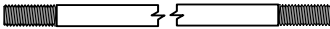
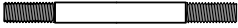
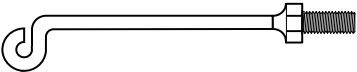
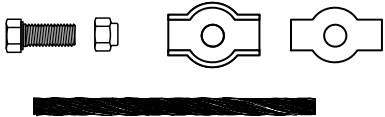
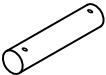
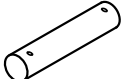
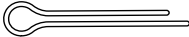
Additional Spare Parts Ordering Information

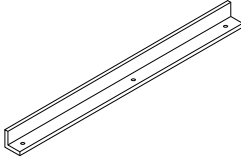
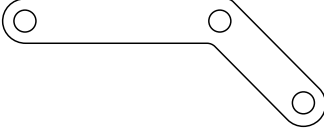
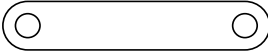
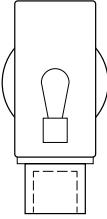
Illustration	P/N	Description	Qty.
	5510010	Chain, Balance	1
	5510011	Chain, Lift	1
	5746652	Chain Mount, Adjustable	1
	5601798	Cover Plate, Top	2
	5701840	Cover, Chain Roller (Lift)	1
	5601799	Cylinder Bracket	1
	5570276	Hose, Hydraulic	1
	5905793	Label Set	1 Set

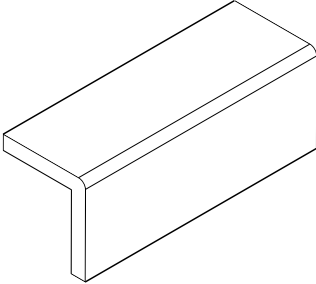
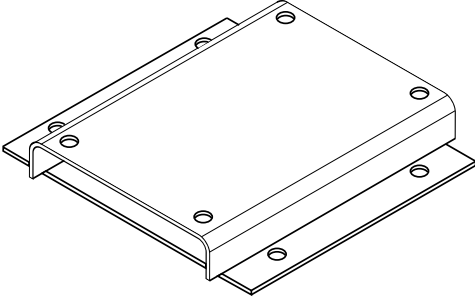
	5216123	Lock, Safety Assm. Power Side (Lock, Spring, Pivot Bolt)	1 Assy.
	5216124	Lock, Safety Assm. Offside (Lock, Spring, Pivot Bolt)	1 Assy.
	5540056	Spring (only), Safety Lock Offside	1
	5540057	Spring (only), Safety Lock Power Side	1
	5530454	Threaded Rod, Safety Release Long (Rod Only)	1
	5530457	Threaded Rod, Safety Release short (Rod Only)	1
	5530458	Support, Threaded Rod Safety Release	1
	5595724	Wire Rope and Clamp Assm. (Safety Lock Release)	1
	5216125	Pin, Balance Chain Anchor Ø5mm x 50mm	2
	5216184	Pin, Lift Chain Anchor Ø8mm x 65mm	2
	5505006	Pin (only), Split 2mm	8

	5721032	Release Angle, Safety Lock Length ≈75 in. (1905 mm)	1
	5737322	Rocker Arm (only) angled Safety Release Mechanism	1
	5737323	Rocker Arm, straight (Safety Release)	2
	5216126	Roller for Chain Assm. (Lift Chain)	1 Assy.
	5216127	Roller Assy. (for Balance Chain) roller, pin, and hex bolt	1 Assy.
	5716082	Slide Blocks	8
	5701868	Bracket, Power Unit Mounting Weldment	1
	5602020	PL-6000DC Drive-Up Weldment	1

Base Plate Hole Pattern PL-6000DC

This Hole Pattern is provided for reference only. BendPak strongly advises you to use the Post Bases as templates when drilling the Anchor Holes.

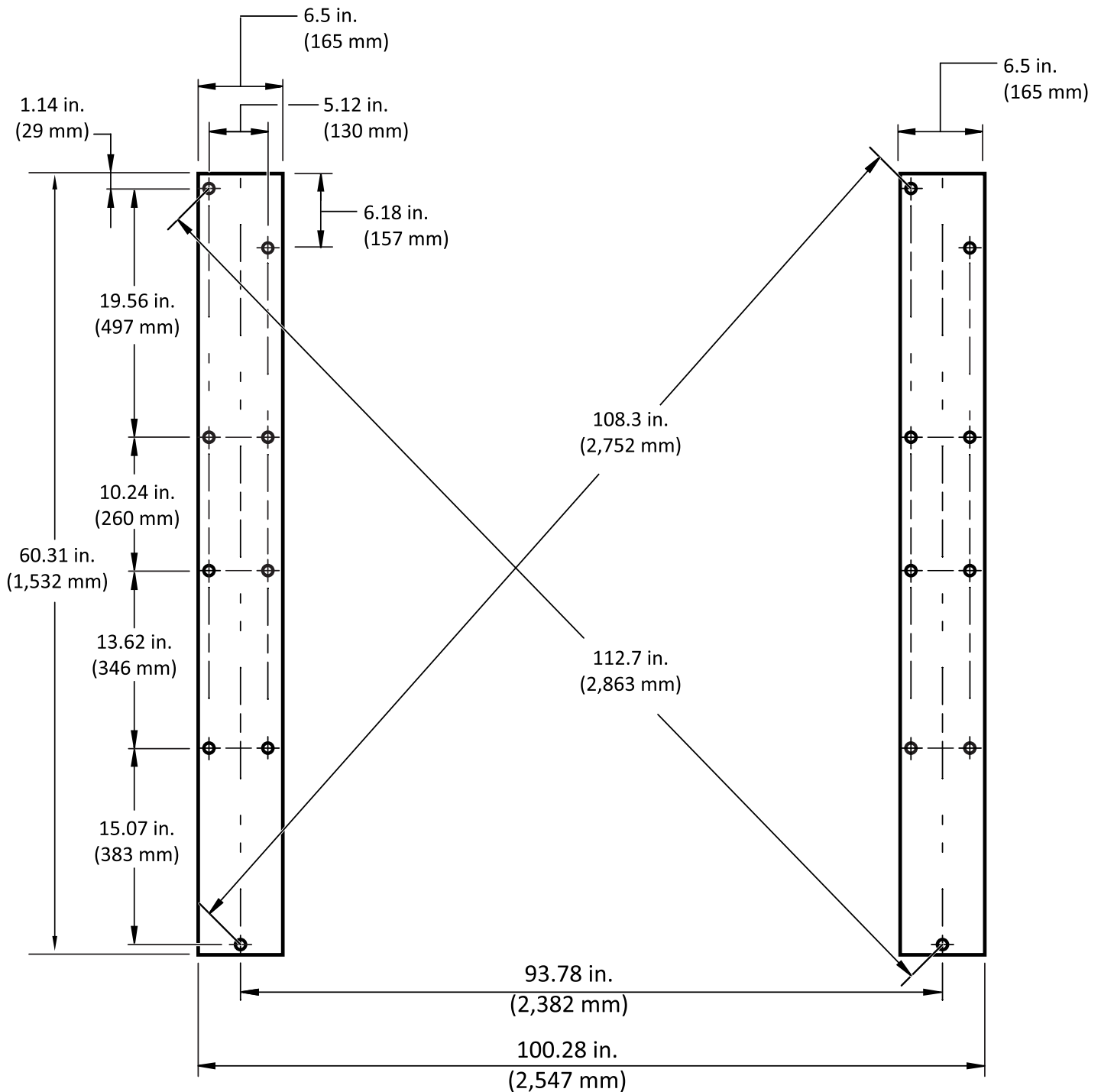

Base Plate Hole Pattern PL-6000DCX

This Hole Pattern is provided for reference only. BendPak strongly advises you to use the Post Bases as templates when drilling the Anchor Holes.

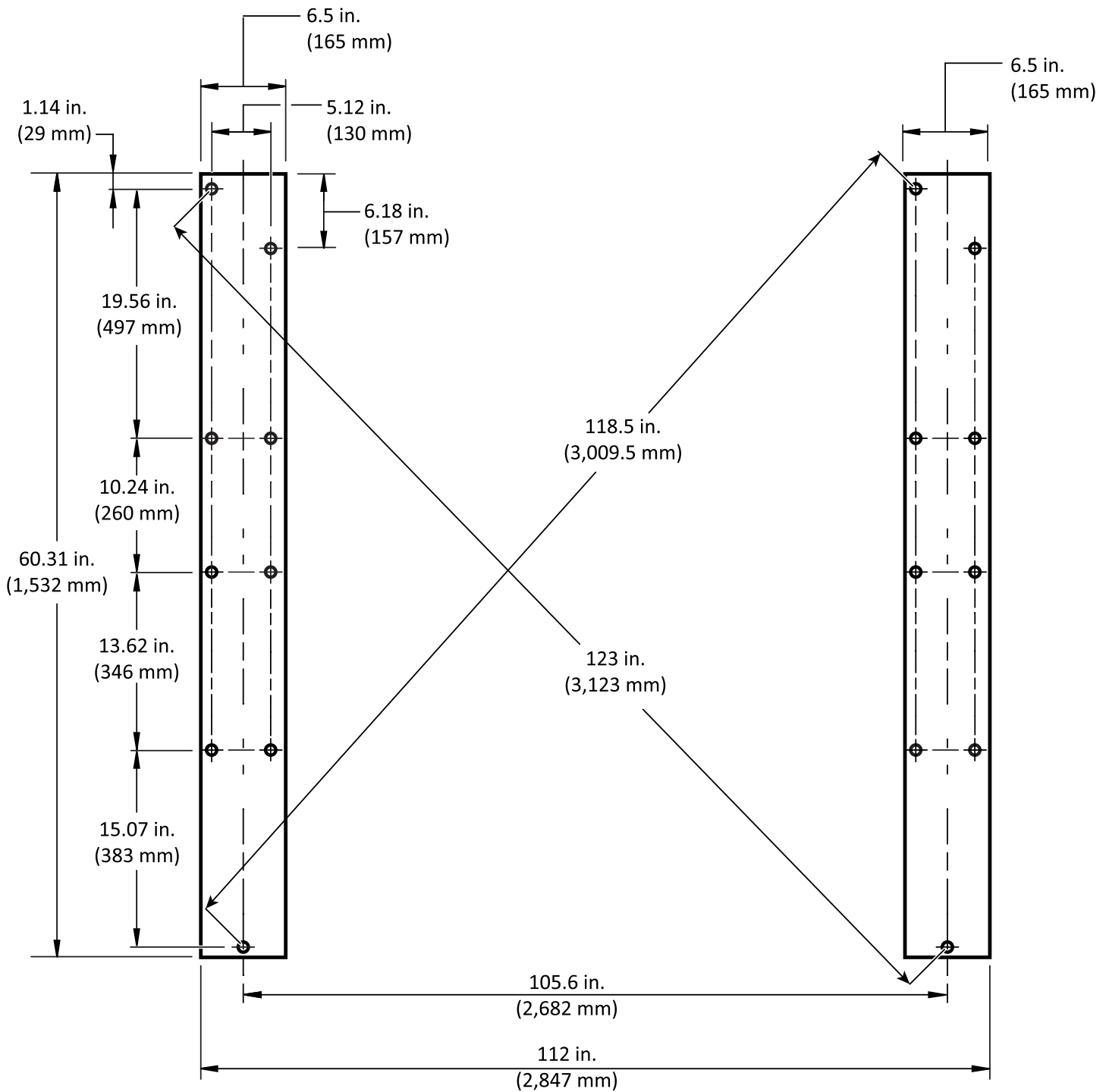

Automotive Lift Institute (ALI) Store

Did you know the **ALI Store** (www.autolift.org/ali-store/) offers a wide variety of professional, easy-to-use, and reasonably priced training and safety materials that will make your garage a safer place to work?

The ALI Store is your trusted source for workplace safety!



Lifting It Right Online Certificate Course. Make *sure* you and your people are lifting vehicles the right way.



ALI Lift Inspector Certification Program Registration. Become a ALI Certified Lift Inspector.

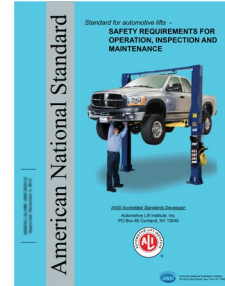

ANSI/ALI ALOIM Standard for Automotive Lifts. Safety Requirements for Operation, Inspection, and Maintenance.

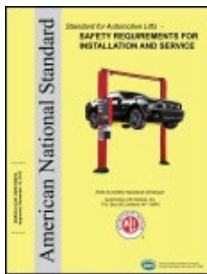

ANSI/ALI ALIS Standard. Safety Requirements for Installation and Service.

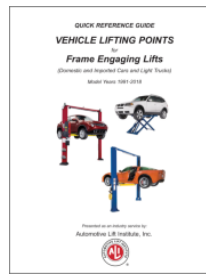

Guide to Hitting Vehicle Lifting Points for Frame-Engaging Lifts. Don't eyeball your lifting points, *know* where they are.



Lift Operator Safety Materials. Five safety documents in a single package.

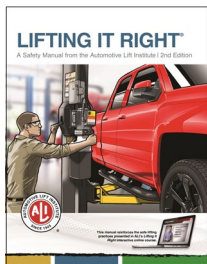

Lifting It Right. A hardcopy version of the *Lifting It Right* safety manual from the Automotive Lift Institute.



Uniform Warning Labels and Placards for 2-Posts. Labels in Mandarin, French Canadian, and Spanish are also available.



Safety Tips Card. Reminds your people of 13 key safety tips to follow daily.

Visit today and get the training and materials you need to work safely:

www.autolift.org/ali-store/.

BendPak[®]

30440 Agoura Road
Agoura Hills, CA, 91301 USA
[bendpak.com](https://www.bendpak.com)

© 2024 BendPak Inc. All rights reserved.