

Tire Changer

Installation and Operation Manual

Manual P/N 5900450 — Revision A — January 2026

Model:

- AT26
- AT26A

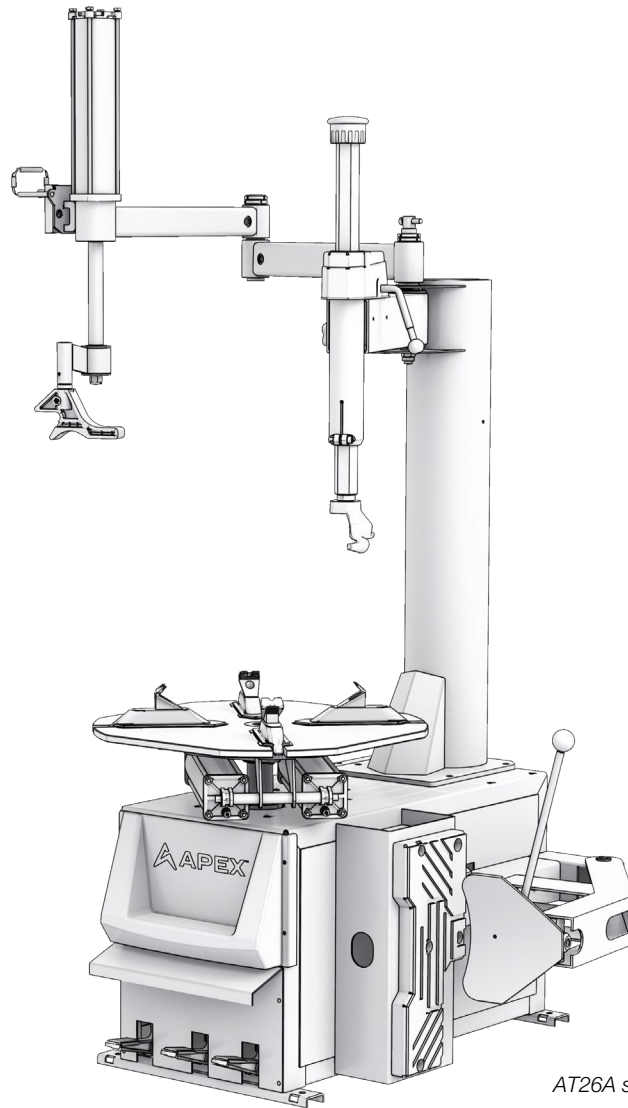

AT26A shown

DANGER

IMPORTANT Safety Instructions, save these instructions! Read the *entire contents* of this manual *before* using this product. Failure to follow the instructions and safety precautions in this manual can result in severe injury or death. Make sure all other operators also read this manual. Keep the manual near the product for future reference. *By proceeding with setup and operation, you agree that you fully understand the contents of this manual and assume full responsibility for product use.*

Manual. Models AT26 Swing-Arm Tire Changer (No Assist Tower) and AT26A Swing-Arm Tire Changer (with Assist Tower), *Installation and Operation Manual*, P/N 5900450, Revision A, released January 2026.

Copyright. Copyright ©2026 by BendPak Inc. All rights reserved. Copies of this document may be made if it is agreed that: full attribution will be given to BendPak Inc., no changes will be made to the content, no rights will be gained to the content, and copies will not be made for commercial purposes.

Trademarks. BendPak, the BendPak logo, APEX, and the APEX logo are registered trademarks of BendPak Inc. All other company, product, and service names are used for identification only. All trademarks and registered trademarks mentioned in this manual are the property of their respective owners.

Limitations. Every effort has been made to have complete and accurate instructions in this manual. However, product updates, revisions, and/or changes may have occurred since this manual was published. BendPak APEX reserves the right to change any information in this manual without incurring any obligation for equipment previously or subsequently sold. BendPak Apex is not responsible for typographical errors in this manual. The latest version of the manual can be found on the [BendPak website](#).

Warranty. The BendPak APEX warranty is a commitment to the value of the product. For full warranty details, contact the nearest BendPak APEX dealer or visit Bendpak.com/support/warranty.

Safety. This product was designed and manufactured with safety in mind. Installer and operator safety depends on proper training and thoughtful operation. Do not set up, operate, maintain, or repair the unit without reading and understanding this manual and the labels on it. ***Do not use this product unless it can be done so safely!***

Owner Responsibility. In order to properly maintain the product and ensure operator safety, it is the responsibility of the product owner ***to read and follow these instructions***.

- Follow all installation, operation, and maintenance instructions.
- Make sure product installation and operation conforms to all applicable local, state, and federal codes, rules, and regulations, such as state and federal OSHA regulations and electrical codes.
- Read and follow all safety instructions. Keep them readily available for operators.
- Make sure all operators are properly trained, know how to safely operate the unit, and are properly supervised.
- Do not operate the product until it is certain all parts are in place and operating correctly.
- Carefully inspect the product on a regular basis and perform all maintenance as required.
- Service and maintain the unit only with approved replacement parts.
- Keep the manual with the product and make sure all labels are clean and visible.

Only use this product if it can be used safely!

Unit Information.

Enter the Model Number, Serial Number, and the Date of Manufacture from the label on the unit. This information is required for part or warranty issues.

Model: _____

Serial: _____

Date of Manufacture: _____

Designed and engineered in Southern California, USA.
Made in China.

Table of Contents

Introduction	3	Operation	25
Shipping Information	4	Maintenance	53
Safety Considerations	4	Troubleshooting	56
Components	6	Wiring Diagram	58
FAQs	8	Labels	59
Specifications	9	Parts	62
Installation Checklist	10	Maintenance Log	84
Installation	11		

Introduction

This manual describes the installation and operation of the APEX Model AT26 Swing-Arm Tire Changer and the AT26A Swing-Arm Tire Changer with Assist Arm. The AT26 and AT26A are used for mounting and demounting tires from single piece wheels on automobiles and light trucks. The AT26A includes an Assist Tower used to aid the operator in mounting and demounting tires.

Important: The AT26 does *not* include an Assist Tower or its tools.

More information about APEX products is available at <http://www.bendpak.com>.

This manual is mandatory reading for all users of the AT26 and AT26A, including anyone who sets up, operates, maintains, or repairs one.

The latest version of the manual can be found on the [BendPak website](#).

 DANGER Be very careful when setting up, operating, maintaining, or repairing this equipment; failure to do so could result in property damage, product damage, injury, or (in very rare cases) death. Make sure only authorized personnel operate this equipment. All repairs must be performed by an authorized technician. Do not make modifications to the unit as this voids the warranty and increases the chances of injury or property damage. Make sure to read and follow the instructions on the labels on the unit.

Keep this manual on or near the equipment so that anyone who uses or services it can read it.

Technical support and service is available from the distributor or by calling APEX at **(877) 432-6627**. Parts replacement is also available (please have the serial number and model number of the unit available).

Shipping Information

This equipment was carefully checked before shipping. Nevertheless, the shipment should be thoroughly inspected **before** signing to acknowledge that it has been received.

Signing the bill of lading tells the carrier that the items on the invoice were received in good condition. **Do not sign the bill of lading until after the shipment has been inspected.** If any of the items listed on the bill of lading are missing or damaged, do not accept the shipment until the carrier makes a notation on the bill of lading that lists the missing or damaged goods.

If missing or damaged goods are discovered **after** receiving the shipment and the bill of lading has been signed, notify the carrier at once and request that the carrier perform an inspection. If the carrier will not perform an inspection, prepare a signed statement to the effect that the carrier has been notified (on a specific date), and that the carrier has failed to comply with the request.

It is difficult to collect for loss or damage after giving the carrier a signed bill of lading. If this happens, file a claim with the carrier promptly. Support the claim with copies of the bill of lading, freight bill, invoice, and photographs, if available. Our willingness to assist in helping to process the claim does not make us responsible for the collection of claims or replacement of lost or damaged materials.

Safety Considerations

Read this entire manual carefully before using the AT26 and AT26A Tire Changers. Do not install or operate the Tire Changer until all installation and operating instructions and warnings are clearly understood. Do not allow anyone else to operate the Tire Changer until they are also familiar with all operating instructions and warnings.

 **DANGER** There are many moving parts on a Tire Changer; keep clear of these moving parts and the tire being changed. In particular, when inflating a tire, never lean over it; if it were to explode (which does happen), the force could injure or kill the operator or bystanders. During inflation, the operator should be as far away from the tire as possible and all bystanders must be at least 30 ft. (9.14 m) away.

Safety Information





Please note the following:

- The product is a Tire Changer. **Use it only for its intended purpose.**
- The product **must** only be operated by authorized, trained, properly supervised personnel. Keep children and untrained personnel at least 30 ft. (9.14 m) away from the product when it is in use.
- Always follow all applicable local, state, and federal codes, rules, and regulations, including (but not limited to) OSHA standard 1910.177 (Servicing multi-piece and single piece rim wheels).
- All users **must** wear OSHA-approved (publication 3151) Personal Protective Equipment at all times when installing, using, maintaining, or repairing the Tire Changer. Leather gloves, steel-toed work boots, eye protection, back belts, and hearing protection **are mandatory.**
- Do not use the Tire Changer while tired or under the influence of drugs, alcohol, or medication.
- Do not use the Tire Changer in the presence of cigarette smoke, dust, or flammable liquids or gases. Use the product indoors only, and in a well-ventilated area.
- Do not make any modifications to the product; this voids the warranty and increases the chances of injury or property damage. **Do not modify any safety-related features in any way.**

-
- Make sure all operators read and understand this *Installation and Operation Manual*. Keep the manual near the Tire Changer at all times.
 - Make a visual inspection of the Tire Changer every day. Do not use it if any missing or damaged parts are found. Instead, take the Tire Changer out of service and contact an authorized repair facility, the distributor, or APEX at **(877) 432-6627**.
 - APEX recommends making a **thorough** inspection of the product once a month. Replace any damaged or severely worn parts, decals, or warning labels.

Symbols

Following are the symbols that may be used in this manual:

-  **DANGER** Calls attention to a hazard that **will** result in death or injury.
-  **DANGER** Calls attention to an electrical hazard that **will** result in death or injury.
-  **WARNING** Calls attention to a hazard or unsafe practice that **could** result in death or injury.
-  **CAUTION** Calls attention to a hazard or unsafe practice that could result in personal injury, product damage, or property damage.
- NOTICE** Calls attention to a situation that, if not avoided, could result in product or property damage.
-  **Tip** Calls attention to information that can help us to use the product better.

Liability Information

APEX assumes **no** liability for damages resulting from:

- Use of the equipment for purposes other than those described in this manual.
- Modifications to the equipment without prior, written permission from APEX.
- Damage to the equipment from external influences.
- Incorrect operation of the equipment.
- Injury or death caused by modifying, disabling, overriding or removing safety features.

Components

The following illustration identifies the main components of the APEX AT26/26A Tire Changers.

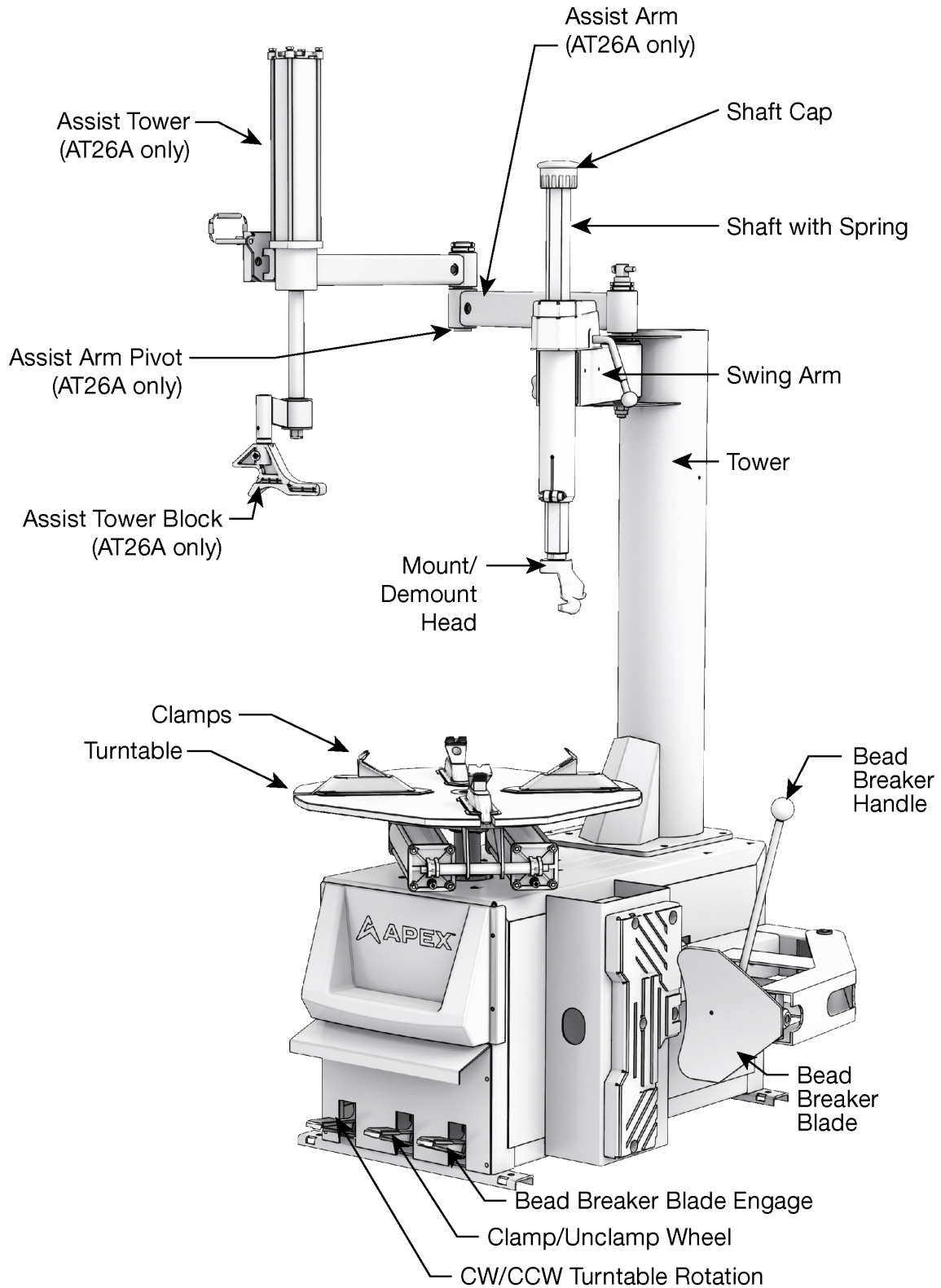

Model AT26A. Not all components shown

Tire Changer components include:

- **Turntable.** Holds and rotates the wheel, and has the Wheel Clamps built in.
- **Wheel Clamps.** As part of the Turntable, the Wheel Clamps hold the wheel in place.
- **Tower.** Supports the Swing Arm and the Assist Tower.
- **Swing Arm.** Holds the Mount/Demount Head. Moves to the right up to 90° when not required. Installation required.
- **Assist Tower.** AT26A only. Holds additional tools that can be used during mounting and demounting. Installation required.
- **Mount/Demount Head.** Mounts and demounts tires. Located on the bottom of the Shaft. The Tire Changer comes with an alloy steel head as well as a plastic, non-marring head.
- **Shaft.** Moves up and down and controls the position of the Mount/Demount Head.
- **Shaft Cap.** Used to move the Shaft *down, to position* the Mount/Demount Head to the desired height.
- **Swing Arm Control.** Stops the Swing Arm from moving past a specific, chosen point.
- **Bead Breaker.** Breaks the beads of a tire so it can be dismounted. Located on the right side of the Tire Changer. Includes a handle, blade, and a movable mechanism.
- **Bead Lifting Tool.** A hand tool used to pull the bead edge of a tire over the Mount/Demount Head so the tire can be demounted from the wheel. Can also be used to hold down a tire sidewall during tire mounting.
- **Inflation Air Gun with Chuck and Inflation Gauge.** Adds air to a tire. The Inflation Gauge shows the amount of air pressure currently in a tire. Includes an Air Chuck with self-gripping clip and a pressure release button.
- **Lube Bucket.** Holds tire lubricant. Use a lubricant approved by the tire manufacturer for the tire being changed.
- **Lube Brush.** Applies the tire lubricant.
- **Bead Breaker Foot Pedal.** Moves the Bead Breaker Blade in.
- **Clamps In/Out Foot Pedal.** Moves all four Wheel Clamps in or out.
- **Turntable Foot Pedal.** Rotates the Turntable. Press down and hold down to rotate the Turntable clockwise, press up and hold up to rotate the Turntable counterclockwise.
- **Regulator/Filter.** Controls the pressure of, and removes the water from, the incoming air supply.
- **Lubricator.** Adds lubrication to the incoming air for tools on the Tire Changer that require it.
- **Voltage Switch.** Located on the back of the unit, it switches the Tire Changer's motor between 110 VAC and 220 VAC operation. Use with **caution** (refer to **Connecting to Power** for detailed information). The Tire Changer comes from the factory set to 110 VAC and the Power Cord has a 110 VAC Plug.

Frequently Asked Questions

Question: What does a tire changer do?

Answer: A tire changer removes tires from wheels (dismounting), puts tires onto wheels (mounting), and inflates tires.

Q: What are the steps in the process of dismounting a tire and then mounting a new tire?

A: The steps are: deflate the tire, break the bead on both sides of the tire, secure the wheel on the turntable, dismount the tire, mount the new tire, inflate the new tire, then remove the wheel from the turntable.

Q: What does “break the bead” mean?

A: A tire is held on the rim of a wheel by the tire bead sitting between the rim lip and the bead retainer of the rim (this location is called the bead seat). The air pressure in the tire holds it in place once the bead is seated (during mounting). “Breaking the bead” means moving the tire bead out of the bead seat, which is required to dismount the tire.

Q: Can I break the bead without fully deflating the tire?

A: No, do not do this. ***Always fully deflate a tire before attempting to break its bead.*** The air pressure energy in a tire, even if not fully inflated, can be considerable. When attempting to break the bead of a tire not fully deflated, the air pressure energy would be released all at once, possibly injuring or, in rare cases, killing the operator or bystanders.

Q: What important thing should I always do when working with the tire changer?

A: The first step is to identify and correctly match the tire and wheel/rim diameters of the tire to be mounted; they must match exactly. If they do not match exactly, this is called a tire mismatch. The result of a mismatch is that the tire could literally explode off the wheel while inflating, or even while the vehicle is being driven. In both cases, people could be injured or killed. Note that the phrase “tire mismatch” is also used to mean tires on a single vehicle with different tread patterns or from different manufacturers. This is not what is being described here. APEX recommends getting and reading OSHA standard 29 CFR 1910.177 (Servicing Multi-Piece and Single Piece Rim Wheels) for additional information.

Q: Where should I put my tire changer?

A: Place the tire changer on a flat concrete floor, with clearance around it, that is also near where tires are being worked on. Ideally, away from high traffic areas, as bystanders must be kept away from the tire changer while it is in use. No one other than the operator should be within 30 ft. (9 m) of the tire changer while it is in use. Refer to the **Clearance** section.

Q: Why is there a 110 VAC plug on the power cord? I want to use a 220 VAC power source.

A: The tire changer comes configured from the factory for 110 VAC operation. However, it may be converted to 220 VAC. Conversion requires a licensed electrician. Refer to **Connecting to Power** for complete instructions for switching. Pay careful attention to the instructions for switching input voltage. If done incorrectly, the tire changer could be damaged.

Specifications Model AT26 and AT26A

Specification	Performance
Motor	110/220 VAC, 50-60 HZ, 1 Ph., 1.1kW*
Power Cord Length	8 ft. (2.4 m)
Drive System Type	Electric / Air
Air Requirement	116 – 145 PSI (8 – 10 BAR) at 15-25 CFM
Wheel Clamping Method	4 Clamps – Internal / External
Table Clamping System	Dual Pneumatic Cylinders
Bead Breaking System	Pneumatic Blade
Tower Design	Rigid Fixed / Swing Arm
Assist Tower Design	Swing Arm (Model AT26A Only)
Rim Size Clamping Min.-Max.**	12-26 in.
Actual Clamping Diameter Min.-Max.	13.5-27.5 in. (345-700 mm)
Turntable Rim Width Capacity	3 – 15 in. (76 – 381 mm)
Bead Breaker Rim Width Capacity	3 – 14 in. (76 – 356 mm)
Maximum Tire Diameter	47 in. (1200 mm)
Noise	<70 dB
Operating Temperature	+39° to +104°F /+4° to +40°C
Operating Humidity	90% at 20°C and 50% at 40°C Non-Condensing
Dimensions	35 in. wide by 38 in. deep by 76.25 in. high 890 mm wide by 965 mm deep by 1,935 mm high

*Factory configured for 110 VAC operation. However, it may be switched to 220 VAC. Refer to **Connecting to Power** for instructions. A licensed electrician is required to switch to 220 VAC.

Rim size indicates the bead seat diameter **not the outside diameter of the wheel.

Specifications subject to change without notice.

Installation Checklist

Following are the steps needed to install the Tire Changer. Perform them in the order shown.

- 1. Review the installation Safety Rules.
- 2. Make sure all the necessary tools are readily available.
- 3. Find an appropriate location.
- 4. Make sure there is adequate clearance around and above the Tire Changer.
- 5. Unpack the unit.
- 6. Move the Tire Changer to its permanent location.
- 7. Anchor the unit.
- 8. Install the Tower, Inflation Air Gun and Bead Breaker
- 9. Install the Swing Arm.
- 10. Assist Arm motion adjustment, if required. (AT26A Only)
- 11. Connect to air.
- 12. Connect to power. **Switching to 220 VAC operation requires a licensed electrician.**
- 13. Prepare the Lube Bucket.
- 14. Leave the Installation and Operation Manual with the Tire Changer.

Installation

This section describes how to install the APEX AT26 and AT26A Tire Changers. Perform the steps in the order presented.

Installation Safety Rules

Pay attention at all times during installation. Use appropriate tools and equipment. Stay clear of moving parts. Keep hands and fingers away from pinch points. ***Safety must always be the top priority.***

Use caution when unpacking the Tire Changer from its shipping container and setting it up. The Tire Changer is heavy and the weight is not evenly distributed. Dropping or knocking over the unit may cause equipment damage and personal injury.

⚠ WARNING Installers and operators ***must*** wear OSHA-approved (publication 3151) Personal Protective Equipment at all times when installing, using, maintaining, or repairing the Tire Changer: leather gloves, steel-toed work boots, eye protection, back belts, and hearing protection.

Only experienced, trained technicians may install the Tire Changer. In particular, all electrical work ***must*** be accomplished by a licensed electrician.

⚠ CAUTION Certain installation steps may be difficult for one person to perform. APEX ***strongly*** recommends having two or more persons work together to install the unit.

Tools

The following tools are required:

- Forklift, pallet jack, or shop crane
- Utility knife
- Hammer, mallet, crowbar, or pry bar
- Tin or sheet metal snips
- Hex key and wrench set, metric and SAE
- Screwdriver set, flat head and Phillips
- Hammer drill and masonry drill bit.

Finding a Location

Keep the following in mind when deciding on a location:

- **Power source.** The tire changer needs to be near an appropriate power source.
- **Floor.** The Tire Changer needs to be anchored on a flat, concrete floor.
- **Clearance.** The Tire Changer needs space around it. Refer to **Clearance** for more information.
- **Access.** Adequate working space is required to move tires to and from the tire changer.
- **Danger.** When the Tire Changer is in use, especially during Inflation, everyone except the operator must be kept at least 30 ft. (9.14 m) away.

Do not set up the Tire Changer in a well-travelled area.

- **Keep Away from Water.** The tire changer has electronic components. If it gets wet while connected to power, those electronic components will most likely short circuit and have to be replaced.

⚠ DANGER Do not use the tire changer if it is sitting in water. This will short circuit the electronic components within the unit and the operator and bystanders could be electrocuted.

Clearance

Clearance around and above the equipment is required for safety. Provide adequate clearance around the equipment to ensure safe operation, vehicle positioning, and service access. Surrounding equipment, walls, and structural elements should be arranged to allow free and unobstructed movement of personnel, vehicles, and service equipment such as oil drains, tool carts, and other shop apparatus through adjacent work areas and access lanes. Auxiliary and utility services should be routed so they do not interfere with lift operation or prevent removal of access covers or service panels.

⚠ WARNING The clearance values shown below allow the minimal space to operate the Tire Changer. **For safety purposes, only the operator should be within 30 ft. (9.14 m) of the Tire Changer while it is in use.**

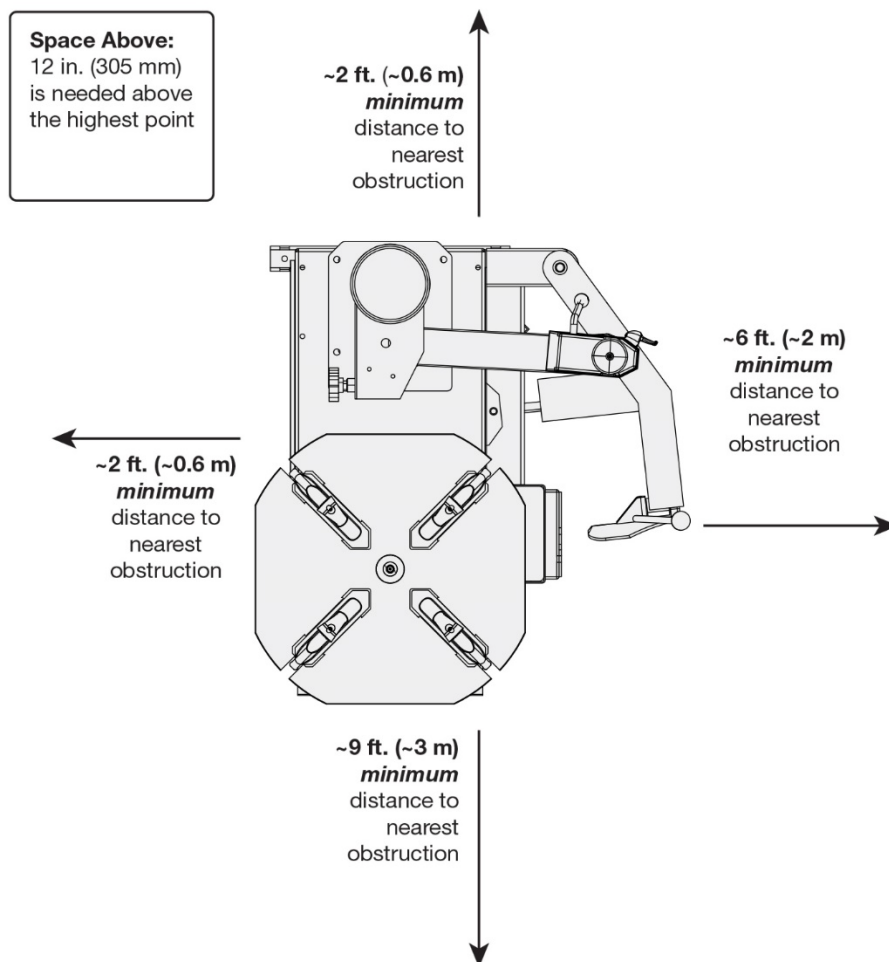

Top view. Not to scale. Not all components shown.

Unpacking

APEX recommends unpacking the Tire Changer as close as possible to its permanent working location. The fewer times that heavy components are moved around, the easier the installation will be.

Note: Many of the Tire Changer components have been greased to protect them during shipping. For cleanup, APEX recommends having some shop towels nearby when unpacking. The grease on the Turntable, the Mount/Demount Head, and the Shaft Lock Handle should be cleaned off, as keeping them greased would hinder normal operation of the unit. However, the Shaft and the Swing Control knob should remain greased.

Use caution when taking the Tire Changer out of its shipping container to avoid damaging the unit, misplacing any of the components, or injuring anyone nearby.

To Unpack the Tire Changer:

1. Make sure all installers and operators are wearing OSHA-approved (publication 3151) Personal Protective Equipment: leather gloves, steel-toed work boots, back belts, hearing protection, and ANSI-approved eye protection (safety glasses, face shield, or goggles).
2. At the bottom of the packing crate cover, push the metal tabs all the way down, on all four sides. Some force may need to be applied to get all of the metal tabs free, as they sometimes stick.
3. Lift the crate cover off.

 **CAUTION** APEX recommends having at least two people lift the crate cover off, as it is heavy and awkward. If the crate cover is dropped, it could damage the unit or cause injury.

4. Remove the plastic wrap around the Tire Changer and other components.

Moving the Tire Changer to its Permanent Location

 **WARNING** Make sure to use an appropriate lifting device, such as a forklift or pallet jack, to move the Tire Changer while it is still on its pallet. Make sure only personnel who are experienced with material handling procedures are allowed to move the Tire Changer. The Tire Changer is heavy and the weight is not evenly distributed; dropping or knocking over the unit may cause equipment damage or personal injury. APEX recommends having at least two people work together to move it.

To Move the Tire Changer:

1. Make sure all installers and operators are wearing OSHA-approved (publication 3151) Personal Protective Equipment: leather gloves, steel-toed work boots, back belts, hearing protection, and ANSI-approved eye protection (safety glasses, face shield, or goggles).
2. Remove the shipping bolts that hold the Tire Changer to the pallet.
3. Carefully move the Tire Changer off the pallet.

The Tire Changer can be moved off the pallet using a forklift under either side. **Use care when moving the Tire Changer off the pallet.**

An appropriate lifting device (such as a shop crane) with a strap secured around the unit can also be used to move it into place.

⚠ CAUTION While moving the Tire Changer, be sure to stay clear of pneumatic fittings and plumbing—to prevent damage.

4. Move the Tire Changer to its permanent location.

Anchoring the Tire Changer

The Tire Changer has four .5 in (12.7 mm) holes for anchoring, one at each corner of the base.

Note: APEX recommends anchoring, as the Tire Changer uses force at various times during the changing of a tire. Anchoring ensures it will not move during operation.

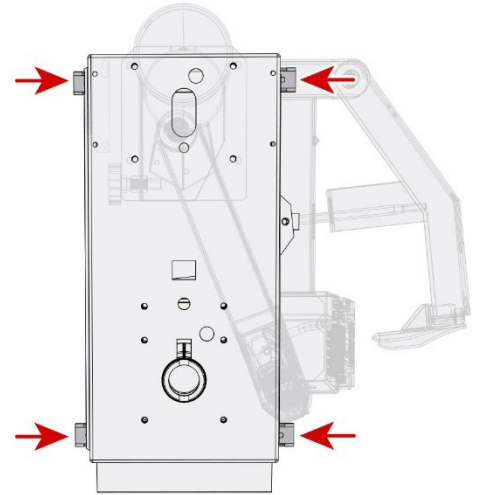

Top View. Not to scale. Some components not shown or ghosted for clarity.

The Anchor Bolts (sometimes called wedge anchors) mentioned in the following procedure are **not** supplied with the Tire Changer. For example, use 3/8 in. wide by 3 in. (76 mm) deep Anchor Bolts to secure the Tire Changer, drilling the hole approximately 2.5 in. (63.5 mm) into the concrete.

To Anchor the Tire Changer:

1. All installers and operators must wear OSHA-approved (publication 3151) Personal Protective Equipment: leather gloves, steel-toed work boots, back belts, hearing protection, and ANSI-approved eye protection (safety glasses, face shield, or goggles).
2. Make sure the Tire Changer is in the desired location.
3. Using the Tire Changer anchor holes as guides, drill four holes for the Anchor Bolts.



Drill in straight; do not let the drill wobble. Use a carbide drill bit (conforming to ANSI B212.15).

Use a drill bit that is the same diameter as the Anchor Bolt. So, when using a 3/8 in. (10 mm) diameter Anchor Bolt, for example, use a 3/8 in. (10 mm) diameter drill bit.

4. Vacuum each hole clean.

APEX recommends using a wire brush and a vacuum to get the hole very clean.

Do **not** ream the hole. Do **not** make the hole any wider than the drill bit made it.

-
5. Make sure the washer and nut are in place, then insert the Anchor Bolt into the Tire Changer anchor hole.

The expansion sleeve of the Anchor Bolt may prevent the Anchor Bolt from passing through the hole in the base of the Tire Changer; this is normal. Use a hammer or mallet to get the expansion sleeve through the base and down into the hole.

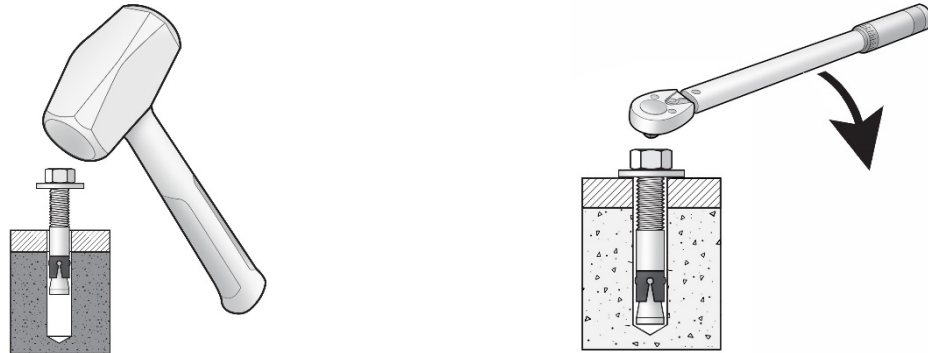

Even using a hammer or mallet, the Anchor Bolt should only go into the hole part of the way; this is normal. If the Anchor Bolt goes all the way in with little or no resistance, the hole is too wide.

Once past the hole in the base, the Anchor Bolt eventually stops going down into the hole as the expansion sleeve contacts the sides of the hole, this is normal.

6. Hammer or mallet the Anchor Bolt the rest of the way down into the hole.
Stop when the washer is snug against the base of the Tire Changer.
7. Use a torque wrench to tighten each nut **clockwise** to the torque recommended by the manufacturer of the Anchor Bolt.

If no torque is specified, APEX recommends ≈ 55 lbf-ft (74 N-m) for a 3/8 in. (10mm) diameter Anchor Bolt.

Important: Do **not** use an *impact* wrench to torque the Anchor Bolts. Tightening the nut forces the wedge up, forcing out the expansion sleeve and pressing it tightly against the concrete.

Installing the Tower, Inflation Gauge and the Bead Breaker

The Tower/Swing Arm, Inflation Gauge and Bead Breaker come uninstalled from the factory. They need to be removed from where they are secured on the shipping pallet and installed on the Tire Changer Cabinet.

To install the Tower:

1. All installers must wear OSHA-approved (publication 3151) Personal Protective Equipment: leather gloves, steel-toed work boots, back belts, hearing protection, and ANSI-approved eye protection (safety glasses, face shield, or goggles). The Tire Changer is liberally coated with grease to protect it during shipment and storage. Wear gloves and keep rags nearby to clean up excess grease.
2. Carefully remove the plastic protecting the Tire Changer and retain the parts located in bubble wrap or plastic bags.
3. The Tower comes secured to the shipping pallet in several locations. **Carefully** remove the bolts that secure the Tower to the shipping pallet.
4. After removing the bolt securing the top of the Tower to the shipping pallet, remove the plastic bushing that protects the threaded boss. To remove the plastic bushing, use a pair of needle nose pliers to grab and rotate the bushing out of the boss. Install the Swing Arm Control in its place. See illustration to the right.
5. Stand up the Tower, then move the Tower Base over the Tire Changer Cabinet, lining up the four holes in the base over the four large holes in the top of the Cabinet. See illustration to the right.
6. Use the four bolt/washer pairs and a 19 mm wrench to securely bolt the Tower into position on top of the Cabinet.

⚠ WARNING Use care when moving the Tower; it is heavy and not evenly balanced. If it is dropped, injuries and damage to the unit could occur. Make sure to orient the Tower as shown in the illustration to the right.

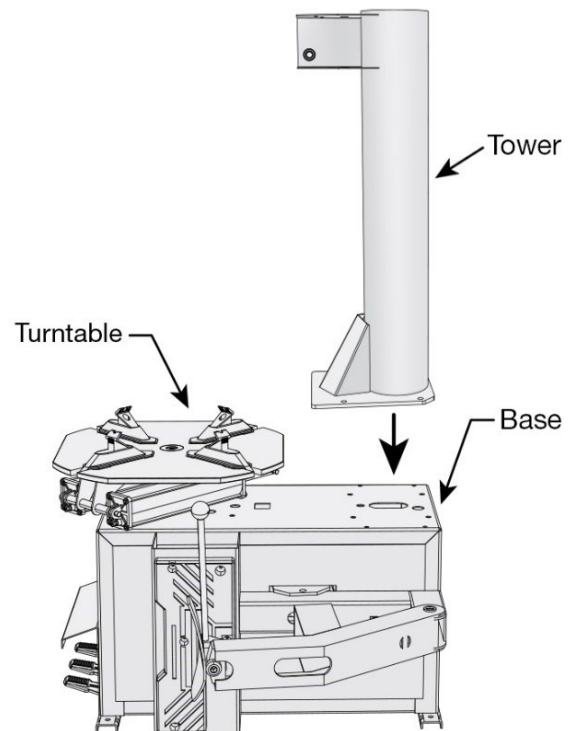

Not to scale, not all components shown.

Installing the Swing Arm:

1. The Swing Arm is mounted at the top of the main tower, and includes the Mount/Demount Shaft and Head Assembly.
2. It is recommended that two people work together to install the Swing Arm, one to position and hold it in place while the other person inserts the Swing Arm Pivot Pin.

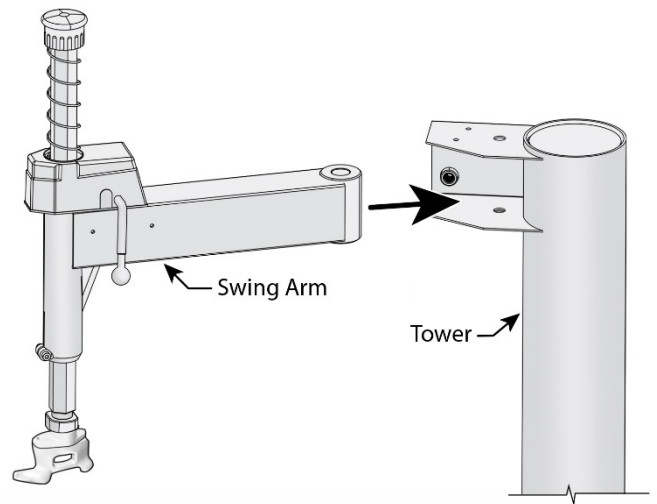

3. Insert the Swing Arm Pivot Pin through the bracket on the Tower, the Top Spacer, the Swing Arm, the Bottom Spacer and through the bottom Bracket as shown below.

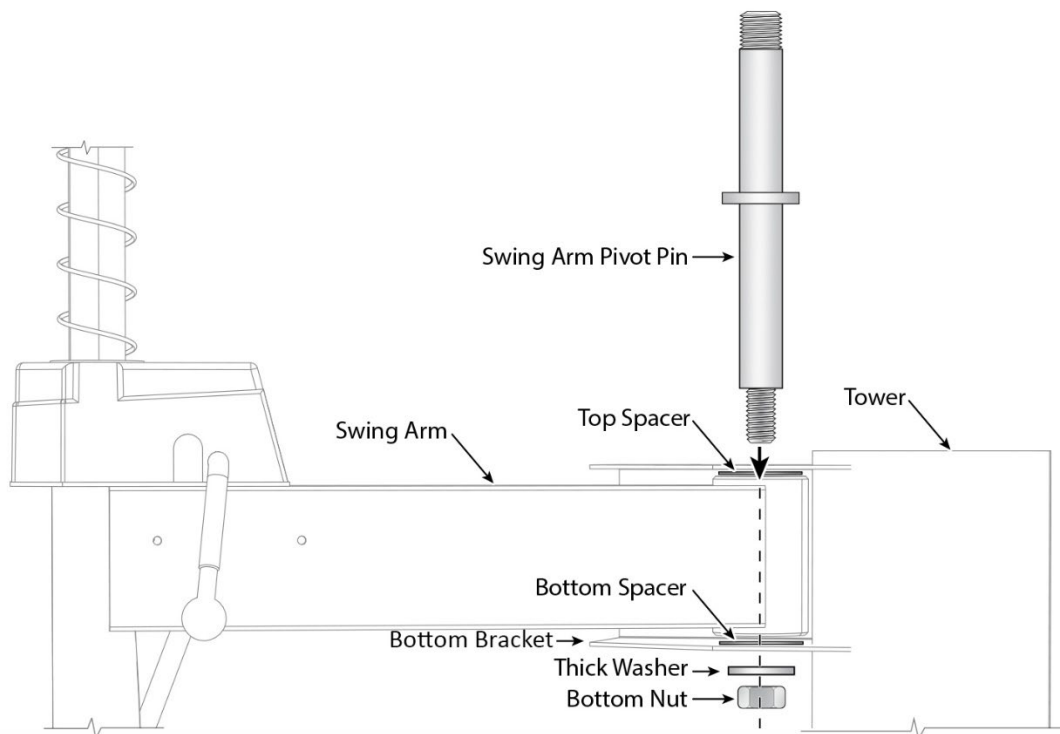

4. Secure the Swing Arm Pivot Pin at the bottom with the Thick Washer and the Bottom Nut.
5. Install the Swing Arm Control into the bracket on the Tower as shown in the illustration to the right.

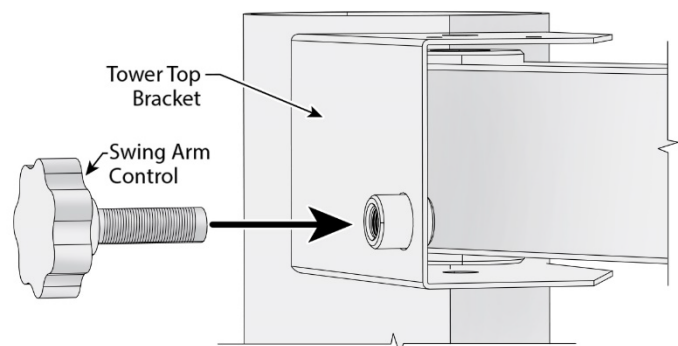

Installing the Assist Arm and Tower Assembly (AT26A only):

1. With the help of a capable assistant, position the Assist Arm Assembly onto the Swing Arm Pivot Pin as shown in the illustration to the below.

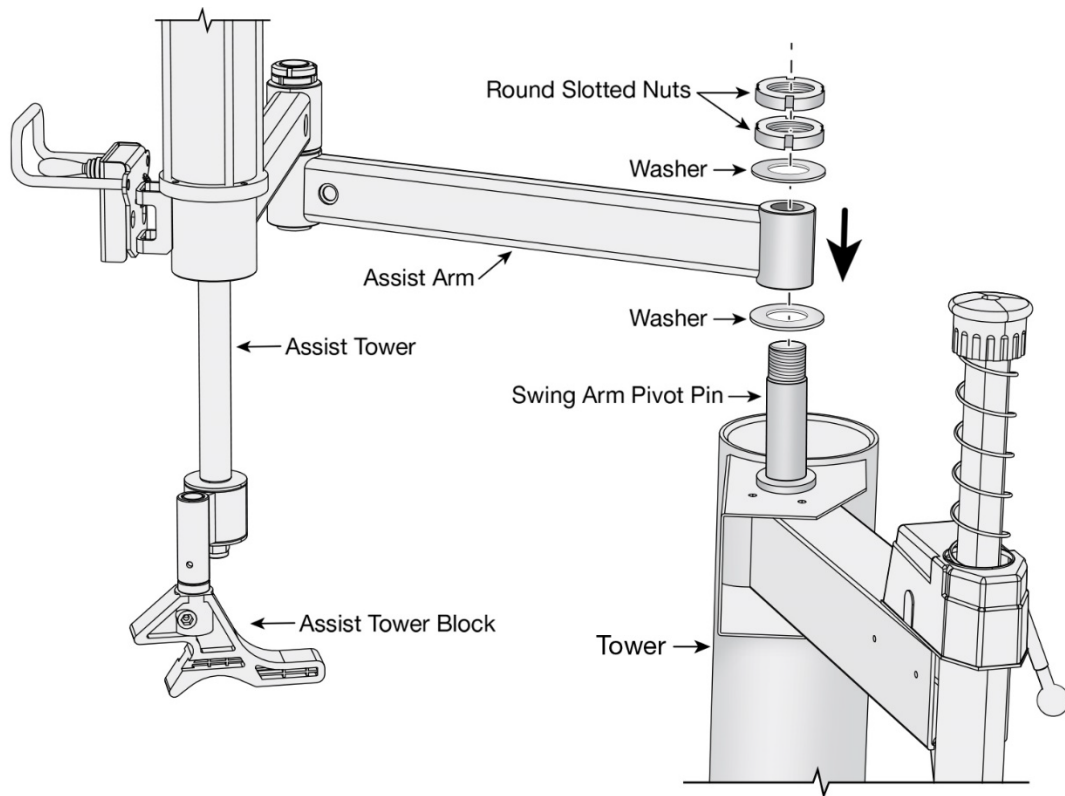

2. Using a Spanner Wrench, tighten both Round Slotted Nuts to Secure the Assist Arm Assembly in place.

Installing the Air Inflation Gun and Hose:

1. Secure the Air Inflation Gun hose to the Air Out Port between the Air Regulator and the Oiler. See illustration to the right.
2. The Air Inflation Gun can then be hung on the hook at the top of the Tower.

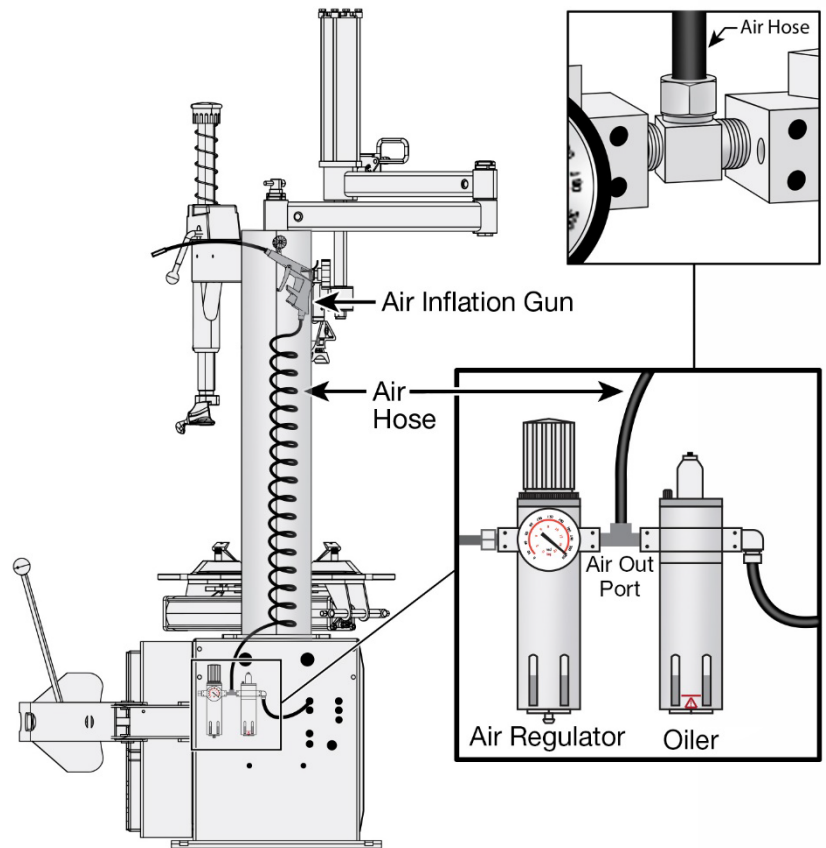

Installing the Bead Breaker:

1. Retrieve the Bead Breaker Blade from its plastic bag.
2. Remove the M14 x 95mm bolt, lock washer and lock nut.
3. Insert the Bead Breaker Blade on to the Bead Breaker Arm and secure with the M14 bolt, lock washer and nut just removed. See illustration below.

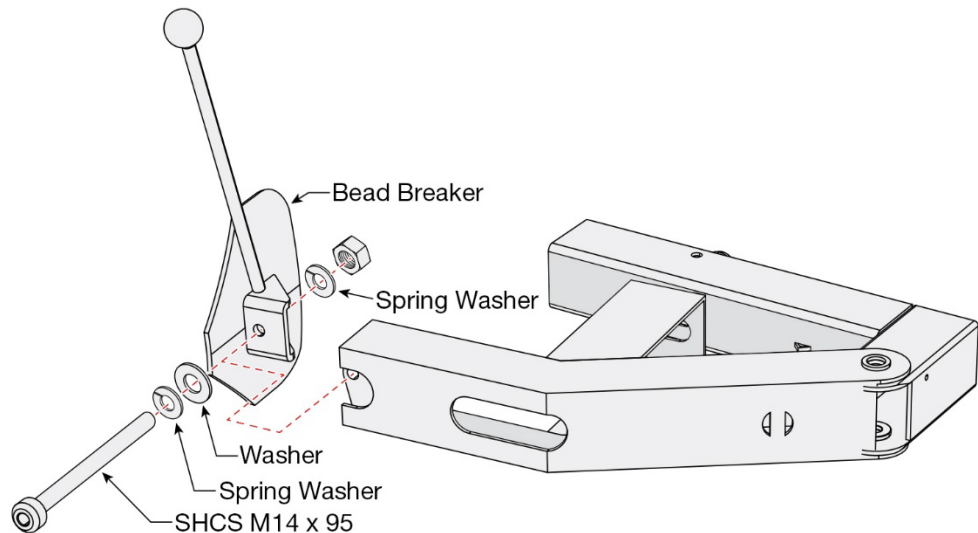

Not to scale. Not all components shown.

Assist Arm Motion Adjustment (AT26A Only)

This section applies to the AT26A only. The AT26A Assist Tower is moved by the operator as required anywhere around the top of the tire. The Assist Tower is supported by the Assist Arm which is connected to the Tower through two adjustable pivot points. One pivot point is located on the Assist Arm and the other is located where the Assist Arm connects to the Tower. The ease with which the Assist Arm moves is controlled by these pivot points through a threaded shaft and two locknuts on each Shaft.

Refer to the illustrations and procedures below.

To Decrease the Assist Arm's resistance to motion:

1. Select the Assist Arm Pivot Point or the Assist Arm Tower Pivot Point.
2. Loosen the Top Lock Nut by one or two turns.
3. Slowly loosen the Bottom Lock Nut while moving the Assist Arm. The resistance to motion should reduce as the nut is loosened.
4. When the Assist Arm's resistance to movement is acceptable, tighten the Bottom Lock Nut.
5. Hold the Bottom Lock Nut in place while tightening the Top Lock Nut to lock the Assist Arm's resistance in the current position.

To Increase the Assist Arm's resistance to motion:

Select the Assist Arm Pivot Point or the Assist Arm Tower Pivot Point.

1. Loosen the Top Lock Nut by one or two turns.
2. Slowly tighten the Bottom Lock Nut while moving the Assist Arm. The Assist Arm's resistance to motion should increase as the bottom lock nut is tightened.
3. When the resistance to movement is acceptable, stop tightening the Bottom Lock Nut.
4. Hold the Bottom Lock Nut in place while tightening the Top Lock Nut to lock the Assist Arm's resistance in the current position.

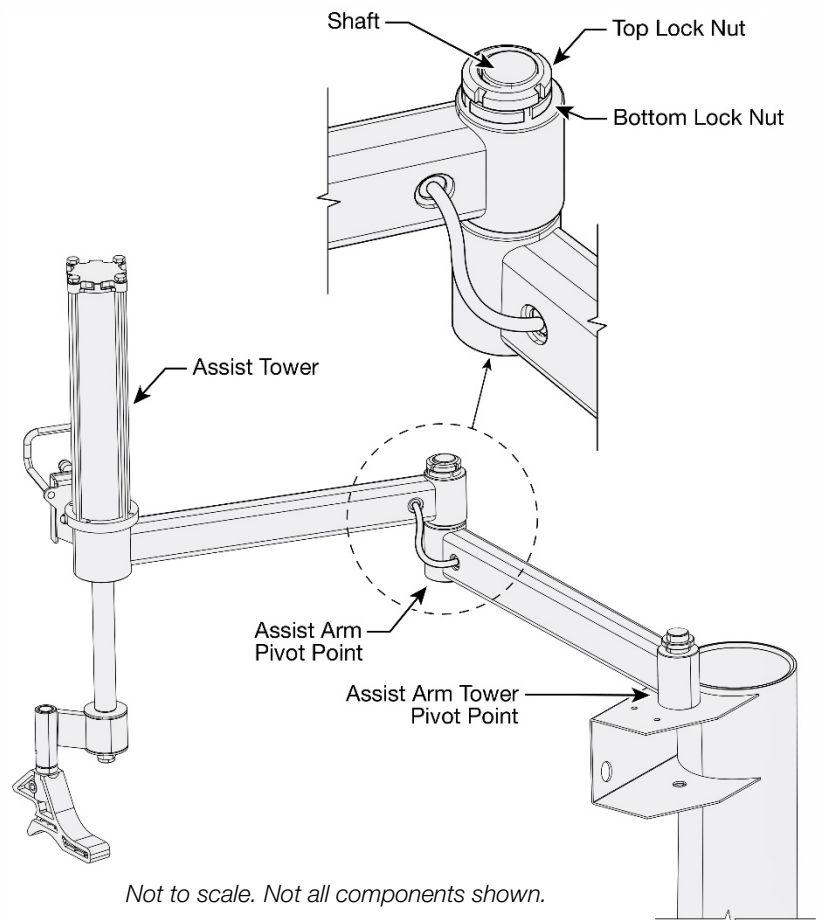

Connecting to Air

The Tire Changer requires a 15 to 25 CFM Air Source with an operating air pressure of 116 to 145 psi (8 to 10 bar). Connect the air source to the **Air In** connector on the Lubricator/Regulator/Filter, located on the back of the Tire Changer.

Important: The Tire Changer uses pneumatic and electrical energy. If the organization has Lockout/Tag-out policies, implement them once the unit is connected to the air source.

The incoming Air Source connects to the Tire Changer via the **Air In** connector on the Regulator/Filter.

Note: A Fitting for the **Air In** connector (1/4 NPT) is **not** supplied and must be provided.

The Quick-Connect Air Fitting (shown to the right, below) connects to the **Air In** connector. The Quick-Connect fitting is **not** supplied with the Tire Changer.

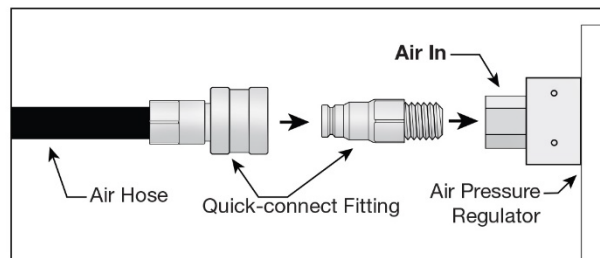
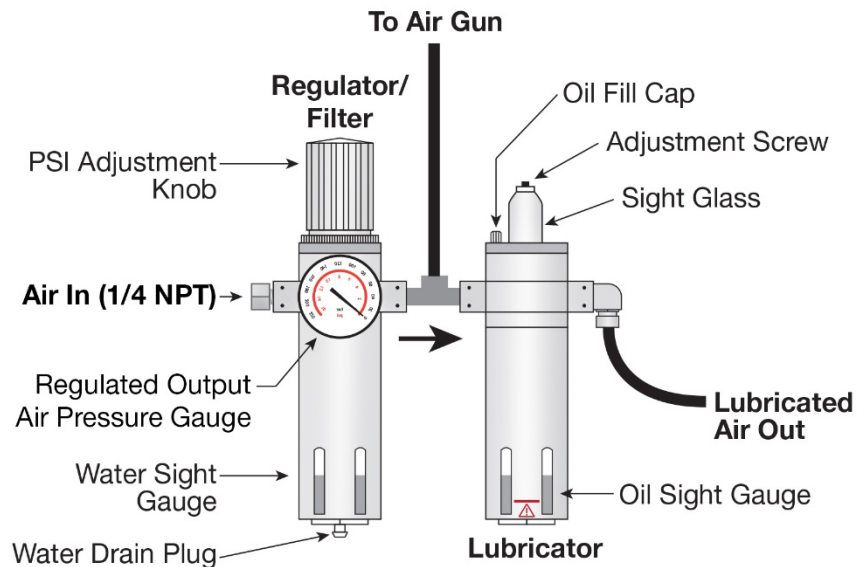

Illustrations not to scale. Not all components

The **Regulator / Filter** removes contaminants from the incoming air. It also includes a gauge that shows the operating air pressure of the incoming air. If there is water in the Water Sight Gauge, it can be drained using the Water Drain Plug. Refer to **Maintenance** for more information.

The **Oiler / Lubricator** puts pneumatic oil, for lubrication, into the incoming air. This lubricated air is routed to pneumatic components of the Tire Changer.

Connecting to Power

The Tire Changer comes configured for a 110 VAC power source. It may be converted to function with a 220 VAC power source, if desired.

⚠ DANGER All electrical work (including changing a Plug from 110 VAC to 220 VAC) must be done by a licensed electrician. If a licensed electrician is not used, the warranty will be voided and everyone who uses the Tire Changer will be put in danger of injury or, in rare cases, death.

Important: The Tire Changer uses pneumatic and electrical energy. If the organization has Lockout/Tag-out policies, implement them once the unit is connected to power.

When delivered from the factory, the Tire Changer is configured for a 110 VAC power source.

- **Plug.** The Power Cord has a 110 VAC plug installed.
- **Voltage Selector Switch.** The Voltage Selector Switch (on the back side of the unit, near the power cord) is set to **110V**. See illustration to the right.

If the Tire Changer is to be connected to a 110 VAC power source, simply plug it in to a 110 VAC power outlet *without changing the setting of the Voltage Selector Switch*. No electrician is needed to use the Tire Changer with a 110 VAC power source as received from the factory.

To convert the Tire Changer to use a 220 VAC power source:

1. Make sure the Tire Changer is **disconnected from the power source**.
2. Cut off the 110 VAC plug on the end of the Power Cord and have a **licensed electrician** attach a 250 VAC, 30A, 2-Pole, 3-Wire, NEMA rated plug. The AT26/26A does not come with this plug and must be supplied separately.

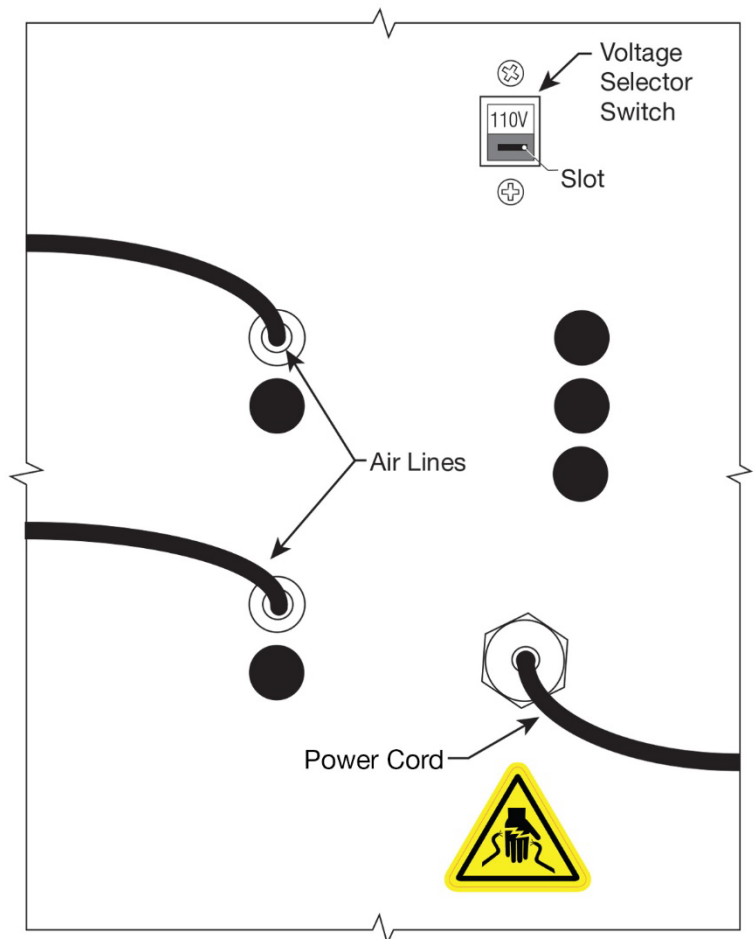

Partial back side view. Not to scale. Not all components shown.

Only a licensed electrician can change the 110 VAC plug to a 220 VAC plug.

The colors of the three exposed wires from the power cord are **Brown**, **Blue**, and **Green/Yellow** (the European color code).

Important: To connect the three exposed wires to an appropriate Plug or to hard wire them, have the electrician follow the electrical codes for the country and locality in which the unit is being used.

For example, if using the unit for 220V in the United States, the color codes of the power cord wiring on the AT26 and AT26A correspond to:

Brown: Live

Blue: Live

Green/Yellow: Ground

When using the unit in a European country, the color codes on the wiring that comes with the AT26/26A corresponds to:

Brown: Live

Blue: Neutral

Green/Yellow: Ground

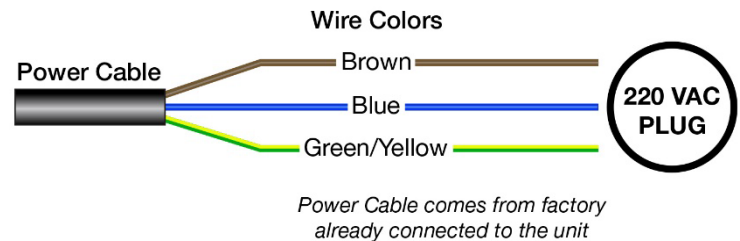

- Information about color code conventions in other regions and countries is available online. Make sure the electrician installs the Plug in accordance with all applicable local electrical codes.
3. Change the setting of the Voltage Selector Switch on the back panel of the Tire Changer to **220V**. This can be done using either a finger or a slot screwdriver.
 4. Double check the Voltage Selector Switch to make sure it is set to the **220V** setting.
- ⚠ CAUTION** The Voltage Selector Switch **must** match the power source. If the unit is plugged into a 110 VAC power source when the switch is set to 220V, or the unit is plugged into a 220 VAC power source when the Switch is set to 110V, the warranty will be voided and severe damage to the Tire Changer may occur.
5. Plug in the Tire Changer to a 220 VAC outlet.
 6. Attach the air source to the Tire Changer.
 7. Test the unit to make sure air and power are working normally.

Additional electrical information:

The Tire Changer Must be Grounded.

Damage caused by improper electrical installation (such as not grounding the unit) voids the warranty.

- ⚠ WARNING** Disconnect power **before** performing **any** troubleshooting or maintenance. Make sure the unit cannot be re-energized until this is done. This equipment has internal arcing or sparking parts that should not be exposed to flammable vapors. The unit must **not** be located in a recessed area or below floor level.

Preparing the Lube Bucket

The Tire Changer comes with a lube bucket and brush.

APEX does not include tire lube with the Tire Changer, as there are many options available.

⚠ CAUTION Only use tire lube that is approved by the tire manufacturer for the tire being changed. Using non-approved lube could corrode the wheel or cause tire/wheel slippage and vibration issues.

Be sure to use enough lubricant without using too much. The point of lubricant is to **temporarily** reduce the friction between the tire bead area and the rim. The lubricant should be slippery when wet but not slippery once dried. If there is an excessive amount of lubricant on the tire or rim, remove the excess.

See the illustration to the right for the location of the lube bucket.

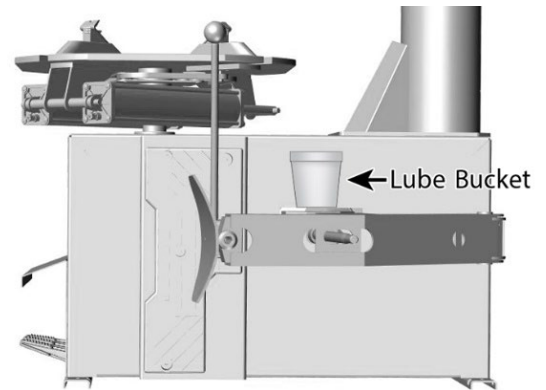

Final Checklist

Make sure the following items have been done **before** putting the Tire Changer into normal operation:

- **Review the Installation Checklist.** Make sure that all of the steps on the **Installation Checklist** have been performed.
- **Check for air pressure.** The Tire Changer requires pneumatic energy to perform certain functions. Ensure that the unit has air pressure by checking the Regulated Output Air Pressure Gauge.
- **Test the power source.** Other Tire Changer functions require electric power. Step down on the Turntable Foot Pedal to check for electric power. If the Turntable turns, there is power.
- **Check the Anchor Bolts.** If the Tire Changer is bolted down, make sure the Anchor Bolts are in position and tightened down.
- **Make sure there is Tire lubricant available.** The shop probably has a brand of Lube that it prefers. Make sure some is in the Lube Bucket on the Tire Changer. Always use Lube; it makes changing tires easier and helps prevent damage to the tire and the wheel.
- **Change some non-customer Tires.** To get familiar with the Tire Changer, APEX recommends having all potential Operators change *multiple non-customer* tires before working on customer Tires.

Leave the Manual with the owner/operator. Deliver the Installation and Operation Manual to the owner/user/employer along with any other instructional materials furnished with the Tire Changer. The manual should be kept near the Tire Changer at all times.



Operation

This section describes how to use the APEX AT26/26A Tire Changers.

It details and describes the main components involved in demounting and mounting tires, followed by the necessary procedures for each step in the process.

⚠ DANGER Being in close proximity to a Tire Changer is a serious endeavor with potentially life-threatening risks. Only trained, authorized, and supervised personnel may be within 30 ft. (9.14 m) of the Tire Changer while it is in use.

Usage Precautions

Keep the following in mind while using the Tire Changer:

- Make sure all Operators receive specific training in Tire demounting and mounting **before** they are allowed to use the Tire Changer, that their training is verified through a testing program, and that all training is documented. All others, including children and untrained personnel, **must** be kept at least 30 ft. (9.14 m) away from the Tire Changer while it is in use.
- Make sure new Operators are trained and supervised in the use of the Tire Changer.
- Never perform any service on an *inflated* tire; **always** fully deflate the tire by removing the Valve Core and letting the air escape before beginning work.
- Never mount or change **damaged** tires or wheels.
- When mounting tires, identify the maximum allowed inflation pressure; it should be marked on the sidewall of the tire. **Do not exceed the maximum allowed inflation pressure of the Tire.**
- Make sure the tire is restrained for inflation by either internally clamping or in a Tire Inflation Cage (such as the **RIC-4716 4-Bar Tire Inflation Cage from Apex**). **Do not inflate a tire if it is externally clamped; external clamping interferes with inflation.**
- When using the Tire Changer, be careful of the multiple pinch point dangers on the unit. **Do not rest hands on any part of the Tire Changer while using it.**

⚠ WARNING The Air Chuck has a self-gripping clip which allows it to clip on the valve stem when inflating a tire, which means it does not need to be held in place during inflation. **Do not hold the Air Chuck while inflating a tire.**

- All operators **must** wear OSHA-approved (publication 3151) Personal Protective Equipment at all times when installing, using, maintaining, or repairing the Tire Changer. Leather gloves, steel-toed work boots, eye protection, back belts, and hearing protection **are mandatory**.
- When using the Tire Changer, the operator must wear **ANSI-approved** eye protection at all times: safety glasses, a face shield, or protective goggles.

⚠ WARNING Always wear ANSI-approved eye protection. An accident could cause significant eye injuries.

- The Tire Changer may work differently than other Tire Changers previously used. APEX recommends that operators practice on multiple non-customer tires to get familiar with how the product works *before* starting work on customer tires.
- Keep the work area clean and well lit. Dirty, cluttered, and dark work areas increase the chances of an accident occurring.
- Do not access the inside of the unit unless instructed to do so by APEX Support.

⚠ DANGER Be especially careful when inflating tires. Inflation is a dangerous operation. If the tire and wheel are mismatched or there is a defect in the tire, it could explode, injuring or killing the Operator or bystanders. **Do not lean over the tire while inflating it.**

- Do not use the Tire Changer in a wet environment or expose it to rain or excess moisture.
- If an extension cord is needed to get power to the unit, use one with a current rating equal to or greater than that of the Tire Changer. Cords rated for less current than the Tire Changer could overheat. If used, arrange the extension cord so that it will not be tripped over or pulled out.
- Do not use anything flammable on the Beads or Rims as lubrication. Use non-flammable vegetable or soap-based rubber lubricant.
- Do not use the Tire Changer in the vicinity of open containers of flammable liquids.
- Clean the unit according to the instructions in **Maintenance** section.
- Read the **entire** *Installation and Operation Manual* **before** using the Tire Changer.
- Make a visual inspection of the Tire Changer **before each use**. Do not operate the Tire Changer if any issues are found. Instead, take it out of service and contact the dealer, visit www.Bendpak.com/support, or call APEX at **(877) 432-6627**.
- Always identify and correctly match the tire and rim diameters of the tires being mounted; **they must match exactly**. If they do not match exactly, this is called a tire mismatch. The result of a mismatch is that the tire could literally explode off the wheel when inflated or while the vehicle is being driven. In both cases, people could be injured or killed.

The phrase “tire mismatch” is also used to mean tires on a single vehicle with different tread patterns or from different manufacturers. This is different than what is being described above.

More information is available in OSHA standard 29 CFR 1910.177 (Servicing Multi-Piece and Single Piece Rim Wheels). **All operators should study this document prior to servicing any Tires.**

Turntable

The turntable is where the wheel/tire is positioned for mounting/de-mounting.

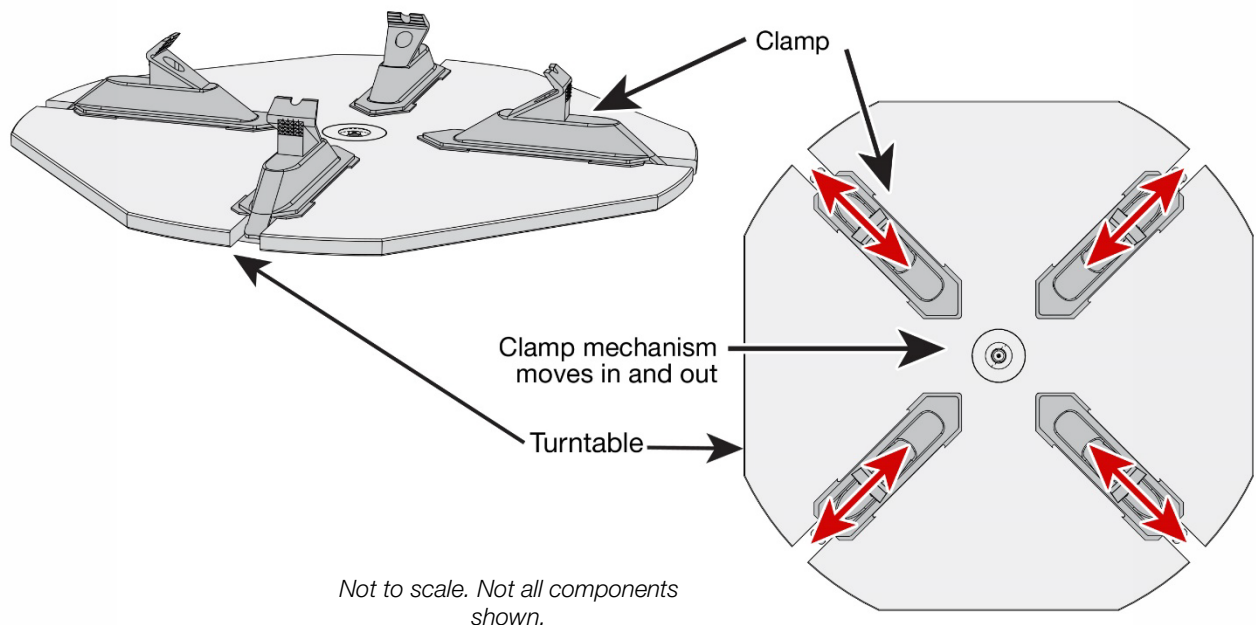

The turntable can rotate either clockwise or counterclockwise.

- **To rotate clockwise:** Press **Down** the Turntable Foot Pedal.
- **To rotate counterclockwise:** Press **Up** the Turntable Foot Pedal.
- **Clamp Mechanism.** The Clamp Mechanism moves in and out to clamp wheels either externally or internally. All four Clamp Mechanisms move together. They can all be in or they can all be out. “External” and “Internal” clamping refer to the location of the Clamp in relation to the wheel.

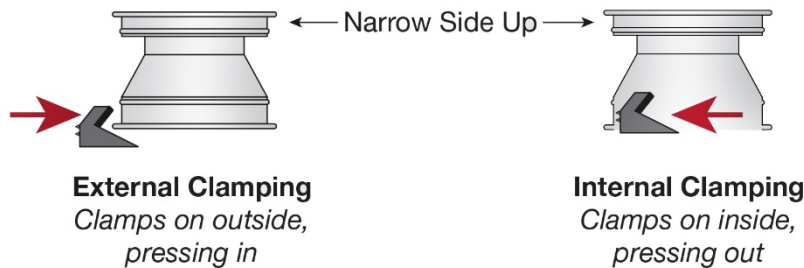

Side view. Some components exaggerated for clarity. Large arrows show direction Clamps are pressing. Only one of the four Clamps shown. Not to scale. Not all components shown.

As a general rule, steel wheels are clamped internally (clamps push out against wheel) and custom and mag wheels are clamped externally (clamps push in against outside rim edge). **Check with a supervisor if it is unclear about which method to use for a particular set of wheels.**

To clamp externally. If necessary, press **Up** on the Clamps Foot Pedal to move the Clamps **Out**. The clamps may be all the way out already, in which case they do not need to be moved.

Then, position the wheel between the Clamps and press **Down** on the Clamps Foot Pedal to move the Clamps **In** until the wheel is being held firmly on the Turntable.

To clamp internally. If necessary, press **Down** on the Clamps Foot Pedal to move the Clamps **In**. The clamps may be all the way in already, in which case they do not need to be moved.

Then, position the wheel over the Clamps and press **Up** on the Clamps Foot Pedal to move the Clamps **Out** until the wheel is being held firmly on the Turntable.

Pedal Function

The Tire Changer has three foot pedals that control the Tire Changer actions:

- **Turntable Foot Pedal** rotates the Turntable. Press and hold **Down** the Turntable Foot Pedal to rotate clockwise, press and hold **Up** the Turntable Foot Pedal to rotate counterclockwise. When the Turntable Foot Pedal is released, the Turntable stops moving.
- **Clamps Foot Pedal**. Press **Down** to move the Clamp Mechanisms inward towards the center of the turntable. Press **Up** to move the clamps outwards away from the center of the turntable.
- **Bead Breaker Foot Pedal**. Press **Down** to move the Bead Breaker Blade in toward the Tire Changer. Release the pedal to move the Blade back out.

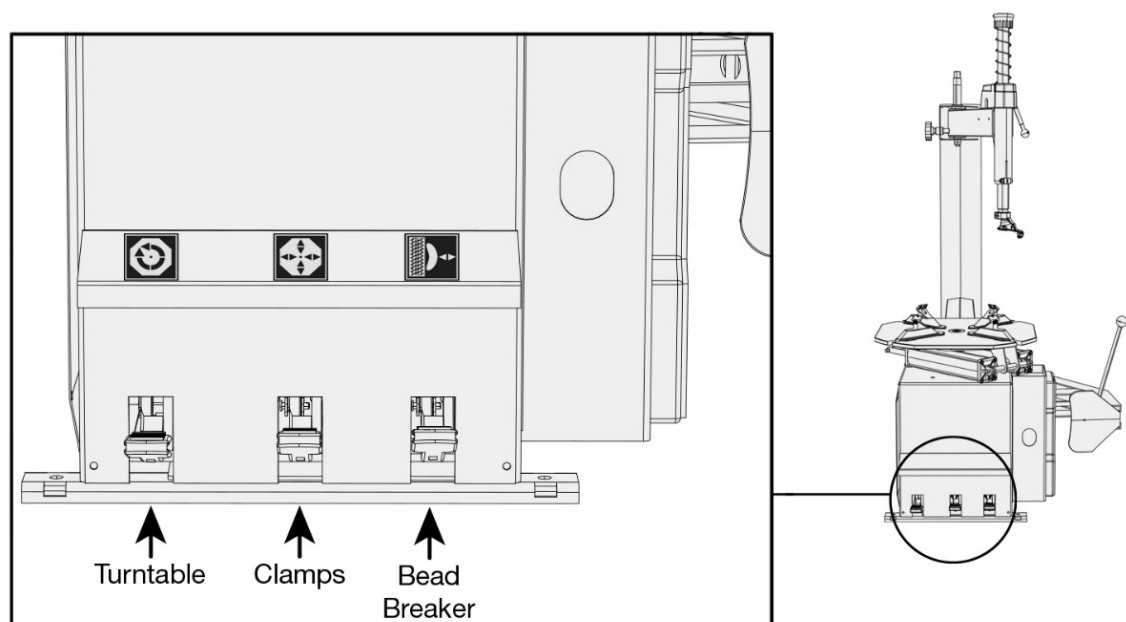

Not to scale. Not all components shown.

Air Inflation Gun, Gauge and Air Chuck

The Inflation Gauge displays the air pressure in the tire to which the Air Chuck is attached.

- **Air Chuck.** Attaches to the threads on a tire's Valve Stem and includes a self-gripping clip so the Air Chuck does not need to be held in place during inflation.
- **Inflation Gauge.** Displays air pressure in the tire to which the Air Chuck is attached.
- **Pressure Release Valve.** Releases air from a tire.

⚠ WARNING *Do not hold the Air Chuck while inflating a Tire.* This leaves the operator too close to the tire, which could result in injury if there is a problem during inflation.

To see the pressure in a tire: Attach the Air Chuck to the tire's valve stem. The Inflation Gauge displays the air pressure currently in the tire.

To see pressure during tire inflation: Attach the Air Chuck to the tire's valve stem, move away from the tire, then squeeze the Air Inflation Gun Trigger to inflate the tire. The Inflation Gauge displays the air pressure in the tire as it inflates.

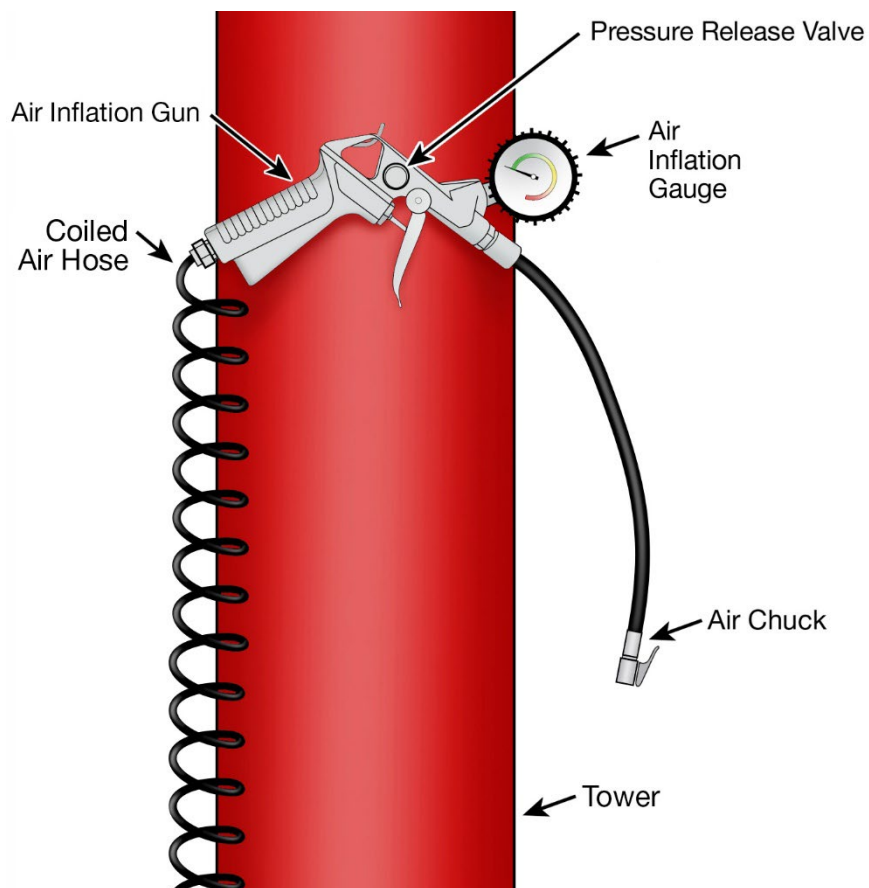

Not to scale. Not all components shown.

Swing Arm

The Swing Arm holds the main Tire Changer tool, the Mount/Demount Head. It swings out of the way to the right when not needed or when it is in the way.

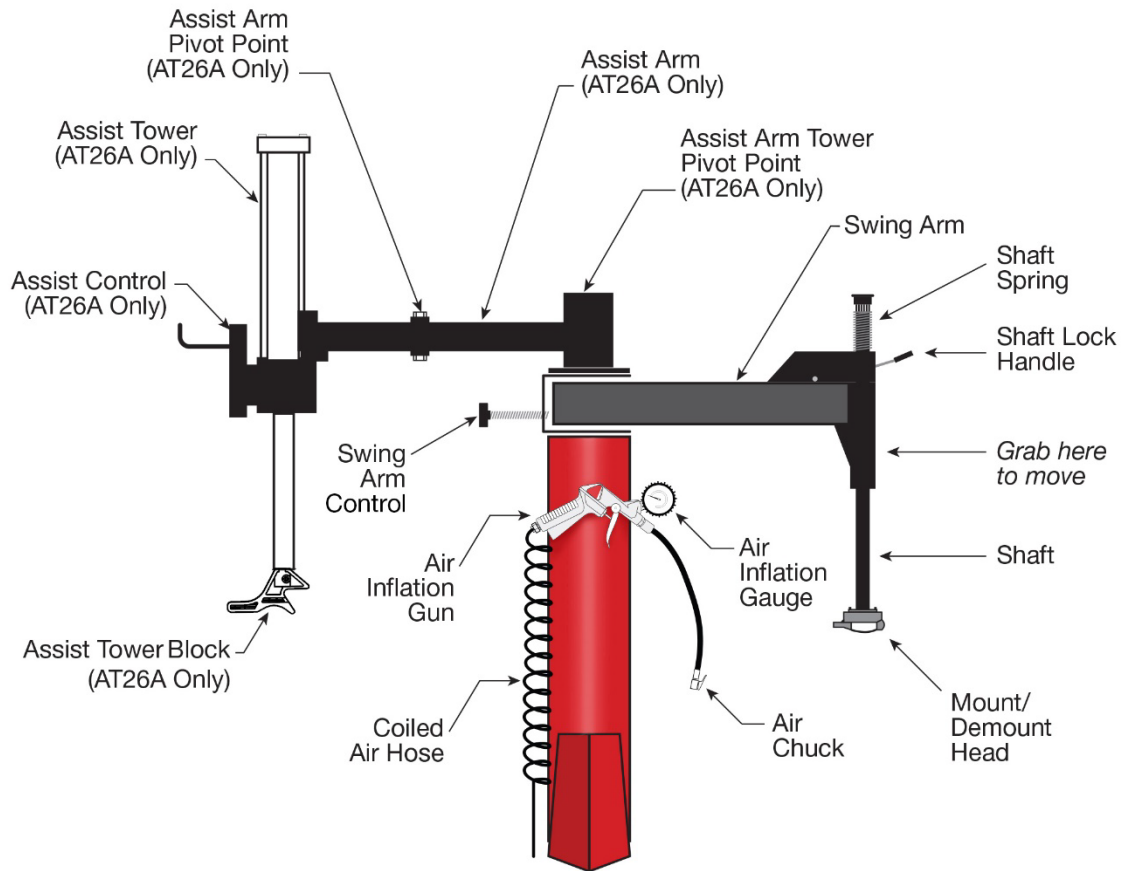

Front view. Swing Arm shown fully to the right. Not to scale. Not all components shown.

The main parts of the Swing Arm are:

- **Swing Arm.** When facing forward, puts the Mount/Demount Head directly over the middle of the Turntable. From that position, the Swing Arm can swing up to 90° to the right, which allows it to move out of the way when not needed.
- **Swing Arm Control.** Limits how far the Swing Arm can move back, which lets it be positioned in a desired location. This is useful when working on multiple wheels that are the same size: move the Mount/Demount Head to the desired location, then adjust the Swing Control so that the Swing Arm returns to this same position if moved out and then back.
- **Mount/Demount Head.** Demounts and mounts tire beads.
- **Shaft.** Moves the Mount/Demount Head up and down. Use the Shaft Cap to move the Shaft down. Do not grab the Shaft itself; it is greased.
- **Shaft Cap.** Moves the Shaft down; it moves back up automatically via the Shaft Spring.
- **Shaft Lock Handle.** Locks the Shaft in position.
- **Shaft Spring.** Automatically moves the Shaft and the Mount/Demount Head back up when releasing the Shaft Lock Handle.
- **Moving the Swing Arm.** Grab the section of the Shaft housing just under the Swing Arm to move the Swing Arm left and right. Do not move the Swing Arm using the Shaft or the Shaft Spring.

Mount/Demount Head

The Mount/Demount Head is the main tool on the Tire Changer for demounting and mounting tires.

The following drawing shows the Mount/Demount Head with the Demount and Mount Lips identified. It also shows where the tire bead rides during demounting and mounting.

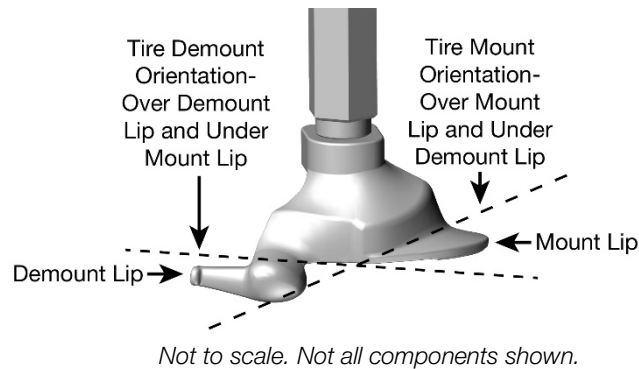

The Demount Lip and Mount Lip work as follows:

- **During demounting.** The tire bead goes **over the Demount Lip** and *under the Mount Lip*.
- **During mounting.** The tire bead goes **over the Mount Lip** and *under the Demount Lip*.

The Mount/Demount Head that comes with the Tire Changer is alloy steel, which includes plastic inserts on the inside to avoid damaging rims. Replace the plastic inserts after two months of use, or as required. See the [Maintenance](#) section.

Alternatively, a plastic Tool Head and mounting flange are available. See the [accessories page](#) on the BendPak website.

Tire Compression Roller

The Tire Compression Roller is a bolt-on attachment to the Mount/Demount Head. Prior to mounting the top bead, swing the compression roller into position and tighten the socket cap hex screw to secure it.

When mounting the top tire bead, the Tire Compression Roller will provide additional downward force on the bead, guiding it onto the wheel.

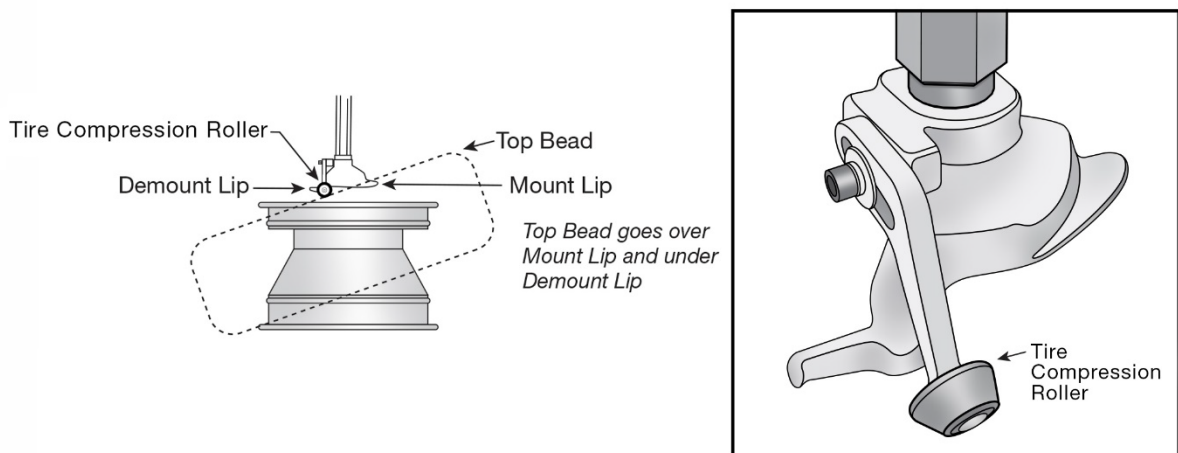

Assist Tower and Arm (AT26A Only)

This section applies to AT26A only. The Assist Arm supports the Assist Tower which holds two different Tools to assist in the dismounting, mounting, and inflation of tires.

The Assist Tower may be moved manually around the tire. The Assist Tower may also be moved up and down using the pneumatic control on the Tower.

The components of the Assist Tower are:

- **Assist Arm.** Supports the Assist Tower and Control.
- **Control.** Used to move the Assist Tower up and down.
- **Assist Tower.** Consists of a pneumatic cylinder, its control, and tools.

There are two tools that may be attached to the Assist Tower:

- **Assist Tower Block.** Used to hold down the Top Bead during the mounting/demounting process.
- **Restraint Tool.** This tool slides onto the Assist Tower Block and is used in two ways. First, when clamping a tire with hard sidewalls for demounting, use the Restraint Tool to push the wheel down firmly against the Turntable. Pushing the rim against the turntable aides in external clamping. Second, when inflating a tire, use the Restraint Tool to hold the wheel in position.

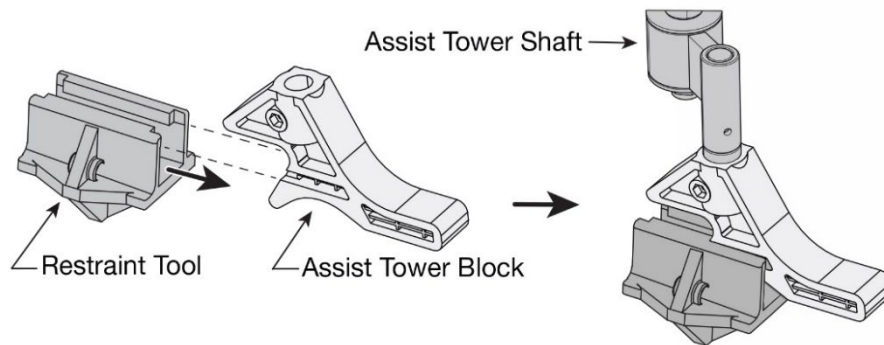

Using the Assist Tower (AT26A Only)

This section applies to AT26A only.

- The Assist Tower is moved into position manually, then the tool is lowered using the pneumatic toggle switch on the tower as shown to the right.
- Push the toggle **down** to lower the tool to the tire.
- Push the toggle **up** to raise the tool away from the tire.

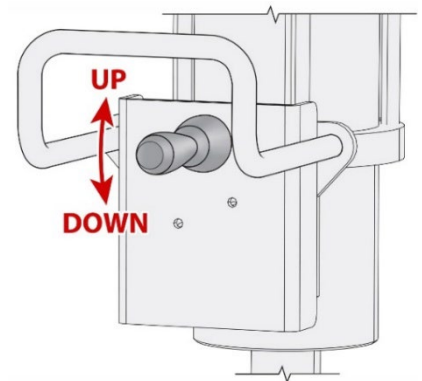

- The Assist Tower provides additional downward pressure on the tire wall to aid in placing the bead lifting tool between the rim and the tire and then ease the bead over the mount/demount head.
- The Assist Tower may also be used to pry out hard tire beads. The tire compression head can be used to press the tire bead opposite the Changer Head. See illustration to the right.

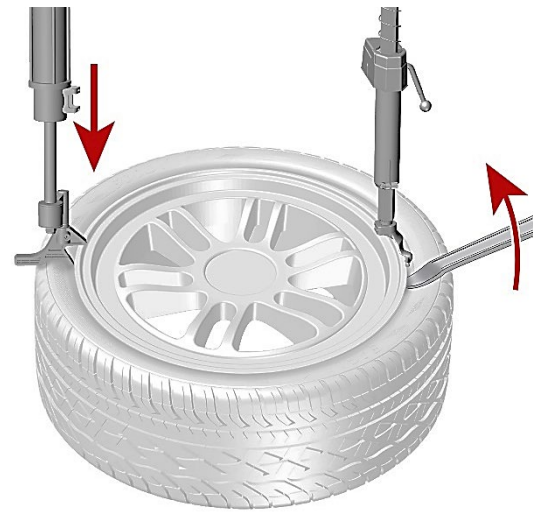

- The Assist Tower can be used to push down on the top bead, while the Tire Mount/Demount Head uses a Tire Compression Roller. The compression roller presses down on the top bead and guides the upper tire bead into the Bead Seat (groove) of the wheel. See illustration to the right.

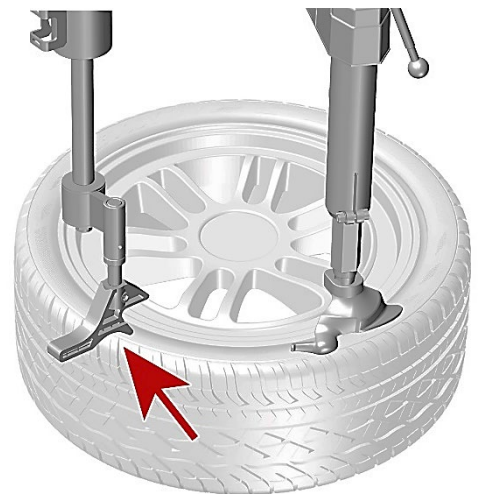

- When mounting tires with hard sidewalls, use the Assist Tower with the Restraint Tool attachment to press down on the tire to assure a firm external grip from the turntable clamps. The Restraint Tool may also be used to hold the wheel in place during tire inflation. See illustration to the right.

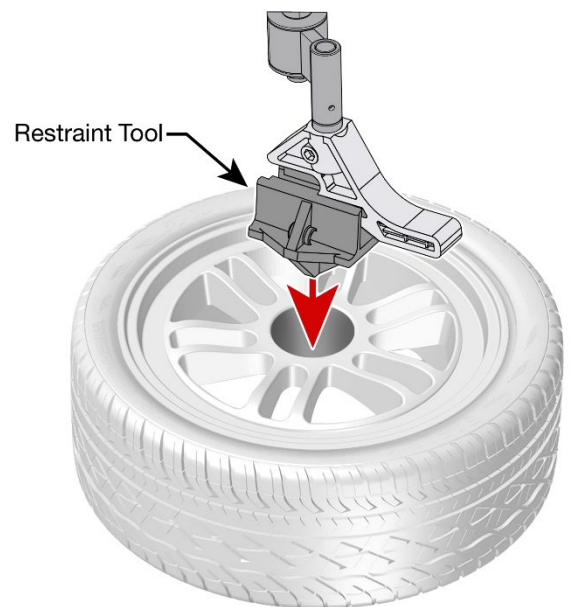

Bead Breaker

Use the Bead Breaker to break the beads (on both sides) of the tires being demounted.

⚠ WARNING ***Do not break the beads of a tire until it is certain that it has been fully deflated.*** Breaking the bead of a tire with air still in it could injure the operator or others nearby. The best way to be sure the tire is fully deflated is to remove the valve core and wait for all of the air to escape.

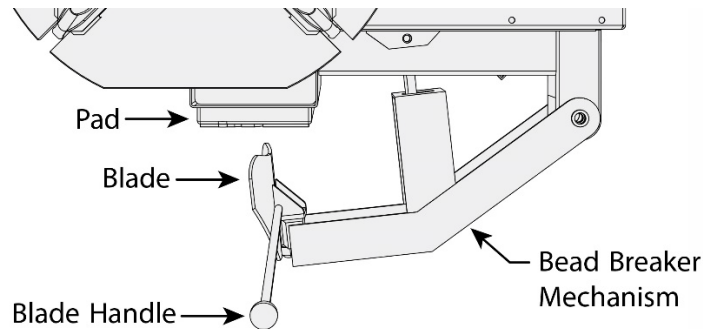

Top view. Not to scale. Not all components shown.

⚠ WARNING ***There is a risk of a crushing injury with the Bead Breaker.*** Keep hands, feet, body, and loose clothing clear of the blade. Do not hold onto the Blade Handle when the Bead Breaker is moving. After positioning the Bead Breaker Blade using the Handle, move away from the Bead Breaker, and make sure the area is completely clear, **before** pressing down on the Bead Breaker Foot Pedal.

The main parts of the Bead Breaker are:

- **Bead Breaker Mechanism.** Moves in and out under the control of the Bead Breaker Foot Pedal. It moves with great force, so it is important to make sure operators are completely clear of the Blade and the Bead Breaker Mechanism **before** depressing the Bead Breaker Foot Pedal.
- **Blade.** The part of the Bead Breaker that contacts the tire and actually breaks the bead. Make sure to keep the Blade on the tire and slightly off the wheel rim. Caution should be used as the Blade can cause damage to the wheel.
- **Blade Handle.** Controls the Blade, moving it side to side and in and out.
- **Pad.** The side of the tire whose bead is **not** being broken goes against the pad mounted to the side of the Tire Changer.

Bead Lifting Tool

The Bead Lifting Tool is a hand tool, used to pull the tire's bead up and over the Mount/Demount Tool when demounting a tire.

The Bead Lifting Tool can be used to push down the tire's bead (located to the left of the Mount/Demount Head) during the mounting of a tire.

The Bead Lifting Tool has an angled and a hooked end. Either end can be used.



Before Changing a Tire

⚠ DANGER Do not allow operators to use the Tire Changer unless they have been properly trained and have read the entire *Installation and Operation Manual*. Tire changing must only be done by trained, authorized, supervised personnel. **Failure to understand and follow proper procedures will result in injury or death.**

Before changing a tire:

- **Remove existing weights.** Check the wheel to make sure that all existing clip-on and adhesive weights have been removed.
- **Deflate the Tire.** This is required. **Tires must be fully deflated before demounting.** To make sure a Tire is *fully deflated*, remove the Valve Core from the Valve Stem and then wait for all of the air to come out. A valve core tool can be used for this procedure to prevent damage to the core or stem.
- **Have Tire lubricant ready.** Tire lubricant makes the process of demounting and mounting tires much easier. Not using tire lubricant significantly increases the chances of damaging the wheel and the tire. Tire lubricant is not provided with the Tire Changer.
- **Check for damage.** Especially with expensive wheels, make sure to check them for any damage *before* changing the tire. Depending on the circumstances, any damage found should be discussed with the owner of the vehicle. It is important to understand shop policies in this area. Additionally, damaged wheels and tires are dangerous to work with. When unsure about whether a wheel or tire is too damaged to service, talk to a supervisor.
- **Understand Custom Wheels.** Before servicing performance wheels, review the **Custom Wheels** section of this manual.
- **Identify the Narrow Side/Drop Center of the Wheel.** The rule is: the Narrow Side/Drop Center side of the wheel gets put onto the Tire Changer facing up. For most wheels, this means the side of the wheel facing the *outside* of the vehicle goes on top, because that's where the Narrow Side/Drop Center side is on most (but not all) wheels.

The following drawing shows two wheels and identifies the Narrow Side, Drop Center, and Wide Side of each.

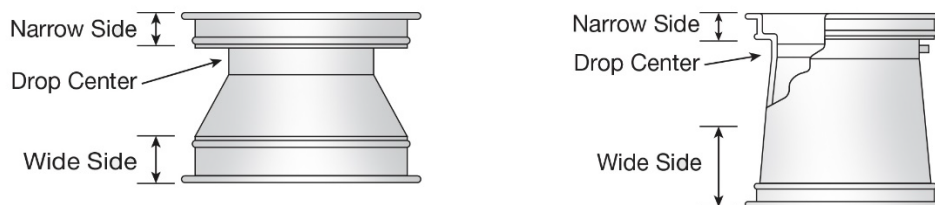

Some aftermarket and OEM performance wheels are **reverse** drop-center wheels, meaning the Narrow Side/Drop Center side of the wheel is closer to the *inside* of the vehicle. The rule still holds for these vehicles: the Narrow Side/Drop Center side of the wheel gets put onto the Tire Changer facing up.

- **Ask the Supervisor.** If there are any concerns about a tire or wheel, or about how to use the Tire Changer, talk with a supervisor **before** starting work.

Working with Custom and Special Wheels

This section covers working with alloy wheels with no drop center, European performance wheels, and wheels with tire pressure monitoring systems.

Alloy Wheels

Some manufacturers offer wheels with little or no drop center. These types of wheels are almost never Department of Transportation (DOT) approved.

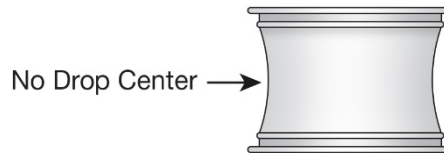

⚠ DANGER The tire, wheel, or both can be damaged and the tire could explode under pressure, resulting in serious injury or death. **APEX recommends not trying to demount or mount this type of wheel.** If an attempt is made to demount or mount this type of wheel, **proceed with extreme caution.**

European Performance Wheels

Some European performance wheels have very large humps except near the valve hole.

On these wheels, the beads should be loosened at the valve hole on both the upper and lower sides first.

Wheels with Tire Pressure Monitoring Systems (TPMS)

Some wheels have a pressure sensor located behind the valve stem. On these wheels, the beads should be broken opposite the valve stem on both upper and lower sides first, before breaking the beads on the rest of the tire.

Performance wheels on some vehicles have a pressure sensor strapped to the rim opposite the valve hole. On these wheels, the beads should be loosened at the valve hole on both the upper and lower sides first, before breaking the beads on the rest of the tire.

Be mindful of the TPMS sensor when breaking a tire's bead, demounting a tire, and mounting a new tire. If the shop does not have specific recommendations for handling these situations, APEX recommends:

- **When breaking a tire's bead.** Keep the TPMS sensor away from where the bead is being broken. Put the sensor at 12 o'clock high (relative to the ground) when breaking the bead.
- **When demounting a tire.** Put the TPMS sensor just to the **right** of the Mount/Demount Head.
- **When mounting a tire.** Put the TPMS sensor just to the **left** of the Mount/Demount Head.

These are general guidelines. Use common sense and take into consideration the specifics of each situation. Talk to a supervisor if there are any questions or safety concerns.

When completing a tire mounting with a TPMS sensor, check that it is working. **It is against the law to knowingly re-install a non-functional TPMS.** If the vehicle came in with a functioning TPMS, it needs to leave with a functioning TPMS.

The Steps in Changing a Tire

Before starting to work on a tire, review the requirements in [Before Changing a Tire](#).

Changing a tire consists of multiple steps:

1. **Deflate the Tire.** There is a lot of energy stored in a tire when it is inflated. The tire must be fully deflated before it can be demounted. If not, that energy will be released during demounting, which could result in the tire exploding, causing injury and even death to the operator and bystanders. ***Never work on a tire unless it has been personally confirmed that it is fully deflated.*** The best way to do this is to make sure the valve core has been removed from the valve stem and the air has had time to come out.
2. **Break the Bead.** Tires stay in position on the wheel because the tire bead is seated between the bead retainer and the rim lip of the wheel (called the bead seat). To demount a tire, the bead must be removed from the bead seat—all the way around ***both sides*** of the tire. This is called breaking the bead. Use care when breaking the bead of wheels with a Tire Pressure Monitoring System (TPMS).
3. **Secure the Wheel on the Turntable.** It is important for the wheel to stay in place on the Turntable. The tire changer supports both internal and external clamping.
4. **Demount the Tire.** Once the bead is broken, slide both beads over the rim lip of the wheel to remove it fully. Once the tire is demounted from the wheel, it can be moved out of the way to make room for installing the new tire.
5. **Mount the Tire.** Mounting a tire is basically the opposite of demounting. The first step is to get the beads under the rim (the opposite of demounting the tire), get the beads positioned in the bead seats (the opposite of breaking the bead), and then inflate the tire.
6. **Inflate the Tire.** There are three separate stages to inflation: Bead Seal, Bead Seat, and Inflate. **Bead Sealing** is putting in a small amount of air pressure to push the tire up against the rim so that no more air leaks out. **Bead Seating** is putting in more air pressure to “pop” the beads into position in the Bead Seats. **Inflation** is adding air pressure to the tire manufacturer’s recommended pressure after the beads have been seated.
Important: Do not inflate a tire if it is externally clamped; external clamping interferes with inflation. Move the Clamps away from the tire and use a [Tire Inflation Cage such as the RIC-4716](#). If using the AT26A, the Assist Tower with the Restraint Tool may be used to secure the tire on the Turntable before inflating.
7. **Remove the Wheel from the Turntable.** Disengage the Clamps, then move the wheel and tire off the Turntable and back onto the ground.

About Valve Stems

The illustration to the right shows a valve stem and its components.

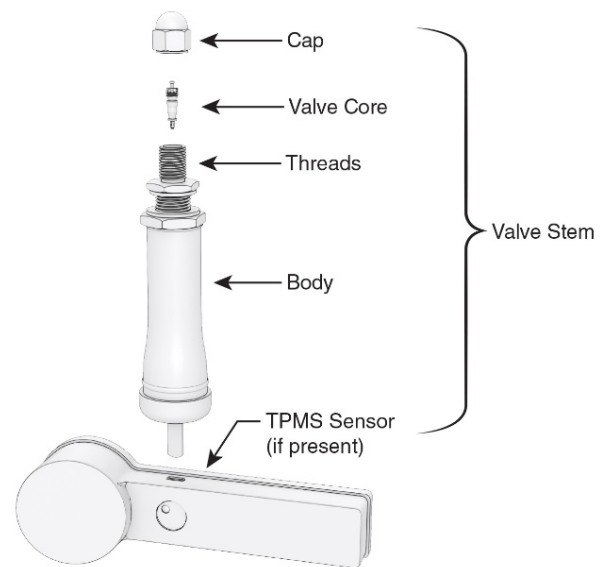

- **When demounting a Tire.** Taking out the valve core lets the air out of the tire, which **must** be done before it can be demounted.

⚠ DANGER It is dangerous to do any service on a tire if there is air in it.

Use a valve core tool to remove a valve core. Don't risk damaging the core or stem by using the wrong tool.

- **When to replace the entire Valve Stem.** Valve stems are normally replaced when mounting a **new** tire.

When mounting a new tire, APEX recommends installing a new valve stem, but it is not required. The process for replacing a valve stem is to cut out or pull out the old valve stem, then install the new valve stem. This should be done after the old tire has been demounted but before the new tire is mounted.

Use a Valve Stem Installer/Remover Tool (sometimes called a Valve Stem Puller/Remover Tool) that can be used to both remove an old valve stem and install a new valve stem.

This tool is **not** the same tool as the Valve Core Tool.

- **When inflating a Tire.** Before starting the first stage of inflating a tire (sealing the beads), remove the Valve Core. **Make sure to keep it.** Removing the Valve Core allows air to move more easily into the tire.

Once the *second* stage of inflating a tire (seating the beads) is *complete*, put the Valve Core back in.

The first two stages, sealing and seating the beads, do not require too much air pressure. The third stage, inflating the tire, does. Have the replacement Valve Core close at hand for the inflation stage, as that will keep too much air from coming back out of the tire.

Once the replacement valve core is installed the tire can be inflated to its recommended pressure.

Deflating a Tire

A tire must be fully deflated before demounting it.

 **DANGER** Never attempt to demount or mount an *inflated* tire. **It must be deflated.** Attempting to demount or mount an inflated tire could cause it to explode, which could result in injury or even death.

Deflating a Tire:

1. If the valve stem has a cap on it, remove the cap.
2. Remove the valve core from the body.
3. Use a valve core tool to remove the valve core. Do not risk damaging the valve core or the stem by using the wrong tool.

APEX recommends installing a new valve stem when mounting a new tire.

4. Make sure all of the air comes out of the tire.

 **WARNING** Do not proceed with any other tire changing activity until it is certain the tire is **fully** deflated. When demounting a tire, **the operator** must make sure it is **fully deflated**.

Breaking the Beads

The beads must be broken on both sides of a tire before it can be demounted.

⚠ WARNING Do not break the bead of a tire until ***it is certain that the tire is fully deflated***. A tire with air still in it could explode, injuring the operator or bystanders.

The bead is broken when the tire beads come out from between the rim lip and the bead retainer (the bead seat) all the way around the tire, on ***both*** sides.

To Break a Tire's Beads:

1. Make sure operators are wearing OSHA-approved (publication 3151) Personal Protective Equipment: leather gloves, steel-toed work boots, back belts, hearing protection, and ANSI-approved eye protection (safety glasses, face shield, or goggles).
2. Check the tire again to make sure it is ***fully*** deflated.
3. Check both sides of the tire to make sure all wheel weights (from previous balancing) have been removed. If they have not, remove them.

⚠ CAUTION Breaking the beads of a tire with wheel weights could damage the Tire Changer and/or the wheel.

4. Identify the ***narrow*** side of the tire whose beads being broken. Break this side first.
5. Move the tire into position between the Pad and the Bead Breaker Blade, with the ***narrow*** side of the tire on the blade side.
6. When breaking the beads of a tire with a Tire Pressure Monitoring System (TPMS), put the sensor at 12 o'clock high or 6 o'clock low (relative to the ground), to reduce the chances of damaging it with the breaker blade.

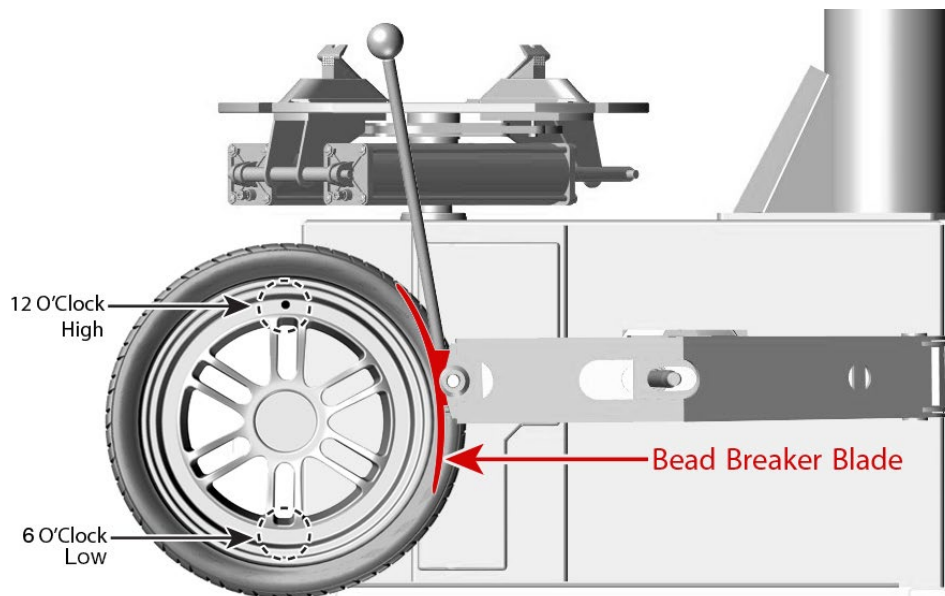

7. Move the blade so that it is on the side of the tire, very close to, ***but not touching***, the rim.

⚠ CAUTION Make sure the blade is ***not*** touching the rim. The Bead Breaker mechanism uses a great deal of force. The rim could be damaged if the blade pushes on it instead of the side of the tire.

-
8. Step on and hold down the Bead Breaker Foot Pedal.
The blade pushes in, moving the bead out of the bead seat and in towards the center of the tire.
When the bead breaks, it frequently (but not always) makes a popping sound.
 9. Release the Bead Breaker Foot Pedal when the blade goes all the way in or the bead is broken.
 10. If the Blade does not fully break the bead, adjust the tire and/or the blade a little bit toward or away from the rim and then step on and hold down the Bead Breaker Foot Pedal again.
It may take several attempts to fully break the bead.
 11. When the bead is broken at the current location, rotate the tire 180° and break the bead at that location.

Important: Every tire is different. With some tires, the entire bead on one side could be broken with the first use of the Bead Breaker Blade. Other tires could take multiple attempts until the bead is broken all of the way around the tire.

12. When the bead is completely broken all the way around on one side of the tire, move the tire out, turn it around, and then break the bead on the other side of the tire.

Again, avoid breaking the bead at the Tire Pressure Monitoring System (TPMS) as this could damage the sensor.

Important: It may take two or three tries to break the bead at any one spot. Nevertheless, keep going until the bead is broken all the way around the tire and on both sides of the tire.

 **WARNING** Do *not* proceed to demounting the tire until the bead is broken ***all the way around*** the tire and on ***both sides***.

Securing the Wheel on the Turntable

Before demounting a tire, the wheel must be secured on the Turntable.

The Tire Changer supports two methods of securing a wheel:

- **External clamping.** The Clamps are on the outside of the wheel's rim, pressing inwards.
- **Internal clamping.** The Clamps are on the inside of the wheel's rim, pressing outwards.

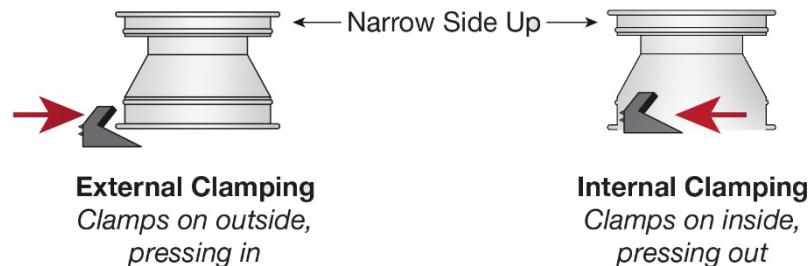

As a general rule, steel wheels clamp internally and custom and mag wheels clamp externally. Check with a supervisor if it is unclear about which method to use for a particular wheel.

To Secure a Wheel on the Turntable:

1. Make sure operators are wearing OSHA-approved (publication 3151) Personal Protective Equipment: leather gloves, steel-toed work boots, back belts, hearing protection, and ANSI-approved eye protection (safety glasses, face shield, or goggles).
2. Identify the narrow side of the tire; this side goes up.
3. Determine which clamping method to use.
 - When clamping externally, move the Clamps all the way **out**.
 - When clamping internally, move the Clamps all the way **in**.
4. Put the wheel onto the Turntable, either between the Clamps that are all the way out for external clamping or over the Clamps that are all the way in for internal clamping.
5. Secure the wheel:
 - When clamping externally, move the Clamps **in** until the wheel is being held firmly in place.
 - When clamping internally, move the Clamps **out** until the wheel is being held in place.



Tip

This tip applies to the AT26A only. Clamping externally can be difficult with some hard sidewall tires. If the Clamps will not hold externally, press down on the wheel using the Restraint Block and the Assist Arm on the wheel from above. See [Using the Assist Tower](#).

Demounting a Tire

Demounting a tire is the process of taking a tire off a wheel. This requires pulling the top bead over the **top** of the rim, then pulling the bottom bead also over the **top** of the rim. During demounting, the bead goes over the Demount Lip of the Mount/Demount Head but stays under the Mount Lip. See [Mount/Demount Head](#) for additional information.

 **DANGER**

When the Turntable is rotating, keep hands and body clear of the tire, the wheel and the Mounting/Demounting Head. Do not wear loose clothing or jewelry that could pose a risk to the operator.

 **CAUTION**

Tire lubricant must be used. Lubricant makes the tire demount more easily and helps to prevent damage to the wheel and/or the tire.

 **WARNING**

The following procedure **requires** that the tire's beads are broken on **both** sides. **Do not** try to demount a tire whose beads are not broken on both sides; the wheel or tire could be damaged, or injury to the operator or bystanders could occur.

Demounting a Tire:

1. Make sure operators are wearing OSHA-approved (publication 3151) Personal Protective Equipment: leather gloves, steel-toed work boots, back belts, hearing protection, and ANSI-approved eye protection (safety glasses, face shield, or goggles).
2. Verify that the tire's beads are completely broken on both sides of the tire.
3. Apply tire lubricant to both the top and bottom tire beads and the top rim.
This helps slide the beads over the top rim more easily.
4. Move the Mount/Demount Head into position, very close to the rim **but not touching it**, and lock it in position using the Shaft Lock Handle.



Tip

When working on multiple wheels of exactly the same size, the Mount/Demount Head can be locked to this location using the Swing Control, located next to the Swing Arm at the top of the Tire Changer. Refer to [Swing Arm](#) for more information.



Tip

This tip applies to the AT26A only. After reading through this procedure, also review [Using the Assist Tower](#).

At this point, the top Bead is under both the Mount Lip and the Demount Lip.

5. Push the top Bead 180° **opposite** the Mount/Demount Head into the drop center of the wheel.
This allows some extra room to help pull the top bead over the Demount Lip.

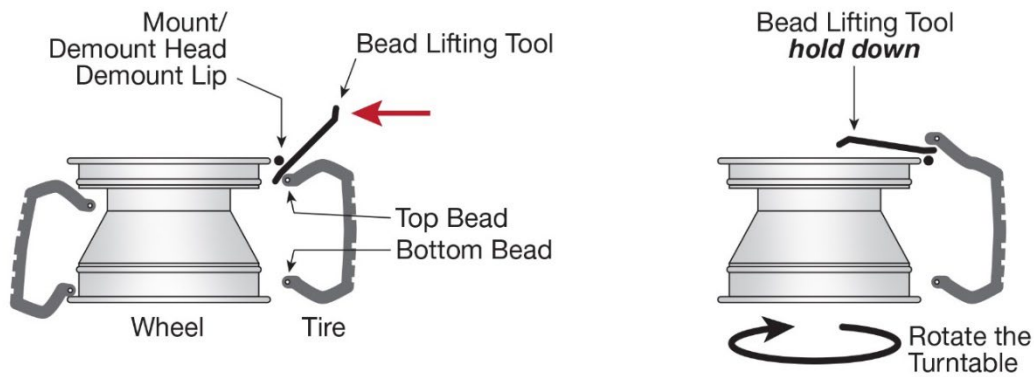

Side view. Not to scale.

6. Take the Bead Lifting Tool, position one end on the outside of the Demount Lip of the Mount/Demount Head, then slide it down between the Demount Lip and the top tire bead until it is just past (and a little under) the bead.
7. Carefully push the Bead Lifting Tool in towards the other side of the wheel in an arc. This pulls the top bead over the Demount Lip, which is correct.

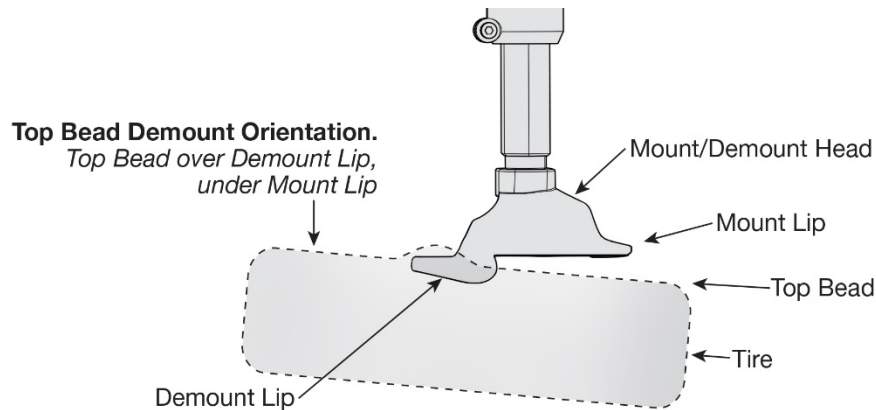

⚠ CAUTION **Hold on to the Bead Lifting Tool.** Depending on the tire, it may take a good deal of force to move the bead up and over the Demount Lip. Releasing the Bead Lifting Tool at this point could easily injure the operator or damage the wheel, tire, or the tire changer itself.

Check to make sure the Bead Lifting Tool is lifting the Tire Bead up and over the Demount Lip of the Mount/Demount Head. If the tire bead is **not** coming up and over the Demount Lip, pull the Bead Lifting Tool out and start again.

8. When the Bead Lifting Tool has moved all the way over and is lying flat, check the top bead to make sure it is above the Demount Lip.

The top bead **must** be above the top of the Demount Lip to proceed.

Continue holding the Bead Lifting Tool.

9. Press down the Turntable Foot Pedal so that the Turntable begins turning clockwise.

Note: If the Turntable will not move clockwise, release the Turntable Foot Pedal, keep hold of the Bead Lifting Tool, and then press up on the Turntable Foot Pedal for few seconds to move the Turntable counterclockwise, then press down again to move clockwise. Repeat as necessary to clear up the difficulty.

Watch the top bead to make sure it is being pushed over the rim, all the way around the tire, as the Turntable moves.

10. Keep turning the Turntable until the entire top bead pops over the top of the rim.
11. When the top tire bead pops over the rim, release the Turntable Foot Pedal and remove the Bead Lifting Tool.

The top bead is demounted.

The next step is to demount the bottom bead over the top rim.

12. Make sure there is still lubricant on the bottom bead and the top rim.
If there is not, put some more on.
13. Push the bottom bead up as much as possible all the way around the wheel, then push the side of the tire opposite the Mount/Demount Head into the drop center of the wheel.
14. Take the Bead Lifting Tool, put it on the outside of the Demount Lip, then slide it down past and under the bottom bead.

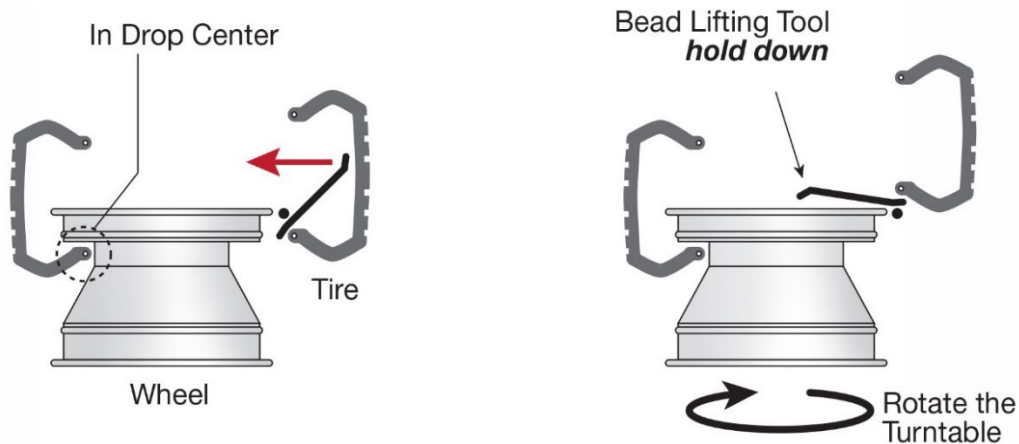

Side view. Not to scale.

Getting the Bead Lifting Tool into position may be trickier this time, as the rest of the tire is in the way while accessing the bottom bead.

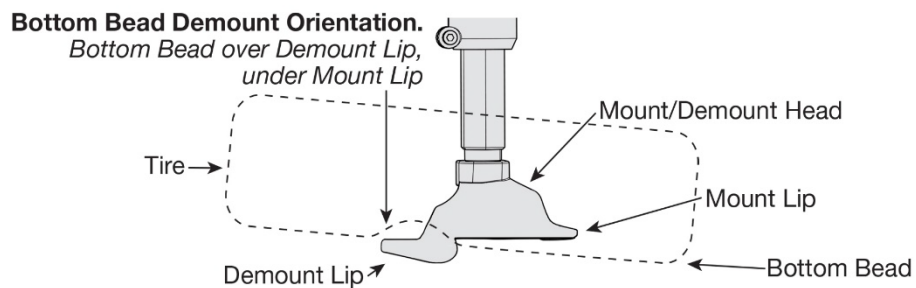

15. Push the Bead Lifting Tool towards the other side of the wheel in an arc, pulling the bottom bead over the Demount Lip of the Mount/Demount Head.

16. While continuing to hold the Bead Lifting Tool, press down on the Turntable Foot Pedal to move the Turntable clockwise. Watch the bottom bead to make sure it is being pushed over the top of the rim as the Turntable moves.

17. Keep turning the Turntable until the entire bottom bead pops over the top rim.

The tire is now dismounted and can be removed.

Wheel / Tire Mismatches

A wheel/tire mismatch is mounting a tire when the tire's bead diameter does not exactly match the diameter of the wheel/rim.

⚠ DANGER *A wheel / tire mismatch is extremely dangerous. A mismatched tire and wheel may separate or explode, resulting in injury or death.*

The differences can be subtle, so care must be taken in order to get an **exact match**.

For example, a 16 inch tire goes on a 16 inch wheel, not a 15.5 or a 16.5 inch wheel. It may be possible to slide the 16 inch tire over the rim lip of a 16.5 inch wheel, but during inflation it will **not** seat properly.

⚠ DANGER *Do not mount a tire on a wheel until the tire and rim diameters have been positively identified and correctly matched. When attempting to seat a tire bead on a mismatched wheel and tire by inflating it, the tire bead may break with explosive force, which could result in serious injury or death.*

More information is available in OSHA standard 29 CFR 1910.177 (Servicing Multi-Piece and Single Piece Rim Wheels). All Operators should study this document prior to servicing any tires.

Mounting a Tire

Mounting a tire is the process of putting a tire onto a wheel.

⚠ DANGER *Mounting a new tire can be hazardous if not done correctly. Do not allow operators to change a tire unless they have been trained to do so. Failure to understand and follow proper procedures can result in injury or death.*

During mounting, the tire bead goes over the Mount Lip of the Mount/Demount Head but stays under the Demount Lip. See **Mount/Demount Head** for additional information.

Review the following points before mounting a tire:

- Check the tire and wheel to make sure they are an **exact** match.
- If desired, replace the wheel's valve stem before mounting the tire.
- Make sure the wheel is both clean and free of balancing weights. Remove any weights and any corrosion found on the wheel, and **do not** service heavily corroded wheels.
- Check the tire for damage; **do not mount a damaged tire**.
- Check the location of the TPMS and adjust the tire if necessary. Do not damage the sensor.
- Check for yellow and red balance indicator dots on the tire and line them up appropriately with the balance indicating dot on the wheel.
- Make sure the tire is **fully** deflated.

When mounting a tire, the bottom bead is mounted first (over the top rim), then the top bead.

To Mount a Tire:

1. Make sure operators are wearing OSHA-approved (publication 3151) Personal Protective Equipment: leather gloves, steel-toed work boots, back belts, hearing protection, and ANSI-approved eye protection (safety glasses, face shield, or goggles).
2. If the wheel is not already secured on the Turntable with the narrow side facing up, move the wheel onto the Turntable and secure internally or externally.
3. Apply tire lubricant to the top and bottom beads and the top rim.
4. Put the tire over the wheel, with the side that will be next to the Mount/Demount Head low and the other side high (above the top of the wheel).
5. Swing the Mount/Demount Head into position.
6. Bring up the low side of the tire and put the **bottom** tire bead over the Mount Lip and under the Demount Lip of the Mount/Demount Head.

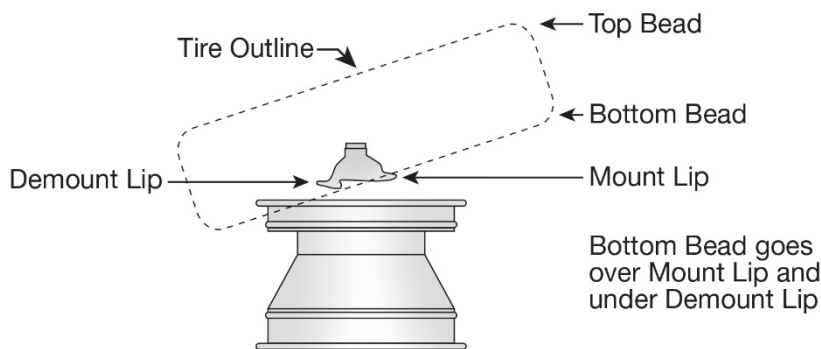

Side view. Not to scale.

7. Push the side of the tire furthest away from the Mount/Demount Head down over that side of the rim and wheel as far as it will go.
8. On the opposite side of the tire, make sure the bottom tire bead is in the wheel's drop center.
9. Press down on the Turntable Foot Pedal.
The Turntable will turn clockwise and the bottom tire bead will drop over the top of the rim.
10. Put the **top** tire bead over the Mount Lip and under the Demount Lip of the Mount/Demount Head.

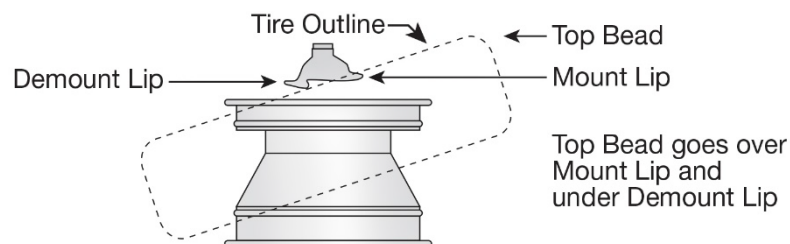

Side view. Not to scale.

11. Position the Bead Lifting Tool to the left of the Mount/Demount Head (about 20 percent of the distance around the tire), with the Bead Lifting Tool pushing down on the sidewall of the tire.

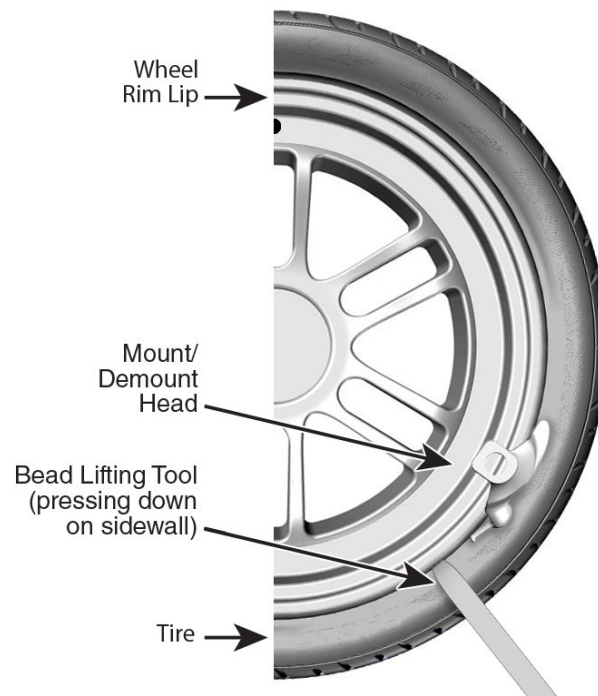

Top view. Not to scale.

12. When the tire starts rotating, move the Bead Lifting Tool around as the tire moves around, keeping the tool at the same spot on the tire.
13. Press down on the Turntable Foot Pedal to move the Turntable clockwise.
If using the Bead Lifting Tool to hold down the tire sidewall starting near the Mount/Demount Head, move it around with the tire as it rotates.
14. If there are any issues as the tire rotates, release the Turntable Foot Pedal to stop the Turntable, then press up on the Turntable Foot Pedal to turn the Turntable counterclockwise. Make any necessary adjustments and then proceed.

Eventually the top tire bead slips under the rim. How long this takes can vary, based on the tire being mounted.

The tire is now in place around the wheel rim. The next step is to inflate the tire.

On the AT26A only, also see [Using the Assist Tower](#).

Inflating a Tire

Tire inflation has three stages:

- **Bead sealing** is putting in a small amount of air pressure to push the tire up against the rim, creating a seal so air does not leak out. *Remove the Valve Core before beginning the bead sealing*, as that allows more air to go in through the valve stem.
- **Bead seating** is putting more air pressure into the tire until a “pop” sound is heard, which indicates the beads (on both sides of the tire) have slipped over the Bead Humps into their Bead Seats. *Put the Valve Core back in once the beads are seated.*
- **Inflation** is adding more air pressure to the tire to get the pressure up to the manufacturer’s recommended pressure for the tire. ***Do not stand over the tire when inflating it.***

Each of these stages is covered separately below.

 **CAUTION** The inflation process can produce a great deal of noise. Wear ear protection when inflating a tire.

 **WARNING** Do not exceed the maximum air pressure specified by the tire manufacturer. This increases the chances that the tire could explode, causing injury or death. Use the Inflation Gauge to monitor the air pressure in the tire being inflated.

 **DANGER** When inflating a tire that requires more than 60 psi, a tire inflation gauge, such as the **RIC-4716**, must be used—for safety purposes. If a tire fails at high pressure, it can explode and cause serious injury or death to anyone near it. Using a tire inflation gauge helps reduce the danger.

Important inflation notes:

- Identify the **recommended** inflation pressure of the tire (this can usually be found on a sticker on the driver-side door jamb of the vehicle or in the owner’s manual) and the **maximum** inflation pressure of the tire (usually located on the sidewall). When inflating, **the goal is to reach the recommended inflation pressure**. Do **not** exceed the maximum inflation pressure when inflating the tire.
- Make sure the tire is restrained for inflation: either *internally* clamped or in a tire inflation cage such as the **RIC-4716**.

Important: Do not inflate a tire if it is externally clamped as external clamping interferes with inflation.

Bead Sealing

To seal a tire’s beads, putting a small amount of air pressure into the tire pushes it up against the rim so that additional air does not leak out.

Sealing the Beads:

1. Make sure operators are wearing OSHA-approved (publication 3151) Personal Protective Equipment: leather gloves, steel-toed work boots, back belts, hearing protection, and ANSI-approved eye protection (safety glasses, face shield, or goggles).
2. Make sure the valve core has been removed.
3. Clip the Air Chuck to the valve stem.

The Air Chuck includes a self-gripping clip so it does not need to be held in place during inflation.

 **WARNING** ***Do not hold the Air Chuck while inflating a tire.*** This leaves the operator too close to the tire, which could result in injury if there is a problem during inflation.

4. Squeeze the Air Inflation Gun trigger for a second or two.

Air will flow into the tire and seal the bead.

Bead sealing takes very little air pressure, anywhere from 0 to 3 psi, which can be monitored on the Inflation Gauge.

The bead is sealed when air can no longer be heard coming out from between the wheel rim and the tire beads.

5. Check to make sure the upper and lower beads are both sealed against the rim.

If the beads are ***not*** sealed, try again, putting in slightly more air.

Bead Seating

To seat a tire's beads, put in additional air pressure until a "pop" is heard, which indicates the tire beads have slipped over the Bead Humps into their Bead Seats.

Remember that a tire has beads on *both sides* of the tire. The beads have to be seated on both sides. Bead seating is not complete until the beads are seated on both sides of the tire.

⚠ WARNING ***Do not exceed 40 psi to seat a Bead.***

The following procedure assumes the tire's beads have already been sealed. Do not try to seat the beads until they have been successfully sealed.

To Seat the Beads:

1. Make sure the Air Chuck is clipped to the Valve Stem of the tire.
2. Step back from the tire.
3. Squeeze the Air Inflation Gun trigger.

Air will begin flowing into the tire.

After a few seconds a "pop" sound should be heard, as the beads become seated.

Bead seating usually requires 7 psi or above.

Some beads are hard to seat, but never exceed 40 psi to seat the bead.

If air pressure in the tire gets to 40 psi but the beads are still ***not*** seated, use the Pressure Release Valve, located near the Inflation Gauge, to reduce the air pressure down to about 5 psi and then try again to seat the beads. If the air pressure is lowered too far the bead seal may be lost and the process will have to be repeated.

4. Release the Air Inflation Gun trigger at about 7 psi.
5. If the beads do not seat on a second attempt, either:
 - a. Get a different tire
 - b. Ask a supervisor for instructions
 - c. Use the pressure release valve to let all of the air out of the tire and start again (seal the beads and then attempt to seat the beads again).
6. If the amount of air pressure required to seat the beads exceeds the manufacturer's recommended pressure for the tire, use the Pressure Release Valve to remove air pressure, bringing it back down to the recommended pressure for the tire.
7. When the Beads are seated, remove the Air Chuck from the Valve Stem and **reinstall the Valve Core.**

Inflating the Tire

To inflate a tire after sealing and then seating the beads, add air pressure to the tire up to the manufacturer's recommended pressure.

Use the Inflation Gauge to monitor the tire air pressure. Do not attempt to guess the pressure.

⚠ DANGER When inflating a tire that requires more than 60 psi, a tire inflation cage, such as the **RIC-4716**, must be used—for safety purposes. If a tire fails at high pressure, it can explode and cause serious injury or death to anyone near it. Using a tire inflation cage helps reduce the danger.

The typical inflation pressure for automobile tires is from approximately 25 to 45 psi. Light truck tire inflation pressures typically cover a wider range.

Do not exceed the tire manufacturer's **maximum** air pressure for a tire. The goal is to get to the tire's **recommended** pressure.

The Tire Changer has an air pressure limiter that is set at the factory so that it does **not** exceed 60 psi. **Do not override the pressure limiter.**

Do not inflate a tire if it is externally clamped on the Turntable; external clamping interferes with inflation. Instead, switch to internal clamping or restrain the tire in an inflation cage. (AT26A only, may use the Assist Tower with Restraining Block to restrain the tire on the Turntable during inflation.) Inflating any tire to 60 psi or higher must be inflated in a tire inflation cage such as the RIC-4716 (shown to the right).



⚠ DANGER Bypassing the pressure limiter to inflate the tire could result in the tire exploding, which could injure or kill bystanders or the tire changer operator. Do not exceed 60 psi unless the tire is in a tire inflation cage.

To inflate a Tire:

1. Verify that both the upper and lower beads are sealed and seated.
2. Verify that the Valve Core has been installed.
3. Make sure the Air Chuck is clipped to the Valve Stem of the tire using the self-gripping clip.
4. Step back from the tire.

⚠ DANGER Do **not** stand over the tire when inflating it. If the tire explodes during inflation, the operator could be injured or killed.

5. Squeeze the trigger on the Air Inflation Gun. Air will begin to flow into the tire.
6. Monitor the Inflation Gauge until the manufacturer's **recommended** pressure is reached.
7. Release the trigger.
8. Remove the Air Chuck from the Valve Stem.
9. Take the wheel off the Tire Changer.

Maintenance

Make sure the Tire Changer is maintained on a regular basis.

⚠ DANGER Disconnect the Tire Changer from power and the incoming air from the Air Source **before performing any Maintenance**. Take whatever steps are necessary to make sure the unit cannot be re-energized until maintenance is over (such as Lockout/Tag-out). Because the unit uses electrical and pneumatic energy, anyone nearby could be electrocuted or even killed if the unit is powered back on during maintenance.

The AT26 and AT26A Tire Changers use pneumatic and electrical energy. If the organization has **Lockout/Tagout policies**, make sure to implement them before performing any maintenance.

Regular Maintenance

- **Daily:** Make sure the unit is clean and dry.
- **Weekly:** Check all labels to make sure they are in place and legible. Contact APEX if replacement labels are needed.
- **Weekly:** Check the water level of the Regulator/Filter. If the reservoir is one quarter (25%) or more filled with water, drain it. Refer to **Check the Water Level** for instructions.
- **Weekly:** Check the oil feed rate of the Oiler/Lubricator. It should be 1 to 2 drops per use of a pneumatic component. If it is above or below this level, adjust it as necessary. Refer to **Check the Oil Feed Rate and Adding Oil** for instructions.
- **Weekly:** Check the amount of pneumatic oil in the Oiler/Lubricator reservoir. If it is under one half (50%) full, add oil. Refer to **Check the Oil Feed Rate and Adding Oil** for instructions.
- **Monthly:** Check the accuracy of the Inflation Gauge using a pressurized tire and a high-quality pressure gauge. Fix immediately if not working correctly.
- **Monthly:** Make sure all Anchor Bolts are tightened and secure, if used.
- **Monthly:** Make sure all components are in good operating condition. If a component is **not** working correctly take the Tire Changer out of service and refer to **Troubleshooting** for more information.
- **Bi-Monthly:** Replace the plastic inserts on the mount/demount head after every two months of use, or as required. See illustration to the right.

Part No.	Description
5328119	Insert
5327636	Roller Insert

- **Yearly:** Take the Tire Changer out of service, disconnect the Power Cord from the power source, and then thoroughly check and clean all components.

⚠ WARNING: Do not operate the unit if any issues are found. Take it out of service and contact the dealer, visit Bendpak.com/support, or call **(877) 432-6627**.

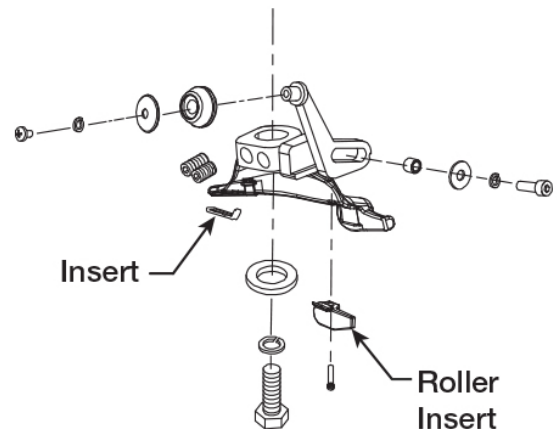

- **Yearly:** Check the belt tension and tighten if required. Remove power and air supply from the Changer. Refer to the drawing to the right. Remove the side panel and loosen nuts A and B. Tighten by adjusting the bolts at the front of the motor bracket. Belt is to deflect inwards under 8 kg of force.

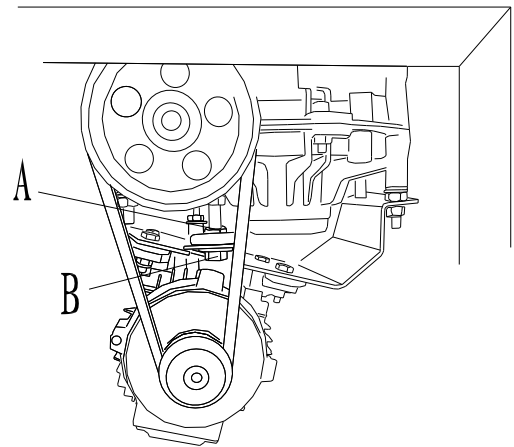

Check the Water Level

Water is removed from the incoming Air Supply by the Regulator/Filter and dropped into the reservoir.

This water must be drained periodically to maintain the filter's efficiency and prevent the water from escaping into the Tire Changer.

To drain water from the Regulator/Filter reservoir:

1. Check the Water Sight Gauge to see how much water is currently in the reservoir.
If the reservoir is one quarter (25%) or more filled with water, it should be drained.
2. Disconnect the air source at the Air In connector.

⚠ WARNING Make sure to disconnect the air source and make sure it cannot be reconnected until the water is fully drained from the Regulator/Filter. If the air source is reconnected during the procedure, it could damage the Regulator/Filter, the Tire Changer, and possibly injure bystanders.

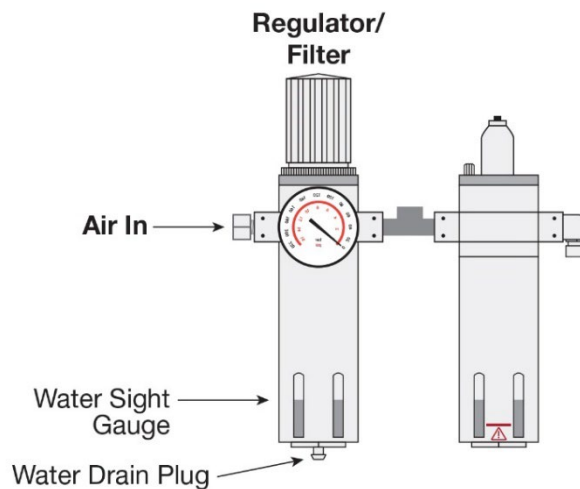

3. Press upward on the Water Drain Plug at the bottom of the reservoir. The water should drain out.
4. Release the Water Drain Plug.
5. Re-connect the air source.

Checking the Oil Feed Rate and Adding Oil

The built-in lubricator adds pneumatic oil to the incoming air. This ensures that all pneumatic components of the Tire Changer receive the necessary lubrication, which maintains operating performance, reduces wear, and extends service life.

Important: Make sure the oil feed rate is correct, 1 or 2 drops of oil per use of a pneumatic component (such as the Clamps **In** or **Out**), and that there is enough pneumatic oil in the Oil Reservoir of the Oiler/Lubricator. .

To check the oil feed rate on the Oiler/Lubricator:

1. With the air source connected, press and release the **Clamps** foot pedal.
A wheel is not needed on the Turntable; only a pneumatic tool is required.
2. Watch the Sight Glass to see how much pneumatic oil comes out each time the Clamps **In** or **Out** Foot Pedal is pressed. The oiler should provide one or two drops of oil per clamp activation.
3. If **fewer** than 1 or 2 drops comes out, turn the Adjustment Screw counterclockwise (using a small flat-head screwdriver), then press the Clamps **In** or **Out** Foot Pedal again to check the output.
4. If **more** than 1 or 2 drops comes out, turn the Adjustment Screw clockwise, then press the Clamps **In** or **Out** foot pedal again to check the output.
5. When the oiler is providing the 1 or 2 drops, per activation the adjustment is complete.

To add pneumatic oil to the Oiler/Lubricator:

1. Check the Oil Sight Gauge to see how much pneumatic oil is currently in the reservoir.
If the reservoir is less than one half (50%) filled with pneumatic oil, add more.
2. Disconnect the Air Source at the Air In connector. Press the Pressure Release Valve on the Air Inflation Gun to verify the Tire Changer air supply is off and release any pressure in the system.
3. Turn the Oil Fill Cap on the top of the Oil Reservoir counterclockwise and pull it off.
4. Add SAE 10W Air Tool Oil or generic pneumatic oil to the reservoir.
5. Put the Oil Fill Cap back in place, turning it clockwise until tight.
6. Re-connect the air source.

Troubleshooting

⚠ WARNING: Disconnect the power cord from the power outlet and the incoming air from the air source **before performing any maintenance**. Take whatever steps are necessary to make sure the unit **cannot** be re-energized while maintenance is being performed on it. The unit uses pneumatic and electrical energy. If the organization has Lockout/Tagout policies, make sure to implement them before troubleshooting the Tire Changer.

Issue	Action to Take
The Turntable does not move when depressing the Turntable Foot Pedal.	Make sure the unit is getting power. Verify the electrical plug is not damaged. Verify the motor runs when depressing the foot pedal. Tighten or replace the belt. Replace the foot switch.
The Tire Changer is not getting power.	Have a licensed electrician check the electrical path from the supplied cord to the power source. If any issues are found, have them repaired.
Foot pedals fail to reset after depressing.	Return spring is worn, damaged or broken. Replace spring.
No air comes out when squeezing the trigger on the Air Inflation Gun.	Make sure the Tire Changer is correctly connected to a functioning air source.
It is difficult to secure tires when clamping externally.	Press the tire down by hand. (AT26A Only) use the Assist Tower with the Restraint Block to press down on the wheel so the external Clamps correctly grab the rim of the wheel.
Bead Breaker does not move or moves with insufficient force to decompress the tire bead.	Replace Bead Breaker air cylinder sealing element. Replace the Bead Breaker Air Cylinder.
Air leaks from the center of the Air Cylinder.	Replace the seals or the Air Cylinder.
The Turntable does not turn, or stops when attempting to guide the tire bead into place.	Belt tension too loose. Use sufficient lube. Motor capacitor failure. Replace capacitor. Replace Motor. (AT26A Only) Use Assist Arm to aid in bead seating.

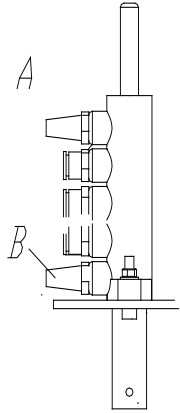
Issue	Action to Take
Loud grinding noise and / or Turntable won't turn.	Gearbox failure – replace.
The Turntable Clamps cannot hold a wheel.	Damaged or worn Clamp Jaws. – replace. Damaged Air Cylinder – replace. Replace the Air Cylinder sealing element at the Turntable.
The Swing Arm Hexagonal Shaft does not move up and down smoothly.	The shaft locking plate is out of adjustment. Loosen the bolts of the locking plate and readjust. The shaft locking plate is worn. Replace the locking plate.
The Inflation Gauge is not working correctly.	Check the accuracy of the Gauge with a professional gauge. Fix immediately if the Gauge is not working correctly.
Air cylinder speed is too slow.	<ol style="list-style-type: none"> 1. Cut off air and power to the Tire Changer. 2. Remove the side panel. 3. Adjust the silencers A and B on the valve body pictured below. 4. Replace the silencers if damaged. 

If problems with the Tire Changer continue, visit <https://www.bendpak.com/support/> or call **BendPak at (877) 432-6627.**

Labels

J
(Place wherever needed-
at any pinch points)

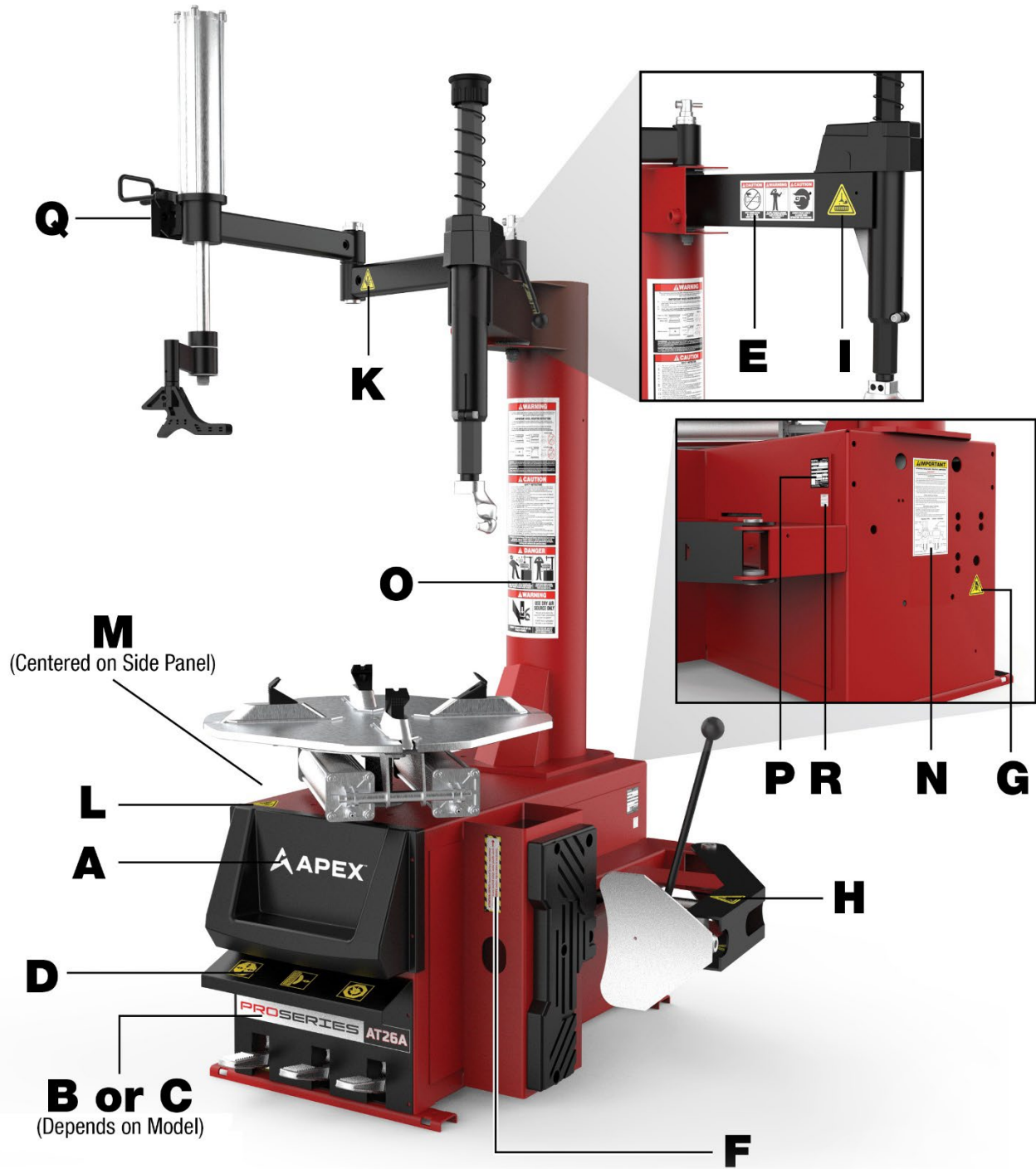

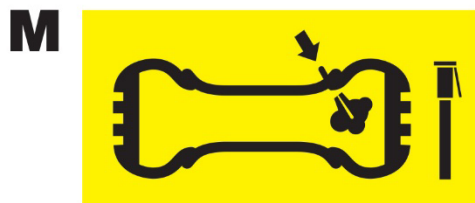
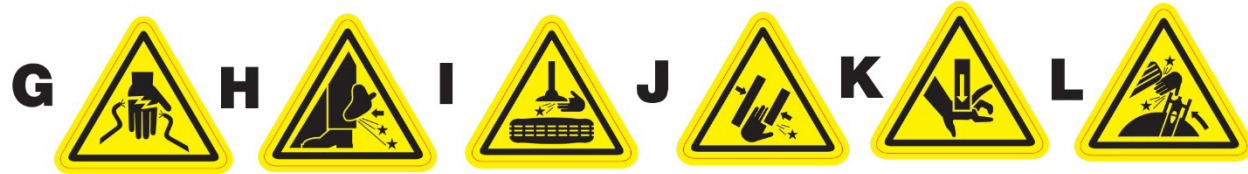

N

IMPORTANT

FILTER / REGULATOR LUBRICATOR INSTRUCTIONS

WARNING!
Failure to regularly drain water and maintain proper oil level and oil feed rate will damage internal pneumatic components and void the product warranty.

The inline lubricator helps ensure that all pneumatic components inside this machine receive the required lubrication to maintain operating performance, reduce wear, and prolong service life. It is designed to automatically provide the correct amount of oil feed rate required within the pneumatic system, delivering a constant ratio of oil to CFM.

The filter/regulator is designed to remove airborne solid and liquid contaminants, which may plug small orifices and hinder performance or cause excessive wear and premature equipment failure. The regulator provides controlled and consistent air pressure as required. **NOTE:** This model requires a 15-25 CFM air source with a safe operating air pressure of 140-165 PSI for optimum machine performance.

Water Separator / Lubricator Maintenance

- Check oil and water levels regularly and perform these maintenance items weekly.
- Observe the water sight gauge on the water separator/filter unit. If water is observed, drain by pressing covers on the drain plug at the bottom of the reservoir.
- Observe the sight glass and adjust the oil feed rate by turning the small adjustment screw on the top of the glass bowl so that 2-3 drops of oil drip through the sight glass for each operation of the hand lever gauge.

Adding Oil to Oiler / Lubricator

If the oil level is low, add oil as follows:

1. **IMPORTANT!** First, disconnect the air source from the machine.
2. Remove the oil reservoir by unscrewing the reservoir from the head of the oiler/lubricator.
3. Add oil as necessary.
4. Replace the reservoir, making sure the O-ring U-clip is seated properly and the reservoir is firmly tightened hand-tight.

Regulator / Filter Oiler / Lubricator

Rego Products USA PN 5905417

PN 5905417

O

WARNING

The following instructions help identify when to properly maintain wheels on the tire changer. Failure to follow these instructions may result in tire damage, injury, or death.

IMPORTANT WHEEL MOUNTING INSTRUCTIONS

1. It is important to understand that this machine has a built-in air clutch. It is never possible to mount or dismount the head of the wheel on the head of the tire while the tire is on the tire.
2. Always use the correct order of the wheel. Check the Tire Center Service Size and Wheel Size Range.
3. **THE TIRE MUST ALWAYS BE POSITIONED ON THE WHEEL WITH THE WHEEL PROTRUDING ON THE OUTSIDE WITH THE NUMBER AND THE STREET NAME OF THE TIRE CENTER MARKED OUTSIDE.**

CAUTION

SAFETY INSTRUCTIONS

1. Do not use FRAX-110, FRAX-110-2, or FRAX-110-3. These are not approved for use on this machine. Failure to use approved tires may cause damage to machine or cause personal injury or death.
2. Do not use tires with a tread depth less than 1/8 inch (3.2 mm) or a tread depth less than 1/4 inch (6.4 mm).
3. Do not use tires with a tread depth less than 1/8 inch (3.2 mm) or a tread depth less than 1/4 inch (6.4 mm).
4. Do not use tires with a tread depth less than 1/8 inch (3.2 mm) or a tread depth less than 1/4 inch (6.4 mm).
5. Do not use tires with a tread depth less than 1/8 inch (3.2 mm) or a tread depth less than 1/4 inch (6.4 mm).
6. Do not use tires with a tread depth less than 1/8 inch (3.2 mm) or a tread depth less than 1/4 inch (6.4 mm).
7. Do not use tires with a tread depth less than 1/8 inch (3.2 mm) or a tread depth less than 1/4 inch (6.4 mm).
8. Do not use tires with a tread depth less than 1/8 inch (3.2 mm) or a tread depth less than 1/4 inch (6.4 mm).
9. Do not use tires with a tread depth less than 1/8 inch (3.2 mm) or a tread depth less than 1/4 inch (6.4 mm).
10. Do not use tires with a tread depth less than 1/8 inch (3.2 mm) or a tread depth less than 1/4 inch (6.4 mm).
11. Do not use tires with a tread depth less than 1/8 inch (3.2 mm) or a tread depth less than 1/4 inch (6.4 mm).
12. Do not use tires with a tread depth less than 1/8 inch (3.2 mm) or a tread depth less than 1/4 inch (6.4 mm).
13. Do not use tires with a tread depth less than 1/8 inch (3.2 mm) or a tread depth less than 1/4 inch (6.4 mm).
14. Do not use tires with a tread depth less than 1/8 inch (3.2 mm) or a tread depth less than 1/4 inch (6.4 mm).
15. Do not use tires with a tread depth less than 1/8 inch (3.2 mm) or a tread depth less than 1/4 inch (6.4 mm).
16. Do not use tires with a tread depth less than 1/8 inch (3.2 mm) or a tread depth less than 1/4 inch (6.4 mm).
17. Do not use tires with a tread depth less than 1/8 inch (3.2 mm) or a tread depth less than 1/4 inch (6.4 mm).
18. Do not use tires with a tread depth less than 1/8 inch (3.2 mm) or a tread depth less than 1/4 inch (6.4 mm).
19. Do not use tires with a tread depth less than 1/8 inch (3.2 mm) or a tread depth less than 1/4 inch (6.4 mm).
20. Do not use tires with a tread depth less than 1/8 inch (3.2 mm) or a tread depth less than 1/4 inch (6.4 mm).

DANGER

USE DRY AIR SOURCE ONLY

Warranty will be void on this equipment if water contamination is found to be apparent. ALWAYS drain air compressor tank daily or use in-line dryer.

KEEP HANDS CLEAR OF ALL FINCH POINTS.

SERVICE PARTS AND LUBRICANTS COVER UNDER WARRANTY IF RUST OR CORROSION IS PRESENT.

P

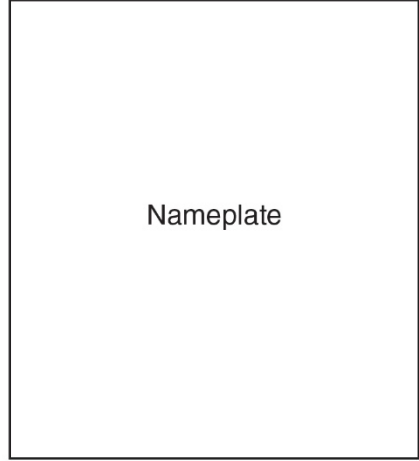

PN 5906152

Q

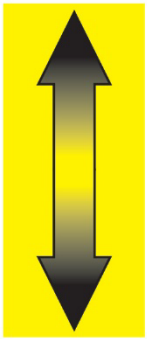

R

CALIFORNIA PROPOSITION 65

WARNING! This product can expose you to chemicals, including styrene and vinyl chloride, which are on the list of over 900 chemicals identified by the State of California to cause cancer, birth defects, or reproductive harm. ALWAYS use this product in accordance with the manufacturer's instructions.

For more information, go to www.p65warnings.ca.gov.

PN 5905775

PN 5905775

S

DANGER

GROUND ALL ELECTRICAL EQUIPMENT

Establish and maintain proper earth ground. Voltage or ground hazard sufficient to cause shock, burn, or death.

PN 5905272

CAUTION

THIS MACHINE HAS A DUAL VOLTAGE MOTOR.

BEFORE CONNECTING PLUG.

Confirm that the voltage selector switch on the back of the cabinet is positioned correctly, as serious damage to the motor/electronics will result if it is not.

PN 5905272

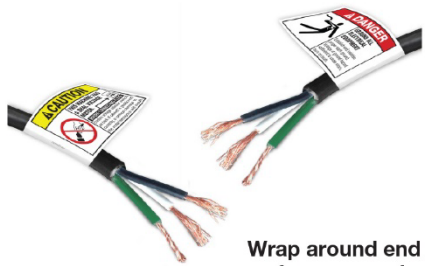

Wrap around end of power cord

Parts

Cabinet

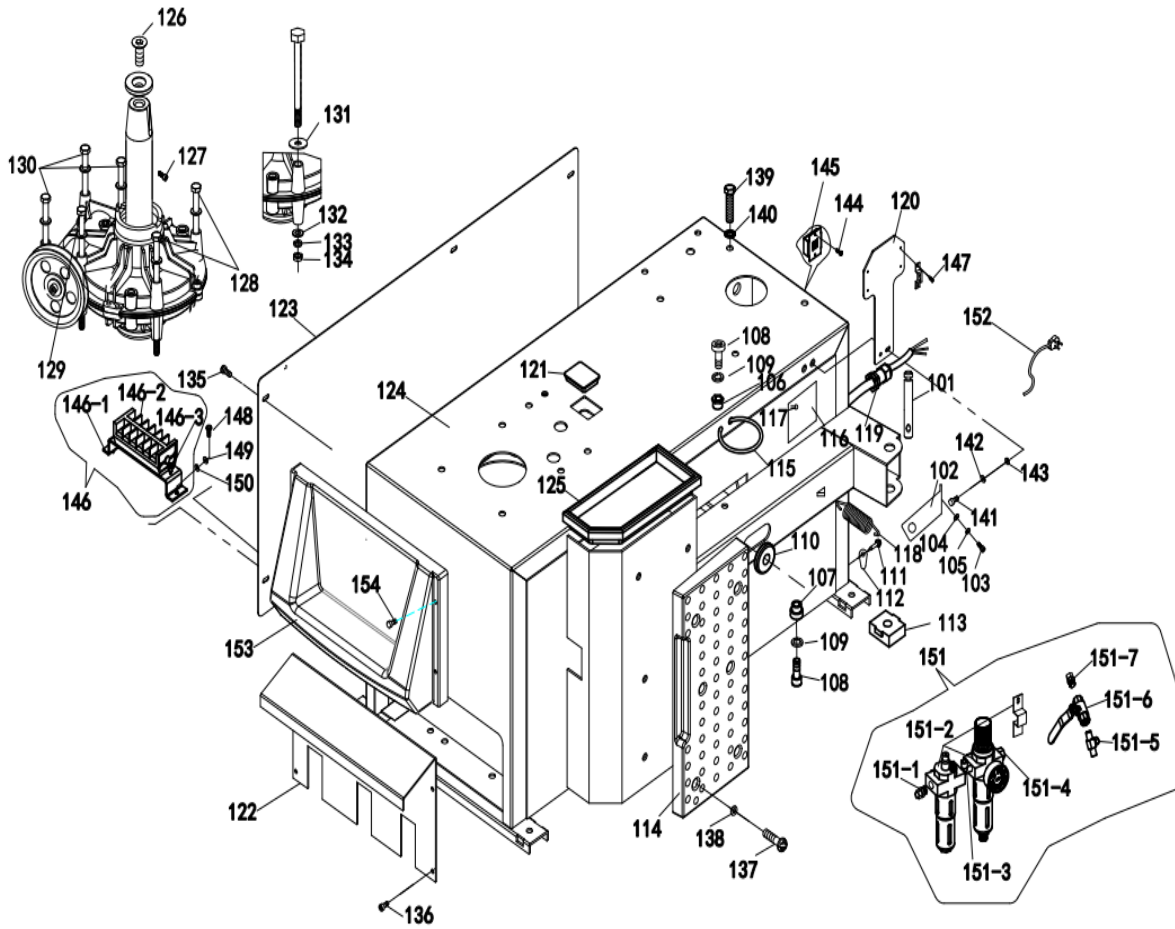

Cabinet Parts List

Part Number	Item #	Description
	101	BB Arm Shaft
	102	BB Arm Shaft Baffle
	103	SHCS M6x16
5400913	104	Washer ϕ 6
	105	Spring Washer ϕ 6
	106	Eccentric Bushing;
	107	Metal Bushing
	108	SHCS M12x35
	109	Spring Washer ϕ 12
	110	BB Arm Shock
5327530	111	STS M5.5 X 25
	112	Earth Wire Logo
5327307	113	Plastic Foot
	114	Wheel Support Pad
	115	Soap Bucket Support
	116	Label
	117	Cup Head Rivet
	118	BB Return Spring
	119	Power Cord Grip M20
	120	Air/Oil Regulator Junction Plate
5327308	121	Block
	122	Cabinet Front Plate
	123	Side Cover
	124	Chassis Weldment
	125	Tool Tray
5327604	126	Flat Socket Cap Screw; M16 x 40mm
	127	SHCS M6x10
	128	HHB M10x160
5327520	129	HHB M10x200
5327513	130	HHB M10x170
	131	Pad ϕ 10
	132	Washer ϕ 10
	133	Spring Washer ϕ 10
	134	Nut M10
	135	Large Flat Head Screw with Cross Groove
	136	Cross Recessed Round Head Screw M6X12
	137	Cross Recessed Round Head Screw M6X20
	138	Pad ϕ 6
	139	HHB
	140	Washer
	141	SHCS M6x16
5400913	142	Washer ϕ 6
	143	Spring Washer ϕ 6
	144	SHCS M4x50
5327444	145	Voltage Selector Switch
	146	Terminal Block ASSY
	146-1	Connecting Terminal Frame
5327443	146-2	Terminal Block
	146-3	Cross Recessed Tapping Screws ST4.2X13
	147	SHCS M4x12
	148	SHCS M6x16
5400913	149	Washer ϕ 6

	150	Spring Washer $\phi 6$
5328220	151	Pneumatic Triple Pieces
	151-1	Joint With Internal And External Threads
	151-2	Oil And Water Separator FRL
	151-3	Tee Fitting
5327732	151-4	Fitting; Straight $\phi 12-G1/4"$
5327824	151-5	Tee Fitting $G1/4"-\phi 8-G1/4"$
5327671	151-6	1/4" Ball Valve
	151-7	Fitting; Straight $\phi 12-G1/4"$
5401121	152	Power Line
	153	Plastic Front cover
	154	Cross recessed Round Head Screw M6x10

Tower & Air Inflation Gun

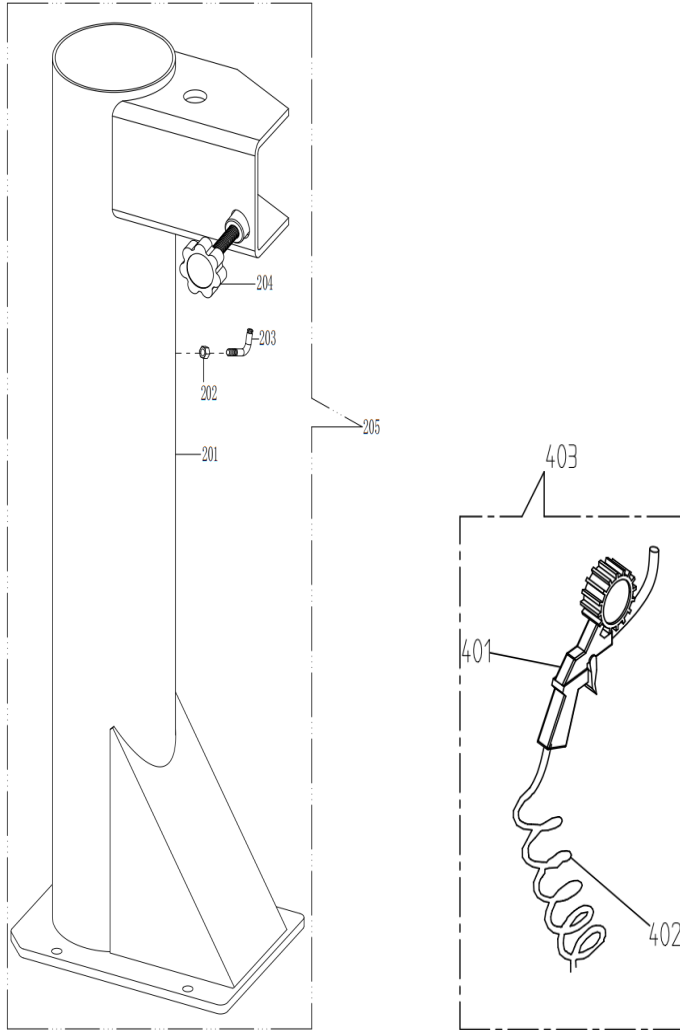

Tower Parts List

Part Number	Item #	Description
	201	Tower Unit Weldment
	202	Nut M12
5327449	203	Air Inflation Gun Hook
5401222	204	Positioning Handle
	205	Column

Air Inflation Gun Parts List

Part Number	Item #	Description
	401	Tire Inflation Gun
	402	Coiled Air Hose
5327449	403	Tire Inflation Gun Assembly

Swing Arm

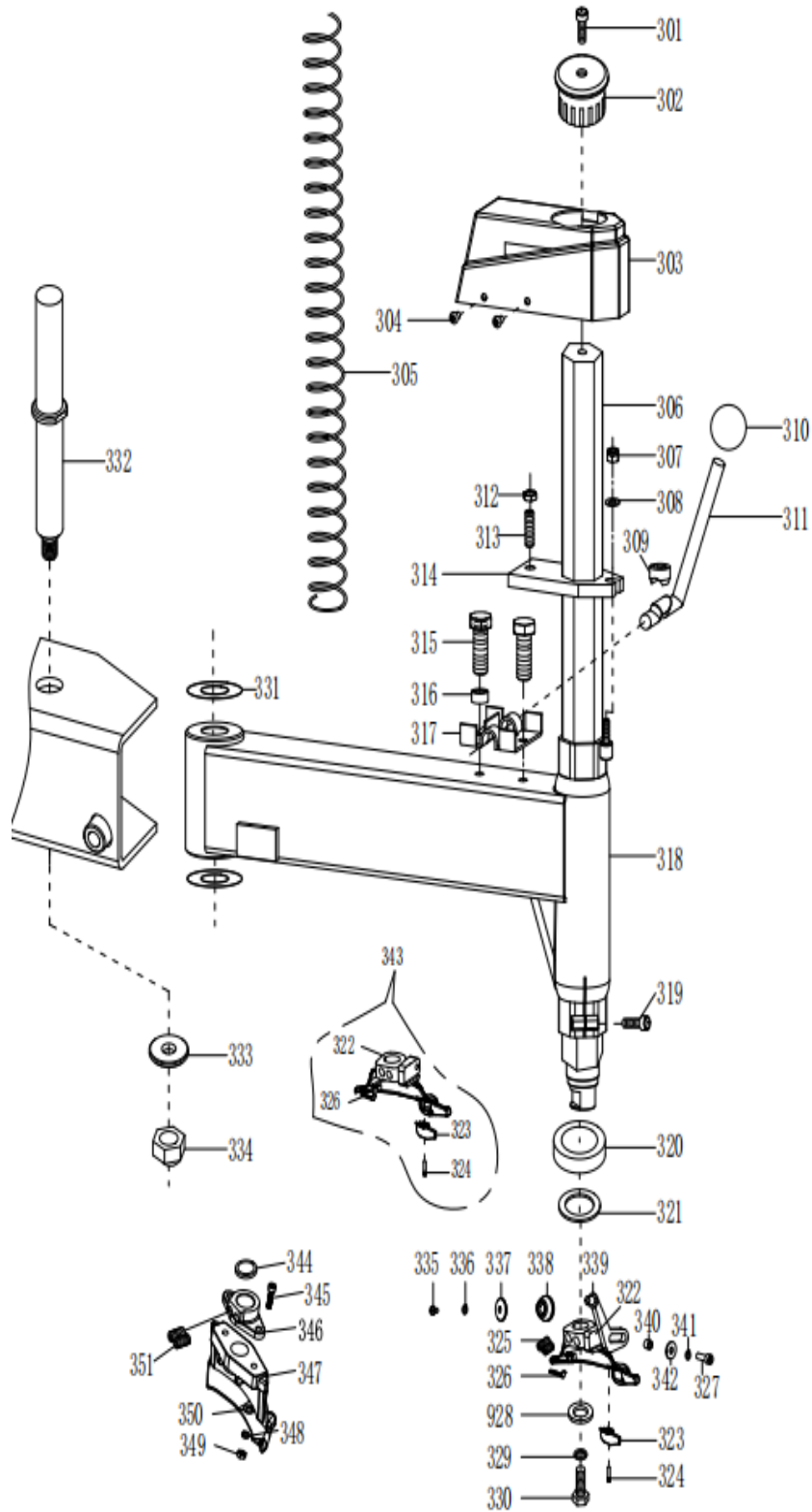

Swing Arm Parts List

Part Number	Item #	Description
5400942	301	SHCS M10x25
	302	Hex Shaft Cap
	303	Hex Shaft Lock Cover
	304	Hexagon Socket Head Screw M6x12
	305	Hex Shaft Spring
	306	Vertical Shaft
5400457	307	Lock Nut M10
	308	Washer ϕ 10
	309	Locking Block
	310	Tower Lock Knob
	311	Locking Handle
	312	Nut M12
	313	Hexagon Socket Set Screws M12x45
	314	Locking Plate
	315	HHB M8x20
	316	Reinforcing Sleeve
	317	Cover
	318	Swing Arm Unit Weldment
	319	SHCS M8x30
	320	Mount / Demount Head Bushing
	321	Washer
322	Mounting Head	
5327636	323	Roller Insert
	324	Ingot Screws
5327468	325	Hexagon Socket Set Screw with flat point M12X16
5328119	326	Mount/Demount Head Insert
	327	SHCS M8x25
5327436	328	Mount/Demount Head Retaining Washer
	329	Spring Washer ϕ 10
	330	HHB M10x25
	331	Swing Arm Adjustment Pad
	332	Swing Arm Pivot Pin
	333	Lock Pad
	334	Lock Nut M16
	335	Cross Recessed Round Head Screw M6X10
	336	Spring Washer ϕ 6
	337	Pad ϕ 6
	338	Tire Pressure Wheel
	339	Tire Pressure Arm
	340	Tire Pressure Arm Shaft
	341	Spring Washer ϕ 8
342	Pad ϕ 8	
343	Mounting Head Assy.	
344	Adjustment pad	
345	SHCS M8x40	
5328289	346	Plastic Head Flange
5150523	347	Plastic Head of a Bird
	348	Washer M8
5327884	349	Nut M8
	350	Washer M8
5327468	351	M12x16 Set Screw

Turntable Plate

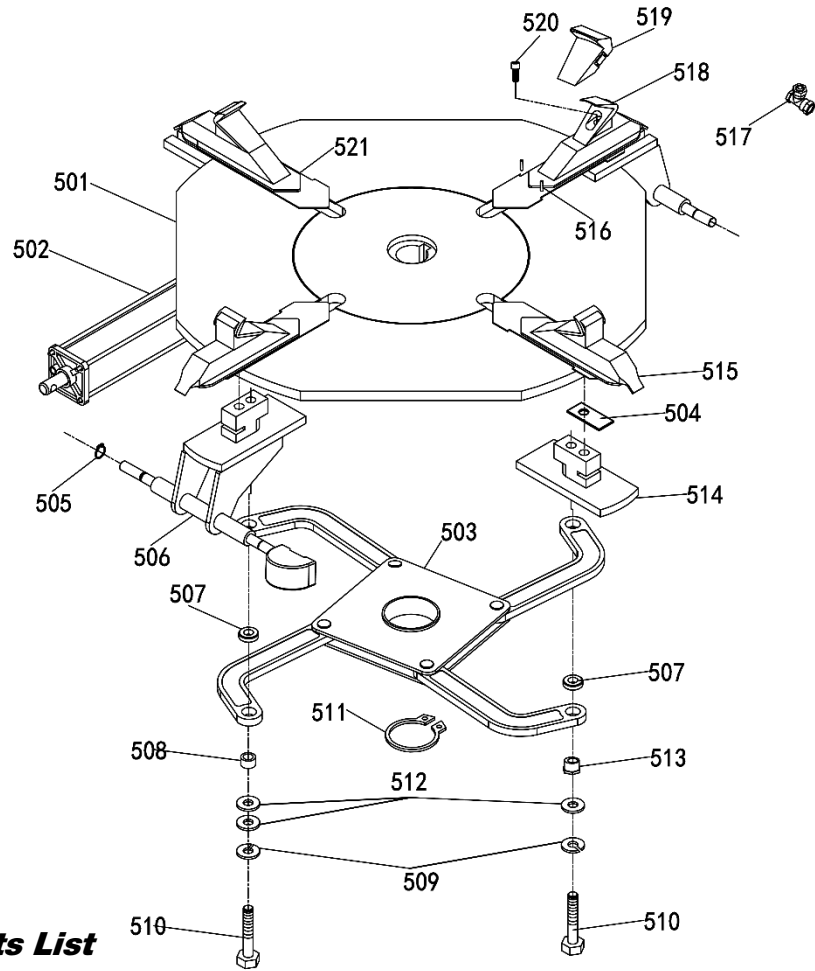

Turntable Plate Parts List

Part Number	Item #	Description
	501	Turntable Plate Welding
5327300	502	Jaw Clamp Cylinder
5327450	503	Square Turntable Assy.
	504	Slide Shim Adjustment
5400905	505	Snap Ring $\phi 12$
	506	Slide Guide
5327735	507	Square Turntable Slide Rod Pad
5327500	508	Square Turntable Shaft Sleeve
	509	Spring Washer $\phi 12$
	510	HHB M12x50
	511	Snap Ring $\phi 65$
	512	Washer $\phi 12$
	513	Eccentric Bushing
	514	Slide Guard Board
	515	Jaw Clamp Slide
	516	Elastic Cylindrical Pin $\Phi 4 \times 16$
	517	
	518	Jaw Clamp
	519	Plastic Jaw Clamp Cover
5400942	520	SHCS M10x20
	521	Boat Gasket

Square Turntable Assy.

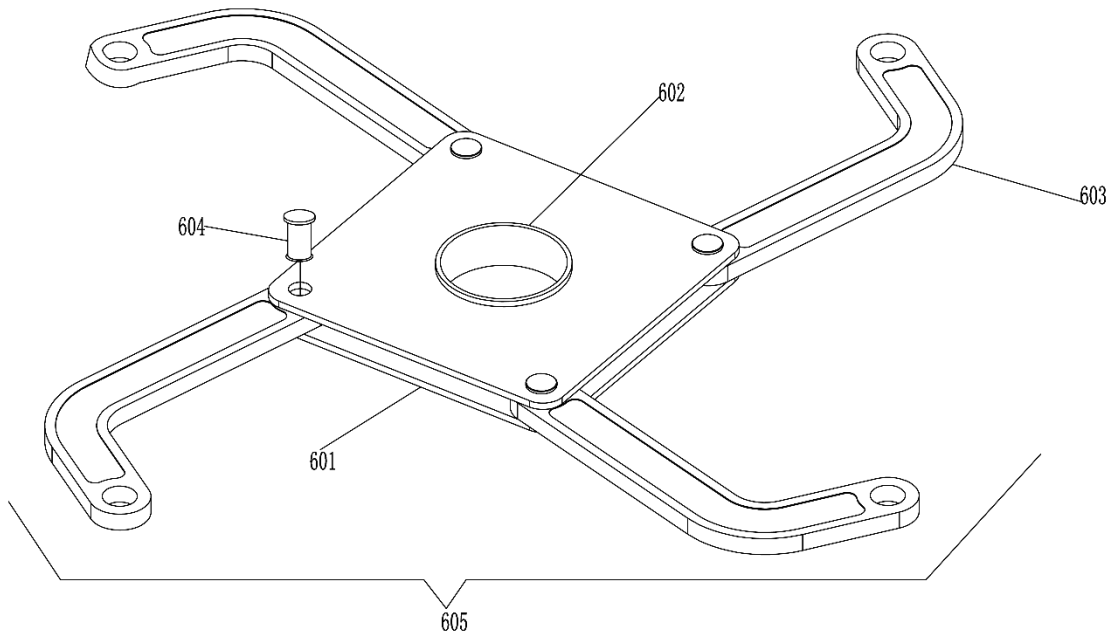

Square Turntable Assy. Parts List

Part Number	Item #	Description
	601	Square Turntable Main Board
	602	Square Turntable Spacer
	603	Square Turntable Link
5327521	604	Square Turntable Press Pin
5327450	605	Square Turntable Assy.

Jaw Clamp Cylinder

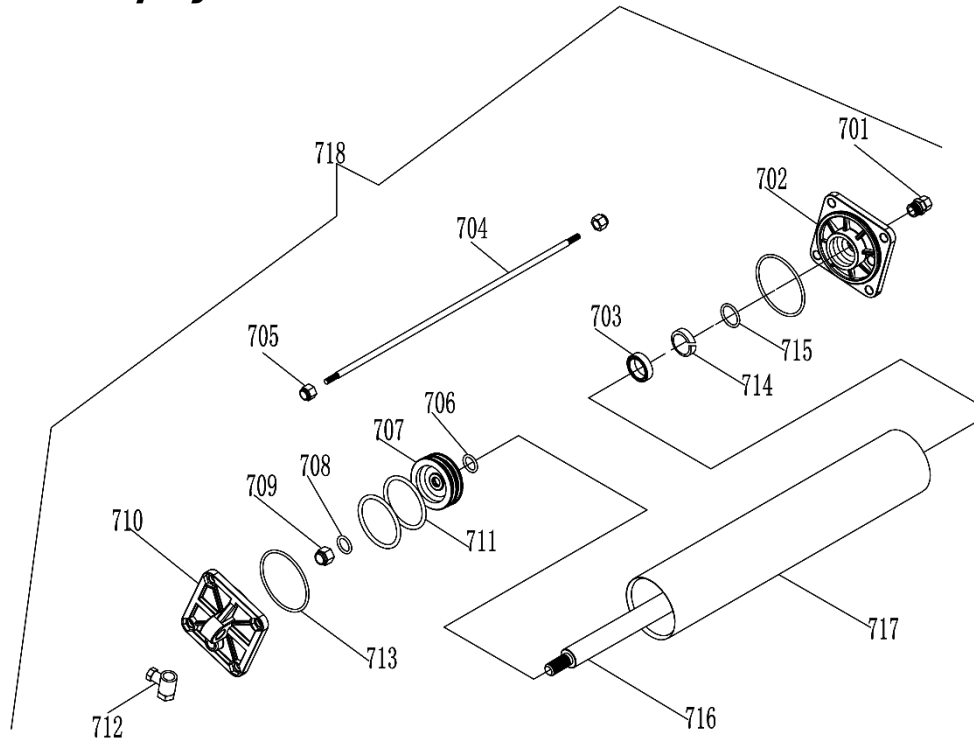

Jaw Clamp Cylinder Assy. Parts List

Part Number	Item #	Description
5327745	701	Fitting; G1/8 ϕ 8
	702	Small Front Cylinder Cover
5327494	703	Y-Ring ϕ 32x20x6
	704	HHB
	705	Nut M8
5327486	706	O-Ring ϕ 16x2.4
	707	Small Cylinder Piston
	708	Washer ϕ 12
	709	Nut M12
	710	Small Rear Cylinder Cover
5327489	711	O-Ring ϕ 75x5.7
	712	Union G1/8" elbow
5327488	713	O-Ring ϕ 75x2.65
	714	Jaw Clamp Cylinder Wear Strip
5327487	715	O-Ring ϕ 25x3.1
	716	Jaw Clamp Cylinder Rod
	717	Jaw Clamp Cylinder Body
5327300	718	Jaw Clamp Cylinder

Bead Breaker Cylinder

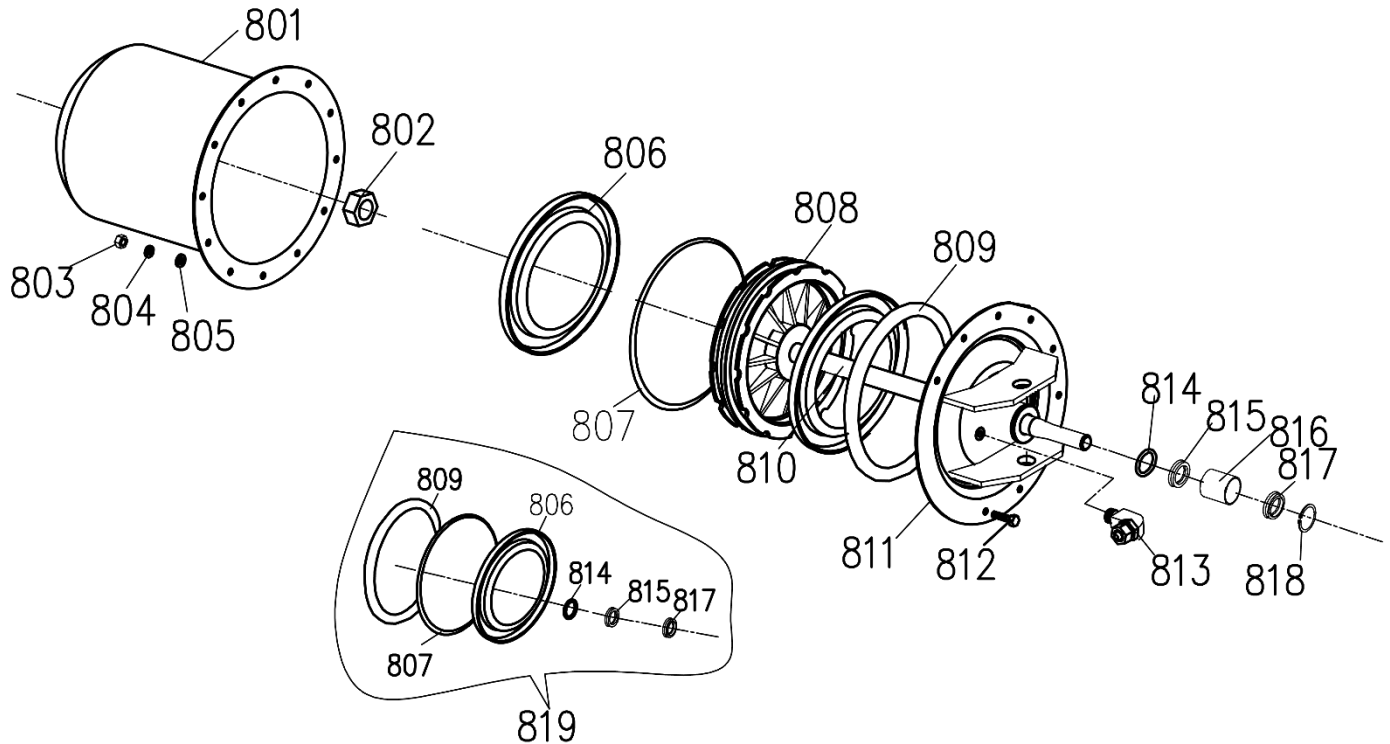

Bead Breaker Cylinder Parts List

Part Number	#	Description
	801	Cylinder Liner
	802	Nut M18X1.5 - Thin Threaded
	803	Nut M6
	804	Spring Washer $\phi 6$
5400913	805	Washer $\phi 6$
5327682	806	Y-Ring $\phi 200 \times 12 \times 6$
	807	O-Ring $\phi 195 \times 5.9$
5327413	808	BB Cylinder Piston
5327537	809	O-Ring $\phi 193 \times 5.7$
	810	BB Cylinder Rod
5401520	811	Big cylinder Flange Unit Weldment
	812	SHCS M8x16
	813	Fitting 90° $\phi 10$ -G1/4"
5327487	814	O-Ring $\phi 25 \times 3.1$
5327493	815	Y-Ring $\phi 25$
	816	Oil Bearing $\phi 23 \times \phi 20 \times 20$
	817	Seal Ring $\phi 30 \times 20 \times 7$
	818	Type I Hole with Elastic Ring $\phi 32$
	819	Bead Breaker Cylinder Assy.

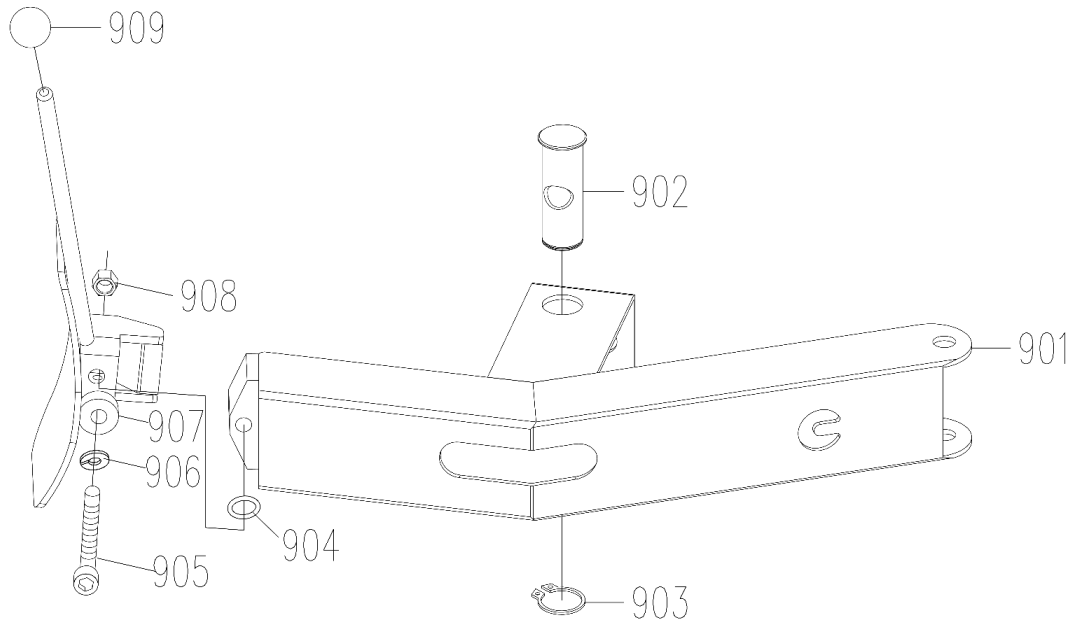

Bead Breaker Bracket Parts List

Part Number	Item #	Description
	901	Bead Breaker Arm
	902	Bead Breaker Arm Pivot Pin
	903	Seeger Ring ϕ 35
	904	Curved Spring Washers ϕ 16
5327609	905	SHCS M14x95
	906	Spring Washer ϕ 14
	907	Bead Breaker Blade
	908	Lock Nut M14
	909	Bead Breaker Blade Handle

Quick Release Valve Section (A)

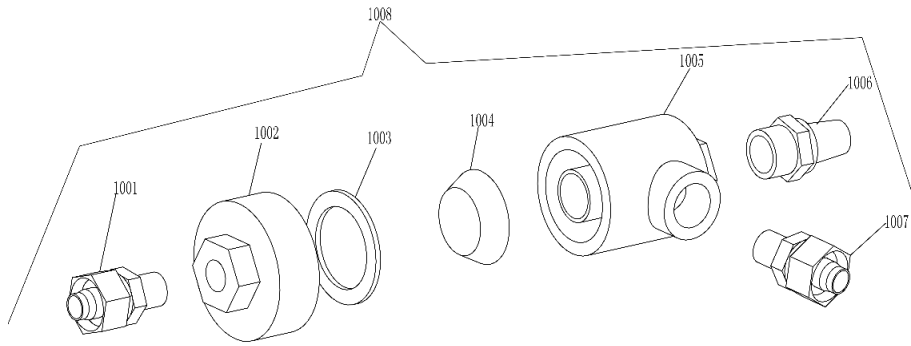

Quick Release Valve Section (A) Parts List

Part Number	Item #	Description
	1001	Fitting ϕ 10-G1/8"
	1002	Plastic Quick Release Cover
	1003	Plastic Quick Release Valve Leather Pad
	1004	Plastic Quick Release Valve Cover Bowl
	1005	Plastic Quick Release Valve Body
5327561	1006	Copper Silencer
	1007	Fitting ϕ 10-G1/4"
	1008	Quick Release Valve Section

Quick Release Valve Section (B)

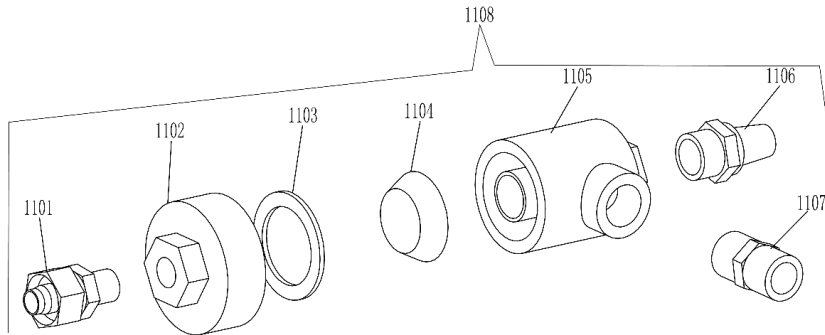

Quick Release Valve Section (B) Parts List

Part Number	Item #	Description
	1101	Fitting ϕ 10-G1/8"
	1102	Plastic Quick Release Cover
	1103	Plastic Quick Release Valve Leather Pad
	1104	Plastic Quick Release Valve Cover Bowl
	1105	Plastic Quick Release Valve Body
5327561	1106	Copper Silencer
	1107	Screwed Nipple; G1/4" -G1/4"
	1108	Quick Release Valve Section

Gearbox

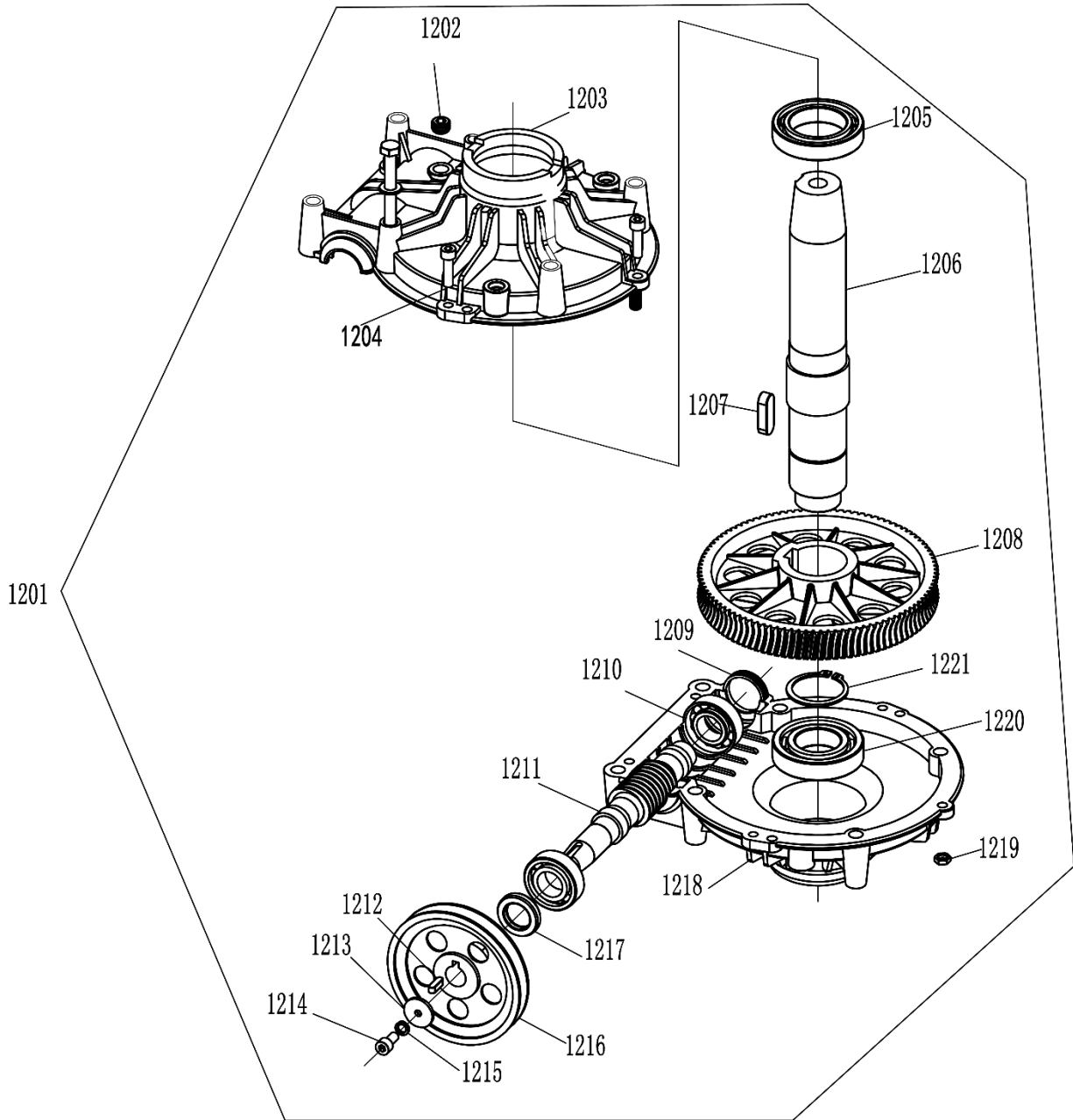

Gearbox Parts List

Part Number	Item #	Description
	1201	Gearbox
	1202	Oil Plug
	1203	Gearbox Front Flange
	1204	SHCS M8x30
	1205	Bearing
	1206	Cone Shaft
	1207	Turbine Key 14x8x40
	1208	Turbine
	1209	Oil Block
	1210	Cone Roller Bearing
	1211	Gear Stud
	1212	Turbine Key 6X6X20
5545202	1213	Gear Stud Pad
	1214	SHCS M8x16
	1215	Spring Washer ϕ 8
5327976	1216	Big Size Belt Pulley
	1217	Oil Seal Φ 45X25X10
	1218	Turbine Back Flange
	1219	Nut M8
	1220	Bearing 6010
	1221	Snap Ring ϕ 50

Motor

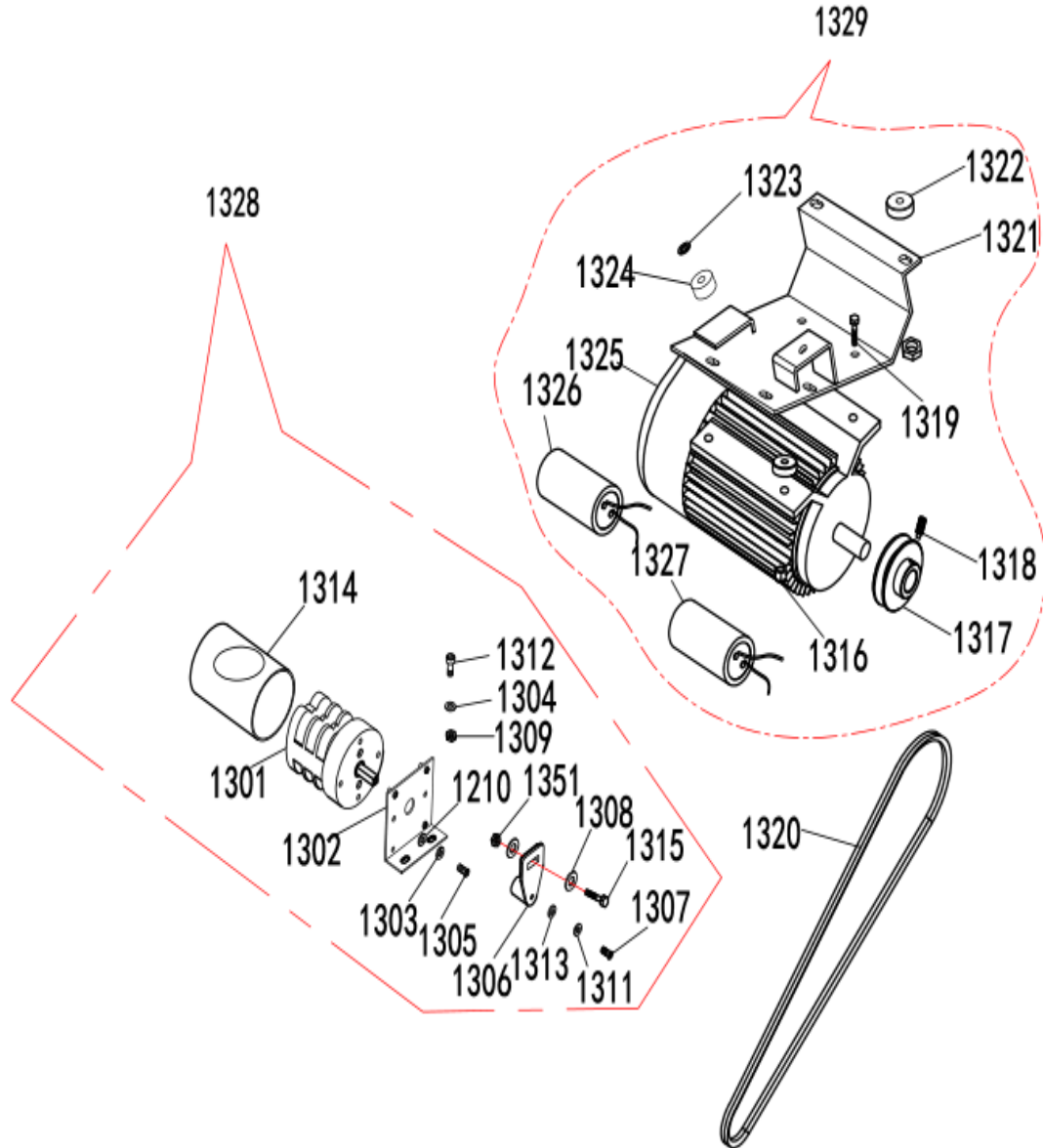

Motor Parts List

Part Number	Item #	Description
5400331	1301	Turntable Direction Switch
	1302	Directional Switch Bracket
	1303	Spring Washer ϕ 5
5400913	1304	Washer ϕ 6
	1305	Cross recessed round head screw M5X16
5400324	1306	Turntable Direction Switch Cam
	1307	Cross recessed round head screw M4X20
	1308	Pad ϕ 6
	1309	Lock Nut M8
	1310	Washer ϕ 5
	1311	Spring Washer ϕ 4
	1312	SHCS M6x16
	1313	Washer ϕ 4
	1314	Directional Switch Cover
	1315	HHB M8x35
	1316	Lock Nut M8
	1317	Motor Pulley
	1318	Hexagon socket set screw with flat end
	1319	HHB M8x40
5327612	1320	Belt A610
	1321	Motor base unit weldment
5400249	1322	Rubber washer
	1323	Pad ϕ 10
	1324	Rubber washer
5327185	1325	Motor
	1326	Start capacitor
5327819	1327	Capacitor
	1328	Turntable Direction Switch Assy.
	1329	Motor Assy.

Rotary Valve

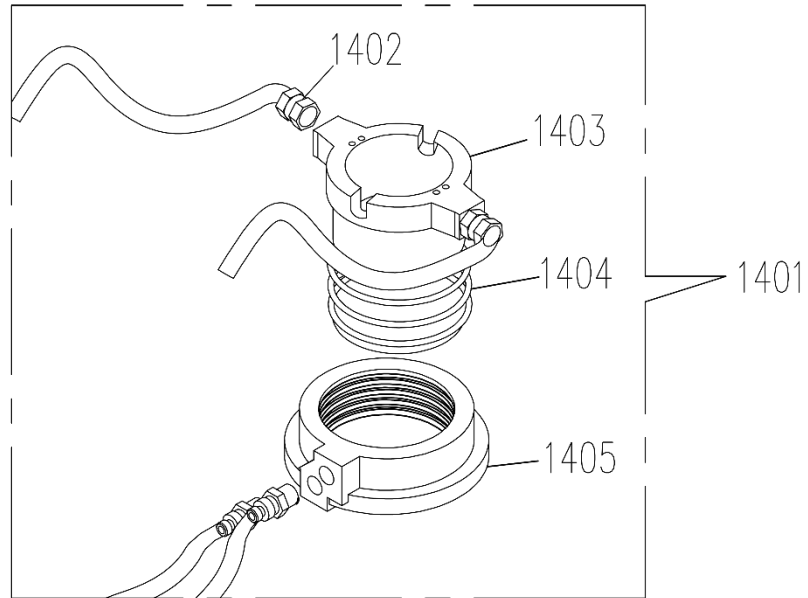

Rotary Valve

Parts List

Part Number	Item #	Description
5327175	1401	Rotary Valve
5327745	1402	Fitting G1/8" ϕ 8
	1403	Rotary Joint Block Inner Piece
	1404	O-Ring ϕ 60 x 2.65
5327355	1405	Rotary Joint Block Outer Piece

Foot Pedals

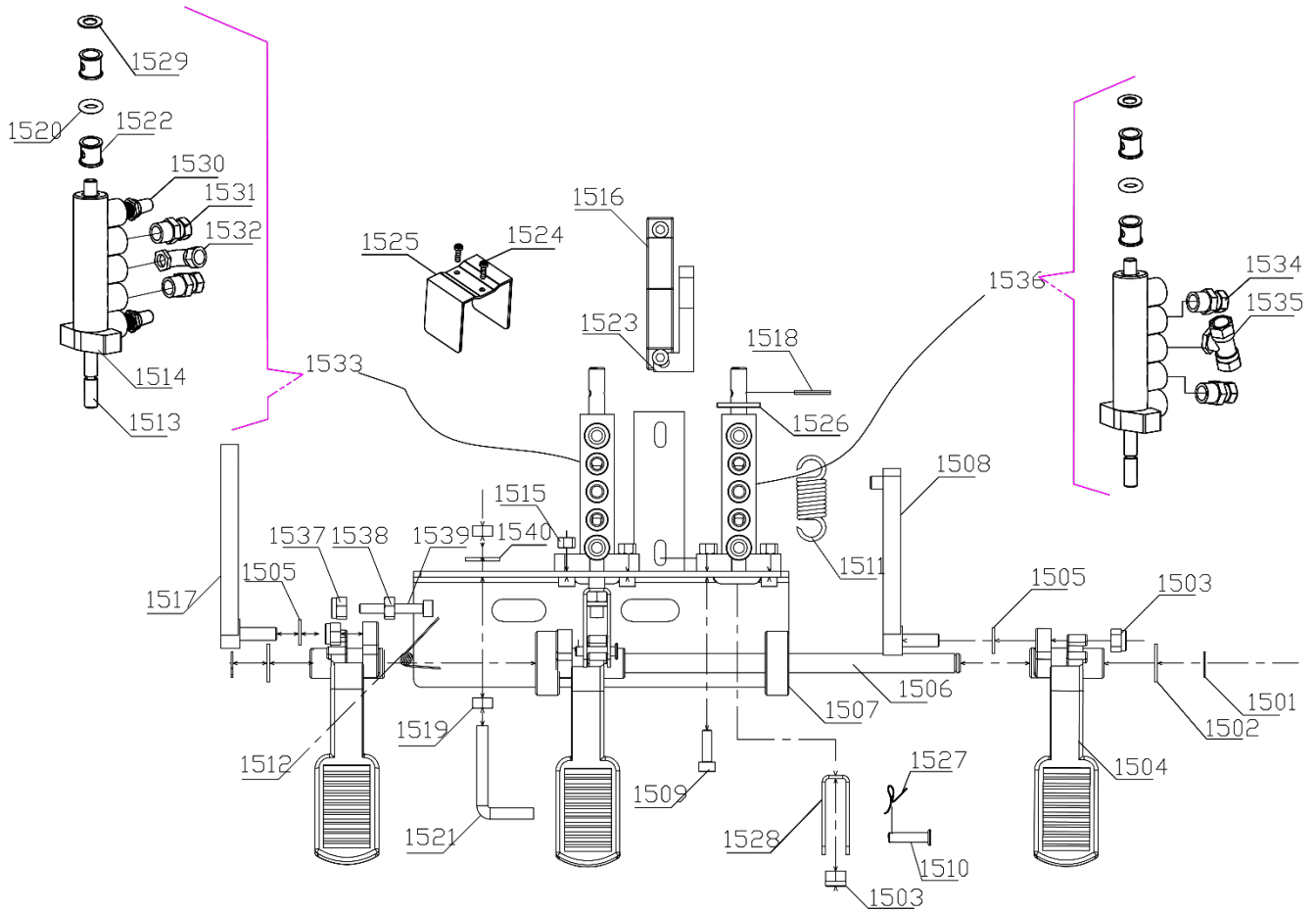

Foot Pedal Parts List

Part Number	Item #	Description
	1501	Shaft Ring ϕ 12
	1502	Washer ϕ 12
	1503	Lock Nut M8
	1504	Foot Pedal
	1505	Washer ϕ 8
	1506	Foot Pedal Shaft
	1507	Baseplate Assembly Welding Piece
	1508	CAM Connecting Rod
	1509	SHCS M6x16
	1510	Pin Roll
	1511	Return Spring
	1512	Torsion Spring
	1513	Air Valve Spool
	1514	Air Valve
	1515	Lock Nut M6
	1516	Pedal Cam
	1517	Directional Switch Cam Linkage
	1518	Round Pin 4x16
	1519	Nut M8
5327536	1520	O-Ring ϕ 17x4
	1521	Torsion Spring Bracket
5327482	1522	Air Valve O-Ring Spacer
	1523	Cam Spacer
	1524	Cross Recessed Head Tapping Screw 4.2X12
	1525	Cam Cover
	1526	Washer ϕ 10
	1527	Split Pin
	1528	Air Valve Connecting Link
	1529	Air Valve End Cap
	1530	Silencer G1/8"
	1531	Silencer ϕ 8-G1/8"
	1532	Silencer 90° ϕ 8-G1/8"
	1533	Cylinder air valve assembly
	1534	Silencer ϕ 8-G1/8"
	1535	Equals Tee
	1536	BB cylinder air valve assembly
	1537	Lock Nut M8
	1538	Nut M8
	1539	SHCS M8x70
	1540	Spring Washer ϕ 8

Assist Tower (Model AT26A Only)

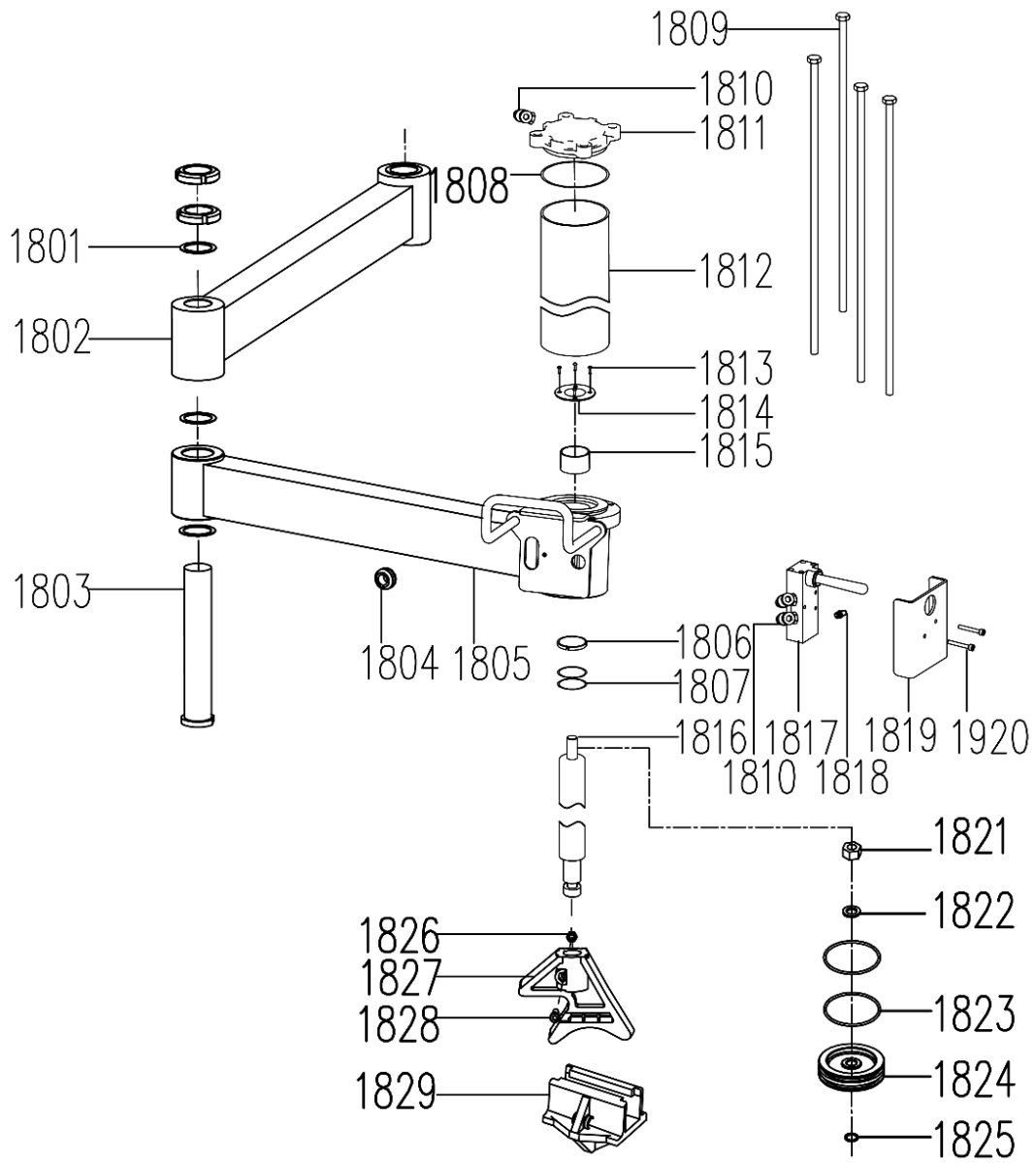

Assist Tower (Model AT26A Only) Parts List

Part Number	Item #	Description
	1801	Interval Pad
	1802	Two Sets of Tumbler Welding Parts
	1803	Shaft (Turn the Arm Shaft)
	1804	A Coil
	1805	A Set of Welding Parts for the Tumbler
	1806	Guidance Tape
	1807	O-Ring $\phi 35 \times 3.1$
	1808	O-Ring $\phi 84 \times 3.1$
	1809	Cylinder Connecting Bolt
	1810	Banjo Bolt G1/8" $\phi 6$ Single
	1811	Cylinder Front Plate
	1812	Cylinder
	1813	Cross Recessed Pan Head Screw M5X12
	1814	Brass Cap
	1815	Bearing
	1816	Cylinder Rod
	1817	Assist Arm Control Valve
	1818	Adjustment Silencer G1/8"
	1819	Hand to Move the Valve Cover
	1820	SHCS M4x30
	1821	Lock Nut M12
	1822	Washer $\phi 12$
	1823	O-Ring $\phi 75 \times 5.7$
	1824	Cylinder Piston
	1825	O-Ring $\phi 16 \times 2.4$
	1826	Nut M6
	1827	Assist Tower Block
5400959	1828	SHCS M6x30
	1829	Restraint Tool (Briquetting)



30440 Agoura Rd.
Agoura Hills, CA 91301 USA
Toll Free: (855) 223-2665
Bendpak.com