

Automatic Wheel Balancer

Installation and Operation Manual

Manual P/N 5900607 — Revision A — Released January 2026

Model:

- AB28

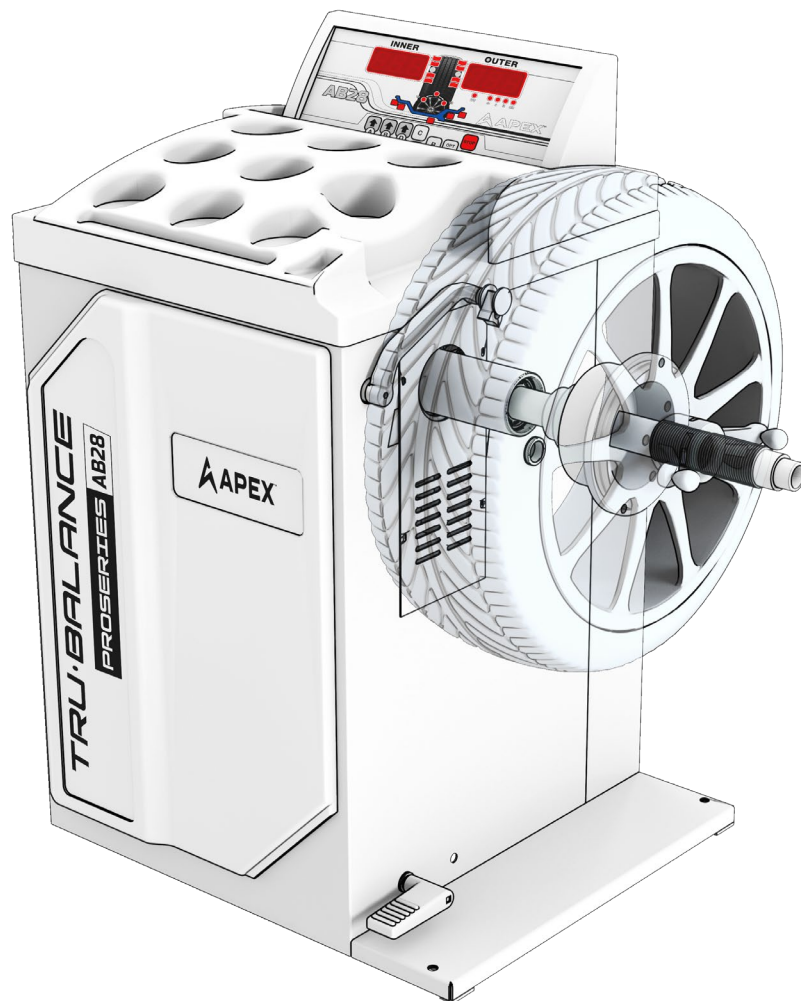

 **DANGER**

Read the *entire contents* of this manual *before* using this product. Failure to follow the instructions and safety precautions in this manual can result in serious injury or death. Make sure all other operators also read this manual. Keep the manual near the product for future reference. **By proceeding with setup and operation, you agree that you fully understand the contents of this manual and assume full responsibility for product use.**

Manual. AB28 Dynamic Wheel Balancing Machine, *Installation and Operation Manual*, P/N 5900607 Revision A, released January 2026.

Trademarks. Copyright © 2026 by APEX, BendPak Inc. All rights reserved. BendPak, the BendPak logo, APEX, and the APEX logo are registered trademarks of BendPak Inc. All other company, product, and service names are used for identification only. All trademarks and registered trademarks mentioned in this manual are the property of their respective owners.

Limitations. Every effort has been made to have complete and accurate instructions in this manual. However, product updates, revisions, and/or changes may have occurred since this manual was published. BendPak APEX reserves the right to change any information in this manual without incurring any obligation for equipment previously or subsequently sold. BendPak APEX is not responsible for typographical errors in this manual. Feel free to contact us at any time to get the latest information about any product: bendpak.com/apex.

Warranty. The BendPak APEX warranty is more than a commitment to you: it is also a commitment to the value of your new product. For full warranty details, contact your nearest BendPak APEX dealer or visit [APEX Product Warranty](#).

Safety. Your new product was designed and manufactured with safety in mind. Your safety also depends on proper training and thoughtful operation. Do not set up, operate, maintain, or repair the unit without reading and understanding this manual and the labels on it; ***do not use this product unless you can do so safely!***

Owner Responsibility. In order to maintain your product properly and to ensure operator safety, it is the responsibility of the product owner ***to read and follow these instructions***.

- Follow all installation, operation, and maintenance instructions.
- Make sure product installation and operation conforms to all applicable local, state, and federal codes, rules, and regulations, such as state and federal OSHA regulations and electrical codes.
- Read and follow all safety instructions. Keep them readily available for operators.
- Make sure all operators are properly trained, know how to safely operate the unit, and are properly supervised.
- Do not operate the product until you are certain all parts are in place and operating correctly.
- Carefully inspect the product on a regular basis and perform all maintenance as required.
- Service and maintain the unit only with approved replacement parts.
- Keep the manual with the product and make sure all labels are clean and visible.
- **Only use this product if it can be used safely!**

Unit Information. Enter the Model Number, Serial Number, and the Date of Manufacture from the label on your unit. This information is required for part or warranty issues.

Model: _____

Serial: _____

Date of Manufacture: _____

Designed and engineered in Southern California, USA.
Made in China.

Table of Contents

Introduction	3	Operation	25
Shipping Information	4	Maintenance	54
Safety Considerations	4	Troubleshooting	55
Components	6	Labels	57
FAQs	9	Parts	59
Specifications	11	Wiring	70
Installation Checklist	12	Maintenance Log	71
Installation	13		

Introduction

This manual describes installation and operation procedures for the APEX Automatic Wheel Balancer Model AB28. The Wheel Balancer detects Wheel imbalances and indicates where counterweights are to be placed to correct the imbalance.

More information about APEX products is available at bendpak.com/apex.

This manual is mandatory reading for all users of the AB28, including anyone who sets up, operates, maintains, or repairs it.

You can always find the latest version of the **manual for your product on the Bendpak website**.

⚠ DANGER Be very careful when installing, operating, maintaining, or repairing this equipment; failure to do so could result in property damage, product damage, injury, or (in very rare cases) death. Make sure only authorized personnel operate this equipment. All repairs must be performed by an authorized technician. Do not make modifications to the unit; this voids the warranty and increases the chances of injury or property damage. Make sure to read and follow the instructions on the labels on the unit.

Keep this manual on or near the equipment so that anyone who uses or services it can read it.

Technical support and service for your Wheel Balancing Machine is available from your distributor or by calling APEX at **(877) 432-6627**. You may also call regarding parts replacement (please have the serial number and model number of your unit available).

Shipping Information

Your equipment was carefully checked before shipping. Nevertheless, you should thoroughly inspect the shipment **before** you sign to acknowledge that you received it.

When you sign the bill of lading, it tells the carrier that the items on the invoice were received in good condition. **Do not sign the bill of lading until after you have inspected the shipment.** If any of the items listed on the bill of lading are missing or damaged, do not accept the shipment until the carrier makes a notation on the bill of lading that lists the missing or damaged goods.

If you discover missing or damaged goods **after** you receive the shipment and have signed the bill of lading, notify the carrier at once and request the carrier to make an inspection. If the carrier will not make an inspection, prepare a signed statement to the effect that you have notified the carrier (on a specific date) and that the carrier has failed to comply with your request.

It is difficult to collect for loss or damage after you have given the carrier a signed bill of lading. If this happens to you, file a claim with the carrier promptly. Support your claim with copies of the bill of lading, freight bill, invoice, and photographs, if available. Our willingness to assist in helping you process your claim does not make us responsible for collection of claims or replacement of lost or damaged materials.

Safety Considerations

Read this manual carefully before using your new product. Do not set up or operate the product until you are familiar with all operating instructions and warnings. Do not allow anyone else to operate the product until they are also familiar with all operating instructions and warnings.

 **WARNING California Proposition 65 Warning.** This product can expose you to chemicals including styrene and vinyl chloride which are on the list of over 900 chemicals identified by the State of California to cause cancer, birth defects or reproductive harm. **ALWAYS** use this product in accordance with BendPak's instructions. For more information go to www.P65Warnings.ca.gov.

 **WARNING** There are moving parts on a Wheel Balancing Machine; keep clear of these moving parts and the Wheel being balanced. **Never** engage the machine while in contact with the Wheel or tire; **do not** touch the Wheel *while* it is rotating. Serious injury may result if you come into contact with a rapidly spinning Wheel.

Safety Information





Please note the following:

- This product is a Wheel Balancing Machine. **Use it only for its intended purpose.**
- The product **must** only be operated by authorized, trained, properly supervised personnel. Keep children and untrained personnel at least 30 feet away from the product when it is in use.
- Always follow all applicable local, state, and federal codes, rules, and regulations, including (but not limited to) OSHA standard 1910.177 (Servicing multi-piece and single piece rim Wheels).
- You **must** wear OSHA-approved (publication 3151) Personal Protective Equipment at all times when installing, using, maintaining, or repairing the Wheel Balancing Machine. Leather gloves, steel-toed work boots, eye protection, back belts, and hearing protection **are mandatory.**

-
- Do not use the product while tired or under the influence of drugs, alcohol, or medication.
 - Do not use the product in the presence of cigarette smoke, dust, or flammable liquids or gases. Use the product indoors in a well-ventilated area.
 - Do not make any modifications to the product; this voids the warranty and increases the chances of injury or property damage. **Do not modify any safety-related features in any way.**
 - Make sure all Operators read and understand this Installation and Operation Manual. Keep the Manual near the Wheel Balancing Machine at all times.
 - Make a visual inspection of the Wheel Balancing Machine every day. Do not use the product if you find any missing or damaged parts. Instead, take the Wheel Balancing Machine out of service, then contact an authorized repair facility, your distributor, or APEX at **(877) 432-6627**.
 - APEX recommends making a **thorough** inspection of the product once a month. Replace any damaged or severely worn parts, decals, or warning labels.

Symbols

Following are the symbols used in this Manual:

-  **DANGER** Calls attention to an immediate hazard that **will** result in death or severe injury.
-  **DANGER** Calls attention to an electrical hazard that **will** result in death or severe injury.
-  **WARNING** Calls attention to a hazard or unsafe practice that **could** result in death or injury.
-  **CAUTION** Calls attention to a hazard or unsafe practice that could result in minor personal injury, product damage, or property damage.
- NOTICE** Calls attention to a situation that, if not avoided, could result in minor personal injury, product, or property damage.
-  **Tip** Calls attention to information that can help you use your product better.

Liability Information

APEX assumes **NO** liability for injury, death or damages resulting from:

- Use of this equipment for purposes other than those described in this Manual.
- Modifications to the equipment without prior, written permission from APEX.
- Modifying, disabling, overriding, or removing safety features.
- Damage to the equipment from external influences.
- Incorrect operation of the equipment.

Components

- **Display and Control Panel.** Controls the Wheel Balancer and displays the Balancer test results.
- **Trays.** Stores weights and tools for balancing.
- **Shaft.** Rotates and supports the Wheel.
- **Brake Pedal.** Stops the Shaft rotation.
- **Cone Hangars.** Stores the Wheel cones not currently in use.
- **Quick Nut.** Secures the Wheel to the Shaft.

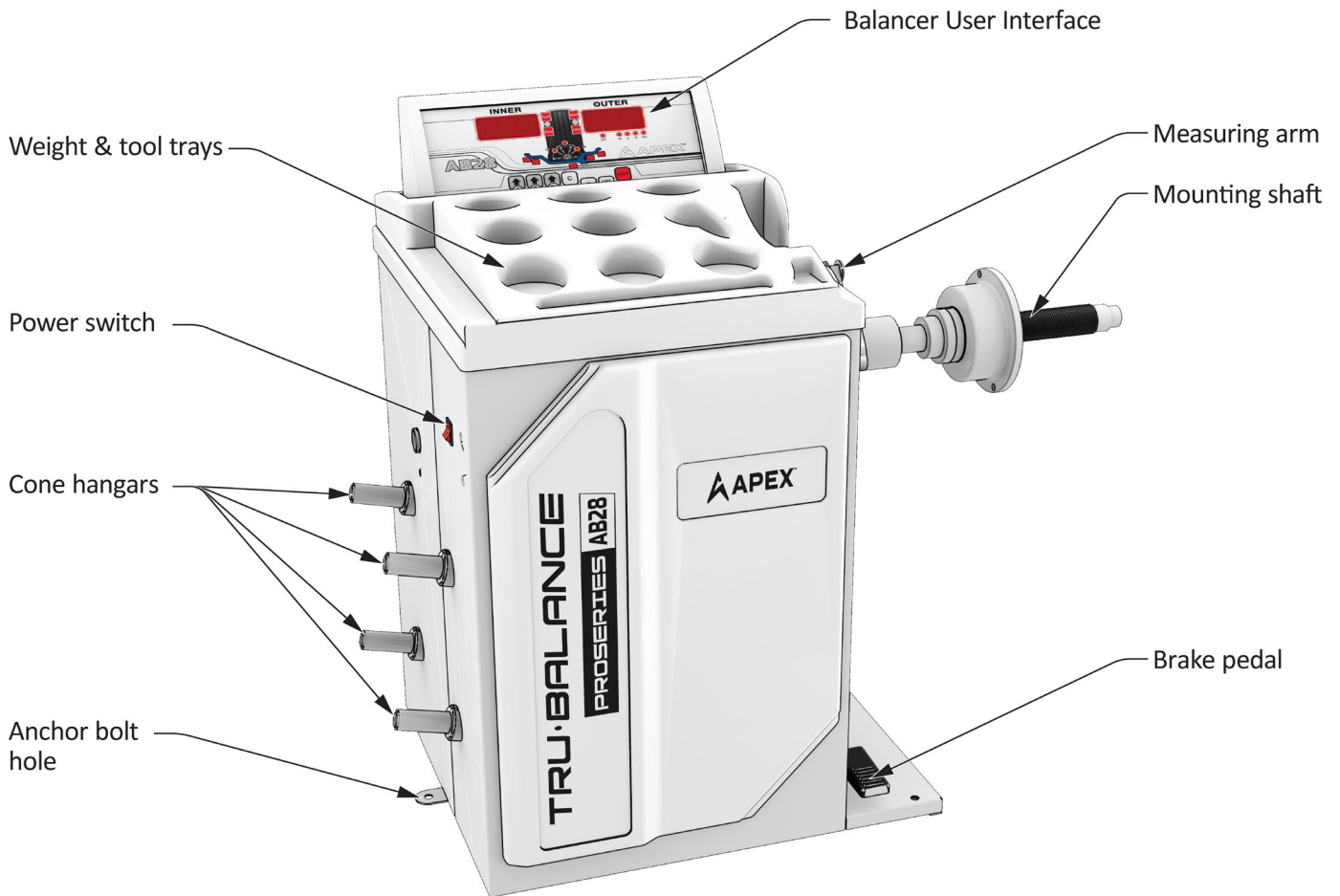

Not all components visible in illustration; not to scale.

- **Tire Cover.** Covers the Wheel while in motion.
- **Power On-Off.** Removes power from the Balancer.
- **Anchor Bolt Holes.** Used to anchor the Balancer
- **Inner Distance Arm.** Measures the distance from the side of the Balancer to the inside of the Wheel.
- **Quick Nut.** Holds the Wheel on the Shaft.
- **Mounting Cones and Cups.** Supporting a wide range of tire sizes.
- **Caliper.** Used to measure the Wheel width.
- **Spacer Ring.** Used for larger Wheels only.

Balancer Accessories Included: (Stored in a box under the Balancer during shipping.)

- **Quick-Release Nut.** Holds the Wheel on the Balancer Shaft when the Wheel is mounted.
- **Hex Key Wrench Set.** Used during installation. Hex key wrenches are sometimes called Allen® wrenches.
- **Anchor Bolts.** Expansion bolts are included to anchor the Balancer to the floor at the desired location. Anchoring the Balancer is strongly recommended.
- **Wheel Weight Tool.** Used to install and remove clip-on Wheel weights.
- **Weight Removal Tool.** Used to remove Adhesive Weights.
- **Mounting Spring.** Secures the Wheel when using rear and dual-cone mounting.
- **Inner and Outer Calibration Weights.** Used to calibrate the Balancer.
- **Mounting Cone Assortment.** Supports a wide range of Wheel sizes.
- **Calipers.** Used to measure the Wheel width.

Terms to Know

- **Wheel.** A circular metal component designed to accept a Tire mounted on its circumference and attaches to an axle allowing rotation.
- **Tire.** A circular rubber piece that surrounds and attaches to a Wheel; more specifically, to the Rim, the part of the Wheel that directly touches the Tire.
- **Rim.** The part of a Wheel that directly attaches to a Tire; almost always the outer portion of the Wheel. Because modern Wheels are frequently created from a single piece of metal, “Wheel” and “Rim” are sometimes used interchangeably.
- **Imbalance.** An unbalanced weight distribution in a Wheel; it can cause vibration. To correct an imbalance, a weight must be applied **opposite** the imbalance.
- **Planes.** When a Wheel is figuratively divided down the middle into two sections, it creates two planes; called Inner and Outer. Balancing is more effective when planes are analyzed for imbalance separately (and addressed separately), called Dynamic Balancing.
- **Clip-On Weights.** Metal weights that are held in place on the Wheel by clipping them to the Inner or Outer Edge. Older Clip-On Weights made of lead should **not** be used as they are a hazard to the environment; they are also illegal to use in many countries and some states in the U.S. The Clip-On Weights delivered with the Balancer are **not** made of lead.
- **Adhesive Weights.** Weights that are flat and held in place with adhesive; they get placed on the Inner, Outer, or Center Plane. Adhesive Weights come in both black and gray, making them harder to see and thus not interfering with the attractiveness of the Vehicle’s Wheels/Rims.
- **Placement Indicators [on display panel].** Light up when the best weight location is reached.
- **Balancing Modes.** The Balancer supports Dynamic, Aluminum, and Static Balancing.
- **Dynamic Balancing.** Balancing a steel Wheel where each of the two planes are analyzed separately. If there is an imbalance, the two planes are brought back into balance separately. Dynamic Balancing is a more recent technology than Static Balancing and generally produces a better balance.
- **Static Balancing.** Balancing a Wheel as a whole; that is, on a single plane only. This is an older method of balancing and is generally not as effective as Dynamic Balancing. Static Balancing is required for motorcycle Wheels and older Wheels that are 4 inches wide or less; also used if only Adhesive Weights can be attached on the Center Plane of the Wheel.
- **Aluminum Alloy Balancing.** Balancing Wheels made of aluminum alloy. The Weights are placed differently on these Wheels, so you need to know where you want to put the Weights and select the appropriate ALU Mode. ALU Modes generally use Adhesive Weights, which are less visible than Clip-On Weights.

Frequently Asked Questions

Question: What does a Wheel Balancing Machine do?

Answer: The Wheel Balancer detects Wheel imbalances and indicates where and what value of counterweights are to be placed to correct the Wheel imbalance. Wheel imbalance creates vibration which creates excessive wear on the tires and steering components.

Q: Is Wheel Balancing the same as Wheel Alignment?

A: No. When you *balance* a Wheel, you fix a weight distribution problem that can cause Wheel wobble, uneven tire wear, and vehicle vibration. This is done by putting weights on the Wheel in appropriate locations.

When you *align* a Wheel, you are adjusting the angles of the Wheels to the pavement through the vehicle suspension.

Q: Where can I put my Wheel Balancer?

A: The ideal location has a flat concrete floor with room to move the Wheels and tires safely around the machine. The Balancer's position should allow the operator to work safely and keep everyone away from the Balancer while it is in use. Most garages put their Wheel Balancers and Tire Changers near each other.

Q: Why are there two types of Weights?

A: Clip-On Weights are more visible. Adhesive Weights are lower profile and come in two colors so you can try to color match with the Rim, so they are less visible. Some Vehicle owners with expensive Wheels prefer Adhesive Weights because they are less visible.

Q: What kind of electrical plug comes with the Balancer?

A: The Balancer comes from the factory with a plug for 115 VAC power. However, it is switchable to 230 VAC. Refer to **Connecting to Power** for complete instructions for switching between 115 and 230 VAC. Because 230 VAC plugs vary from location to location, no 230 VAC plug comes with the Balancer. Have a *Licensed Electrician* refer to this manual for instructions on converting the Balancer to 230 VAC. The Electrician will also install an appropriate plug or have the Power Cord attached directly to the facility's power system protected by an appropriate circuit breaker conforming to local electrical codes.

Q: What Balancing Modes does the Balancer include?

A: The Balancer has six dynamic balancing modes and one static mode. Dynamic modes are DYN, ALUS, ALU 1, ALU 2, ALU 3, ALU 4, and ALU 5. Dynamic (DYN) mode is used with steel Wheels, the Static mode is used for older, narrower Wheels or motorcycle Wheels, and the Aluminum modes are for Aluminum Alloy (non-steel) Wheels.

Q: How accurate are the weight values the Balancer displays?

A: By default, the Balancer rounds off to .25 ounces (~7 grams); this is because most weights sold in the U.S. come in .25 ounce increments. (Countries that use the metric system measure weight in grams; their weights come in 5 gram increments.) If you do not want rounded-off weight values, press and hold the **F** button on the Control Panel to see specific values.

Q: What do I do if I have a problem with the Balancer that I cannot solve?

A: Contact APEX; we are here to help. Using a web browser, visit the **APEX Support website**.

AB28 Dimensions

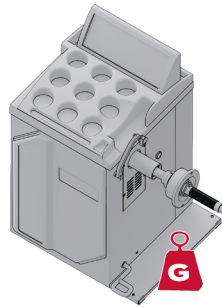
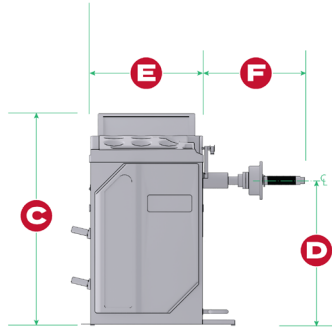
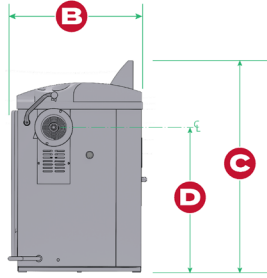
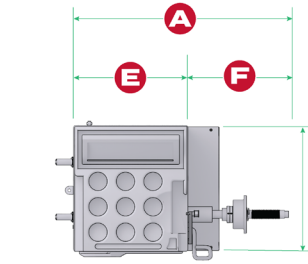

- A** Overall Length: 40.2 in. (1020 mm)
- B** Case Depth: 22.8 in. (585 mm)
- C** Case Height: 38.6 in. (980 mm)
- D** Arbor / Spindle CL Height: 26.9 in. (685 mm)
- E** Case Length: 20.9 in. (530 mm)
- F** Arbor / Spindle Assy Length: 27.1 in. (690 mm)
- G** Weight: 389 Lb. (177 kg)

Specifications Model AB28

Specifications	Performance
Maximum Wheel Weight	150 lbs./68kg
Min.-Max. Rim Diameter	10 – 26 in. (256 mm – 660 mm)
Min. Max. Wheel Width	1.5- 20 in. (38 mm – 508 mm)
Balance Precision	±1g (.035 oz.)
Balance Speed	≈260 rpm
Position Accuracy	1.5
Cycle Time	≈7s
Power Supply	115-230 VAC, 50/60 Hz 1 Ph.* 0.25 kW
Power Cord Length	60 in. Min. (1,524 mm Min.)
Current	.25kW
Drive System Type	Electric Belt Drive
Noise	<70dB
Net Weight	112kg 246 lbs. (No Shaft fixture or external scale)
Gross Weight	389 lbs. (177 kg)
Dimensions:	
Length	40.2 in. (1020 mm)
Depth	22.8 in. (585 mm)
Height	38.6 in. (980 mm)
Operating Temperature	41° F to 122° F (+5° to +50°C)
Relative humidity	85% Non-Condensing

*Delivered from the factory configured for 115 VAC operation. The Balancer may be switched to 230 VAC. Refer to **Connecting to Power** for instructions; Licensed Electrician is required to switch the Balancer to 230 VAC.

Specifications subject to change without notice.

Installation Checklist

Following are the steps needed to install the Wheel Balancing Machine. Perform them in the order shown.

- 1. Unpack and verify that all parts are accounted for and undamaged.
- 2. Review the installation Safety Rules.
- 3. Verify that there is a power source available at the installation location. Make arrangements for an electrician, if required.
- 4. Make sure you have the necessary Tools.
- 5. Make sure there is adequate clearance around and above the AB28.
- 6. Unpack the Components.
- 7. Connect the matcher to the Balancer shaft.
- 8. Install the tray and control panel.
- 9. Move the Balancer to its permanent Location.
- 10. Anchor the Balancer.
- 11. Install the Tire Cover.
- 12. Connect to Power. This will require a *licensed electrician* if you are converting to 230 VAC.
- 13. Test the Balancer. See **Balancer Testing**.

Installation

This section describes how to install the APEX Wheel Balancer. Perform the tasks in the order presented.

Installation Safety Rules

Pay attention at all times during installation. Use appropriate tools and equipment. Stay clear of moving parts. Keep hands and fingers away from pinch points. ***Safety is your top priority.***

Use caution when unpacking the Wheel Balancing Machine from its shipping container and setting it up. The Wheel Balancing Machine is heavy and the weight is not evenly distributed; dropping or knocking over the unit may cause equipment damage and personal injury.

⚠ WARNING You **must** wear OSHA-approved (publication 3151) Personal Protective Equipment at all times when installing, using, maintaining, or repairing the Wheel Balancing Machine: leather gloves, steel-toed work boots, eye protection, back belts, and hearing protection are **mandatory**.

Only experienced, trained technicians may install the Wheel Balancing Machine. In particular, all electrical work **must** be done by a **licensed, certified Electrician**.

⚠ CAUTION Certain parts of installing the Wheel Balancing Machine are difficult for one person. APEX strongly recommends having two or more people work together to install the unit.

If an extension cord is required to power the Balancer, verify that its current rating is equal to or greater than that of the equipment being used. Make sure the extension cord cannot be stepped on, run over, or pulled out. Extension cords are also a tripping hazard, secure them appropriately.

Plan for Electrical Work

The Balancer comes with a power cord pre-wired for 115 VAC. Verify a 115 VAC outlet is near the Balancer site.

If you plan to use 230 VAC, contact a licensed Electrician to verify that the facility electrical system is up to local electrical code and that the 230 VAC can be provided at the planned Balancer site. The Electrician will also provide guidance on using a plug or connecting directly to the facility electrical system through a circuit breaker.

⚠ WARNING All electrical work, such as attaching a plug to the power cord or connecting directly to the facility power system must be completed by a **licensed Electrician in accordance with all applicable national, state and local electrical codes**. Refer to **Connecting to Power** for instructions.

Tools

You may need some or all of the following tools:

- Forklift, pallet jack, or shop crane
- Scissors, utility knife or other cutting tool.
- Hammer, mallet, crow bar, or pry bar
- Hex key and wrench set, metric and SAE
- Screwdriver set, slot and Phillips
- Hammer drill and masonry drill bit

Finding a Location

Keep the following in mind when deciding on a location for your Balancer:

- **Power Source.** The Wheel Balancing Machine needs to be near an appropriate 115 or 230 VAC power source.
- **Floor.** The Wheel Balancing Machine requires a flat, concrete floor.
- **Clearance.** The AB28 needs space around it. Refer to **Clearance** for more information.
- **Access.** You need some space to move Wheels to and from the Wheel Balancing Machine.
- **Danger.** When the Wheel Balancing Machine is in use, especially during Balancing, you need to keep everyone away from it. Only the Operator should be within 30 ft. (9 m) of the Wheel Balancing Machine when it is in use.

Do not set-up the Wheel Balancing Machine in a well-travelled area.

- **No Water.** The Wheel Balancing Machine has electronic components. If the Wheel Balancing Machine gets wet while power is connected, those electronic components may short circuit and require replacement.

 **WARNING** ***Do not use the Wheel Balancing Machine if it is in water.*** You will short circuit the electronic components in the Wheel Balancing Machine and you could electrocute yourself or bystanders.

Clearance

Clearance around and above the equipment is *required* for safety.

Provide adequate clearance around the equipment to ensure safe operation and service access. Surrounding equipment, walls, and structural elements should be arranged to allow free and unobstructed movement of personnel and service equipment such as oil drains, tool carts, and other shop apparatus through adjacent work areas and access lanes.

Auxiliary and utility services should be routed so they do not interfere with lift operation or prevent removal of access covers or service panels.

⚠ WARNING The Clearance values shown below allow enough space to operate the Wheel Balancing Machine. **However, for safety purposes, only the Operator should be within 30 feet of the Wheel Balancing Machine while it is in use.**

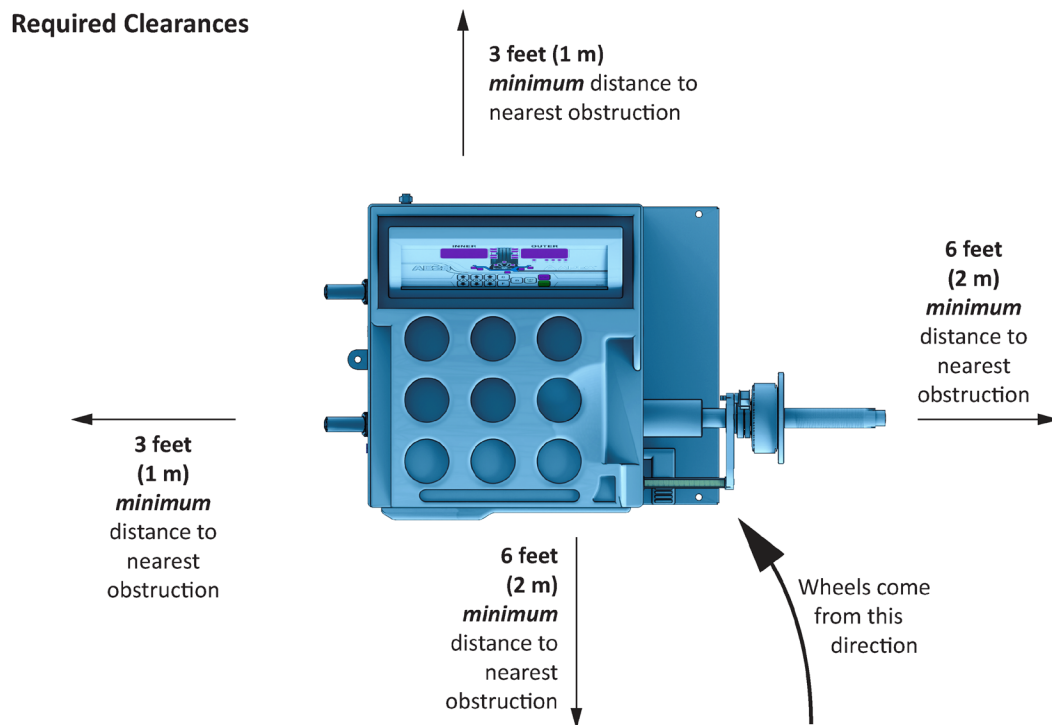

Top view. Not to scale. Not all components shown.

Unpacking

APEX recommends unpacking the Wheel Balancing Machine as close as possible to its permanent location. The less you have to move things around, the smoother your unpacking and installing will be.

Note: Many of the Wheel Balancing Machine components have been greased for shipping. APEX recommends having shop towels nearby when unpacking.

Use caution when taking the Wheel Balancing Machine out of its shipping container.

You do not want to damage the unit, misplace any of the components that come with it, or hurt anyone.

To unpack the Wheel Balancing Machine:

Make sure you are wearing OSHA-approved (publication 3151) Personal Protective Equipment: leather gloves, steel-toed work boots, back belts, hearing protection, and ANSI-approved eye protection (safety glasses, face shield, or goggles).

⚠ CAUTION Make sure to use an appropriate lifting device, such as a Forklift or Pallet Jack, to move the Balancer while it is on its pallet. Make sure only personnel who are experienced with material handling procedures are allowed to move the Balancer. The Balancer is heavy and the weight is not evenly distributed; dropping or knocking over the unit may cause equipment damage or personal injury. **Do not lift the Balancer by the Shaft Housing; you will damage it.**

1. The Wheel Balancer is attached to a pallet and protected with a thin wood Cover. At the **bottom of the Cover**, use a Pry Bar or Screwdriver to push the metal tabs all the way down, on all four sides.



Tip

You *may* have to apply some force to get all of the metal tabs free; *they sometimes stick*. Refer to the figure below.

2. Use a Pry Bar or Hammer to bend the metal tabs on **all four sides of one panel**. Refer to the figure below.
3. Remove that one panel.
4. Rotate the Cover off and set aside.

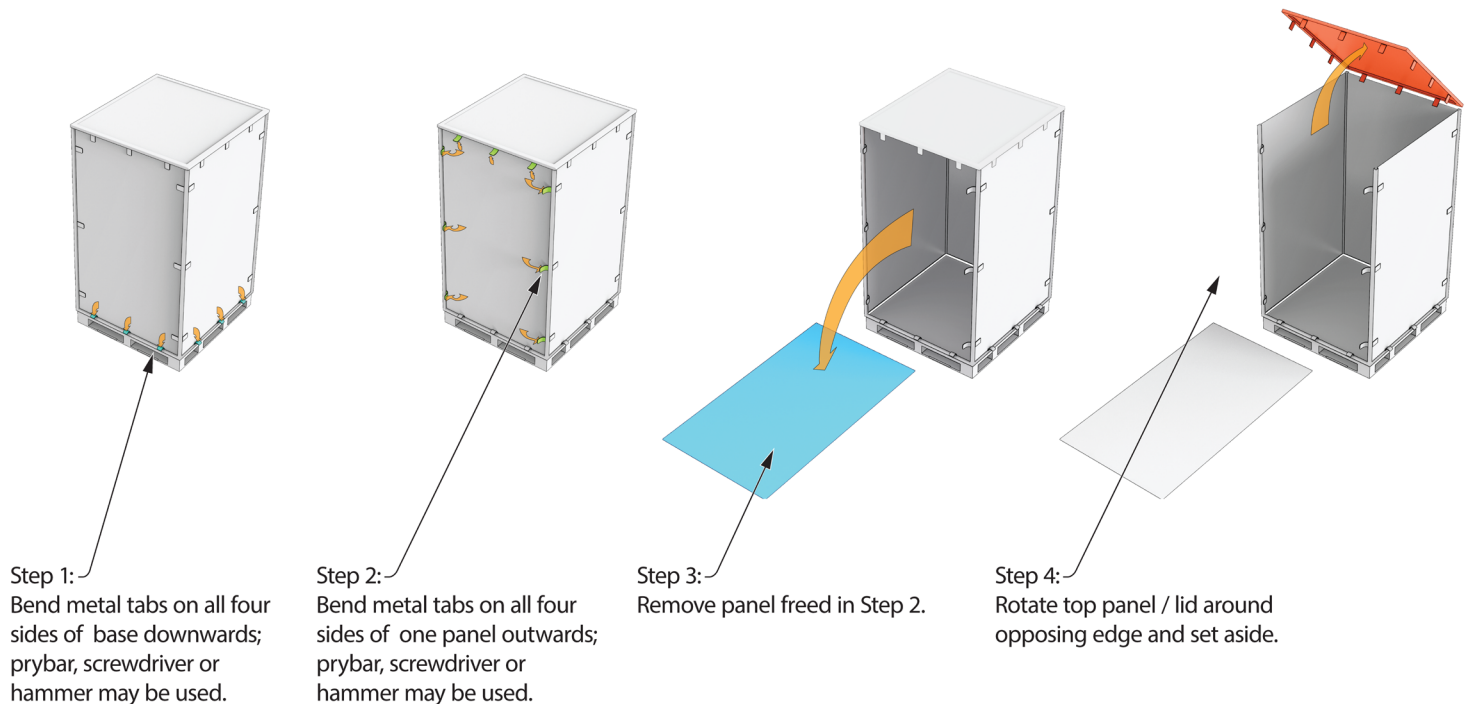

5. Remove the plastic wrap, cardboard pieces and other shipping components around the Balancer.
6. Remove the shipping bolts holding the Balancer to the pallet.

7. Carefully tilt the Balancer, then remove the Accessory Box from inside the Balancer Cabinet.

Step 7:

Carefully tilt the balancer to retrieve the accessories and parts stored beneath / inside



If there seem to be missing parts - **STOP**.
Check **beneath / inside** the balancer!

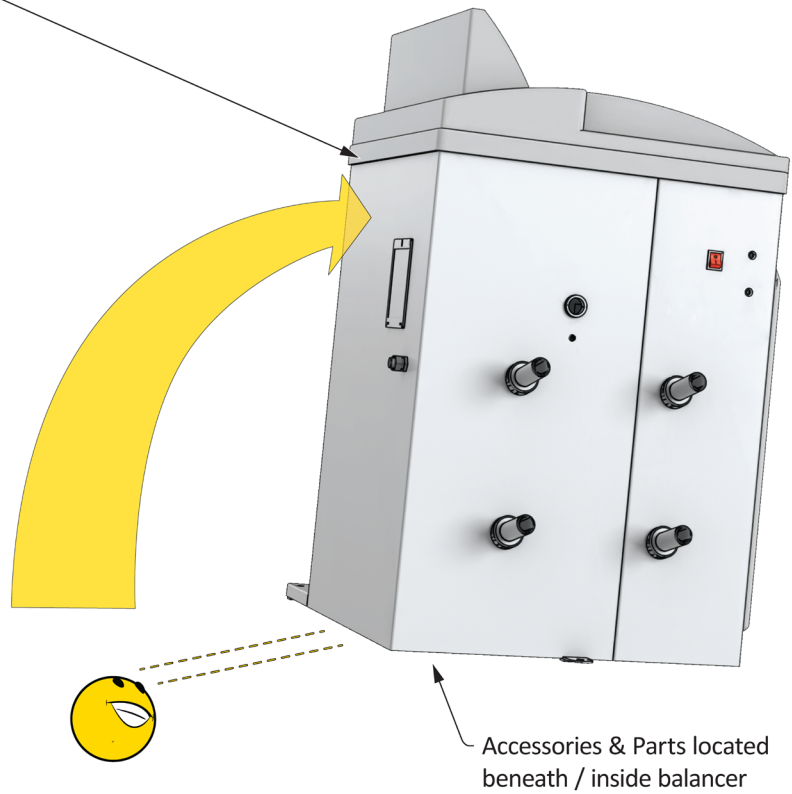

8. Move the Balancer off the pallet, then move it to the desired location.

Important: *Do not* lift or move the Balancer by the shaft or shaft housing. It will not support the Balancer's weight and will result in **damage** to the Balancer.



IMPORTANT

NEVER use the wheel balancer main shaft as a lifting, pulling, or handling point during unloading or installation. The main shaft is **directly coupled** to internal piezoelectric sensors.

Applying lifting or side loads to the shaft can **damage** these sensors, resulting in calibration failure, inaccurate balance readings, or permanent internal damage, **and a voided warranty**.

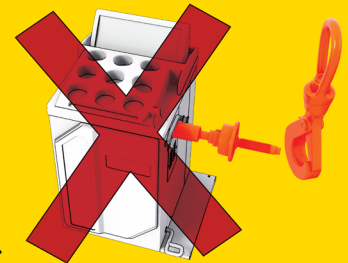

Installing the Shaft

1. Make sure you are wearing OSHA-approved (publication 3151) Personal Protective Equipment: leather gloves, steel-toed work boots, back belts, hearing protection, and ANSI-approved eye protection (safety glasses, face shield, or goggles).
2. **Carefully** clean the threaded shaft and the center hole of the shaft housing using alcohol or equal.
3. To attach the shaft housing to the threaded shaft using a SCHS M14 x 240 and a 10 MM hex key, look for a "0" on the surface of the shaft housing and on the threaded shaft. **Carefully** align these "0" marks so that they are in line: this being correct is **critical** to proper operation of the balancer.



IMPORTANT

Mating the Threaded Shaft to the Shaft Housing is a **critical** part of the assembly process. The **alignment / witness** marks are stamped into the components to **ensure** precise alignment, leading to accurate balance readings.

Align **carefully!!**

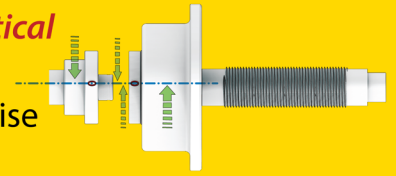

Shaft installation

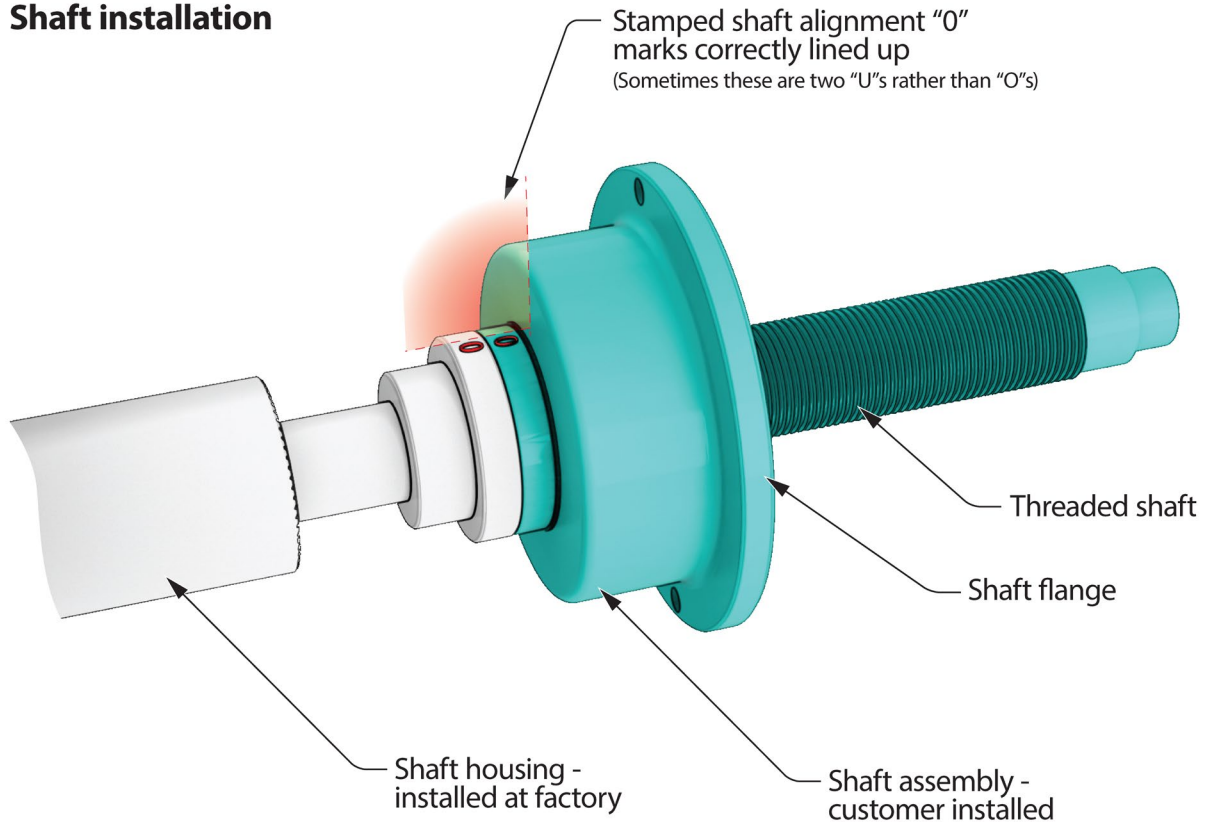

Installing the Cone Hangars, Tray, and Display

The four Cone Hangars are attached with SCHS M6 x 25 with a washer, split-ring lock washer and M6 hex nut. The parts Tray and Display is integrated into one assembly. It is attached to the Balancer cabinet through six M6 x 20 Hex Socket Head Screws and M6 Clip Nuts. The Clip Nuts slide over the edge of the cabinet lined up with predrilled holes that match the position of the openings on the Tray.

Install the six Clip Nuts on the cabinet and place the tray over the cabinet. Secure with the six M6 x 20 Hex Socket Head Screws. Do **NOT over-tighten the screws**. Cracking of the plastic tray will result.

Take care to not pull or damage the wiring harness (or ribbon cable) or its connections between components and the display panel.

See figure below.

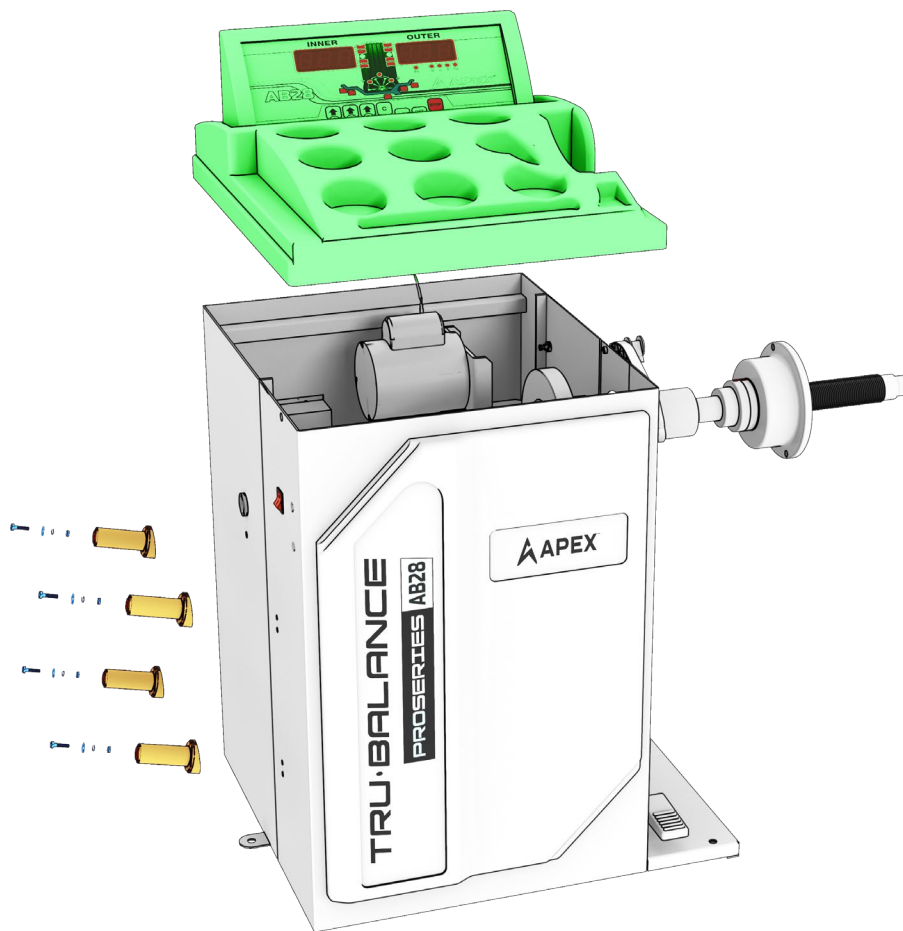

Anchoring the Wheel Balancing Machine

The Wheel Balancing Machine has three openings for anchoring. Anchoring ensures it will not move during operation. Three M8 x 100 Expansion Anchors are included in the accessory kit with the Balancer.

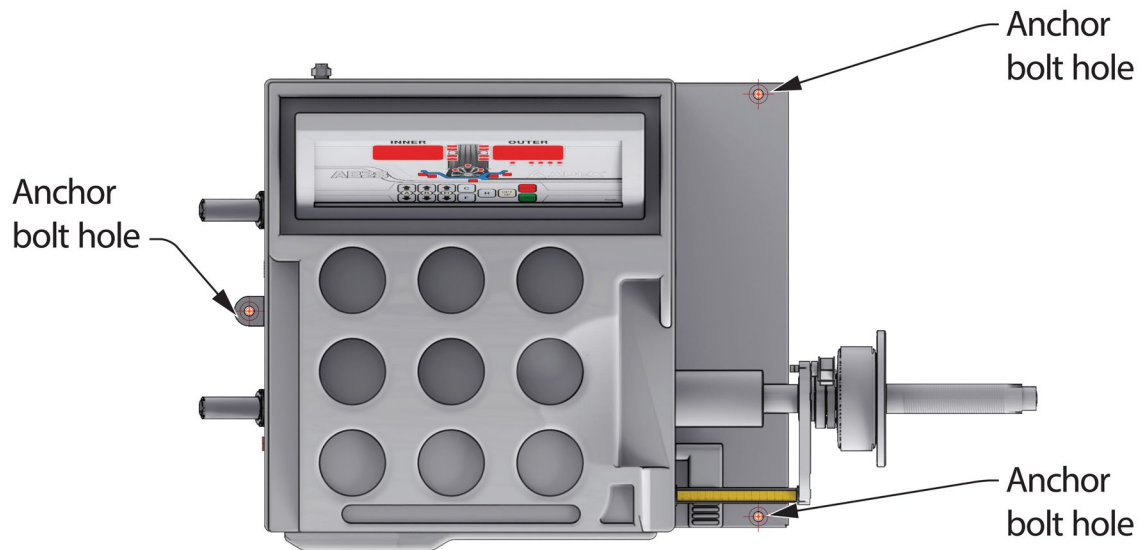

The M8 x 100 Expansion Anchors (sometimes called Wedge Anchors) mentioned in the following procedure are supplied with the Wheel Balancing Machine.

To anchor the Wheel Balancing Machine:

1. Make sure you are wearing OSHA-approved (publication 3151) Personal Protective Equipment: leather gloves, steel-toed work boots, back belts, hearing protection, and ANSI-approved eye protection (safety glasses, face shield, or goggles).
2. Make sure the Wheel Balancing Machine is in the desired location.
3. Using the holes as guides, drill the holes for the Anchor Bolts.

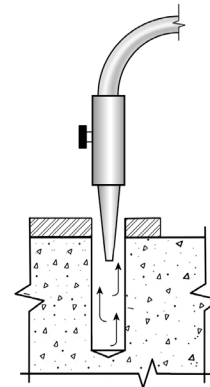
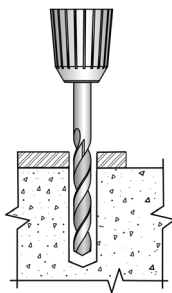

Go in straight; do not let the drill wobble. Use a carbide-tipped masonry drill bit (conforming to ANSI B212.15).

Use a drill bit that is the same diameter as the Anchor Bolt. So, if you are using an 3/8 in diameter Anchor Bolt, for example, use a 3/8 in diameter drill bit.

4. Vacuum each hole to remove debris APEX recommends using a wire brush and a vacuum to get the hole very clean.

Do **not** ream the hole. Do **not** make the hole any wider than the drill bit made it.

5. Place the washer on the anchor and thread the nut partially down the anchor, then insert the Anchor Bolt into the hole.

Note: The Expansion Sleeve of the Anchor Bolt may prevent the Anchor Bolt from passing through the hole in the base of the Wheel Balancing Machine; this is normal. Use a hammer or mallet to get the Expansion Sleeve through the base and down into the hole.



Even using a hammer or mallet, the Anchor Bolt should only go into the hole part of the way; this is normal. If the Anchor Bolt goes all the way in with little or no resistance, the hole is too wide.

Once past the hole in the base, the Anchor Bolt eventually stops going down into the hole as the Expansion Sleeve contacts the sides of the hole; this is normal.

6. Hammer or mallet the Anchor Bolt the rest of the way down into the hole. Stop when the Washer is snug against the base of the Wheel Balancing Machine.
7. Use a torque wrench to tighten each Nut *clockwise* to 55 lbf-ft.

Important: Do *not* use an impact wrench to torque the Anchor Bolts. Wrenching the Nut forces the Wedge up, forcing out the Expansion Sleeve and pressing it tightly against the Concrete.

Connecting to Power

⚠ DANGER This Wheel Balancing Machine uses electrical energy; if your organization has Lockout/Tag-out policies, implement them once the unit is connected to power. Verify the Wheel Balancing Machine is disconnected from the power source before any electrical work is attempted.

⚠ DANGER *All* electrical work (including changing a Plug from 115 VAC to 230 VAC) must be done by a **licensed Electrician in accordance with all local, state and national electrical codes**. If you do not use a licensed, certified Electrician, you void your warranty and put everyone who uses the Wheel Balancing Machine in danger of injury or, in rare cases, death.

The AB28 comes with a Power Cord that is connected internally on one end and connected to a 115 VAC electrical Plug. It can also be re-wired by a licensed Electrician to a 230 VAC plug, and protected by an appropriately rated circuit breaker or fuse.

The colors of the three exposed wires from the power cord are Brown, Blue, and Green/Yellow, the European color code.

Important: To connect the three exposed wires to an appropriate Plug or to hard-wire them, have your Electrician follow the electrical codes for the country and locality in which you are using the unit.

For example, if you are using the unit for 230V in the United States, the color codes of the power cord wiring on the AB28 correspond to:

Brown: Live

Blue: Live

Green/Yellow: Ground

If you were using the unit in a European country, the color codes on the wiring that comes with the AB28 correspond to:

Brown: Live

Blue: Neutral

Green/Yellow: Ground

Information about color code conventions in other regions and countries is available online. Make sure your Electrician installs the Plug in accordance with all applicable local electrical codes.

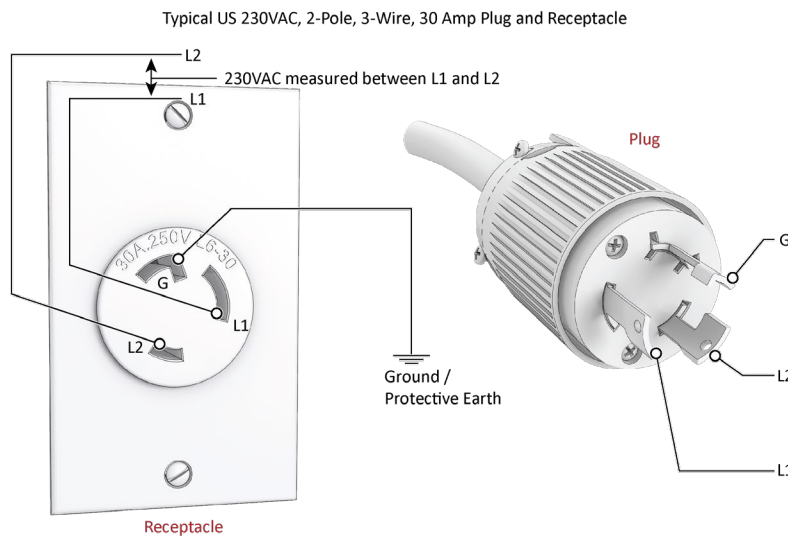
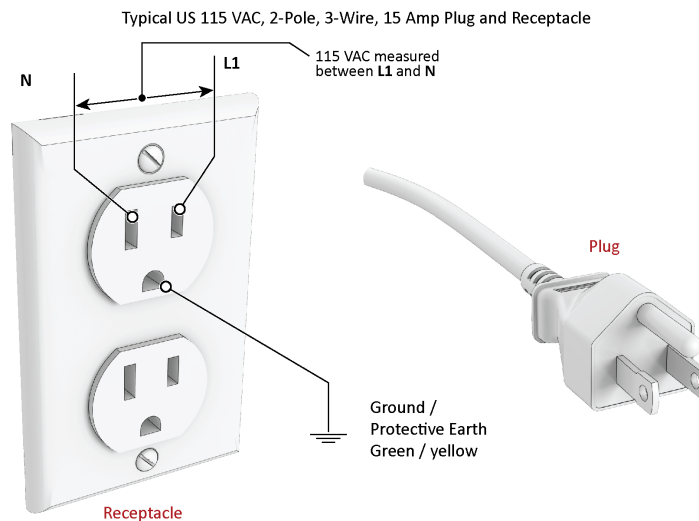
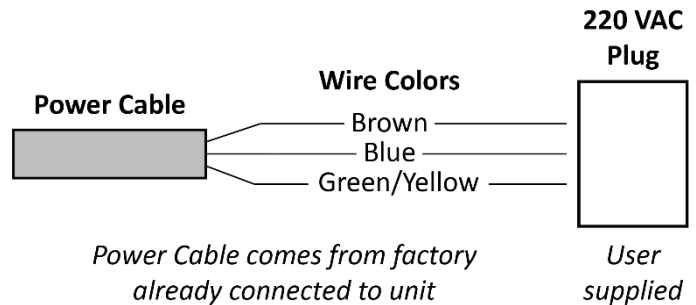

To connect to a 115 VAC power source:

If the AB28 is connected to power, disconnect it. **Do not begin any electrical work until you have verified that power has been disconnected from the unit.**

1. **115 VAC Plug.** The AB28 does not come with a Plug; have a **licensed Electrician** install the appropriately rated 15 VAC NEMA 2 Pole 3-Wire Plug.

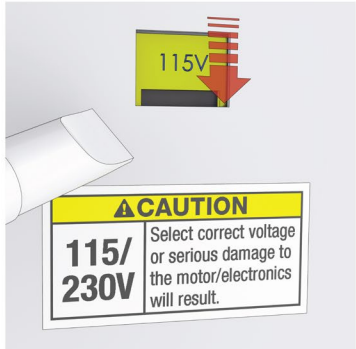

Use finger or screwdriver to slide switch up or down, selecting correct voltage for operation based on plug and final wiring completed by electrician.

The voltage selected will be clearly visible in the switch window once the slider has reached the endstop position for that voltage.

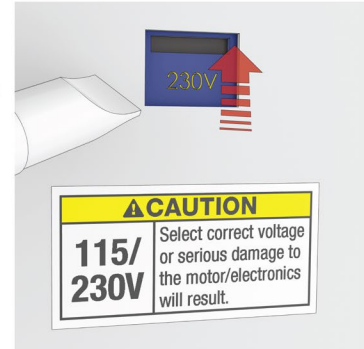

115 VAC Position

230 VAC Position

2. **Voltage Selector Switch.** Verify the Voltage Switch (on the back of the unit, near the ID Label) is set to the **115V** setting, if not then move the switch to the 115V position. This can be accomplished using either your finger or a slot Screwdriver.
3. Double check that Voltage Selector Switch to make sure it is set to the **115V** setting.
4. **Connect** the Plug to an appropriately rated 115 VAC outlet.

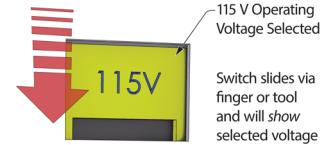

To connect to a 230 VAC power source:

If the AB28 is connected to power, disconnect it. **Do not begin any electrical work until you have verified that power has been disconnected from the unit.**

1. **230 VAC Plug.** The AB28 does not come with a Plug; have a **licensed Electrician** install a 250 VAC NEMA 30A, 2-Pole, 3-Wire plug. **Do not change a 115 VAC plug to a 230 VAC plug unless you are a licensed, certified Electrician.**
2. Change the setting of the Voltage Selector Switch on the back panel of the Tire Changer to **230V**.
This can be done using either your finger or a slot screwdriver.
3. Double check that Voltage Selector Switch to make sure it is set to the **230V** setting.

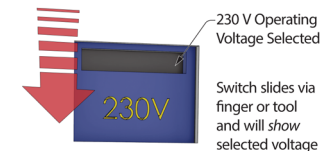

CAUTION The Voltage Selector Switch **must** match the power source. If you plug the unit in to 115 VAC power when the Switch is set to 230V or you plug the unit in to 230 VAC power when the Switch is set to 115V, you void your warranty and you could severely damage the Tire Changer.

4. Plug in the Tire Changer into an appropriately rated 230 VAC outlet.

Additional electrical information:

- **You must ground the Tire Changer.**
- Damage caused by improper electrical installation (such as not grounding the unit) voids the warranty.

DANGER Disconnect power **before** performing **any troubleshooting or maintenance**. Make sure the unit cannot be re-energized until you are done. This equipment has internal arcing or sparking parts that should not be exposed to flammable vapors. The unit must **not** be located in a recessed area or below floor level.

Final Checklist

Make sure the following items have been completed **before** putting the Wheel Balancing Machine into normal operation:

- 1. **Review the Installation Checklist.** Make sure that all of the steps on the **Installation Checklist** have been performed.
- 2. **Test the power source.** Wheel Balancing Machine functions require electrical power. Turn the on-off rocker switch to the on position. If the display panel indicators light, you have power.
- 3. **Check the Anchor Bolts.** If the Wheel Balancing Machine is bolted down, make sure the Anchor Bolts are in position and tight.
- 4. **Leave the Manual with the owner/operator.** Questions are going to come up that only the Manual can answer. Plus, new Operators will need to study it before balancing Wheels. The Manual needs to be kept near the Wheel Balancing Machine at all times.

Operation

This section describes how to use your Wheel Balancing Machine.

It displays and describes the main components and processes involved in mounting a Wheel on the Shaft and balancing it, followed by the necessary procedures for each step in the process.

⚠ DANGER Being in close proximity to a Wheel Balancing Machine is a serious endeavor with potentially life-threatening risks. Only trained, authorized, supervised personnel may be within 30 feet of the Wheel Balancing Machine while it is in use. ***Do not assume you are going to be safe using the Wheel Balancing Machine this time just because nothing happened last time.***

Usage Precautions

Keep the following in mind while you use your Wheel Balancing Machine:

- Make sure all Operators receive specific training in Wheel Balancing **before** they are allowed to use the Wheel Balancing Machine, that their training is verified through a testing program, and that all training is documented. All others, including children and untrained personnel, ***must*** be kept at least 30 ft. (9 m) away from the Wheel Balancing Machine while it is in use.
- Make sure new Operators are trained and supervised in the use of the Wheel Balancing Machine.
- ***Never*** balance ***damaged*** Tires or Wheels.
- When using the Wheel Balancing Machine, protect your hands; there are multiple pinch point dangers on the unit. ***Do not rest your hands on any part of the Wheel Balancing Machine while using it.***
- You ***must*** wear OSHA-approved (publication 3151) Personal Protective Equipment at all times when installing, using, maintaining, or repairing the Wheel Balancing Machine. Leather gloves, steel-toed work boots, eye protection, and back belts ***are mandatory***.
- When using the Wheel Balancing Machine, the operator must wear ***ANSI-approved*** eye protection at all times: safety glasses, a face shield, or protective goggles.

⚠ WARNING Always wear ANSI-approved eye protection. An accident could cause significant injuries to your eyes.

- The Wheel Balancing Machine may operate differently than other Wheel Balancing Machines you have used. APEX recommends that Operators practice on multiple non-customer Wheels to get familiar with how the product works ***before*** starting work on customer Tires.
- Keep the work area clean and well lit. Dirty, cluttered, and dark work areas increase the chances of an accident occurring.
- Do not access the inside of the unit unless instructed to do so by APEX Support.

⚠ WARNING Do not use the Wheel Balancing Machine in a wet environment or expose it to rain or excess moisture.

- If you need to use an extension cord to supply power to the unit, use one with a current rating equal to or greater than that of the Wheel Balancing Machine. Cords rated for less current than the Wheel Balancing Machine could overheat. If used, arrange the extension cord so that it will not be tripped over or pulled out.
- Do not use the Wheel Balancing Machine in the vicinity of open containers of flammable liquids.

- Clean the unit according to the instructions in the **Maintenance** section.
- Read the **entire** *Installation and Operation Manual* **before** using the Wheel Balancing Machine.
- Make a visual inspection of the Wheel Balancing Machine **before each use**. Do not operate the Wheel Balancing Machine if you find an issue. Instead, take it out of service, then contact your dealer, visit APEX.com/support, or call APEX at **(877) 432-6627**.

Front Panel Display and Controls

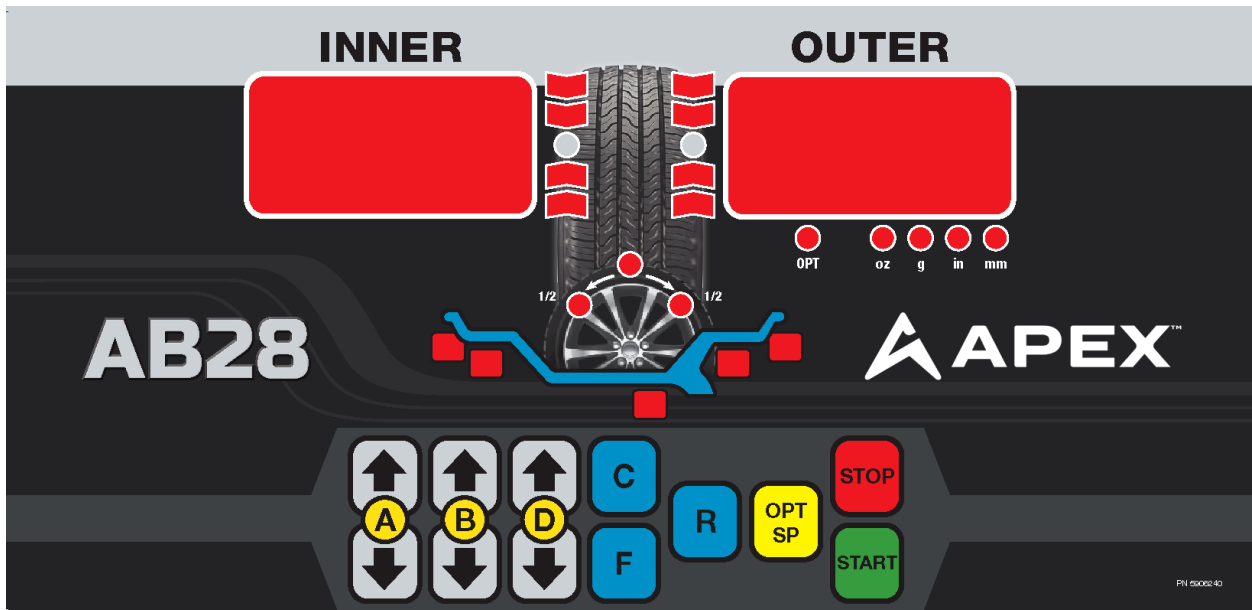

The parts of the Control Panel include:

- **Inner Display Window.** During Measurements—*before* testing the Wheel for balance—this Window indicates which measurement need to be entered. *After* testing the Wheel—it displays the weight that needs to be added to the inner side/plane of the Wheel, if any.

The three measurements to be entered are:

Distance. Indicated by **-A-** on the Inner Window. (May be automatically entered using the inner arm distance arm.)

Width. Indicated by **-B-** on the Inner Window. (Measured using the Wheel Caliper)

Diameter. Indicated by **-D-** on the Inner Window. (May be automatically entered using the inner distance arm.)

- **Outer Display Window.** During measurement, this Window displays the value you are entering. During the testing, it displays the weight to be added to the outer rim/plane of the Wheel.
- **Indicators between Inner and Outer Display Windows.** When Weight(s) needs to be added to the inner rim/plane of a Wheel, as you manually turn the Wheel and watch the indicators to the **right** of the **Inner Display Window**. When all of the indicators are lit, press the Brake to hold the Wheel and then add the specified weight to Top Dead Center (12 o'clock high) on the Wheel.

To add weights to the outer rim/plane of the Wheel, the process is identical, but watch the lights to the **left** of the **Outer Display Window** and slowly rotate the Wheel until all the lights to the left of the Window are lit.

- **System Status Indicators.** Located under the Outer Display Window, these indicate
 - Wheel data value units in MM or In.
 - Balance Weight test results in grams or ounces
 - Motor cover open indicator
 - OPT indicator
 - **Balance Mode Indicators.** These lights indicate the Wheel Plane weight position.
 - **A Key.** Used to manually input A or A1 value. This is the distance between the machine and the Inside Plane of the Wheel. Measured with the inner distance arm.
 - **B Key.** Used to manually input B or B2 value. This is the width of the Wheel. Measured with the Wheel Caliper.
 - **D Key.** Used to manually input the D or D1 value. This is the diameter of the Wheel. Automatically entered using the inner distance arm, or manually read from the tire.
- F Key.** Displays the actual imbalance of the Wheel. Weight values displayed are rounded off by default. Pressing the **F** key displays the actual weight.

For example:



- **R Key.** Selects Balance Mode, DYN, ALU 1 through 5 and STA.
- **C Key** Enters the calibration mode.
- **OPT/SP Key.** Selects Optimizer mode/Split Weight hidden mode.
- **Stop Key.** Stops the current operation.
- **Start Key.** Starts the balance test with the current input data.

Combination Key Functions

Press Keys	Function
F + A	Changes weight display from grams to ounces.
F + B	Changes width display from millimeters to inches.
F + D	Manually inputs the D2 value of the Wheel.
F + STOP	Enters System parameter settings.

Balance Mode Indications

Pushing the **R** key cycles through the available balance measurement modes. There are six dynamic balancing modes and one static balancing mode available. The mode chosen is dependent on the type of Wheel.

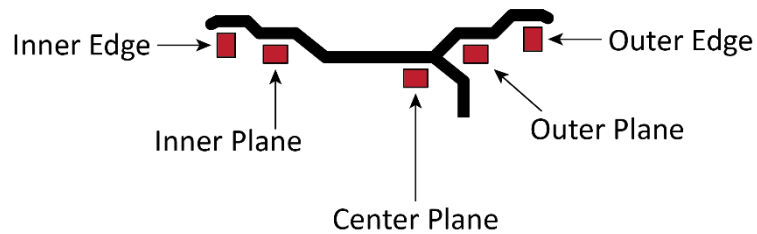

Mounting a Wheel on the Shaft

When you want to balance a Wheel, the first step is to mount it on the Shaft.

Important: All Wheels should be mounted so that the inside (the side of the Wheel that goes closest to the Vehicle) goes on the Shaft first.

Important: Do not hammer on the Quick Nut to tighten. This will damage the Quick Nut, which is not covered under the warranty.

Front- Cone Mount. The preferred method, as it generally produces the most accurate balancing results.

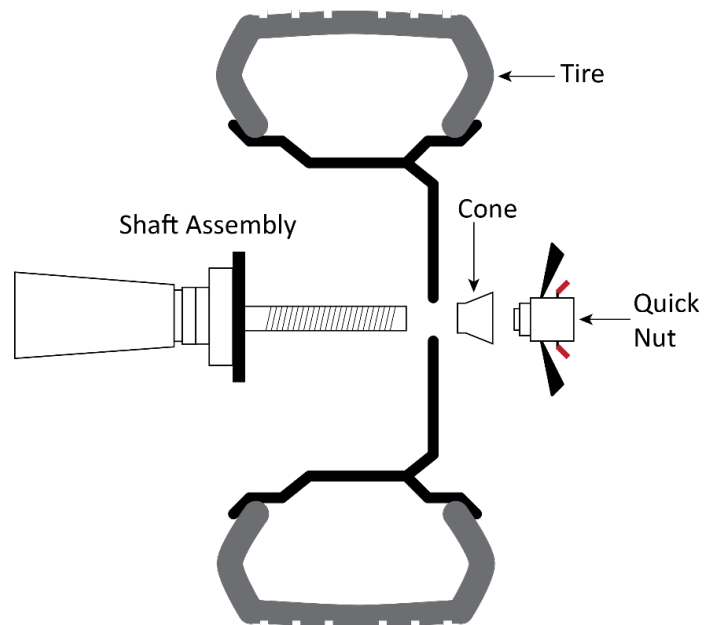

Rear-Cone Mounting.

Use this method if the Wheel cannot be mounted with the Front-Cone Mounting. The spring is placed on the Shaft first, then use an appropriate sized cone, the Wheel, the Quick Nut Cup and the Quick Nut.

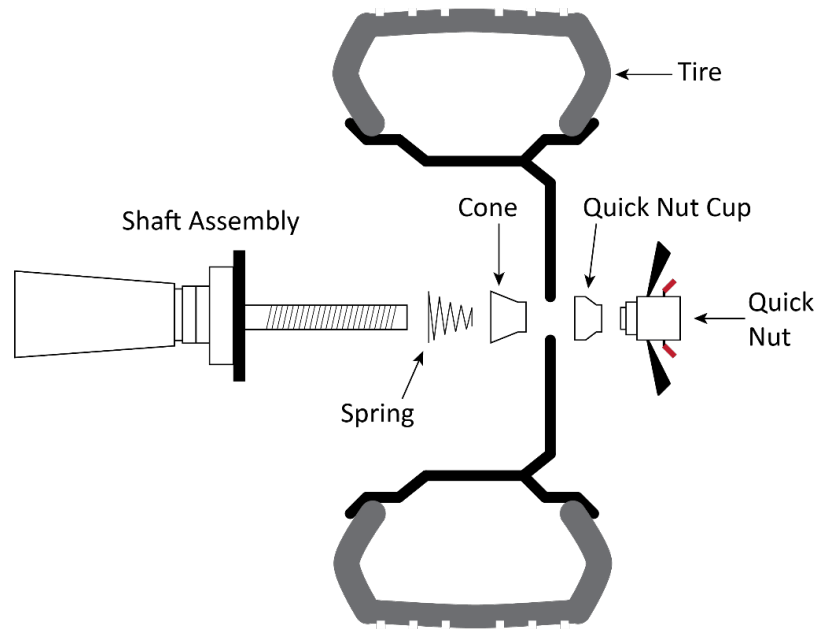

Dual Cone Mounting.

Generally only used for some aftermarket or OEM performance Wheels that have a center hole deep enough to allow the use of two cones on the Shaft.

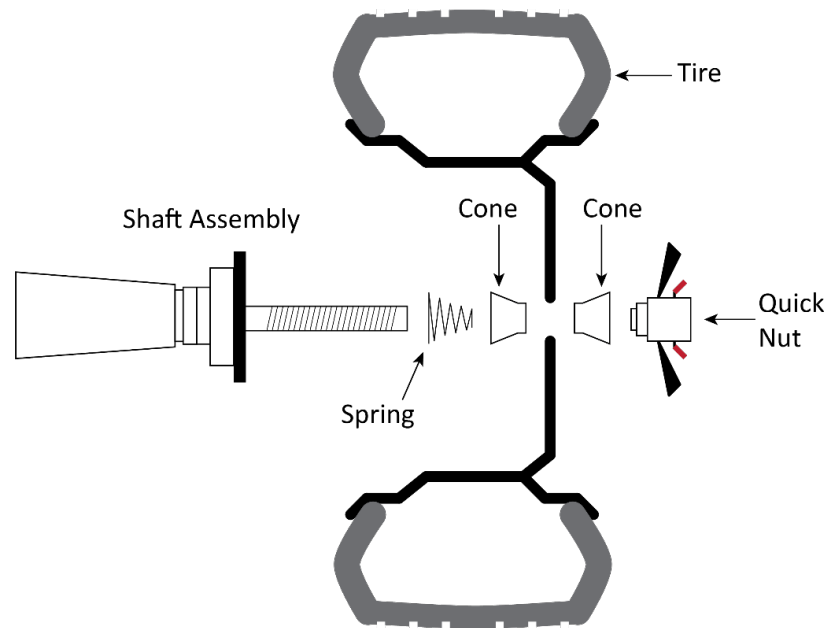

To mount a Wheel:

1. Make sure you are dressed appropriately: leather gloves, steel-toed work boots, back belts, hearing protection, and ANSI-approved eye protection: safety glasses, face shield, or goggles.
2. Determine which mounting method you want to use.
3. Move the Wheel you are going to mount next to the Shaft.
4. Select the Mounting Cone that best fits the center hole on the Wheel.
5. If Rear-Cone or Dual-Cone mounting, install the cone spring and the desired cone onto the Shaft.
6. Clean the Wheel.
7. Remove accumulated dust and provide a clean mounting surface for the Wheel.
8. Remove any weights from previous balancing efforts.
9. Visually inspect the Wheel mounting surface for deformations or damage that would prevent the Wheel from riding on the Shaft correctly.

10. Verify the tire is inflated to the correct pressure.

Note: Avoid damaging the Shaft threads. When loading and unloading Wheels, do not slide the Wheels along the screw threads of the Shaft.

11. Lift the Wheel and put it onto the Shaft, then slide it back towards the Shaft Flange.

You may need to lift the Wheel slightly when positioning a Cone in the center hole of the Wheel.

12. While holding the Wheel and other hardware in place, slide the Quick Nut over the Shaft while holding the red Quick-Release Levers next to the black, larger Wings.

Holding the red Quick-Release Levers next to the Wings lets you quickly slide the Quick Nut into position near the Wheel.

13. Release the Quick-Release Levers.

14. Turn the black Quick Nut Wings to fully tighten the Quick Nut, and secure the Wheel, in place.

You may want to spin the Wheel some as you tighten the Quick Nut; this can help you get a strong, secure fit.

Important: Do not hammer or hit the Quick Nut to tighten it. You will damage the Quick Nut, which is **not** covered under the Warranty.

Wheel Measurements

In order to balance a Wheel, the Balancer **must** know three pieces of information about the Wheel. You can gather these measurements and enter them manually, *or in the case of the Inner Distance and Wheel Diameter*, they may be entered automatically using the Inner Measurement Arm.

The three measurements are:

- **Inner Distance.** The distance from the side of the Balancer to the Inner Edge of the Wheel. Measured by the Inner Distance Arm. To measure and input the value, pull out the Inner Arm and touch it to the Inner Edge of the Wheel, read the value on the Inner Distance Arm, and enter that value using the **+** and **-** buttons above and below the **A** key on the Control Panel. The inner arm is graduated in cm.
- **Width.** The distance from the Inner Edge of the Wheel to the Outer Edge. Determined manually by measuring with the Caliper. To measure and input the value, measure with the Calipers, then enter that value using the **+** and **-** buttons above and below the **B** key on the Control Panel.
- **Diameter.** The diameter of the Wheel. Should be printed on the sidewall of the Tire. Can also be determined automatically using the Inner Measurement Arm. To manually input the value, read the value from the Tire Sidewall or measure with the Calipers, then enter that value using the **+** and **-** buttons above and below the **D** key on the Control Panel.



Tip To automatically enter the A Inner Edge/Plane distance and D the diameter:

1. Mount the Wheel.
2. Turn on the Balancer. The power switch is located on the left-hand side near the front of the cabinet. The display should be flashing.
3. Select the balancing mode. Dynamic, Static, ALU1 through 5.

4. Slowly slide the Inner Measurement Arm out from the side of the Balancer and touch the rim of the Wheel. You will see the inner distance measurement and the Wheel diameter value appear in the Outer Display Window.
5. Return the Inner Measurement Arm to its rest position.

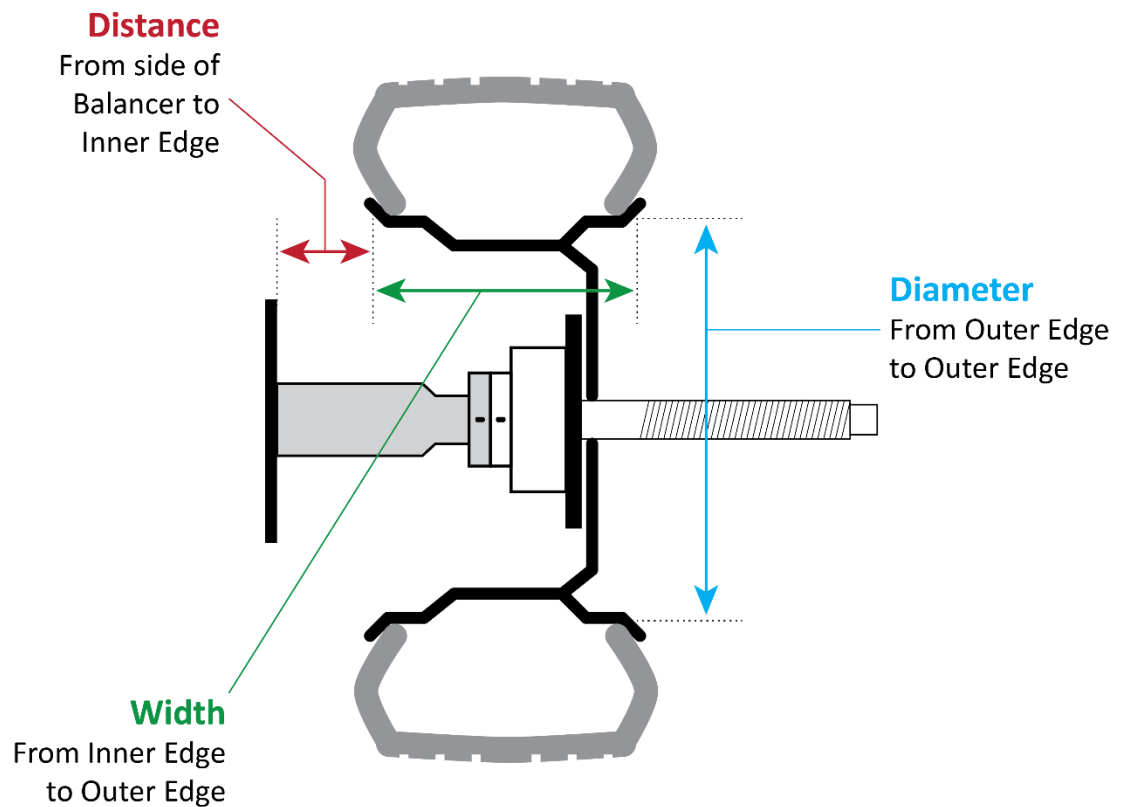

A **-b-** should now be flashing in the Inner Window. Manually determine the width of the tire using the Wheel Caliper, and then enter this value using the **+** and **-** buttons above and below the **B** key on the Control Panel.



Note: If you start balancing a Wheel without entering one or more measurements, the Balancer will use default values for any measurement you did not enter. The Balancer will spin and weight to be added for correction will appear, but without correct measurements it is virtually guaranteed that the balance will **not** be accurate.

Balancing Modes

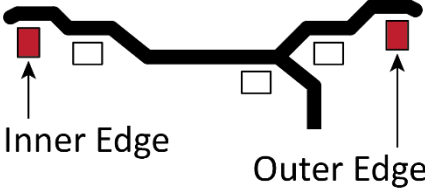
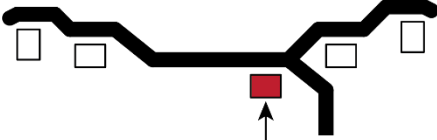
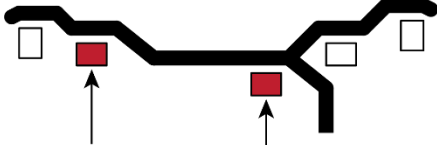
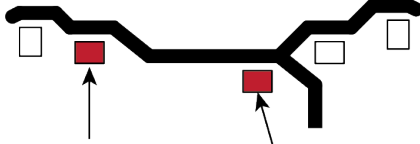
There are three primary balance modes Dynamic, Static and ALUS. Five alternate modes ALU 1 through ALU 5 are also provided and described below.

<p>DYN - The dynamic balance mode clamps balance correction weights on the two outside edges of a steel Wheel. <i>Apply all correction weight(s) at 12 o'clock.</i></p>	 <p>Inner Edge Outer Edge</p>
<p>STA - The static balance mode utilizes adhesive balance correction weights on the Center Plane only. <i>Apply all correction weight(s) at 6 o'clock.</i></p>	 <p>Center Plane</p>
<p>ALUS - this balance mode is the primary balance mode for Aluminum Wheels and utilizes adhesive correction weights on the Inner and Center Plane locations. Wheel Data is entered automatically using the Inner Measuring Arm. <i>Apply correction weights using the Inner Measuring Arm only.</i></p>	 <p>Inner Plane Center Plane</p>
<p>ALU 1 - This balance mode utilizes adhesive correction weights on the Inner Plane and on the Center Plane behind the Wheel spokes. All Wheel data is manually entered. <i>Apply all correction weight(s) at 6 o'clock.</i></p>	 <p>Inner Plane Center Plane</p>
<p>ALU 2 - This balance mode utilizes adhesive correction weights on the Inner Plane and on the Outer Plane of the Wheel. <i>Apply all correction weight(s) at 6 o'clock.</i></p>	 <p>Inner Plane Outer Plane</p>

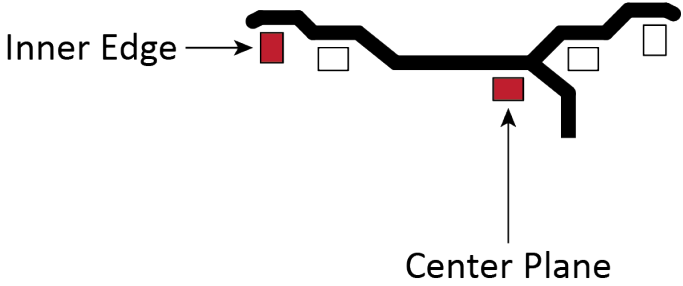
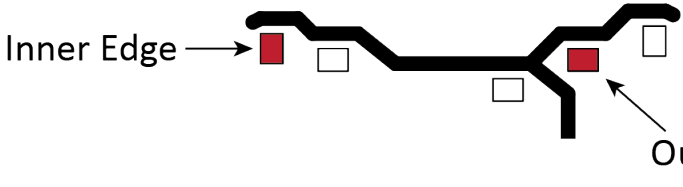
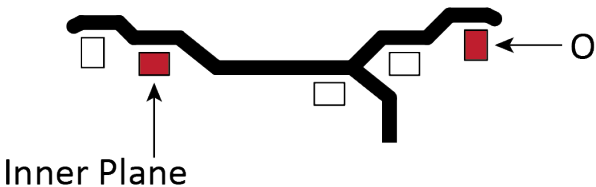
<p>ALU 3 – This balance mode clamps balance correction weights on the Inner Edge at 12 o'clock and utilizes adhesive correction weights at 6 o'clock on the Center Plane.</p>	 <p>Inner Edge →</p> <p>Center Plane</p>
<p>ALU 4 - This balance mode clamps balance correction weights on the Inner Edge at 12 o'clock and utilizes adhesive weights at 6 o'clock on the Outer Plane.</p>	 <p>Inner Edge →</p> <p>Outer Plane</p>
<p>ALU 5 – This balance mode utilizes adhesive balance correction weights on the Inner Plane at 6 o'clock and clamps weights at 12 o'clock on the Outer Edge.</p>	 <p>Inner Plane</p> <p>Outer Edge</p>

Operation in Dynamic Balance Mode

1. Make sure you are dressed appropriately: leather gloves, steel-toed work boots, back belts, hearing protection, and ANSI-approved eye protection: safety glasses, face shield, or goggles.
2. Visually inspect the Balancer to verify everything is in place.
3. The Tire cover should be up and a Tire mounted on the Balancer Shaft. Refer to [Mounting a Wheel](#) for mounting instructions, if required.
4. Turn on the Balancer. The power switch is located on the left-hand side near the front of the cabinet. The display should be flashing, and **-a-** will appear in the Inner Display Window.
5. The Dynamic Balance Mode is **automatically selected** on powering up the Balancer. You may also access different balancing modes by pressing **R** until the **DYNAMIC weight position** is displayed as shown here.

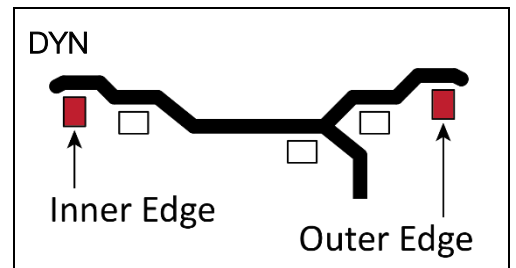

- Input the Wheel parameters. Slide the inner distance arm to touch the Inner Edge of the Wheel rim and hold in place. The Balancer will beep and enter the side distance and Wheel diameter automatically into the Balancer's memory. The value should appear in the Outer Display Window. Alternatively, you may read this value off the inner measuring arm and enter it manually using the **A** and **D** key.

- Slide the Inner Measurement Arm back to its rest position inside the Balancer.

Note: If the values appear incorrect you can turn off the power to reset the machine and start the process over.

- Determine the width of the Wheel using the Wheel Caliper and input this value using the front panel button labelled **B**. **Enter the Wheel width in inches.** The value should appear in the Outer Window.

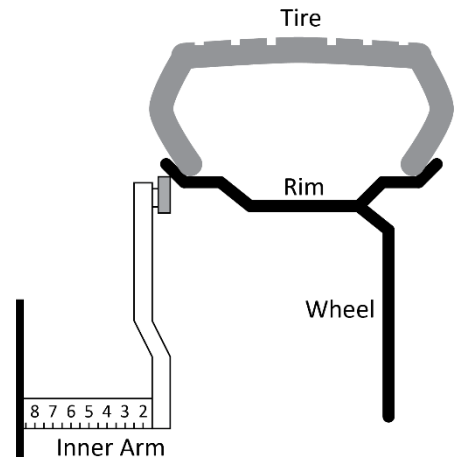

- Verify all three measurements.

- Press the **Start** Button. The Balancer will rotate and test the Wheel for balance.

⚠ WARNING Stay clear and do not touch the Wheel or the Tire while it is rotating.

- The front panel display will show the unbalanced weight correction values for both the inner and outer Wheel Planes. These values are rounded to the nearest .25 oz. Press **F** to view the actual unbalanced weight without rounding. If both windows displays **0.0** no corrective weights are required on that plane.
- The Wheel will automatically stop or you may depress the brake with your foot to stop the Wheel.
- Note the values displayed in the inner and outer display windows. These amounts are the weights required to correct the inner and outer imbalance. Locate and prepare the correct weight quantities.
- Release the brake and slowly rotate the Wheel manually. Note the Indicator lights to the **right** of the **Inner Display Window**. When all the lights are lit, the Balancer will sound three beeps and the Wheel has reached the position to attach the inner correction weight(s). Hold the Wheel in place using the brake and clamp the weight(s) at the **12 o'clock position** on the inside Wheel rim. Clamp the weights using the Wheel Weight Tool.
- Manually rotate the Wheel slowly again until the lights to the **left** of the **Outer Display Window** are all lit and three beeps are given by the Balancer. Hold the Wheel in place using the brake and clamp the corrective weight(s) to the outside rim at the **12 o'clock position**. Clamp the weights using the Wheel Weight Tool.
- Press the **Start** Button to spin and test the Wheel again.

The Wheel is balanced when both the Inner and Outer Windows show **0.0**.

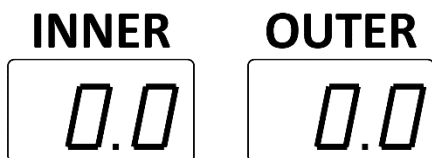

It may take more than one attempt to get the balance to **0.0 | 0.0**.

Operation in Static Balance Mode

Static balancing is for older Wheels under 4 inches wide and Motorcycle Wheels. Adhesive Weights are only placed on the Wheel's Center Plane in static balancing.

1. Make sure you are dressed appropriately: leather gloves, steel-toed work boots, back belts, hearing protection, and ANSI-approved eye protection: safety glasses, face shield, or goggles.
 2. Visually inspect the Balancer to verify everything is in place.
 3. Wheel and tire firmly mounted on the Balancer Shaft.
 4. Refer to **Mounting a Wheel** for mounting instructions, if required.
 5. Turn on the Balancer. The power switch is located on the left-hand side near the front of the cabinet. The display should be flashing, and **-a-** will appear in the Inner Display Window.
 6. Select the balance mode based on the Wheel.
 7. Press **R** until the **STA** Mode is displayed as shown here.
 8. Input the Wheel parameters. Slide the inner distance arm to touch the Center Plane of the Wheel rim and hold in place. Read the distance off the Inner Distance Arm and enter into the Balancer using the **A** key. Enter the Wheel diameter using the **D** key and the Wheel width using the **B** key.
 9. Return the Inner Measurement Arm to its rest position on the side of the Balancer.
 10. Determine the width of the Wheel using the Wheel Caliper and input this value using the front panel button labelled **B**. The value should appear in the Outer Window.
- Note:** If the values appear incorrect you can turn off the power to reset the machine and start the process over.
11. When all three measurements are correct, press the **Start** Button. The Balancer will rotate and test the Wheel for balance.

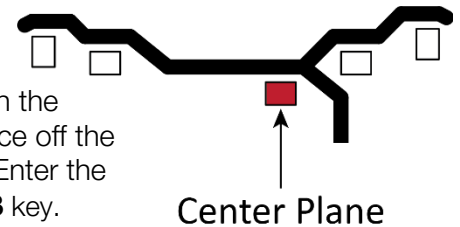

- ⚠ WARNING** Stay clear and do not touch the Wheel or the Tire while it is rotating.
12. The front panel display will show the unbalanced weight correction values for the center Wheel Plane. These values are rounded to the nearest .25 oz. If both windows display **0.0** no corrective weights are required on that plane.
 13. The Wheel will automatically stop or you may depress the brake with your foot to stop the Wheel.
 14. Note the value displayed in the display windows. This is the weight(s) required to correct the Wheel imbalance. Locate and prepare the correct weight quantities.
 15. Release the brake and slowly rotate the Wheel manually. Note the Indicator lights to the **right** of the **Inner Display Window**. When all the indicators are lit and the Balancer sounds three beeps, the Wheel has reached the position to attach the adhesive correction weight(s) on the Central Plane. Hold the Wheel in place using the brake and apply the weight(s) at the **6 o'clock position** on the Center Plane of the Wheel. If multiple weights are required, center at 6 o'clock.
 16. Press the **Start** Button to spin and test the Wheel again. The Wheel is balanced when the Display Windows show **0.0**.

It may take more than one attempt adding weights to get to **0.0 | 0.0**.

Aluminum Alloy Balancing Modes

The primary balancing mode for Aluminum Wheels is **ALUS**. This mode uses the Inner Measurement Arm to automatically measure and enter Wheel data. The Inner Measurement Arm is also used to place the weights in the correct position(s).

ALU1 through **5** are alternate balancing modes that require manual Wheel data entry.

IMPORTANT Clip-on Weights are placed at the **12 o'clock position** on the Wheel when all the Wheel indicator lights are illuminated in ALU-3 (Inner Edge), ALU-4 (Outer Plane), and ALU-5 (Outer Edge).

IMPORTANT Adhesive weights are placed at the **6 o'clock position** on the Wheel when all the Wheel indicator lights are illuminated in ALU-1, ALU-2, ALU 3 (Center Plane) ALU-4 (Inner Edge), and ALU-5 (Inner Plane).

IMPORTANT In ALUS and the Split Weight function mode only, Weights are placed on the Wheel using the **Inner Distance Arm** when all the indicator lights are illuminated. Do **not** place at the 12 o'clock position.

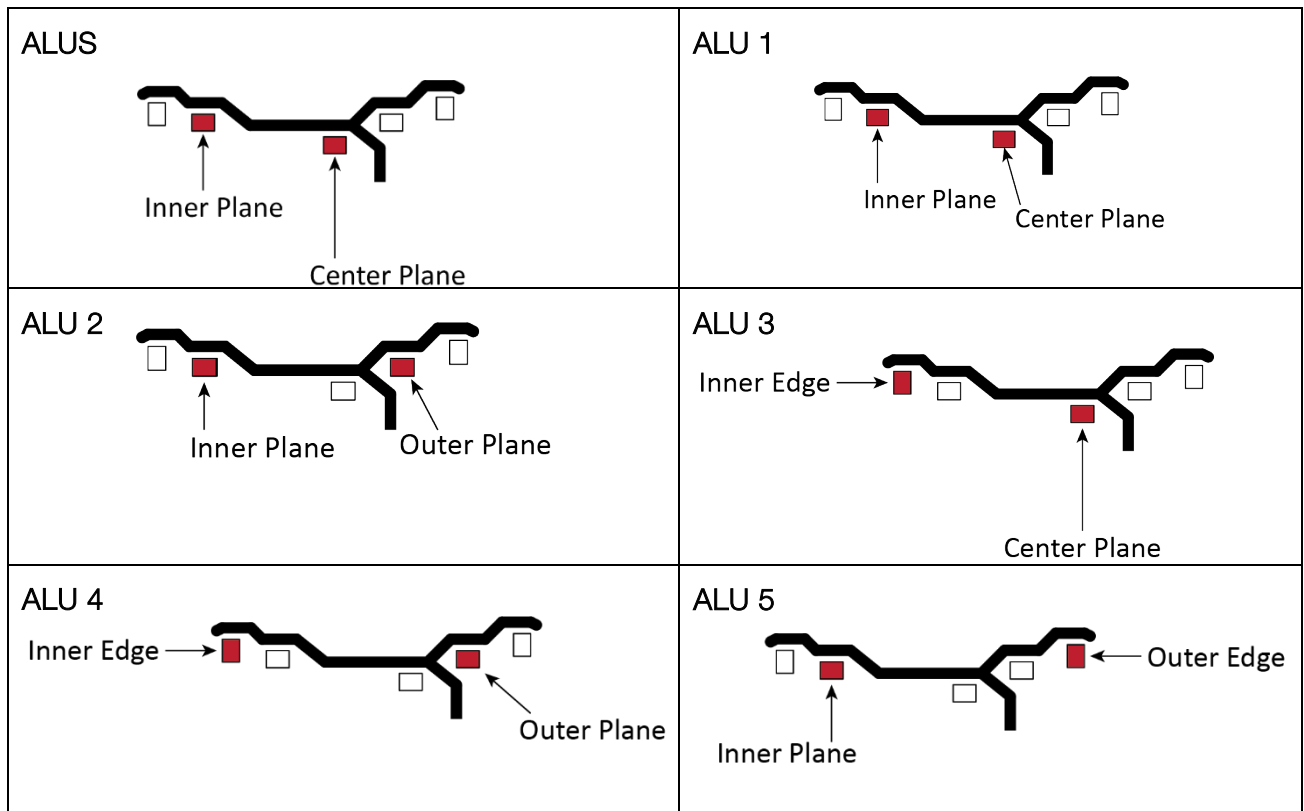

To balance a Wheel in the ALUS Mode:

Important: When using Adhesive Weights, it is extremely important to remove any pre-existing weights and to **clean the Wheel**, use alcohol or similar to remove oils, dirt and adhesive residue.

- Make sure you are dressed appropriately: leather gloves, steel-toed work boots, back belts, hearing protection, and ANSI-approved eye protection: safety glasses, face shield, or goggles.
If you find any issues, fix them. If there are issues you cannot fix, refer to [Troubleshooting](#).
- Visually inspect the Balancer to verify everything is in place. The Wheel and tire should be firmly mounted on the shaft.

- c. Make sure the Wheel you want to balance is both clean and free of any weights that may have been put on previously. If it is dirty, clean it. Remove any existing weights.

Important: If the values appear incorrect, you can turn off the power to reset the machine and start the process over.

- d. Mount the Wheel on the Balancer.

Refer to **Mounting a Wheel** for mounting instructions, if needed.

- e. Turn the Balancer Off and then back On, to reset, if required. The display should be flashing, and **—a—** will appear in the Inner Display Window.

- f. On the Control Panel, press the **R** button until the **ALUS** Indication is lit.

- g. Pull out the Inner Measurement Arm and hold against the Inner Plane measuring the distance and diameter **a1 d1** until the Balancer beeps and then move the Inner measurement Arm to the Center Plane measuring **a2 d2** until the Balancer beeps again.

Note: *Do not return the Inner Measurement Arm to the side of the Balancer between measurements.*

Note: If the values appear incorrect you can turn off the power to reset the machine to start the process over. Slide the Inner Measurement Arm back to its rest position inside the Balancer.

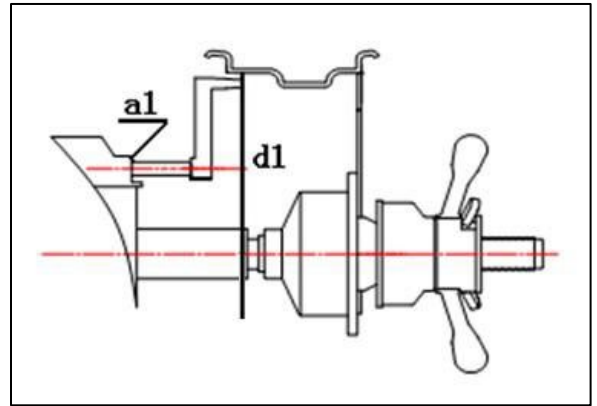

- h. Press the **Start** Button. The Wheel spins briefly.

- i. When the balance values appear in both windows, the Wheel will stop automatically or you may use your foot on the brake to stop the Wheel.

- j. Check the value on the Inner Window.

- If the value is **00**, you no correction weight is required on the Inner Plane.
- If there is a value—**.25**, for example—you need to add that amount of Weight to the Inner Plane.

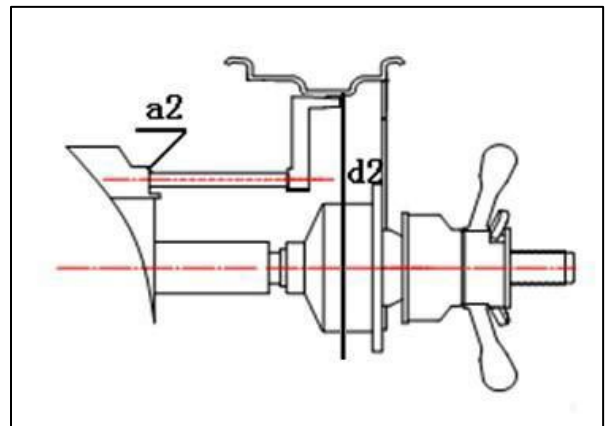

- k. To add Weight, break off the appropriate number of Adhesive Weight sections.

- l. Manually turn the Wheel, watching the indicators to the right of the Inner Window.

- m. The Indicators light up or go out as you move the Wheel. When all of the Indicators light, press the Brake Pedal to hold the Wheel at that position. The Wheel will stop automatically or you may use your foot on the brake pedal to stop the Wheel.

- n. Pull the backing off the Adhesive Weights, then center the Weight(s) on the end of the Inner Distance Arm and add the Weight on the Inner Plane **a1 d1** position on the Wheel. As you pull out the inner arm, the display will count down, reach 0 then beep at the correct location to place the weight(s). Press the weights firmly onto the Wheel and return the inner arm to its rest position.

If you are adding Adhesive Weight with multiple sections, center them on the end of the **Inner Distance Arm**.

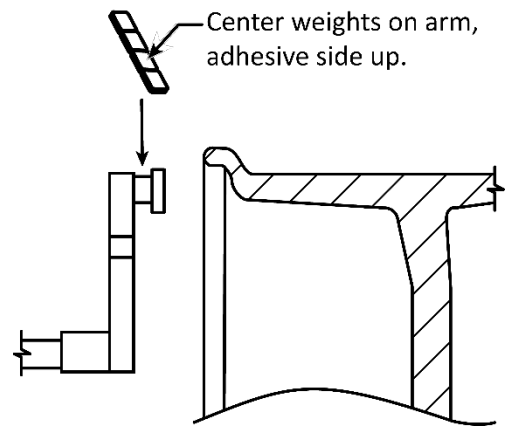

- o. Check the value on the Outer Window:
- If the value is **00**, no correction Weight is required on the Center Plane.
 - If there is a value—**.25**, for example—you need to add that amount of Weight to the Center Plane.
- p. To add Weight, break off the appropriate number of Adhesive Weight sections.
- q. Manually turn the Wheel, watching the indicators to the left of the outer window. The Indicators light up or go out as you move the Wheel.
- r. When all of the Indicators are lit, press the Brake Pedal to hold the Wheel at that position.
- s. Pull the backing off the Adhesive Weights, then center the weight(s) on the end of the inner distance arm and add the Weight on the Inner Plane **a2 d2** position on the Center Plane of the Wheel. As you pull out the inner arm, the display will count down, reach 0 and beep at the correct location to place the weight(s). Press the firmly onto the Wheel.

If you are adding Adhesive Weight with multiple sections, center them on the Inner Distance Arm then apply them to the Wheel.

- t. Release the Brake Pedal.
- u. Press the **Start** Button to spin the Wheel again.
- v. The Wheel is balanced when both the Inner and Outer Windows show **0.0**.

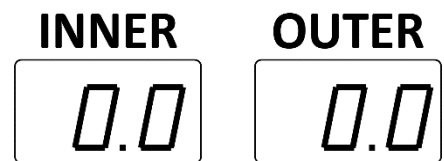

It may take more than one attempt at adding weight(s) to get to **0.0 | 0.0**.

To balance a Wheel using ALU1 Mode:

- a. On the Control Panel, press the **R** button until the **ALU 1** Indication is lit.

Note: ALU 1 requires manually measuring to input the Inner Plane distance, the Wheel Diameter in inches, and the Wheel Width in cm. Refer to the figures below.

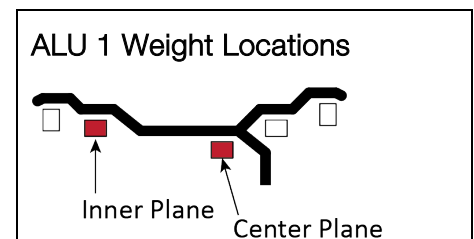

- b. Input the **Inner Plane** Wheel parameter. Slide the Inner Distance arm to touch the Wheel's Inner Plane and hold. Read the distance in cm on the Inner Arm. Enter this value manually using the **A** key. Return the Inner Measuring Arm to the side of the Balancer.

Manually measure and input the **Wheel Width** using the Caliper. Enter this value using the **B** key.

Manually measure the **Wheel Diameter** in inches or read the diameter off the side of the tire, then enter using the **D** key.

Note: If the values appear incorrect you can turn off the power to reset the machine and start the process over.

- c. When all three measurements are correct, press the **Start** Button; the Wheel spins briefly.

WARNING Stay clear and do not touch the Wheel or the Tire while it is rotating.

- d. The Balancer will rotate and test the Wheel for balance. The Balancer will automatically stop, or you may use the foot brake to stop the rotation.
- e. The front panel display will show the unbalanced weight correction values for both the Inner and Center Wheel Planes in **ALU 1**. These values are rounded to the nearest .25 oz. Press **F** to view the actual unbalanced weight without rounding. If either window displays **0.0** no corrective weights are required on that plane.
- f. Check the value on the Inner Window.
- If the value is **00**, do not add weight to the Inner Plane.
 - If there is a value—**.25**, for example—you need to add that amount of Weight to the Inner Plane.
- g. To add Weight, break off the appropriate number of Adhesive Weight sections.
- h. Turn the Wheel, watching the indicators to the **right** of the **Inner Display Window**. The Indicators light up or go out as you move the Wheel.
- i. When all of the Indicators are lit, press the Brake Pedal to hold the Wheel at that position.
- j. Pull the backing off the Adhesive Weights, and add the Weight on the Inner Plane of the Wheel at the **6 o'clock position**. Press the firmly onto the Wheel.

IMPORTANT Do not touch the adhesive portion of the weights. Oils from your skin or on gloves can reduce the holding power of the adhesive.

- k. Check the value on the **Outer Display Window**
- l. If the value is **00**, you do not need to add Weight to the Center Plane.
- m. If there is a value—**.25**, for example—you need to add that amount of Weight to the Center Plane for **ALU 1**.

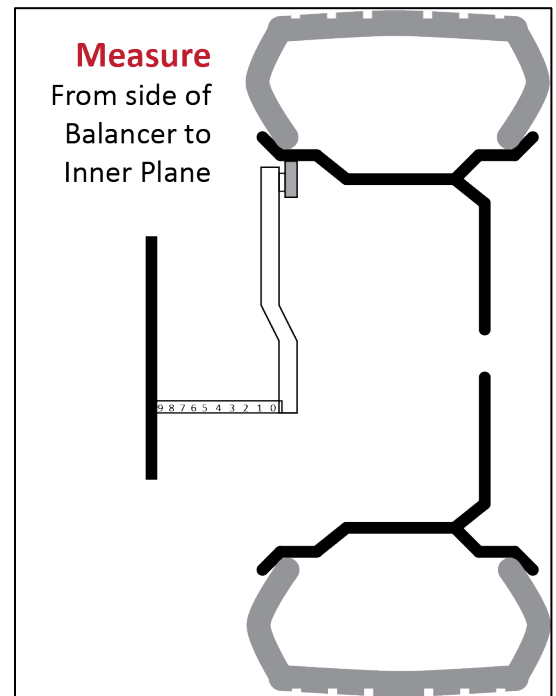

- n. To add Weight, break off the appropriate number of Adhesive Weight sections.
- o. Manually turn the Wheel, watching the indicators to the **left** of the **Outer Display Window**. The Indicators light up or go out as you move the Wheel.
- p. When all of the Indicators are lit and the Balancer sounds 3 beeps, press the Brake Pedal to hold the Wheel at that position.
- q. Pull the backing off the Adhesive Weights and add the Weight on the Center Plane of the Wheel at the **6 o'clock position**. Press the weights firmly onto the Wheel.
- r. Release the Brake Pedal.
- s. Press the **Start** Button to spin the Wheel again.

The Wheel is balanced when both the Inner and Outer Windows show **00**.

It may take more than one attempt at adding weights to get to **0.0 | 0.0**.

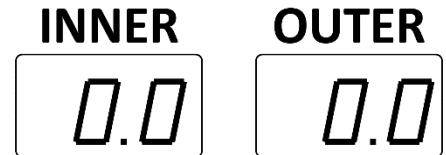

To balance a Wheel using ALU 2 Mode:

- a. Make sure you are dressed appropriately: leather gloves, steel-toed work boots, back belts, hearing protection, and ANSI-approved eye protection: safety glasses, face shield, or goggles.
- b. Visually inspect the Balancer to make sure everything is in place.

If you find any issues, fix them. If there are issues you cannot fix, refer to **Troubleshooting**.

- c. Make sure the Wheel you want to balance is both clean and free of any previously installed weights. If it is dirty, clean it.

Important: When using Adhesive Weights, it is extremely important to **clean the Wheel**. Use alcohol to remove dirt, oil and old adhesive.

- d. Mount the Wheel on the Balancer.

Refer to **Mounting a Wheel** for mounting instructions, if required.

- e. Turn the Balancer Off and then back On, to reset, if required. The display should be flashing, and **-a-** will appear in the Inner Display Window. On the Control Panel, press the **R** button until the **ALU 2** Indication is lit.

Note: **ALU 2** requires manually measuring to input the **Inner Plane** distance in cm, the **Wheel Diameter** in inches, and the **Wheel Width** in cm. Refer to the figures below.

- f. Input the **Inner Plane** Wheel parameter. Slide the Inner Distance Arm to touch the Wheel's Inner Plane and hold. Read the distance in cm on the inner arm. Enter this value in cm manually using the **A** key. Return the Inner Measuring Arm to the side of the Balancer.

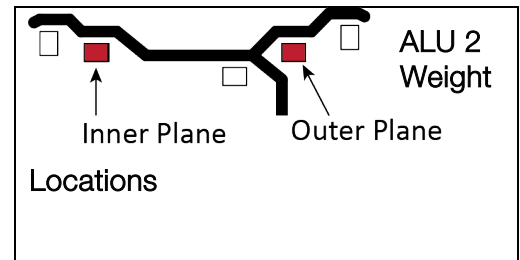

Manually measure and input the **Wheel Width** in cm using the Caliper. Enter this value using the **B** key.

Manually measure the **Wheel Diameter** in inches or read the diameter off the side of the tire, then enter using the **D** key.

Note: If the values appear incorrect you can turn off the power to reset the machine and start the process over.

- g. When all three measurements are correct, press the **Start** Button; the Wheel spins briefly.

WARNING Stay clear and do not touch the Wheel or the Tire while it is rotating.

- h. Press the **Start** Button on the control panel.
- i. The front panel display will show the unbalanced weight correction values for both the inner and outer Wheel Planes. These values are rounded to the nearest .25 oz. Press **F** to view the actual unbalanced weight without rounding. If either window displays **0.0** no corrective weights are required on that plane.

- j. Check the value on the Inner Window.
- If the value is **00**, you do not need to add weight to the Inner Plane.
 - If there is a value—**.25**, for example—you need to add that amount of Weight to the Inner Plane.

- k. To add Weight, break off the appropriate number of Adhesive Weight sections.

- l. Manually turn the Wheel, watching the indicators to the **right** of the **Inner Display Window**. The Indicators light up or go out as you move the Wheel.

- m. When all of the Indicators are lit and the Balancer beeps three times, press the Brake Pedal to hold the Wheel at that position.

- n. Pull the backing off the Adhesive Weights, then add the Weight to the Wheel at **6 o'clock** on the Inner Plane. If you are adding Adhesive Weight with multiple sections, center them at **6 o'clock**.

IMPORTANT Do not touch the adhesive portion of the weights. Oils from your skin or on gloves can reduce the holding power of the adhesive.

- o. Check the value on the Outer Display Window:
- If the value is **00**, you do not need to add Weight to the **Outer Plane**.
 - If there is a value—**.25**, for example—you need to add that amount of Weight to the **Outer Plane** for **ALU 2**).

- p. To add Weight, break off the appropriate number of Adhesive Weight sections.

- q. Manually turn the Wheel, watching the indicators to the **left** of the **Outer Display Window**. The Indicators light up or go out as you move the Wheel.

- r. When all of the Indicators are lit and the Balancer sounds three beeps, press the Brake Pedal to hold the Wheel at that position.

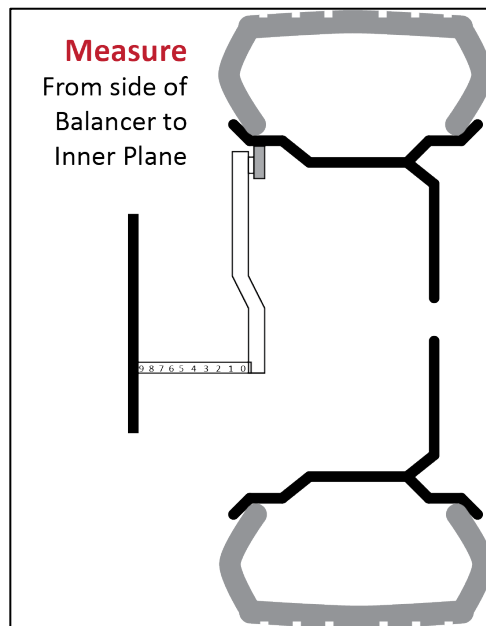

- s. Pull the backing off the Adhesive Weights, then add the Weight to the Wheel at **6 o'clock** on the Outer Plane for **ALU2**. If you are adding Adhesive Weight with multiple sections, center them at **6 o'clock**.
- t. Release the Brake Pedal.
- u. Press the **Start** Button to spin the Wheel again.

The Wheel is balanced when both the Inner and Outer Windows show **0.0**.

It may take more than one attempt at adding weights to get to **0.0 | 0.0**.

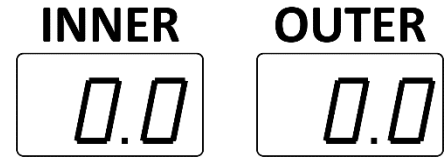

To balance a Wheel using ALU 3 Mode:

- a. Make sure you are dressed appropriately: leather gloves, steel-toed work boots, back belts, hearing protection, and ANSI-approved eye protection: safety glasses, face shield, or goggles.
- b. Visually inspect the Balancer to make sure everything is in place.

If you find any issues, fix them. If there are issues you cannot fix, refer to **Troubleshooting**.

- c. Make sure the Wheel you want to balance is both clean and free of any weights that may have been put on previously. If it is dirty, clean it. Remove any existing weights.

Important: When using Adhesive Weights, it is extremely important to clean the Wheel; use alcohol or similar to remove oils, dirt and adhesive residue.

- d. Mount the Wheel on the Balancer.

Refer to **Mounting a Wheel** for mounting instructions, if needed.

- e. Turn the Balancer Off and then back On, to reset, if required. The display should be flashing, and an **-a-** will appear in the Inner Display Window.

- f. On the Control Panel, press the **R** button until the **ALU 3** Indication is lit.

Important: When using Adhesive Weights, it is extremely important to **clean the Wheel**. Use alcohol to remove dirt, oil and old adhesive.

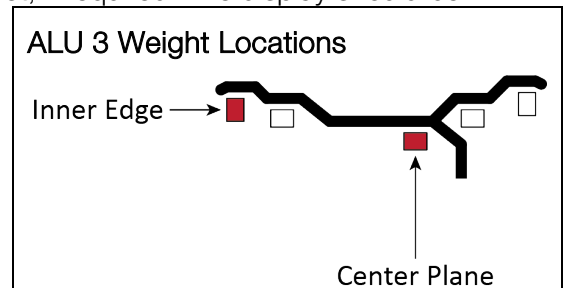

- g. Turn the Balancer Off and then back On, to reset, if required. The display should be flashing, and **-a-** will appear in the Inner Display Window. On the Control Panel, press the **R** button until the **ALU 3** Indication is lit.

Note: **ALU 3** requires manually measuring to input the **Inner Plane** distance in cm, the **Wheel Diameter** in inches, and the **Wheel Width** in cm. Refer to the figures below.

- h. Input the **Inner edge** Wheel parameter. Slide the Inner Distance Arm to touch the Wheel's **Inner Edge** and hold it there. Read the distance in cm on the inner arm. Enter this value manually using the **A** key. Return the Inner Measuring Arm to the side of the Balancer.

Manually measure and input the **Wheel Width** in cm using the Caliper. Enter this value using the **B** key.

Manually measure the **Wheel Diameter** in inches or read the diameter off the side of the tire, then enter using the **D** key.

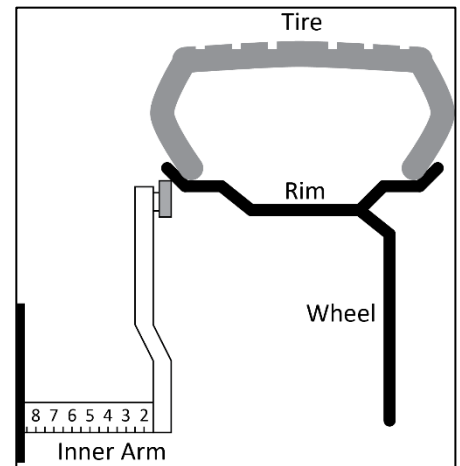

Note: If the values appear incorrect you can turn off the power to reset the machine and start the process over.

- i. When all three measurements are correct, press the **Start** Button; the Wheel spins briefly and will automatically stop or you may use the foot brake to stop the Wheel.

WARNING Stay clear and do not touch the Wheel or the Tire while it is rotating.

Press the **Start** Button on the control panel.

The front panel display will show the unbalanced weight correction values for both the inner and outer Wheel Planes. These values are rounded to the nearest .25 oz. Press **F** to view the actual unbalanced weight without rounding. If either window displays **0.0** no corrective weights are required on that plane.

- j. Check the value on the Inner Window.
- If the value is **00**, you do not need to add weight to the Inner Edge.
 - If there is a value—**.25**, for example—you need to add that amount of Weight to the Inner edge.
- k. Turn the Wheel, watching the indicators to the **right** of the **Inner Display Window**. The Indicators light up or go out as you move the Wheel.
- l. When all of the Indicators are lit and the Balancer sounds three beeps, press the Brake Pedal to hold the Wheel at that position.
- m. Clip the required weight correction to the Inner Edge of the Wheel at **12 o'clock high**.
- n. Check the value on the Outer Display Window:
- If the value is **0.0**, you do not need to add Weight to the Center Plane.
 - If there is a value—**.25**, for example—you need to add that amount of Weight to the Center Plane for **ALU 3**).
- o. To add Weight, manually turn the Wheel, watching the indicators to the **left** of the **Outer Display Window**. The Indicators light up or go out as you move the Wheel.
- p. When all of the Indicators are lit and the Balancer sounds three beeps, press the Brake Pedal to hold the Wheel at that position.

- q. Pull the backing off the Adhesive Weights, then center the weight(s) at **6 o'clock** on the Center Plane of the Wheel and press firmly.

IMPORTANT Do not touch the adhesive portion of the weights. Oils from your skin or on gloves can reduce the holding power of the adhesive.

- r. Release the Brake Pedal.
- s. Press the **Start** Button to spin the Wheel again.

The Wheel is balanced when both the Inner and Outer Windows show **0.0**.

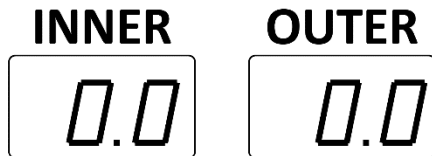

It may take more than one attempt at adding weights to get to **0.0 | 0.0**.

To balance a Wheel using ALU 4 Mode:

- a. Make sure you are dressed appropriately: leather gloves, steel-toed work boots, back belts, hearing protection, and ANSI-approved eye protection: safety glasses, face shield, or goggles.
- b. Visually inspect the Balancer to make sure everything is in place.

If you find any issues, fix them. If there are issues you cannot fix, refer to [Troubleshooting](#).

- c. Make sure the Wheel you want to balance is both clean and free of any weights that may have been put on previously. If it is dirty, clean it. Remove any existing weights.

Important: When using Adhesive Weights, it is extremely important to clean the Wheel; use alcohol or similar to remove oils, dirt and adhesive residue.

- d. Mount the Wheel on the Balancer.

Refer to [Mounting a Wheel](#) for mounting instructions, if needed.

- e. Turn the Balancer Off and then back On, to reset it, if required. The display should be flashing, and **-a-** will appear in the Inner Display Window.

- f. On the Control Panel, press the **R** button until the **ALU 4** Indication is lit.

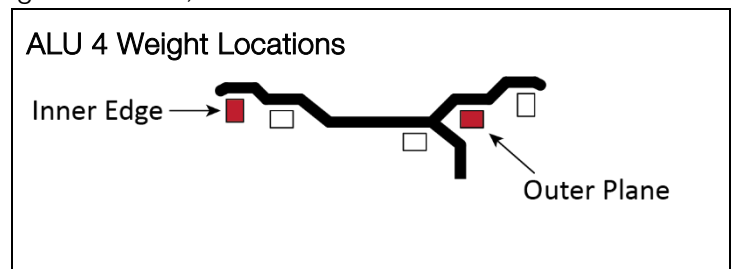

Note: **ALU 4** requires manually measuring to input the **Inner Edge** distance in cm, the **Wheel Diameter** in inches, and the **Wheel Width** in cm. Refer to the figures below.

- g. Input the **Inner Edge** Wheel parameter. Slide the inner distance arm to touch the Wheel's **Inner Edge** and hold. Read the distance in cm on the inner arm. Enter this value manually using the **A** key. Return the Inner Measuring Arm to the side of the Balancer.

Manually measure and input the **Wheel Width** in inches using the Caliper. Enter this value using the **B** key.

Manually measure the **Wheel Diameter** in inches or read the diameter off the side of the tire, then enter using the **D** key.

Note: If the values appear incorrect you can turn off the power to reset the machine and start the process over.

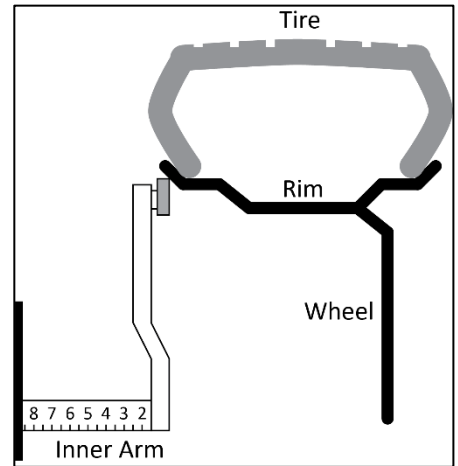

- h. Press the **Start** Button; the Wheel spins briefly.

WARNING Stay clear and do not touch the Wheel or the tire while it is rotating.

- i. Press the **Start** Button on the control panel.
- j. The front panel display will show the unbalanced weight correction values for both the Inner Edge and Outer Wheel Planes. These values are rounded to the nearest .25 oz. Press **F** to view the actual unbalanced weight without rounding. If either window displays **0.0** no corrective weights are required on that plane.
- k. Check the value on the Inner Window.
- If the value is **00**, you do not need to add weight to the Inner Edge.
 - If there is a value—**.25**, for example—you need to add that amount of Weight to the Inner Edge.
- l. To add Weight, turn the Wheel, watching the indicators to the **right** of the **Inner Display Window**. The Indicators light up or go out as you move the Wheel.
- m. When all of the Indicators are lit and the Balancer sounds three beeps, press the Brake Pedal to hold the Wheel at that position.
- n. Clip the Weight(s) at **Top Dead Center** on the Wheel **12 o'clock high** on the Inner Edge.
- o. Check the value on the Outer Display Window:
- If the value is **0.0**, you do not need to add Weight to the Outer Plane.
 - If there is a value—**.25**, for example—you need to add that amount of Weight to the Outer Plane for **ALU 4**).
- p. To add Weight, break off the appropriate number of Adhesive Weight sections.
- q. Manually turn the Wheel, watching the indicators to the **left** of the **Outer Display Window**. The Indicators light up or go out as you move the Wheel.
- r. When all of the Indicators are lit and the Balancer sounds three beeps, press the Brake Pedal to hold the Wheel at that position.
- s. Pull the backing off the Adhesive Weights, then add the correction Weight on the Wheel at **6 o'clock** on the Outer Plane for ALU4. If you are adding Adhesive Weight with multiple sections, center them at 6 o'clock.

IMPORTANT Do not touch the adhesive portion of the weights. Oils from your skin or on gloves can reduce the holding power of the adhesive.

- t. Release the Brake Pedal.
- u. Press the **Start** Button to spin the Wheel again.

The Wheel is balanced when both the Inner and Outer Windows show **00**.

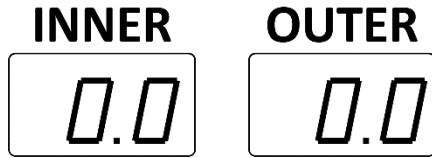

It may take more than one attempt at adding weights to get to **0.0 | 0.0**.

To balance a Wheel using ALU5 Mode:

- a. Make sure you are dressed appropriately: leather gloves, steel-toed work boots, back belts, hearing protection, and ANSI-approved eye protection: safety glasses, face shield, or goggles.
- b. Visually inspect the Balancer to make sure everything is in place. The Tire Cover should be **up**. If you find any issues, fix them. If there are issues you cannot fix, refer to **Troubleshooting**.
- c. Make sure the Wheel you want to balance is both clean and free of any weights that may have been put on previously. If it is dirty, clean it. Remove any existing weights.

Important: When using Adhesive Weights, it is extremely important to **clean the Wheel**, the cleaner the Wheel, the longer the Adhesive Weight stays in place.

- d. Mount the Wheel on the Balancer.

Refer to **Mounting a Wheel** for mounting instructions, if needed.

- e. Turn the Balancer Off and then back On, to reset, if required. The display should be flashing, and **-a-** will appear in the Inner Display Window.
- f. On the Control Panel, press the **R** button until the **ALU 5** Indication is lit.

Note: **ALU 5** requires manually measuring to input the Inner Plane distance in cm, the Wheel Diameter in inches, and the Wheel Width in cm. Refer to the figures below.

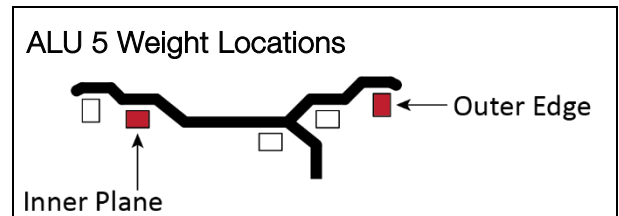

- g. Input the **Inner Plane** Wheel parameter. Slide the inner distance arm to touch the Wheel's Inner Plane and hold it there. Read the distance in cm on the inner arm. Enter this value manually using the **A** key. Return the Inner Measuring Arm to the side of the Balancer.

Manually measure and input the **Wheel Width** in cm using the Caliper. Enter this value using the **B** key.

Manually measure the **Wheel Diameter** in inches or read the diameter off the side of the tire, then enter using the **D** key.

Note: If the values appear incorrect you can turn off the power to reset the machine and start the process over.

- h. Press the **Start** Button; the Wheel spins briefly.

WARNING Stay clear and do not touch the Wheel or the Tire while it is rotating.

- i. Press the **Start** Button on the control panel. The Balancer will automatically stop or you may use the brake pedal to stop the rotation.

The front panel display will show the unbalanced weight correction values for both the Inner Plane and the outer Wheel edge. These values are rounded to the nearest .25 oz. Press **F** to view the actual unbalanced weight without rounding. If either window displays **0.0** no corrective weights are required on that plane.

- j. Check the value on the Inner Window.

- If the value is **0.0**, you do not need to add weight to the Inner Plane.
- If there is a value—**.25**, for example—you need to add that amount of Weight to the Inner Plane.

- k. To add Weight, break off the appropriate number of Adhesive Weight sections.

- l. Manually turn the Wheel, watching the indicators to the **right** of the **Inner Display Window**. The Indicators light up or go out as you move the Wheel.

- m. When all of the Indicators are lit and the Balancer sounds three beeps, press the Brake Pedal to hold the Wheel at that position.

- n. Pull the backing off the Adhesive Weights, then add the Weight to the Wheel at **6 o'clock** on the Inner Plane. If you are adding Adhesive Weights with multiple sections, center them at 6 o'clock.

IMPORTANT Do not touch the adhesive portion of the weights. Oils from your skin or on gloves can reduce the holding power of the adhesive.

- o. Check the value on the Outer Display Window:

- If the value is **0.0**, you do not need to add Weight to the Outer Plane.
- If there is a value—**.25**, for example—you need to add that amount of Weight to the Outer Edge for **ALU 5**).

- p. Manually turn the Wheel, watching the indicators to the **left** of the **Outer Display Window**. The Indicators light up or go out as you move the Wheel.

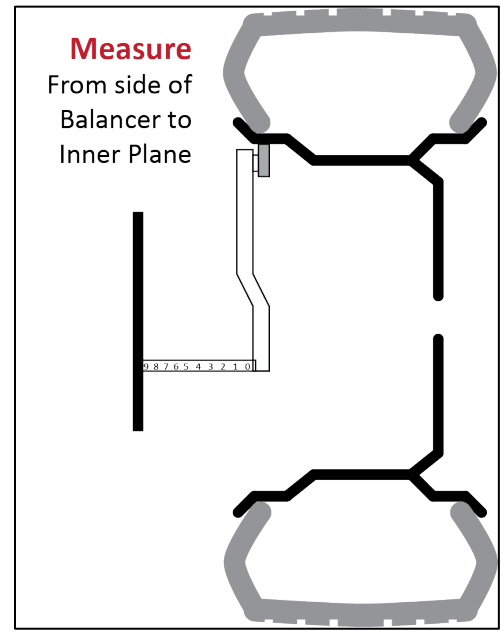

- q. When all of the Indicators are lit and the Balancer sounds three beeps, press the Brake Pedal to hold the Wheel at that position.
- r. Clip the Weight(s) at **Top Dead Center** on the Wheel **12 o'clock high** on the Outer Edge for ALU5.
- s. Release the Brake Pedal.
- t. Press the **Start** Button to spin the Wheel again.

The Wheel is balanced when both the Inner and Outer Windows show **0.0**.

It may take more than one attempt at adding weight(s) to get to **0.0 | 0.0**.

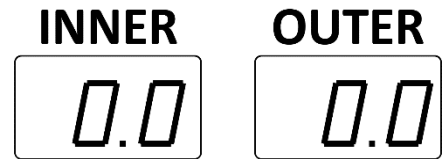

OPT SP Split Weight/Hidden Weight Mode

The Split Weight mode allows the operator to hide correction weights behind Wheel spokes by dividing the weight between two adjacent Wheel spokes.

1. The **OPT SP** mode will only operate in the **ALUS** mode.
2. Weight on the Inner Edge/Plane is applied as usual.
3. Enter **a1, d1** and **a2, d2** automatically using the inner measuring arm. Slide the Inner Measuring Arm out to the Inner Plane for the **a1** and **d1** measurements and hold it there until the Balancer Beeps. Move the inner arm to the Center Plane and hold it there until the Balancer beeps for the **a2** and **d2** measurements.



4. Determine the Wheel width and enter it using the **B** key.
5. Press the **Start** Button.
6. Stop the rotation after test.
7. Manually rotate the Wheel and note where Center Plane correction is supposed to be placed at top dead center. When all the indicators are lit, hold the Wheel in place using the brake. If the correction falls between two spokes and will be visible, you may use the **OPT SP** mode to split the weight and hide it behind two closest Wheel spokes.

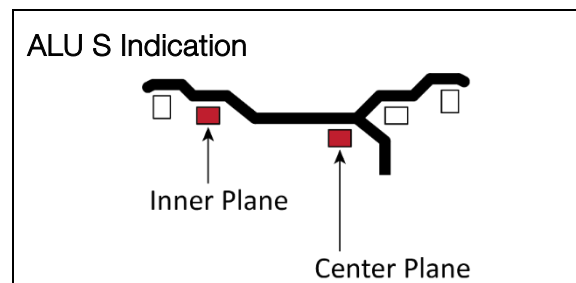

8. Press **OPT SP**.
9. Display will show **SPO -1**.



10. Pull out the inner arm ruler and rotate the Wheel *until the closest spoke is at top dead center and ruler head is behind spoke 1* on the Center Plane. Hold it there for a moment and press **OPT SP** to confirm the **SPO-1** position point.
11. Withdraw the ruler and the display should now show **SPO. --2.**
12. Pull out the ruler and rotate the Wheel until the spoke on the other side of the balance point is at top dead center.
13. *Hold the inner arm against the Center Plane behind the second spoke.*
14. Press **OPT SP** to confirm the selection.
15. Prepare the ½ the required weight to be placed behind spoke.
16. Manually rotate the Wheel until the Outer indicator lights are all lit and the spoke indicator is lit. Hold the Wheel in place using the brake.
17. Attach weights behind the spoke using the **inner measuring arm** and noting the display for position indications.
18. Rotate back to the first spoke. When the indicator lights are all lit, hold the Wheel in place with the brake and use the **inner measuring arm** to place the weights on the Wheel.
19. Run the balance cycle to confirm balance correction.

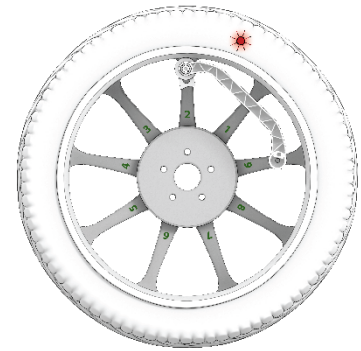
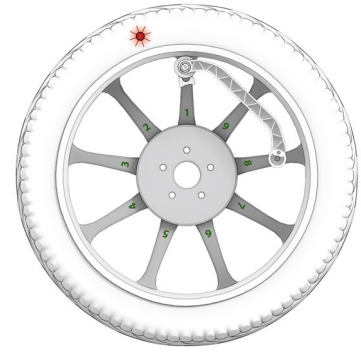

Using the **OPT (Optimize) Function:**

OPT Mode is **not** a balancing mode. The Optimize Function is an *optional* procedure to reduce the imbalance on a Wheel that is more than 30 grams / 1 ounce out of balance. You are not **required** to use the Optimize Function.

Important: The Optimize Function does not bring a Wheel to fully balanced condition. Instead, it lessens the imbalance of a Wheel that is significantly out of balance. Depending on the state of the Wheel, even if you correctly Optimize a Wheel, it may still be more than 1 ounce / 30 grams out of balance when you are done with the Optimize.

To Optimize a Wheel:

1. When you see a weight correction of over 30 grams during a balance, raise the Tire Cover, then rotate the Wheel until the indicators next to the Inner Window are all lit.
2. Press the **OPT SP** button on the Control Panel.

OPT appears on the Display Window and the **OPT** icon on the Display Panel goes on.

The Balancer is now in Optimize Mode.

Important: If you use the Balancer to balance a different Wheel or you turn the Balancer on and off, the Balancer will be taken out of Optimize Mode.

3. Mark the Cone, the Rim at the Cone, the Rim at the Tire, and the Tire itself at the 12 o'clock position.

**Tip**

Mark the tire in such a way that it will come off after balancing, but not come off during the process. Using tape is generally the best method. Pen or pencil usually performs poorly. A pen or pencil mark on tape works best.

4. Remove the Wheel from the Balancer, then use a Tire Changer to take the Tire off the Wheel, rotate the Tire 180°, then put the Tire back on the Wheel and re-inflate.
Make sure not to cover or remove the Marks on the Wheel and Tire.
5. Put the Wheel back on the Balancer, making sure to align the marks on the Cone, the Rim at the Cone, and the Rim at the Tire.
The Mark on the Tire itself will be 180° from the other Marks.
6. Press the **Start** button.
7. When the Wheel stops, turn the Wheel until the Inner Placement Indicators are all lit and the Wheel locks in position.
8. Put a Mark at Top Dead Center on the Wheel Rim.
9. Press **Stop** to release the Wheel, then turn the Wheel until the Outer Placement Indicators are all lit and hold the Wheel in position with the brake.
10. Put a Mark at Top Dead Center on the part of the Tire next to the Wheel Rim.
11. Remove the Wheel from the Balancer, then use a Tire Changer to take the Tire off the Wheel, rotate the Tire so the two Marks you just put on are aligned, then put the Tire back on the Wheel.
12. Put the Wheel back on the Balancer and restart the Balancing process that was interrupted by using the Optimize Function.

Calibration

Calibrate the Balancer using the included 100g weight on a regular basis. When placing weights on Wheels, apply the weight exactly perpendicular to the shaft at the 12 o'clock position. Incorrect placement will result in additional weight call outs and/or an improperly calibrated machine.

1. Install a Wheel and input Wheel Data (Inside Measurement, Diameter and Width) into the Balancer memory.
2. Press the **C** button to enter the calibration mode. The Inner and Outer Display Windows should display the CAL.
3. Press the Start Button twice. The Wheel will rotate. When the motor shuts off use the brake to stop the Wheel motion.
4. Manually spin the Wheel until all the indicator lights on the Outer Position are lit.
5. Place a 100g weight on the outside of the Wheel at the 12 o'clock position.



6. Start the Balancing Machine by pressing the **Start** key. The Wheel will rotate, when the motor shuts off, use the brake to stop the Wheel.

7. Manually spin the Wheel until all the indicator lights on the inner position are lit.
8. Place a 100g weight on the inside of the Wheel at the 12 o'clock position.



9. Start the balancing machine by pressing the Start key. When the motor shuts off, use the brake to bring the Wheel to a stop.
10. The calibration is complete and the unbalanced amount of the Wheel at the last rotation is displayed.

Inner Arm Calibration

The Inner Distance Arm measures the Wheel's distance from the side of the Balancer and the diameter of the Wheel being balanced. The Balancer will return incorrect values if this Arm is out of calibration. If you suspect the Balancer Wheel diameter measurements are inaccurate, calibrate the Inner Distance Arm.

To calibrate the Inner Distance Arm:

1. Clean the Balancer Spindle, Flange, Threaded Shaft and Wheel Mount Surfaces.
2. Install a clean, undamaged Steel Wheel with a diameter between 15 to 18 inches.
3. Move the Power switch to the **ON** position.
4. Press the **C** button to enter the calibration mode. The Inner and Outer Display Windows should display **CAL**.
5. Press the **R** button to select the Inner Distance Arm Calibration. **RULER** will be displayed on the Digital display.
6. Press the **START** button **d16** should be displayed on the left digital display. The actual current Inner Distance Arm measurement will be displayed on the right digital display.
7. Press **D+** or **D-** to change the value displayed in the left display window to match the Wheel's actual diameter.
8. Pull out and rotate the Inner Distance Arm to its measuring position on the Wheel and hold in place.

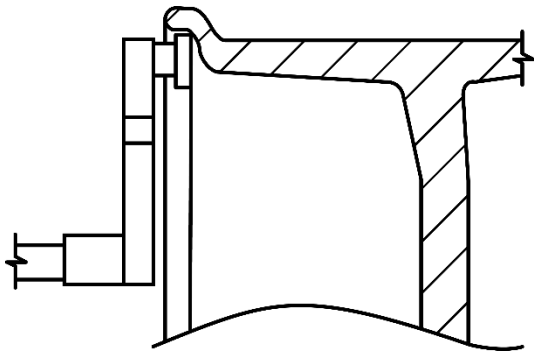

9. Press **START** to confirm the measurement.
10. Return the Inner Distance Arm to the side of the Balancer.
11. The Left Digital Display should now display -15.
12. Pull the Inner Distance Arm out to 15 cm as read on the Distance Arm ruler and hold it in position.
13. Press **START** to confirm the measurement. The digital display should now display **End**.
14. Inner Distance Arm Calibration is complete.

System Parameter Settings

Accessible system parameters include hidden weight rounding, operation sound reminder, display brightness adjustment, tire cover switch, lengthened inner distance measurement.

1. Press **F + Stop** to enter the parameter settings menu.
2. **Adjust the Hidden Weight:** press the up or down arrow to modify the hidden value. Options are 05, 10, and 15. Press **R** to save and move to the next parameter menu item, or press **STOP** to save and exit.



3. **Operation Sound.** Press the up or down arrow to turn the sounds ON or OFF. Press **R** to save and enter the next menu item. Press **STOP** to save and exit parameter menus.



4. **Display Brightness Adjustment.** Press the up or down arrow to adjust the display brightness up and down. Press **R** to save and enter the next parameter menu item. Press **STOP** to save and exit.



5. **Lengthened Inner Distance Arm.** Press the up or down arrow to control this parameter On-Off. Press **R** to save and enter the next parameter menu item. Press **STOP** to save and exit.



When the lengthened distance arm in set is set to **on** the default balancing mode is set to **STA** Static for motorcycle Wheel Balancing. When operating the Balancer the display shows:



Balancer Testing

Three function tests are available.

1. **Display and Sound Test.** Press **C** to enter test functions, press **R** for the next item, and press **STOP** to exit testing.
2. **Piezoelectric Sensor Test.** Press down on the Balancer's shaft. Both Inner and Outer values should change. Press **R** to move to the next item, and press **STOP** to exit.
3. **Optical Partition Test.** Rotate the Balancer shaft manually and the displayed values should change when the shaft is rotated.

Maintenance

Make sure your Balancer is maintained on a regular basis.

⚠ DANGER Disconnect the Balancer from power **before performing any maintenance** and take whatever steps are necessary to make sure the Balancer cannot be re-energized until Maintenance is complete. You could be electrocuted or even killed if the unit is powered back on during Maintenance. If your organization has Lockout/Tagout policies, make sure to implement them before beginning Maintenance.

To maintain your Wheel Balancer:

- **Daily:** Make sure the unit is clean and dry; clean it after each use.
- **Weekly:** Make sure the Shaft Assembly is correctly aligned with the Shaft Housing and is securely tightened.

Shaft installation

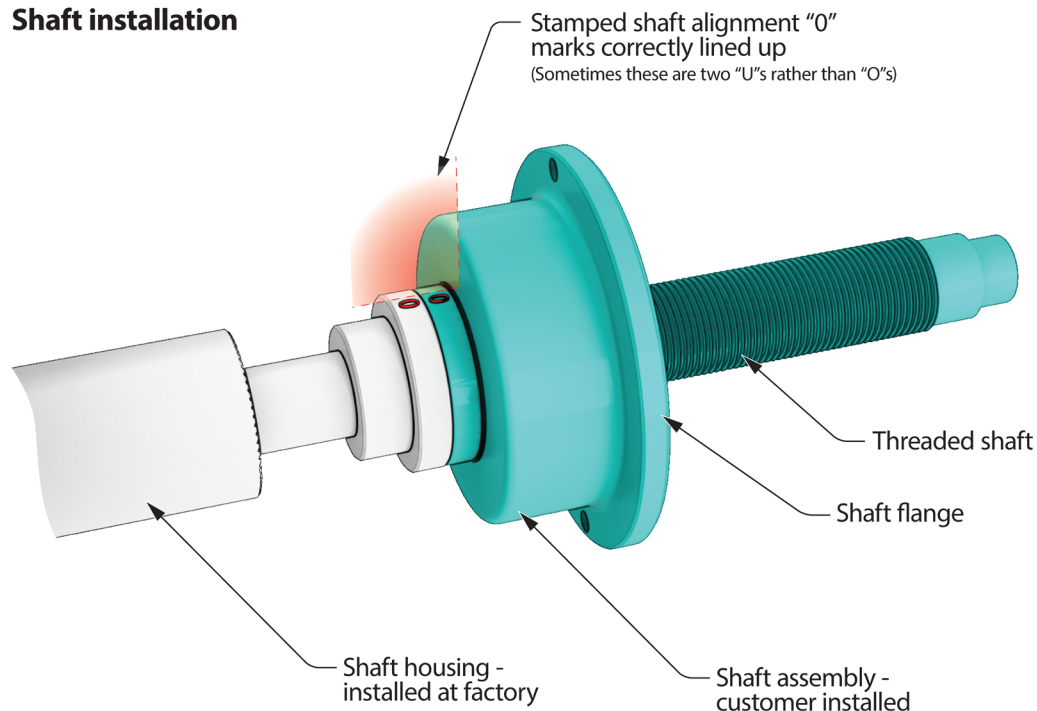

- **Monthly:** Make sure all Anchor Bolts are tightened and secure.
- **Monthly:** Check all components to make sure they are in good operating condition. If you find a component that is **not** working correctly, take the unit out of service and refer to **Troubleshooting** for more information.
- **Every three months:** Check the bolts on the components attached to the rear of the unit to make sure they are tight and secure.
- **Yearly:** Take the unit out of service, disconnect the Balancer from its power source, and then thoroughly check and clean all components.

⚠ WARNING Do not operate your Balancer if you find issues; instead, take the unit out of service, then contact your dealer, visit [APEX.com/support](https://www.apex.com/support), call APEX at **(877) 432-6627**, or email support@Bendpak.com.

Troubleshooting

⚠ DANGER Disconnect the Balancer from power **before performing any troubleshooting or maintenance procedures** and take whatever steps are necessary to make sure the unit cannot be re-energized until Troubleshooting is over. Because the unit uses electricity, you could be electrocuted or even killed if the unit is powered back on during a Troubleshooting procedure. If your organization has Lockout/Tagout policies, make sure to implement them before beginning any Troubleshooting.

Perform the following checks if you are experiencing balancing problems:

- Confirm the location and alignment of the alignment marks on the Shaft Assembly and Shaft Housing (see **Installing the Shaft** for more information).
- Make sure the Balancer is anchored (see **Anchoring the Balancer** for more information).
- Perform a calibration. Perform the calibration with an undamaged steel Wheel of the most commonly used size.

Note: It is good practice to keep a known good Wheel of the most commonly used size to use as a calibration / reference tire to assist in troubleshooting.

- Verify the calibration weight used is a 100 gram or 3.5 ounce weight and that is mounted correctly during the calibration procedure.

Issues

Issue	Action
Nothing on the Display Panel.	Make sure the Balancer is turned on and supplied power.
The Balancer is not producing good balances on a consistent basis.	Perform the Calibration Procedure. Refer to the Calibration section for more information.
Vibration persists after balancing.	A weight has come off; replace it. Tire is slipping on the Wheel (possible Tire Changer issue); have Tire remounted and then rebalanced. Stones or other objects caught in Tire tread; remove the objects, rebalance if necessary.

Error Codes

Error Code	Cause	Solution
Err-01	Optical display error, Power board error, motor error.	<ol style="list-style-type: none"> 1. If error 1 occurs and the Shaft can rotate, replace the optical display. 2. If error 1 occurs and the shaft cannot rotate, it may be due to either power board error or motor error.
Err-02	No tire or belt is too tight.	Install Wheel or adjust belts.
Err-03	Excessive unbalanced tire quality.	Check whether the Wheel is aligned and whether there are foreign bodies on the Wheels.
Err-04	Wheel runs in reverse.	Check motor wiring.
Err-05	Unused	Unused
Err-06	User has pressed the Stop key.	Press the stop key again to clear the error, and retest.
Err-10	No 100g weight was added in step 2 of self-calibration.	Run the calibration sequence again installing the weights correctly.
Err-11	No 100g weight or sensor wiring error in the third step of self-calibration.	Run the calibration sequence again installing the weights correctly.
Err-15	Parameter storage error.	Replace the power board.
Err-20	Integrated circuit damage.	Replace CPU board.

If you continue to have problems with your Wheel Balancer, visit [APEX.com/support/](https://www.apex.com/support/) call APEX at **(877) 432-6627**, or email support@Bendpak.com

Labels

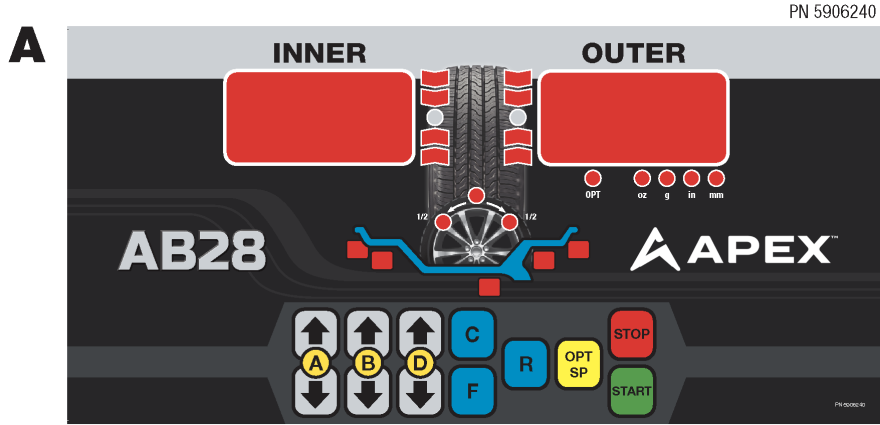

Apex AB28 Balancer Membrane 5906240-REV-01
Size: 340 mm (W) x 165 mm (H)



Apex Branding Decal
Size: 6.5 in. W x 1.3 in. H
Grey indicates background surface, not label



AB28 TruBalance Front Cover Decal 5906242
Size: 21.5 in. W x 3 in. H
Grey indicates background surface, not label

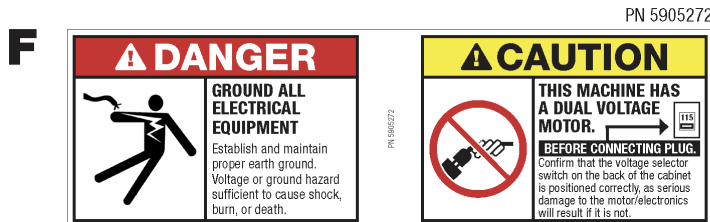

Voltage Plug Danger Label 5905272-REV-B
Size: 6.5 in. W x 2 in. H

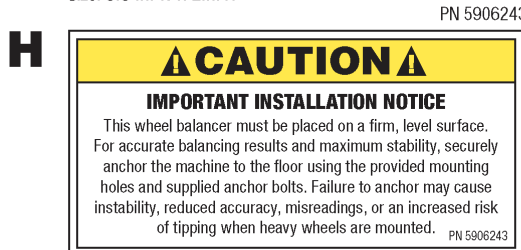

Wheel Service Installation Notice Label 5906243
Size: 3 in. W x 1.5 in. H

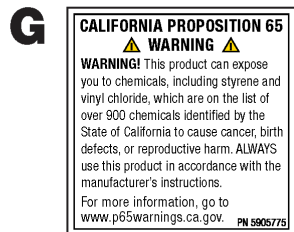

Prop_65_Label-5905775_Rev_01
Size: 1.5 in. W x 1.5 in. H

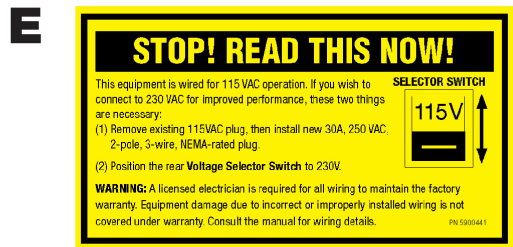

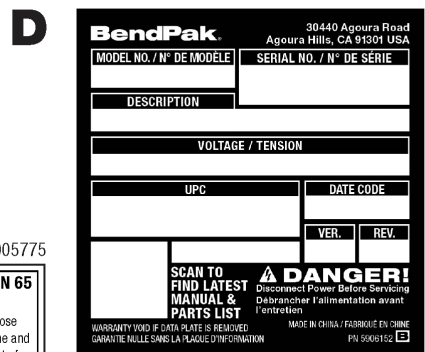

RNGR Volt Caution Decal_115V_5900441
Size: 4.5 in. W x 2.5 in. H

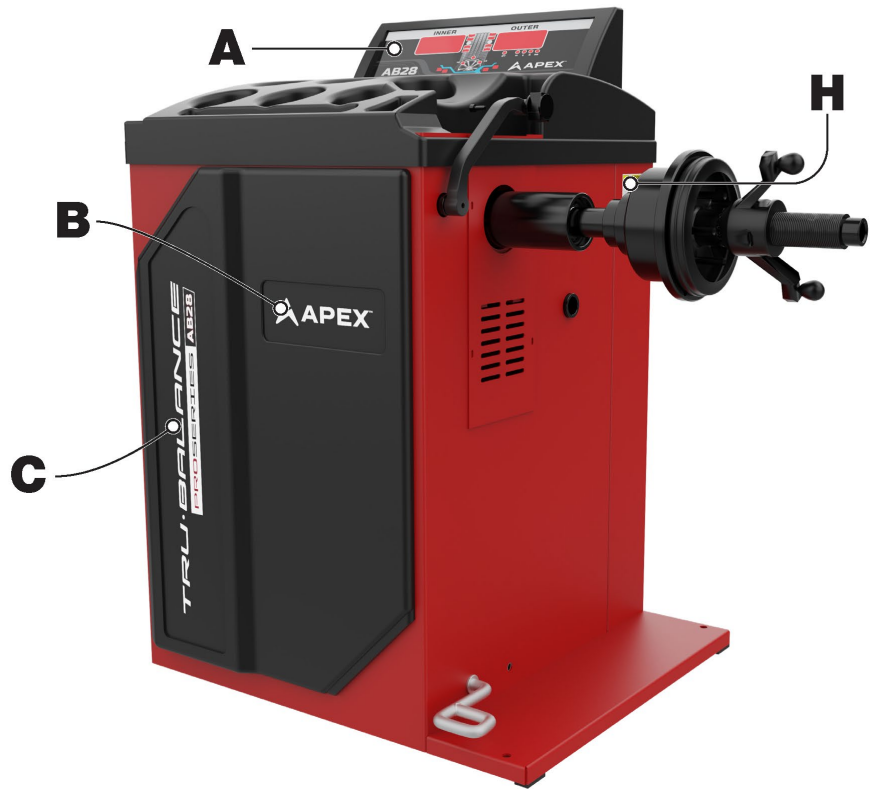

Ranger-CoolBoss_3x3-Namplate Label_B 5906152
Size: 3 in. W x 3 in. H



MACHINE PAINT COLORS	
	RAL 9017 (20% Gloss)
	RAL 3003 (20% Gloss)

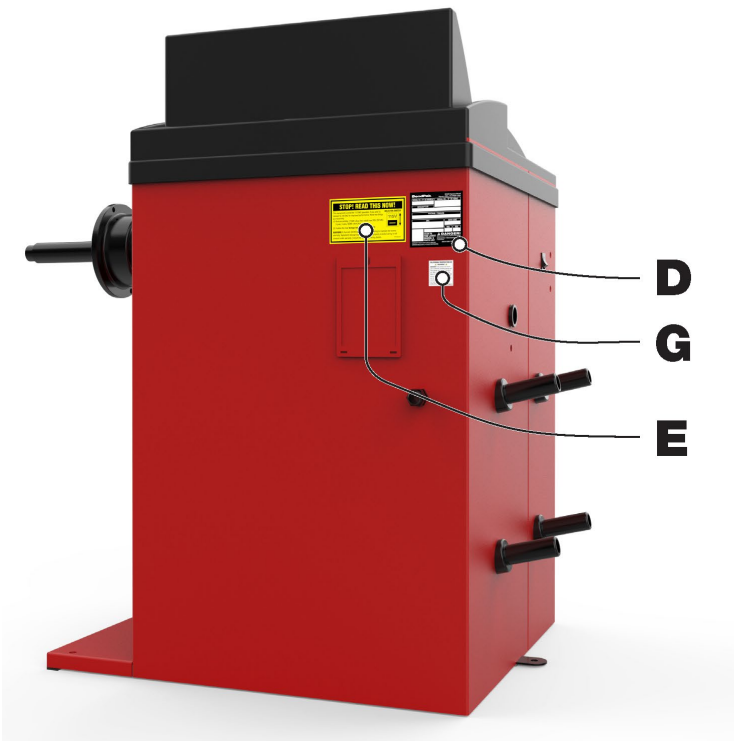

Wrap around end of power Cord

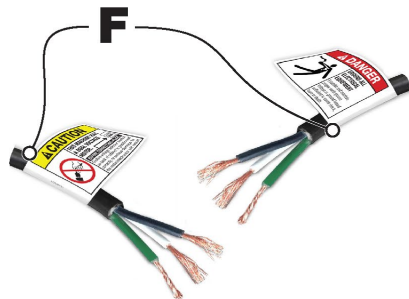

Parts

Cabinet Assy

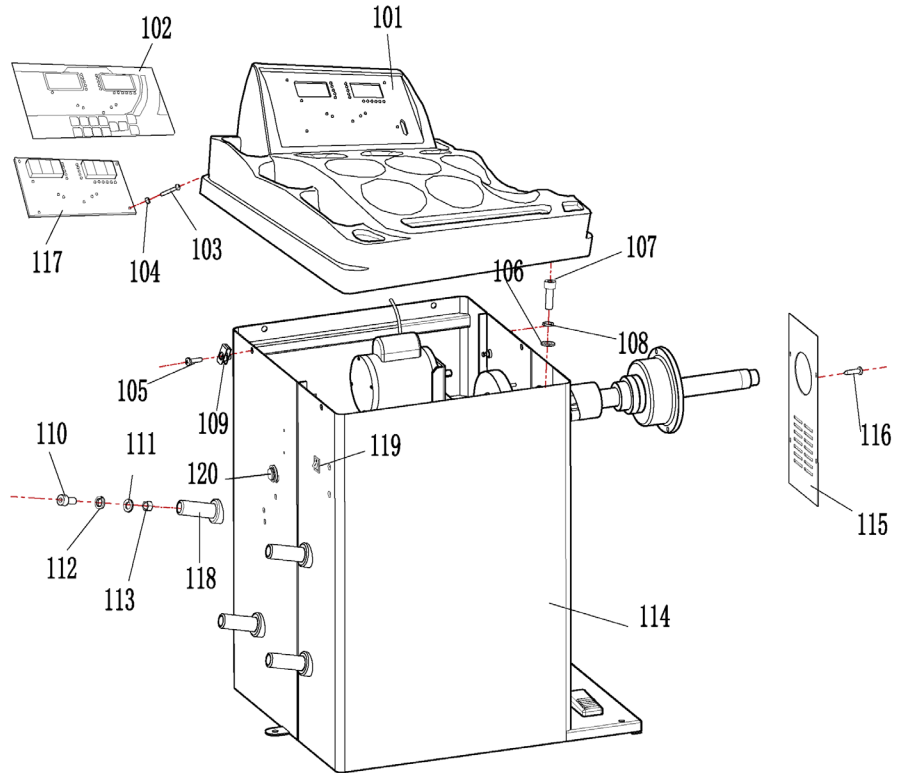

Cabinet Assy. Parts List

#	Part Number	Description
101		Weight Tray
102		Display Membrane
103		Cross Recessed Pan Head Screw M3 x 25
104		Hex Nut M3
105		Hex Socket Head Screw M6 x 20
106		Spacer $\Phi 8$
107	5530304	SHCS M8 x 20
108		Washer, $\Phi 8$ Split Lock
109		Clip (Reed) Nut, M6
115		SHCS M6 x 25
111		Washer $\Phi 6$
112		Washer, $\Phi 6$ Split Lock
113		Hex Nut M6
114		Cabinet
115		Dam-board
116		Cross Recessed Pan Head Screw M4 x 16
117		Display Board
118	5327132	Cone hangar
119	5525251	On-Off switch
120		Block

Main Shaft Assy.

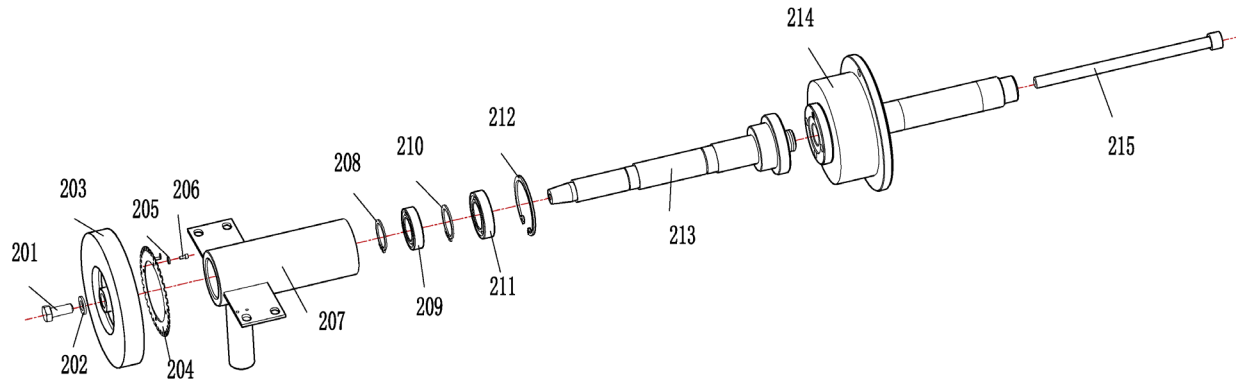

Main Shaft Assy. Parts List

#	Part Number	Description
201		Hexagon Bolt M10 x 40
202		Washer Φ 10
203		Motor Pulley
204		Photoelectric Tooth
205		Washer, Φ 4 Split Lock
206		SHCS M4 x 12
207		Spindle Bushing Welding Parts
208		Snap Ring Φ 30
209		Bearing
210		Snap Ring Φ 35
211		Bearing
212		Circlip for Hole Φ 62
213		Threaded Shaft
214		Matcher
215	5327182	SHCS M14 x 240

Pressure Sensor Assy.

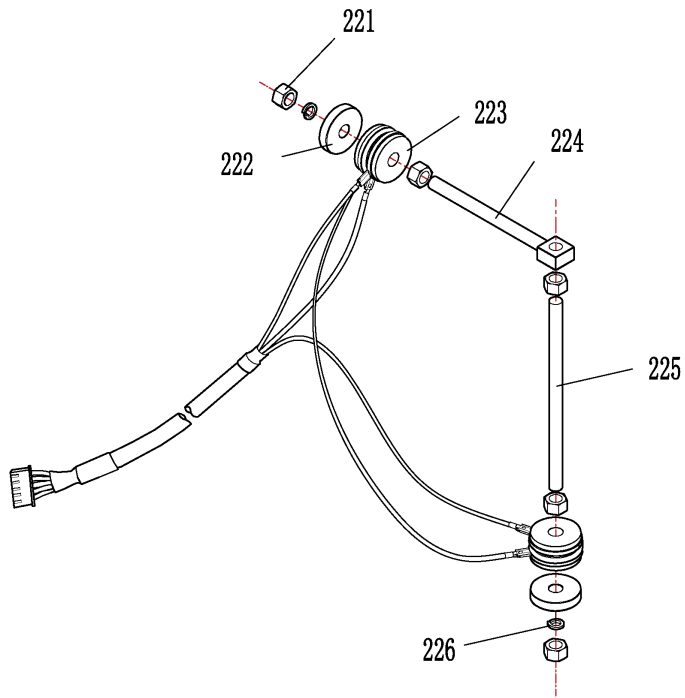

Pressure Sensor Assy. Parts List

#	Part Number	Description
221		Hexagon Bolt M10
222		Piezo Sensor Pad
223	5328539	Piezo Sensor
224		Piezo Horizontal Shaft
225		Piezo Vertical Shaft
226		Spring Washer M10

Motor Assy.

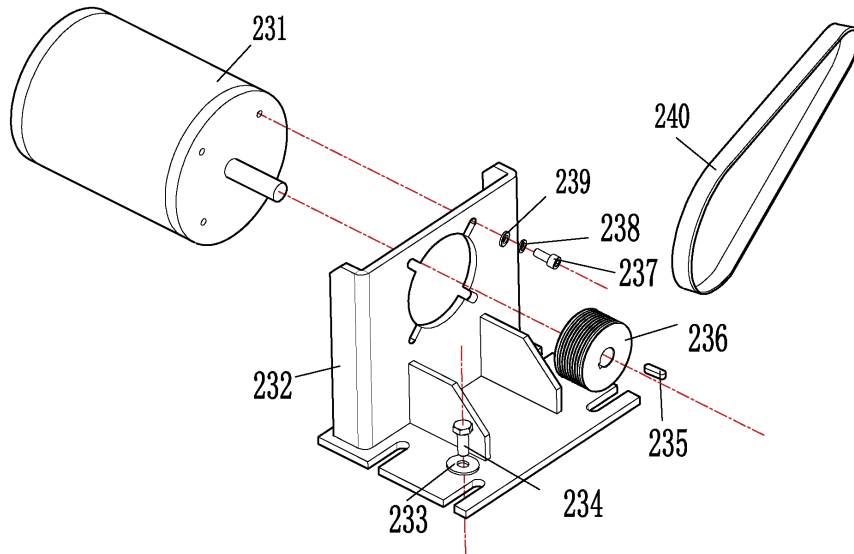

Motor Assy. Parts

List

#	Part Number	Description
231	5327092	Motor
232		Motor Cabinet
233		Pad $\Phi 8$
234		SHCS M8 x 30
235	5327145	Flat Key 5 x 5 x 30
236	5327144	Motor Belt Pulley
237		SHCS M6 x 16
238		Spring Washer $\Phi 6$
239		Washer $\Phi 6$
240		V- Belt

Encoder (Encored) Board Part

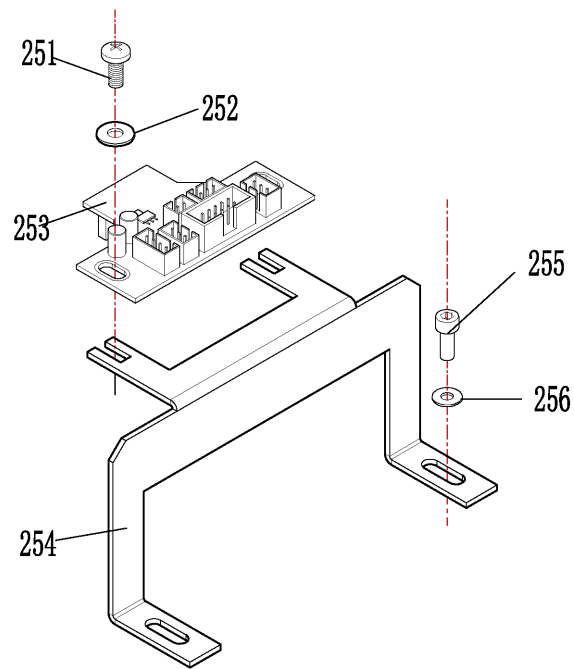

Encoder Board Parts List

#	Part Number	Description
251		Cross recessed Pan Head Screw M3 x 10
252		Washer M4
253	5328544	Encoder (Encored) Board
254		Encoder (Encored) Bracket
255	5327870	SHCS M4 x 8
256	5327144	Washer M4

Computer Board Assembly

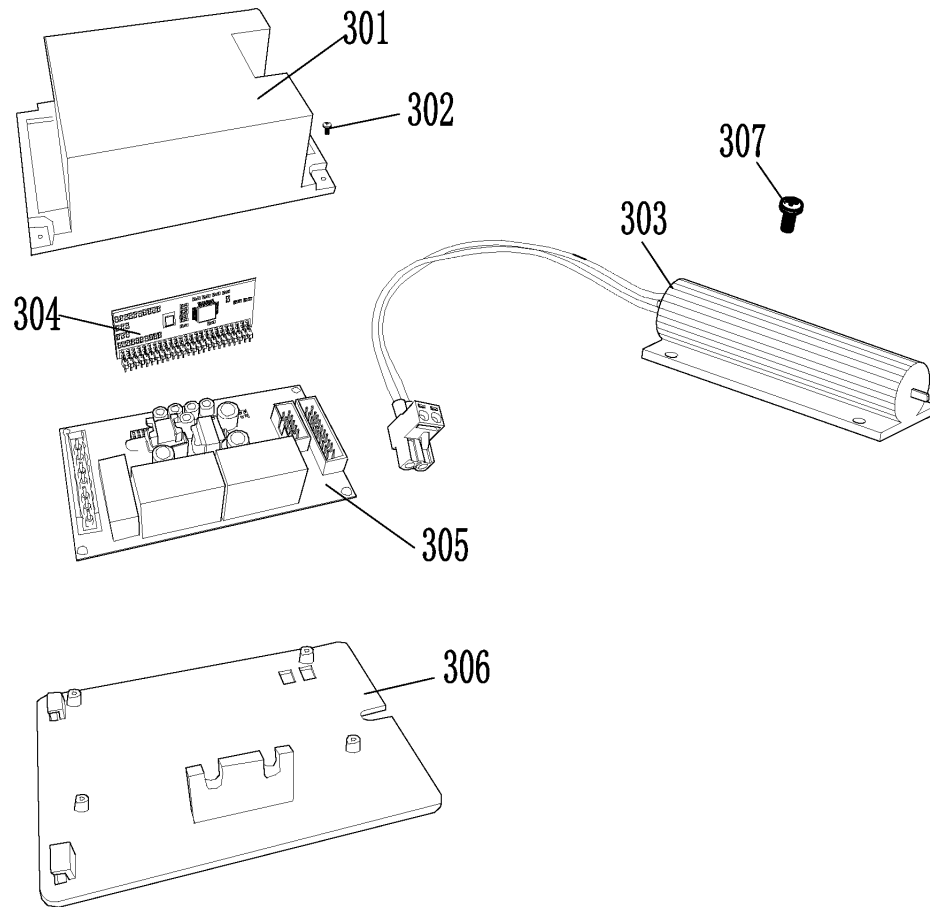

Computer Board Assembly Parts List

Part Number	#	Description
	301	CPU Board Box Cover
	302	Cross Recessed Pan Head Tapping Screw ST 2.2 x 6.5
5327147	303	Brake resistance
5328547	304	Digital Tube CPU
5328548	305	Power Board
	306	CPU Board Cassette Holder
	307	Recess Head Screw

Inner Distance Arm Assy.

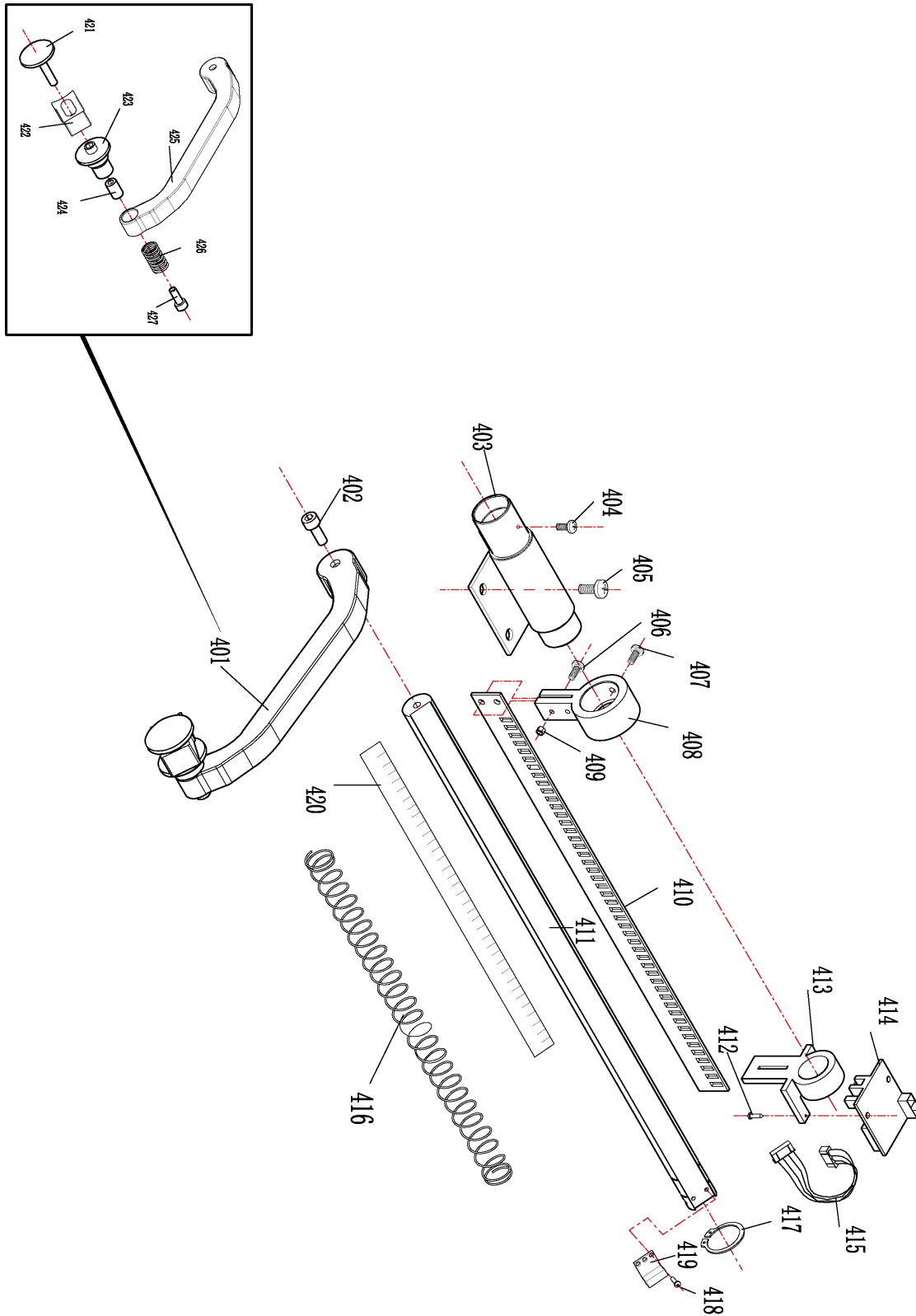

Inner Distance Arm Assy. Parts List

Part Number	#	Description
	401	Distance Arm Head Connect Rod Assy.
	402	SHCS M6 x 12
	403	Welding Parts For Ruler Bushing
	404	Cross Recessed Pan Head Screw M3 x 10
	405	SHCS M6 x 10
	406	Cross recessed Pan Head Screw M3 x 20
	407	Cross Recessed Pan Head Screw M4 x 10
	408	Raster Mounting 1
	409	Nut M3
	410	Article Grating
	411	Grating Bending Ruler Rod
	412	Cross Recessed Pan Head Self-Acting Screw ST2.2 x 6.5
	413	Raster Mounting 2
5328549	414	Draw Ruler Straight Grating Circuit Board
5328550	415	Draw Wire
	416	Inner Distance Pressure Spring
	417	Snap Ring Φ 20

	418	Cross Recessed Pan Head Screw M3 x 8
5328551	419	Inclination Sensor
	420	Rack
	421	Axis
	422	End Sliding Block
	423	Thread Bushing
	424	Pivot Bush Unit
	425	Pull Rod Bent Rod
	426	End Compression Spring
	427	SHCS M5 x 20

Brake Assembly

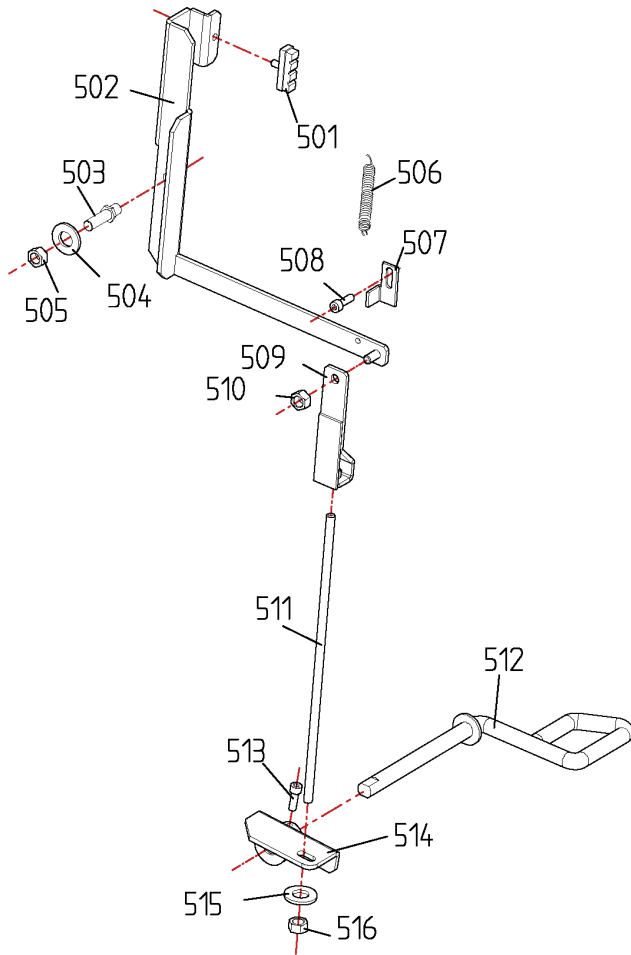

Part Number	#	Description
5346879	501	Brake Rubber Block
	502	Brake Lever
	503	Lever Shaft
	504	Pad M10
	505	Lock Nut M10
5328286	506	Brake Tension Spring
5327061	507	Brake Baffle
5327172	508	SHCS M6x16
5327073	509	Bent Plate Assembly Welding Piece
5327720	510	Lock Nut M8
5346425	511	Brake Pull Rod
	512	Brake Pedal Assembly Welded
5402187	513	SHCS M6x25
	514	Swing Rod Assembly Welding Piece
	515	Pad M8
5327063	516	Lock Nut M8

Wiring Assy.

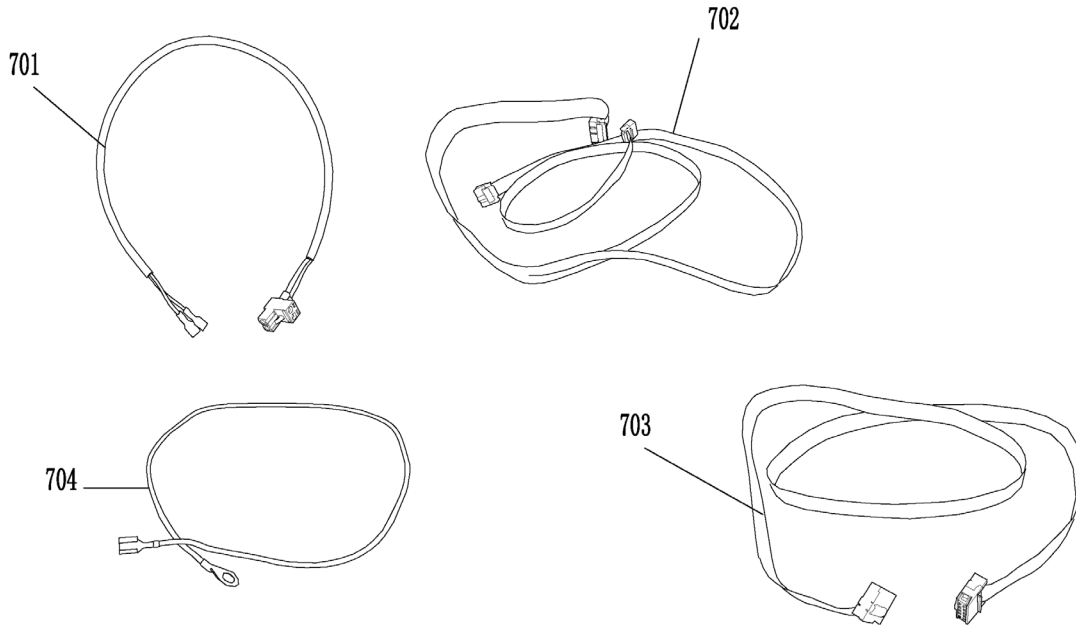

Wiring Assy. Parts List

Part Number	#	Description
	701	Power Line
	702	Gauge Wire
	703	Measuring Arm Harness (Draw the Ruler to Reach the Tire)
	704	Ground Electrode

Accessories

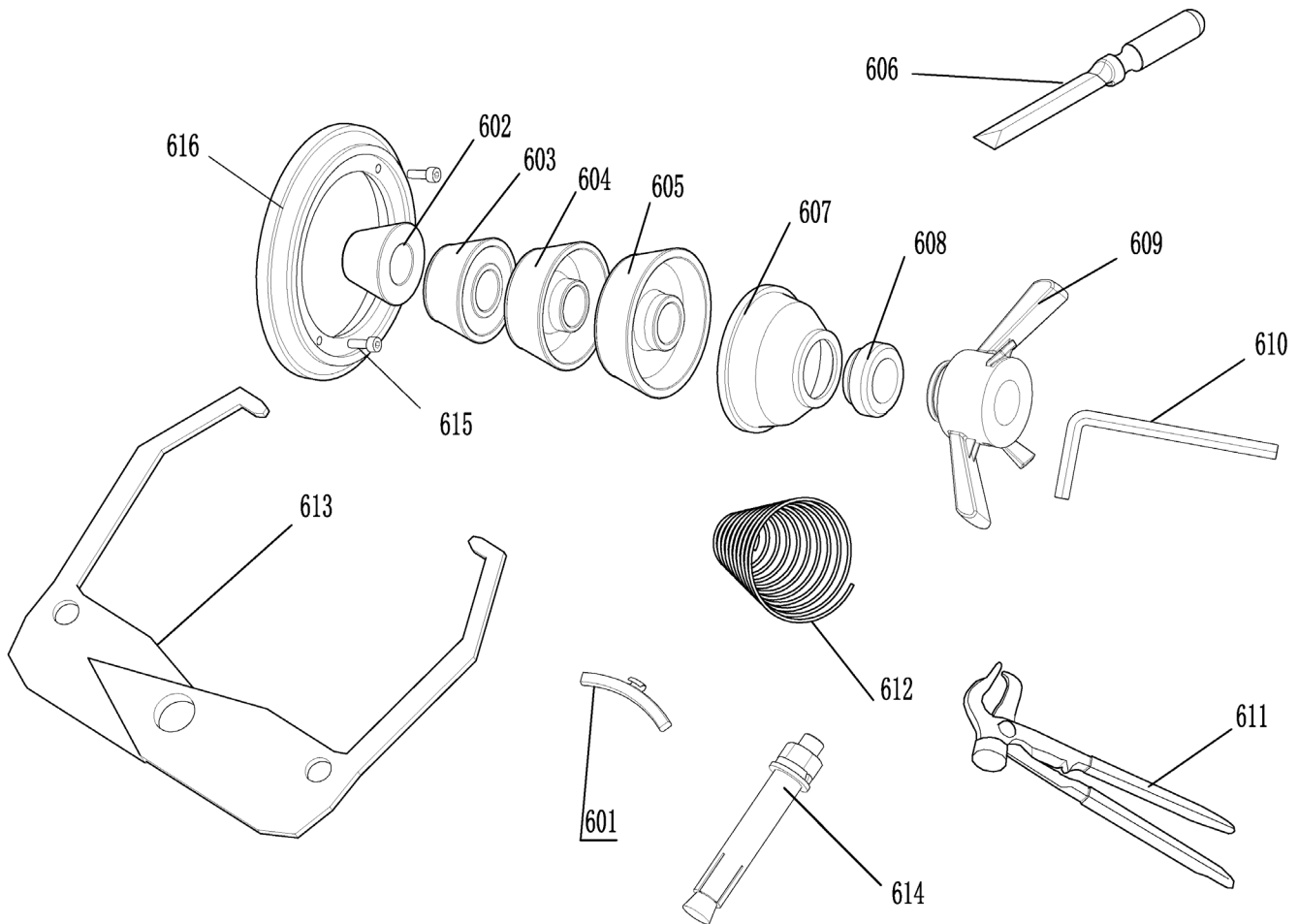

Accessories Parts List

Part Number	#	Description
5346879	601	Calibration Weight
	602	Cone 1
	603	Cone 2
	604	Cone 3
	605	Cone 4
5328286	606	Weight removal tool
5327061	607	Quick Nut Cup
5327172	608	Quick Nut Cover
5327073	609	Quick Release Nut
5327720	610	Allen Wrench
5346425	611	Wheel Weight Tool (Weight Hammer Pliers)
	612	Cone Spring (Tower of Spring)
5402187	613	Wheel Width Caliper
	614	Anchor Bolt (Expansion Bolt) M8 x 100
	615	SHCS M8x20
5327063	616	Thin Plate

Wiring

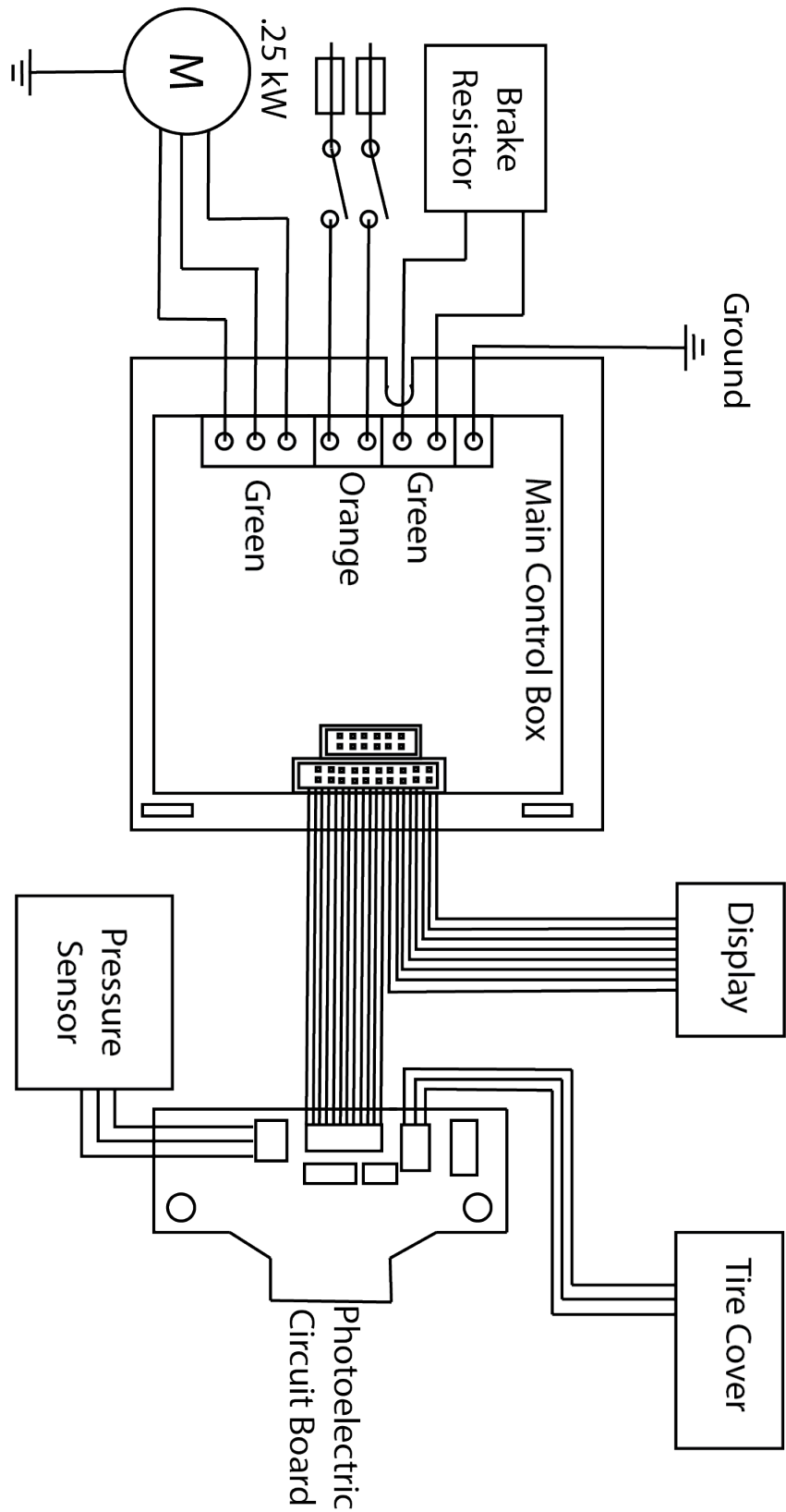



30440 Agoura Road
Agoura Hills, CA 91301 USA
bendpak.com/apex