

## Wheel Balancer

# Installation and Operation Manual

Manual P/N 5900608 — Revision A — January 2026

Model:

- AB24M

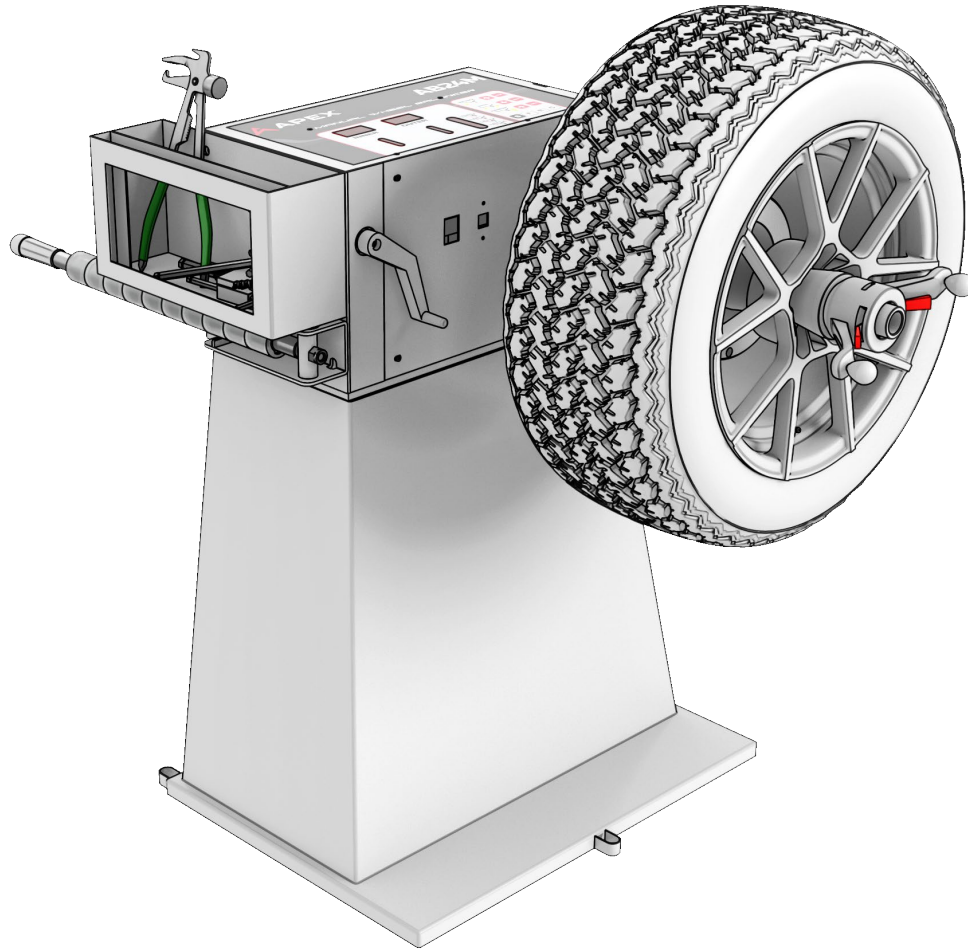

*Shown with optional stand.*

 **DANGER**

**Read the *entire contents* of this manual *before* using this product.** Failure to follow the instructions and safety precautions in this manual can result in serious injury or death. Make sure all other operators also read this manual. Keep the manual near the product for future reference. ***By proceeding with setup and operation, you agree that you fully understand the contents of this manual and assume full responsibility for product use.***

**Manual.** AB24M Wheel Balancer, Installation and Operation Manual, P/N 5900608, Revision A, released January 2026.

**Copyright.** Copyright © 2026 by APEX BendPak Inc. All rights reserved. You may make copies of this document if you agree that: you will give full attribution to BendPak APEX Inc., you will not make changes to the content, you do not gain any rights to this content, and you will not use the copies for commercial purposes.

**Trademarks.** BendPak, the BendPak logo, APEX, and the APEX logo are registered trademarks of BendPak Inc. All other company, product, and service names are used for identification only. All trademarks and registered trademarks mentioned in this manual are the property of their respective owners.

**Limitations.** Every effort has been made to have complete and accurate instructions in this manual. However, product updates, revisions, and/or changes may have occurred since this manual was published. BendPak APEX reserves the right to change any information in this manual without incurring any obligation for equipment previously or subsequently sold. BendPak APEX is not responsible for typographical errors in this manual. Feel free to contact us at any time to get the latest information about any product: [BendPak.com/apex](https://BendPak.com/apex).

**Warranty.** The BendPak APEX warranty is more than a commitment to you: it is also a commitment to the value of your new product. For full warranty details, contact your nearest BendPak APEX dealer or visit [APEX Products Warranty](#).

**Safety.** Your new product was designed and manufactured with safety in mind. Your safety also depends on proper training and thoughtful operation. Do not set up, operate, maintain, or repair the unit without reading and understanding this manual and the labels on it; ***do not use this product unless you can do so safely!***

**Owner Responsibility.** In order to maintain your product properly and to ensure operator safety, it is the responsibility of the product owner ***to read and follow these instructions***.

- Follow all setup, operation, and maintenance instructions.
- Make sure product setup conforms to all applicable local, state, and federal codes, rules, and regulations, such as state and federal OSHA regulations and electrical codes.
- Read and follow all safety instructions. Keep them readily available for operators.
- Make sure all operators are properly trained, know how to safely operate the unit, and are properly supervised.
- Do not operate the product until you are certain that all parts are in place and operating correctly.
- Carefully inspect the product on a regular basis and perform all maintenance as required.
- Service and maintain the unit only with approved replacement parts.
- Keep the manual with the product and make sure all labels are clean and visible.
- **Only use this product if it can be used safely!**

**Unit Information.** Enter the Model Number, Serial Number, and the Date of Manufacture from the label on your unit. This information is required for part or warranty issues.

Model: \_\_\_\_\_

Serial: \_\_\_\_\_

Date of Manufacture: \_\_\_\_\_

---

# Table of Contents

<b>Introduction</b> .....	<b>3</b>	<b>Operation</b> .....	<b>24</b>
<b>Shipping Information</b> .....	<b>4</b>	<b>Maintenance</b> .....	<b>44</b>
<b>Safety Considerations</b> .....	<b>4</b>	<b>Troubleshooting</b> .....	<b>45</b>
<b>Components</b> .....	<b>6</b>	<b>Wiring Diagram</b> .....	<b>48</b>
<b>FAQ</b> .....	<b>8</b>	<b>Labels</b> .....	<b>49</b>
<b>Specifications</b> .....	<b>9</b>	<b>Parts</b> .....	<b>51</b>
<b>Installation Checklist</b> .....	<b>10</b>	<b>Maintenance Log</b> .....	<b>59</b>
<b>Installation</b> .....	<b>11</b>		

## Introduction

This manual describes the installation and operation of the APEX AB24M Wheel Balancer. The AB24M is a computer-based Wheel Balancer that provides fast, accurate Wheel balancing for a wide variety of Wheels. No internal motor is utilized; Wheels are spun manually. The Balancer is designed to accommodate mounting in three different configurations. A Tire Changer mount is shipped with the Balancer, but an optional mounting stand, and an optional wall mount are also available.

More information about APEX products is available at [Bendpak.com/apex](http://Bendpak.com/apex).

***This manual is mandatory reading for all users*** of the AB24M , including anyone who sets up, operates, maintains, or repairs it.

You can always find the latest version of your product's [manual on the Bendpak website](#).

**⚠ DANGER** Be very careful when setting up, operating, maintaining, or repairing this equipment; failure to do so could result in property damage, product damage, injury, or (in very rare cases) death. Make sure only authorized personnel operate this equipment. All repairs must be performed by an authorized technician. Do not make modifications to the unit; this voids the warranty and increases the chances of injury or property damage. Make sure to read and follow the instructions on the labels on the unit.

Keep this manual on or near the equipment so that anyone who uses or services it can read it.

Technical support and service for your Wheel Balancer is available from your distributor or by calling APEX at **(877) 432-6627**. You may also call regarding parts replacement (please have the serial number and model number of your unit available).

---

# Shipping Information

Your equipment was carefully checked before shipping. Nevertheless, you should thoroughly inspect the shipment **before** you sign to acknowledge that you received it.

When you sign the bill of lading, it tells the carrier that the items on the invoice were received in good condition. **Do not sign the bill of lading until after you have inspected the shipment.** If any of the items listed on the bill of lading are missing or damaged, do not accept the shipment until the carrier makes a notation on the bill of lading that lists the missing or damaged goods.

If you discover missing or damaged goods **after** you receive the shipment and have signed the bill of lading, notify the carrier at once and request the carrier to make an inspection. If the carrier will not make an inspection, prepare a signed statement to the effect that you have notified the carrier (on a specific date) and that the carrier has failed to comply with your request.

It is difficult to collect for loss or damage after you have given the carrier a signed bill of lading. If this happens to you, file a claim with the carrier promptly. Support your claim with copies of the bill of lading, freight bill, invoice, and photographs, if available. Our willingness to assist in helping you process your claim does not make us responsible for collection of claims or replacement of lost or damaged materials.

## Safety Considerations

**Read this manual carefully before using your new product.** Do not set up or operate the product until you are familiar with all operating instructions and warnings. Do not allow anyone else to operate the product until they are also familiar with all operating instructions and warnings.

### Safety Information

Please note the following:

- The product is a Wheel Balancer. **Use it only for its intended purpose.**
- Do not make any modifications to the product; this voids the warranty and increases the chances of injury or property damage.
- The product should only be operated by authorized personnel. Keep children and untrained personnel away from the product.
- When using the product, wear appropriate work clothes (*nothing loose*) and ANSI-approved safety goggles (or similar). Keep hair, jewelry, ties and clothing away from the Balancer.
- When a Wheel is spinning, keep away from it.
- Do not use the product while tired or under the influence of drugs, alcohol, or medication.
- Do not use the product in the presence of cigarette smoke, dust, or flammable liquids or gases. Use the product indoors in a well-ventilated area.
- Make sure all operators read and understand the *Installation and Operation Manual*. Keep the manual near the device at all times.
- Make a visual inspection of the product before using it each time. Do not use the product if you find any missing or damaged parts. Instead, take the unit out of service, then contact an authorized repair facility, your distributor, or APEX Products at **(877) 432-6627**.
- APEX recommends making a **thorough** inspection of the product once a month. Replace any damaged or severely worn parts, decals, or warning labels.

---

## Symbols

Following are the symbols that may be used in this manual:



**DANGER**

Calls attention to a hazard that **will** result in death or injury.



**DANGER**

Calls attention to an electrical shock hazard that **will** result in death or injury.



**WARNING**

Calls attention to a hazard or unsafe practice that **could** result in death or injury.



**CAUTION**

Calls attention to a hazard or unsafe practice that could result in personal injury, product damage, or property damage.

**NOTICE**

Calls attention to a situation that, if not avoided, could result in product or property damage.



**Tip**

Calls attention to information that can help you use your unit better.

## Liability Information

APEX assumes **NO** liability for injury, death or damages resulting from:

- Use of this equipment for purposes other than those described in this Manual.
- Modifications to the equipment without prior, written permission from APEX.
- Injury or death caused by modifying, disabling, overriding or removing safety features.
- Damage to the equipment from external influences.
- Incorrect operation of the equipment.

---

# Components

Balancer components include:

- **Display and Control Panel.** Displays balance weight and mode information.
- **Inner Measuring Arm / Distance Ruler.** Used to find the Distance between the Balancer and the inner edge of the Wheel being balanced.
- **Power Switch.** (Not shown) Turns the Balancer on and off.
- **Storage Tray.** Storage for Clip-On Weights and other items you want to have handy.
- **Cone Hangers.** (Not shown) Hold the AB24M Wheel Mounting Cones when not in use.

## Components

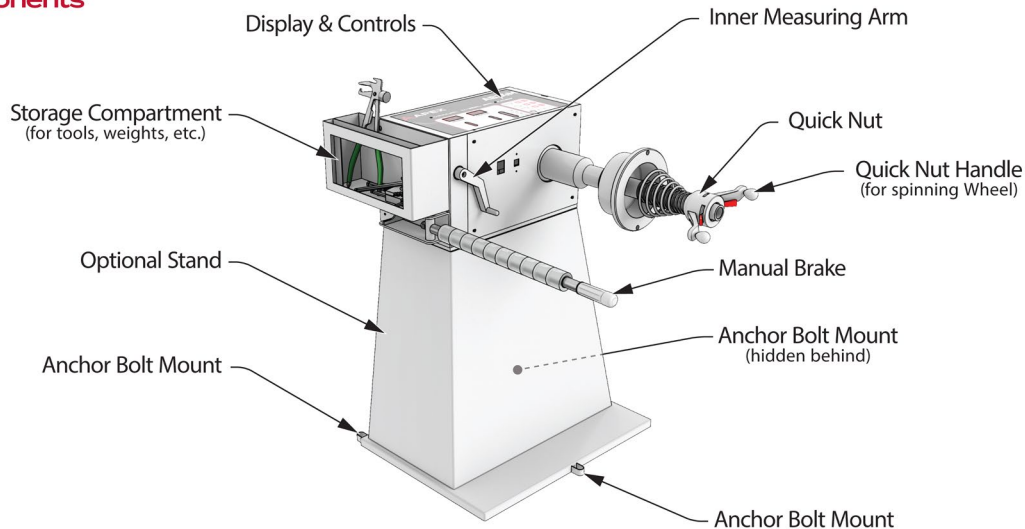

*Not all components visible in the photo above.*

Balancer accessories include:

- **Quick-Release Hub Nut.** Holds the Wheel on the Balancer, once the Wheel is mounted.
- **Hex Key Wrench Set.** Used during installation. Hex key wrenches are sometimes called Allen® wrenches.
- **Anchor Bolts.** Anchor the Balancer to the floor at the desired location.
- **Wheel Weight Tool.** Used to install and remove Clip-On Weights.
- **Weight Removal Tool.** Used to remove Adhesive Weights.
- **Mounting Spring.** Secures the Wheel when using Rear- and Dual-Cone Mounting.
- **Inner and Outer Gauge Calibration Weight.** Used for calibrating the unit, when necessary.
- **Mounting Cone Assortment.** Supports a wide range of Wheel sizes.
- **Wheel Width Calipers.** Used to measure the Width of a Wheel.
- **Spacer Ring.** Attaches to the Shaft Flange for larger Wheels only.

All of the Balancer accessories are shown and identified in the [Parts](#) section of this manual.

---

Other terms you need to understand include:

- **Wheel.** A circular metal piece that attaches to an axle and rotates.
- **Tire.** A circular rubber piece that surrounds and attaches to a Wheel; more specifically, to the Rim, which is the part of the Wheel that directly touches the Tire. Most Tires are pneumatically inflated (filled with a gas, such as air, helium, or nitrogen) and made out of rubber (synthetic or natural).
- **Rim.** The part of a Wheel that directly attaches to a Tire; almost always the outer portion of the Wheel. Because modern Wheels are frequently created from a single piece of metal, “Wheel” and “Rim” are sometimes used interchangeably.
- **Hub.** The part of a Wheel that is not the Rim; the central portion of the Wheel.
- **Imbalance.** An unbalanced weight distribution in a Wheel; it can cause uneven rotation (which results in Wheel wobble, uneven Tire wear, and Vehicle vibration). ***To correct an imbalance, a weight must be applied opposite the imbalance.***
- **Planes.** When a Wheel is figuratively divided down the middle into two sections, it creates two planes; called Inner and Outer (see [About Wheel Planes](#) for more information). Balancing is more effective when planes are analyzed for imbalance separately (and addressed separately), called Dynamic Balancing. Inner and Outer planes are ***not*** the same as the specific locations on the Wheel where Weight can be added, identified as Inner Edge, Inner Plane, Center Plane, Outer Plane and Outer Edge.
- **Clip-On Weights.** Metal weights that are held in place on the Wheel by clipping them to the Inner or Outer Edge. ***Older Clip-On Weights made of lead should not be used*** as they are a hazard to the environment; they are also illegal to use in many countries and some states in the U.S.
- **Adhesive Weights.** Weights that are flat and held in place on the Wheel with adhesive; they get placed on the Inner, Outer, or Center Plane. Adhesive Weights come in both black and gray, making them harder to see.
- **Placement Indicators.** Light up when the ideal weight location is reached.
- **Balancing Modes.** The Balancer supports Dynamic Balancing, Static Balancing, and Aluminum Alloy Balancing Modes.
- **Dynamic Balancing.** Balancing a steel Wheel where each of the two planes are analyzed separately. If there is an imbalance, the two planes are brought back into balance separately. Dynamic Balancing is a more recent technology than Static Balancing and generally produces a better balance.
- **Static Balancing.** Balancing a Wheel as a whole; that is, on a single plane only. Static Balancing is required for motorcycle Wheels and older Wheels that are 4 inches wide or less; also used if only Adhesive Weights can be attached on the Center Plane of the Wheel.
- **Aluminum Alloy Balancing.** Balancing Wheels made of aluminum alloy. The Weights are placed differently on these Wheels. You will need to know where you want to put the Weights and select the appropriate ALU Mode. ALU Modes generally use Adhesive Weights, which are less visible than Clip-On Weights.

# Frequently Asked Questions

**Question:** What does a Wheel Balancer do?

**Answer:** The Wheel Balancer detects Wheel imbalances and indicates where on the Wheel and what value of counterweight is required to correct the Wheel imbalance. Wheel imbalance creates vibration which creates excessive wear on the Tires and steering components.

**Q:** Is Wheel Balancing the same as Wheel Alignment?

**A:** No. When you *balance* a Wheel, you fix a weight distribution problem that can cause Wheel wobble, uneven Tire wear, and Vehicle vibration. This is done by putting Weights on the Wheel in appropriate locations.

When you *align* a Wheel, you are adjusting the angles of the Wheel in relation to the Vehicle and the pavement. This reduces Tire wear and ensures the Vehicle drives straight and true (that is, the Vehicle does not pull to one side).

**Q:** Where can I put my Wheel Balancer?

**A:** This AB24M is designed to be mounted in three different configurations: stand-alone, wall mount or Tire Changer mount. Ideally, you want the Balancer away from high traffic areas, as you want to keep everyone away from the Balancer while it is in use. See [Installing the Balancer](#) for more information.

**Q:** Why are there two types of Weights?

**A:** Clip-On Weights are more visible. Adhesive Weights are lower profile and come in two colors so you can attempt to match the color of the Rim, so they are less visible. Some Vehicle owners prefer Adhesive Weights because they are less visible.

**Q:** Can the AB24M use 230 VAC power?

**A:** The AB24M is shipped ready for 115 VAC operation. The Balancer can be modified to operate on 230 VAC. For 230 VAC operation, you **must use a licensed Electrician** to wire the AB24M plug in accordance with applicable electrical codes. See [Connecting to Power](#) for more information.

## AB24M Dimensions

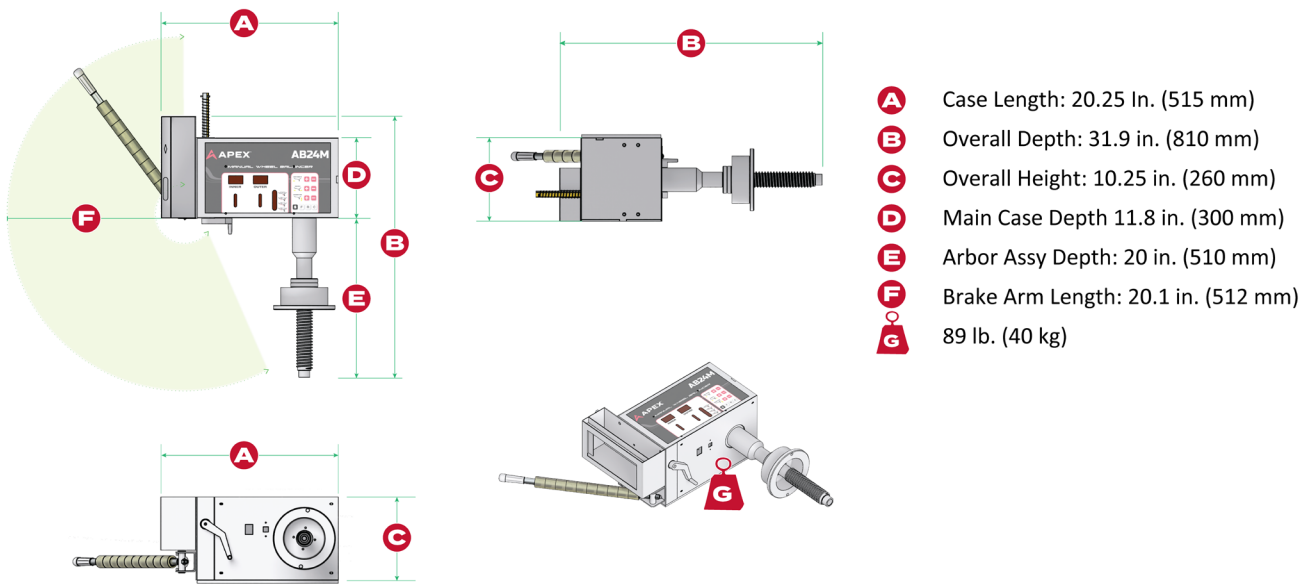

---

# Specifications - Model AB24M

<b>Specification</b>	<b>AB24M</b>
Power	115/230 VAC, 50/60 Hz, 1 Ph 15W
Balancing Modes	1 dynamic / 1 static / 3 aluminum alloy
Maximum Tire Diameter	31.5 in. (800 mm)
Maximum Tire Weight	143 lbs. (65 kg)
Max. Wheel Diameter	12 in. to 24 in. (305 mm to 610 mm)
Wheel Width Capacity	4 in. to 15 in. (102 mm to 381 mm)
Accuracy	± .035 oz. (1 gram)
Resolution	.25 oz. (5 grams)
Overall Width	31.9 in. (810 mm)
Length	20.25 in. (515 mm)
Height	10.25 in. (241 mm)
Weight	89 lbs. (40kg)
Power Cord Length	72 in. Min. (1,828 mm Min.)
Working Temperature	+32°F to +122°F (0°C to +50°C)
Storage and Transportation Temp.	+14°F to +140°F (-10°C to +60°C)
Relative Humidity (Non-Condensing)	20% to 95%

***Specifications are subject to change without notice.***

---

# Installation Checklist

Following are the steps needed to install an AB24M Wheel Balancer. Perform them in the order shown.

- 1. Review the installation Safety Rules.
- 2. Plan for Electrical Work.
- 3. Make sure you have the necessary Tools.
- 4. Select the Installation Site and mounting method. Tire Changer Mount, Mounting Stand, or Wall Bracket.
- 5. Verify that there is adequate Clearance on all Sides of the Balancer at the installation site.
- 6. Gather parts for installation, Mounting Stand (optional), Wall Mount Brackets (optional), or Tire Changer mount.
- 7. Unpack the Components.
- 8. Install the Balancer.
- 9. Anchor the Balancer.
- 10. Install the Shaft.
- 11. Connect to a Power Source, ***requires a licensed Electrician for 230 VAC operation.***
- 12. Review the Final Checklist.

---

# Installation

This section describes how to install your Balancer.

## Installation Safety Rules

**Pay attention at all times during installation.** Use appropriate tools and equipment. Stay clear of moving parts. Keep hands and fingers away from pinch points.

Use caution when unpacking the Balancer from its shipping container and setting it up. The Balancer is heavy and the weight is not evenly distributed; dropping or knocking over the unit may cause equipment damage or personal injury.

 **WARNING** You must wear appropriate protective clothing at all times during setup: leather gloves, non-skid steel-toed work boots, ANSI-approved eye protection, and an industrial back belt.

Only allow experienced, trained technicians to install the Balancer. In particular, all electrical work **must** be done by a licensed Electrician.

 **CAUTION** Certain parts of installing the Balancer are difficult for just one person. Two or more persons are required to install the Balancer.

If you have to use an extension cord, make sure its current rating is equal to or greater than that of the equipment being used. Make sure the extension cord cannot be stepped on, run over, or pulled out. Extension cords are a tripping hazard, so they must be secured.

## Plan for Electrical Work

The Balancer comes from the factory wired for 115 VAC power. You may convert the Balancer for use with 230 VAC power.

 **DANGER** All electrical work, such as attaching the Plug to the Power Cord for 230 VAC operation, **must be completed by a licensed Electrician** in accordance with all applicable electrical codes at your location.

## Tools

You may need some or all of the following tools:

- Small level for the optional wall mount bracket
- Hex key wrench set (three hex keys come with the unit: 6, 8, and 12 mm in the Accessories box)
- SAE and Metric wrench sets
- Adjustable wrench
- Scissors, utility knife, or other cutting tool
- Hammer
- Hammer Drill and masonry bit for anchoring

## Finding a Location

Keep in mind the following when deciding on a location:

- **Power source.** The Balancer needs to be near an appropriate 110 or 230 VAC power source.
- **Floor.** The Balancer is best used on a flat, concrete floor. If the floor is not level or is unstable, the Balancer will not return accurate test results.
- **Accessibility.** You need some space to move the Wheels you are going to balance to and from the Balancer. Do not set up the Balancer in a well-travelled area.
- **No water.** The Balancer has electronic components. If the Balancer gets wet while turned on, those electronic components will likely short circuit and have to be replaced.

**⚠ DANGER** Do not use the Balancer if it is sitting in water. You will almost certainly short circuit the electronic components in the Balancer and you could electrocute yourself.

**⚠ WARNING** When a Wheel is spinning on the Balancer, you need to keep people away from it. Do not touch the Rotating Wheel or Tire with your hand or body. Do not wear loose clothing that can be caught up in the Wheel. Serious injury may result.

## Clearances

For safety and to allow enough space to work with Wheels, a certain amount of clearance around the Balancer is recommended.

### Clearances

Required space around the AB24M Balancer for safe operation

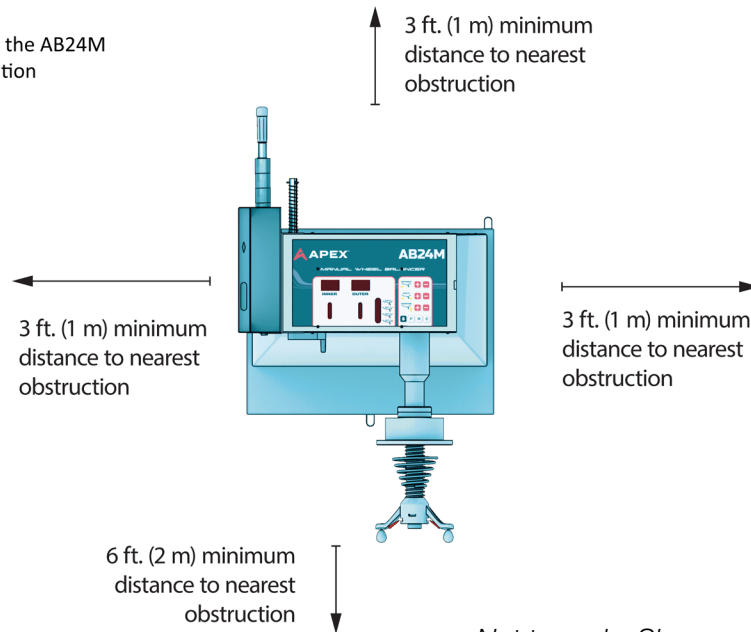

## Unpacking

Use caution when unpacking the Balancer from its shipping container. You do not want to damage the unit, misplace any of the components that come with it, or hurt anyone.

**⚠ CAUTION** Make sure to use an appropriate lifting device, such as a Forklift or pallet jack, to move the Balancer while it is on its pallet. Make sure only personnel who are experienced with material handling procedures are allowed to move the Balancer. The Balancer is heavy and the weight is not evenly distributed; dropping or knocking over the unit may cause equipment damage or personal injury. Do not lift the Balancer by the Shaft or its housing; it will damage the Balancer.

We recommend you unpack the Balancer in the area where you are going to set it up.

### To unpack the Balancer:

1. Remove the carton by flipping down the metal tabs at the bottom and pulling off the top.
2. Remove the shipping bolts that are holding the Balancer to the Pallet.

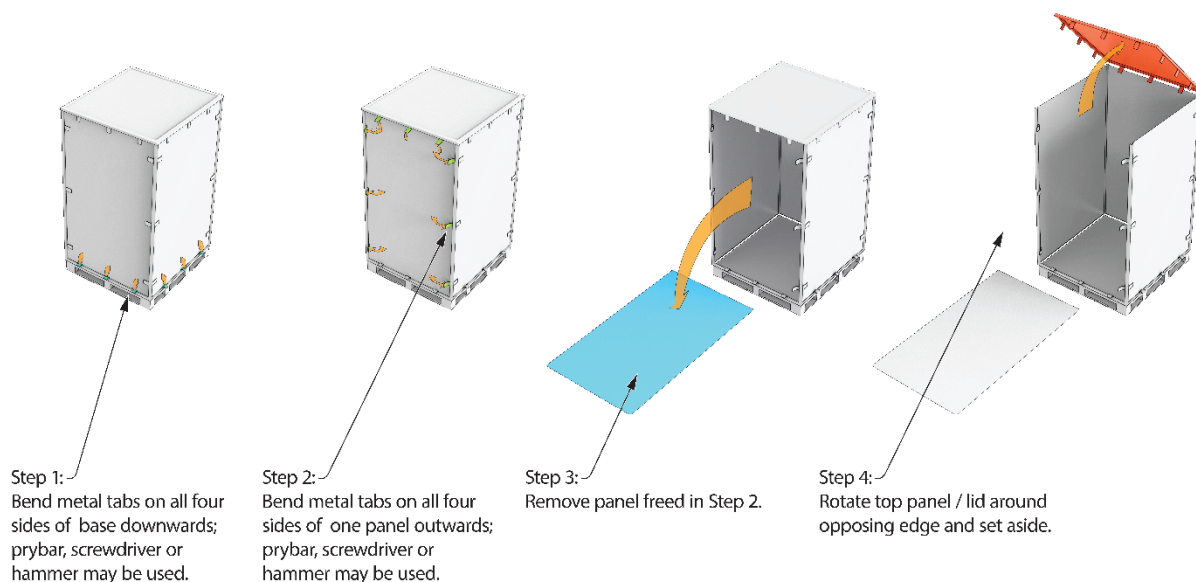

3. Remove the straps and plastic wrap that held the Balancer components during shipping.
4. Move the Balancer off the Pallet, then move it to the desired location.

**⚠ WARNING** Do not lift the Balancer by the Shaft; it is not strong enough to bear the weight of the Balancer.

**⚠ CAUTION** APEX requires having at least two people move the Balancer; it is heavy. If it is dropped or falls, it could cause injuries and/or the Balancer could be damaged.

### IMPORTANT



**NEVER** use the wheel balancer main shaft as a lifting, pulling, or handling point during unloading or installation. The main shaft is **directly coupled** to internal piezoelectric sensors.

Applying lifting or side loads to the shaft can **damage** these sensors, resulting in calibration failure, inaccurate balance readings, or permanent internal damage, and a **voided warranty**.

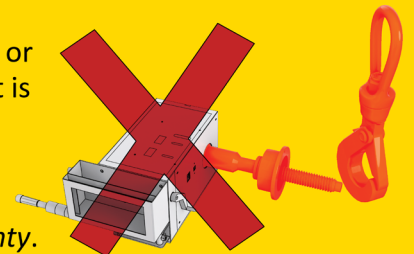

## Installing the AB24M on the Mounting Stand

An **optional** Mounting Stand is available for the AB24M . The AB24M Mounting Stand comes complete with all attaching hardware required to install the Balancer.

Refer to **illustration** on the following page.

### To install the Balancer on the Mounting Stand:

1. Remove the Recessed Cross Screws (3) from the Mounting Stand (5) and open the Cover (4).
2. Install the cone holders on the back side of the Mounting Stand.
3. Place the Balancer (1) on top of the Stand (5) and use four M10 Screws (2) to fasten the Balancer to the Mounting Stand.

**⚠ CAUTION** APEX requires having at least two people move the Balancer; it is heavy. If it is dropped or falls, it could cause injuries and/or the Balancer could be damaged.

4. Replace the Cover (4) and tighten the fasteners (3).
5. Move the Balancer to the desired location and match drill the holes for the Mounting Anchors.
6. Vacuum and brush the debris from the holes, then install the Anchors. Refer to **Anchoring the Balancer** for additional information.
7. Tighten the Anchors to prevent the Balancer from moving.

**⚠ CAUTION** The mounting must be rigid to prevent the Balancer from moving during the balancing operation. Inaccurate test results may be caused by a Balancer that moves during test.

### Mounting Stand

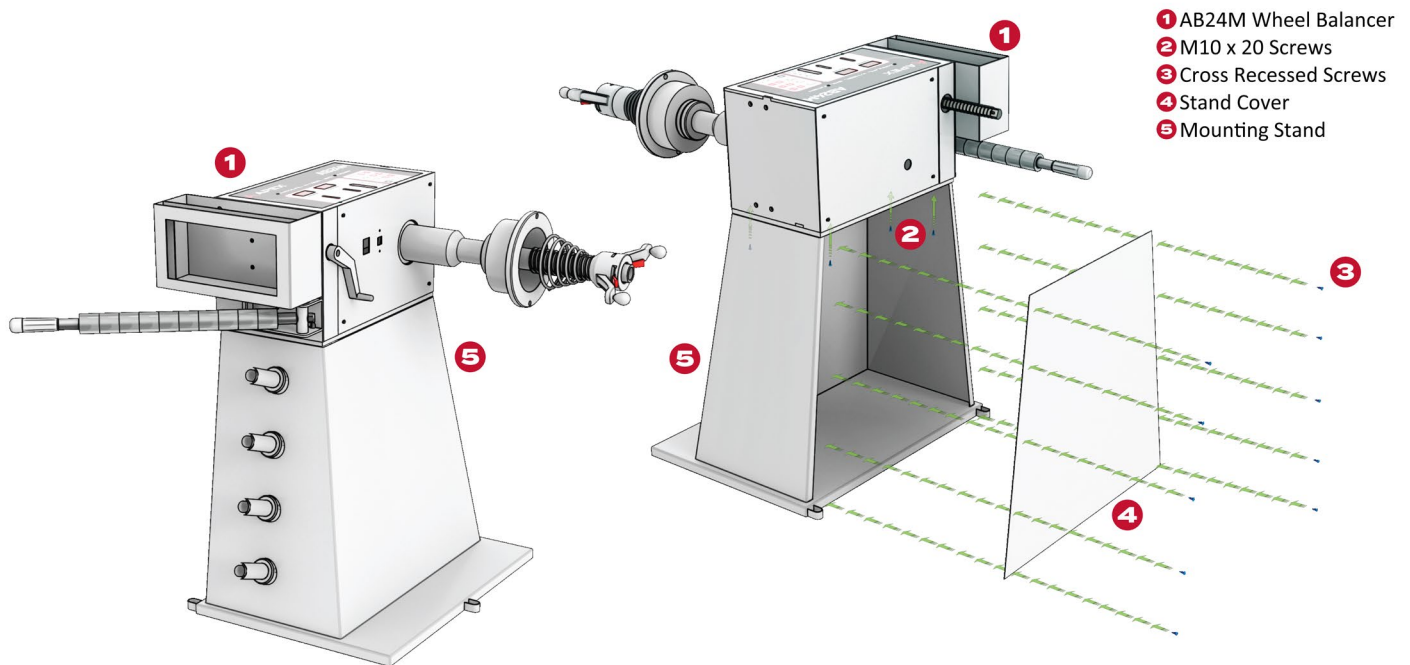

## Anchoring the Optional Balancer Mounting Stand

The optional Balancer Mounting Stand has three placement points for Anchor Bolts, which hold the Balancer in place while in use.

### Anchor Bolt Placement

Locations for anchor bolts for optional support

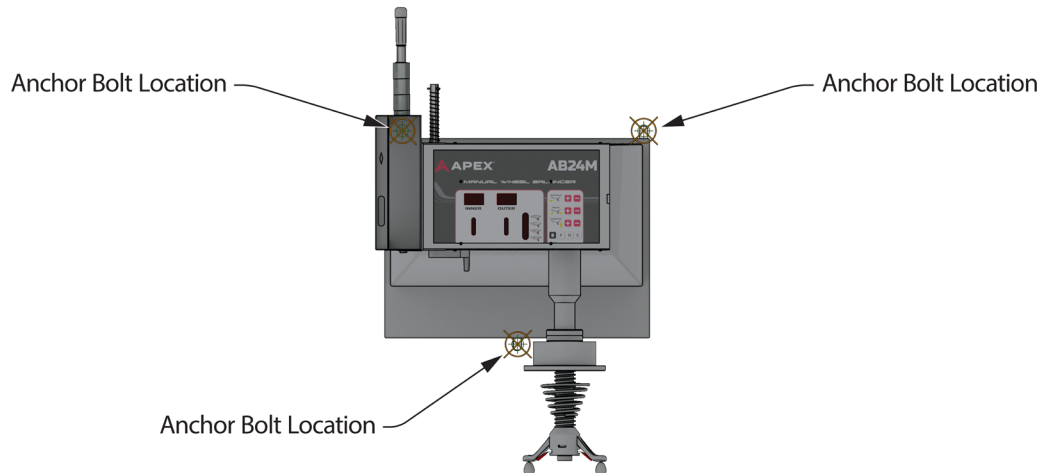

*Top View. Not to scale. Not all components shown.*

**Important:** You are **required** to bolt your Balancer into place, as Balancer movement during a Wheel Balance can result in inaccurate test results.

### To anchor the Balancer:

1. Move the Balancer to the desired location. Flat concrete provides the best mounting surface.  
Remember that you need to allow some space around the Balancer. Refer to [Finding a Location](#) for additional information.
2. Using the holes in the Mounting Stand as guides, drill the holes for the M10 x 59 mm Anchor Bolts.



Go in straight; do not let the drill wobble. Use a carbide bit (conforming to ANSI B212.15).

---

The diameter of the drill bit must be the same as the diameter of the Anchor Bolt. So if you are using an M10 diameter Anchor Bolt, for example, use an M10 diameter drill bit.

3. Vacuum each hole clean. APEX recommends using a vacuum to get the hole very clean.

**⚠ CAUTION** Wear appropriate eye protection.

Do **not** ream the hole. Do **not** make the hole any wider than the drill bit made it.

4. Make sure the Washer and Nut are in place, then insert the Anchor Bolt into the hole.

The Expansion Sleeve of the Anchor Bolt may prevent the Anchor Bolt from passing through the hole in the Base Plate; this is normal. Use a hammer or mallet to get the Expansion Sleeve through the Base Plate and into the hole.

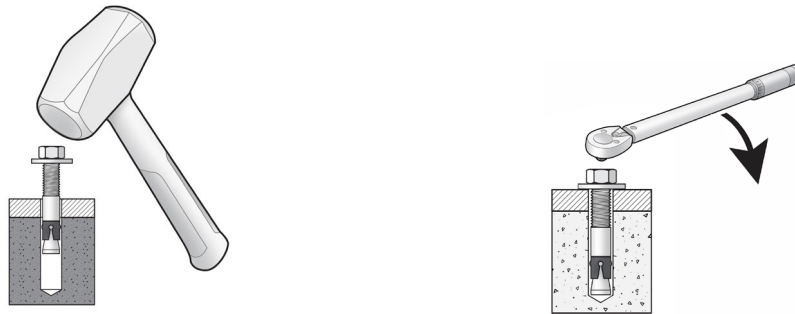

Even using a hammer or mallet, the Anchor Bolt should only go into the hole part of the way; this is normal. If the Anchor Bolt goes all the way in with little or no resistance, the hole is too wide.

Once past the hole in the Base Plate, the Anchor Bolt eventually stops going down into the hole as the Expansion Sleeve contacts the sides of the hole; this is normal.

5. Hammer or mallet the Anchor Bolt the rest of the way down into the hole. Stop when the Washer is snug against the Base Plate.
6. Wrench each Nut **clockwise** to the recommended torque of 55 lbf-ft./ 75 N-m. Wrenching the Nut forces the Wedge up, forcing out the Expansion Sleeve and pressing it tightly against the Concrete.

**Important:** Do **not** use an impact wrench to torque the Anchor Bolts.

## Installing the AB24M on the AT26/26A Tire Changer

The AB24M is shipped with a Weldment Base Assembly for installation on the APEX AT26 Series Tire Changer. The Base Assembly is a bolt-on addition to the AT26 Tire Changer allowing the Tire changing and balancing all in one location, saving space and time wasted in transporting the Tire from changing to balancing stations.

Refer to **Figure B** on the following page.

### To install the AB24M on the Tire Changer:

1. Install the Base Assembly Weldment on the Tire Changer using the Hex Screws, and Lock Washer provided.
2. Secure the Balancer on to the Weldment using the M10 Screws (item 7) included.
3. Attach the tooling holder mounting plate and cone hangers on the Weldment using the Screws provided.

## Mounting on Tire Changer

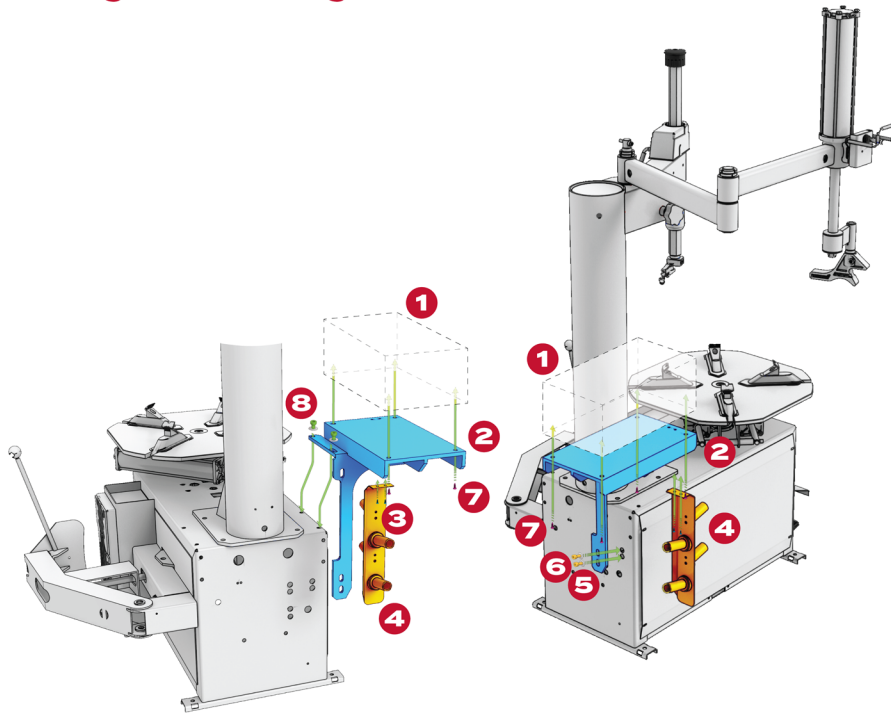

- 1 AB24M Wheel Balancer
- 2 Base Assembly
- 3 SHCS M6 x 30
- 4 Tool Hanger Mount
- 5 Lock Washer
- 6 M10 x 30 SCHS
- 7 M10 x 20 Screws
- 8 M10 x 65 SHCS

## Installing the AB24M Balancer on the Wall Bracket

The AB24M Wall Brackets are an optional mounting configuration. This configuration allows the Balancer to be mounted on a wall, consuming a minimum of floor space.

### To install the AB24M on the Wall Bracket:

Refer to **Figure C** on the following page.

1. The location should be away from pedestrian traffic.
2. The location **must be no less than 22 in. (560 mm) off the ground** and allow for easy movement of Wheels and Tires around the Balancer without causing a hazard to personnel.

**⚠ DANGER** Consult a qualified, licensed contractor to wall mount the AB24M. Only wall mount the AB24M on a core-filled masonry block, or a reinforced concrete wall. The wall must be capable of supporting the weight of the AB24M, the Wheel and the Tire. This combined weight can exceed 225 lbs. (102 kg). Anchors in drywall **will not** support this Balancer and Wheel. Serious injury can result from the Balancer tearing away from a drywall mount.



**Tip**

The Wall and mounting must be rigid enough to prevent the Balancer from moving during balancing. Inaccurate readings can result from a Balancer that moves during test.

3. Assemble the Wall Brackets (2)(3)(4)(5)(6).
4. APEX strongly recommends having a second person help install the Balancer on the wall mount bracket.
5. Locate the Bracket on a wall rated to accept **>225 lbs. (102 kg)**.
6. Refer to the figure below for Anchor Hole locations. Mark the Anchor Hole locations on the wall.

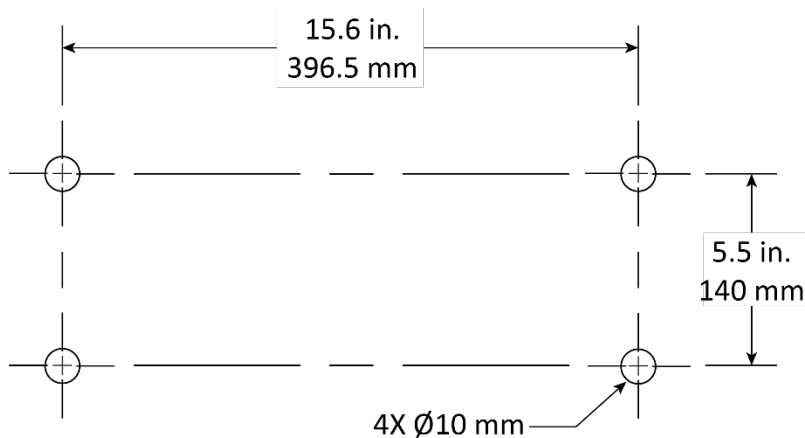

Front View. Not to Scale.

7. If this is a reinforced concrete or core-filled block wall, use an appropriate masonry drill bit. Use a 10 mm drill for a 10 mm anchor. Refer to **Anchoring the Balancer** for additional information.
8. Clean the debris from the drill hole using a vacuum and brush.
9. Install the Anchors (12) in the Wall Mount Brackets with Washers and Nuts (7)(8).
10. Place the Anchors with the bracket on the wall and hammer or mallet the Anchors into the drilled holes.

11. Tighten the Nuts finger tight.
12. Using a small level to verify the brackets are level, you may lightly tap the bracket to correct any out of level condition. You may have to loosen the Nuts slightly. Once the bracket is straight and level re-tighten the Nuts on the Anchors.

**Important** APEX strongly recommends having a second person help install the Balancer on the bracket.

13. Attach the Balancer (1) on the wall mounting brackets using M10 Screws (11).
14. Attach the Cone Tooling Bracket (9) on the front right side of the assembly, using the Screws supplied.

## Mounting on Wall Brackets

**Only** wall mount the AB-24M on a core-filled masonry block, or a reinforced concrete wall.

The wall **must be capable** of supporting the weight of the AB-24M, the Wheel and the Tire.

This combined weight can exceed 225 lbs. / 102 kg.



Anchors in drywall **will not** support this Balancer and Wheel.

**Serious injury** can result from the Balancer tearing away from a drywall mount.

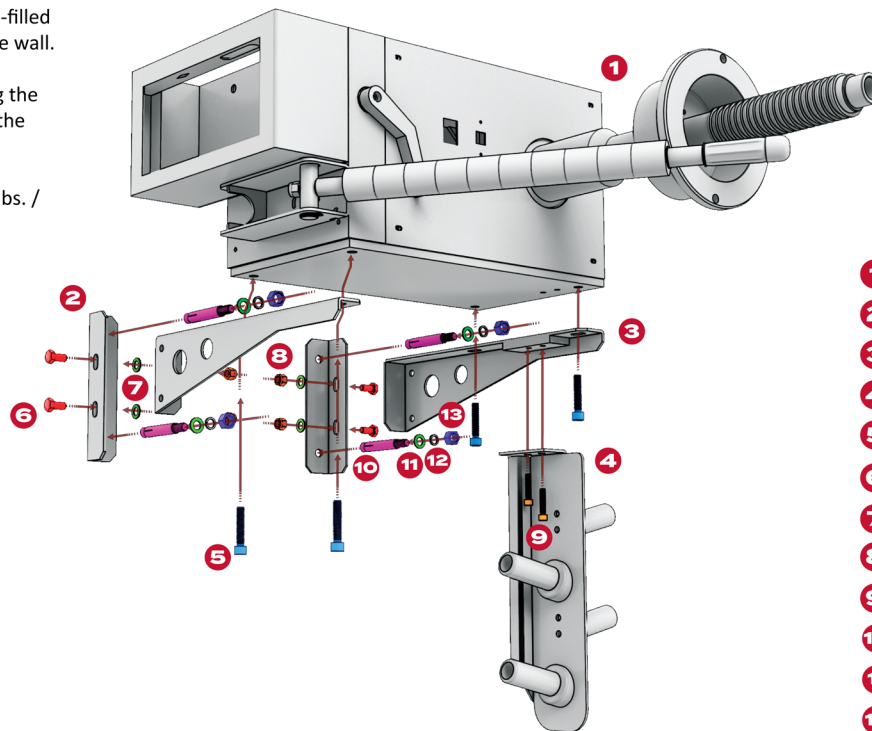

- 1 AB24M Wheel Balancer
- 2 Vertical Wall Bracket
- 3 Horizontal Support
- 4 Tool Hanger Mount
- 5 M10 Screws
- 6 Bolt
- 7 Washer
- 8 Nut
- 9 Screw
- 10 Anchor
- 11 Flat Washer
- 12 Lock Washer
- 13 Nut

## Installing the Shaft

The Shaft holds the Wheels to be balanced.

**⚠ CAUTION** The Balancer is awkward to hold and heavy. Two people are **required** to install the Shaft: one person to hold the Shaft Assembly in place while the second person Screws in the Mounting Bolt. Also, consider having some rags nearby as the Shaft is greased to protect it.

### To install the Shaft:

1. Locate the Shaft Assembly and the M14 x 240 mm SCHS Mounting Bolt from the parts supplied with the Balancer.
2. **Carefully** clean the threaded shaft and the center hole of the housing using alcohol or equal.
3. Have a second person hold the shaft housing while you put the Shaft Assembly into place next to the housing and hold it there.
4. Put the M14 x 240 mm SCHS Mounting Bolt into the end of the Threaded Shaft and *begin* tightening it with a 10 mm hex key.

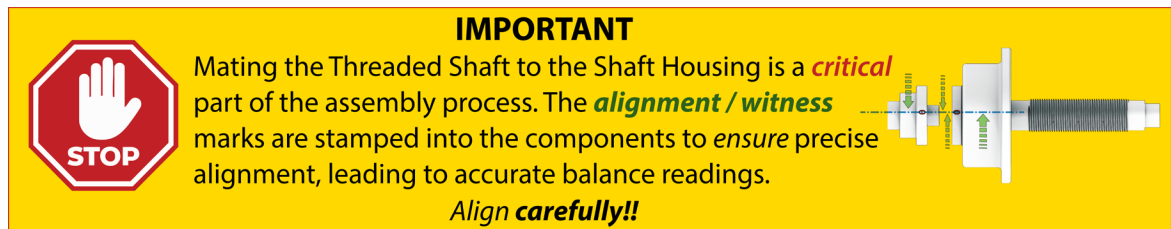

5. **Before fully tightening** the Mounting Bolt, make sure the Alignment Marks are aligned (see drawing below).

### Shaft installation

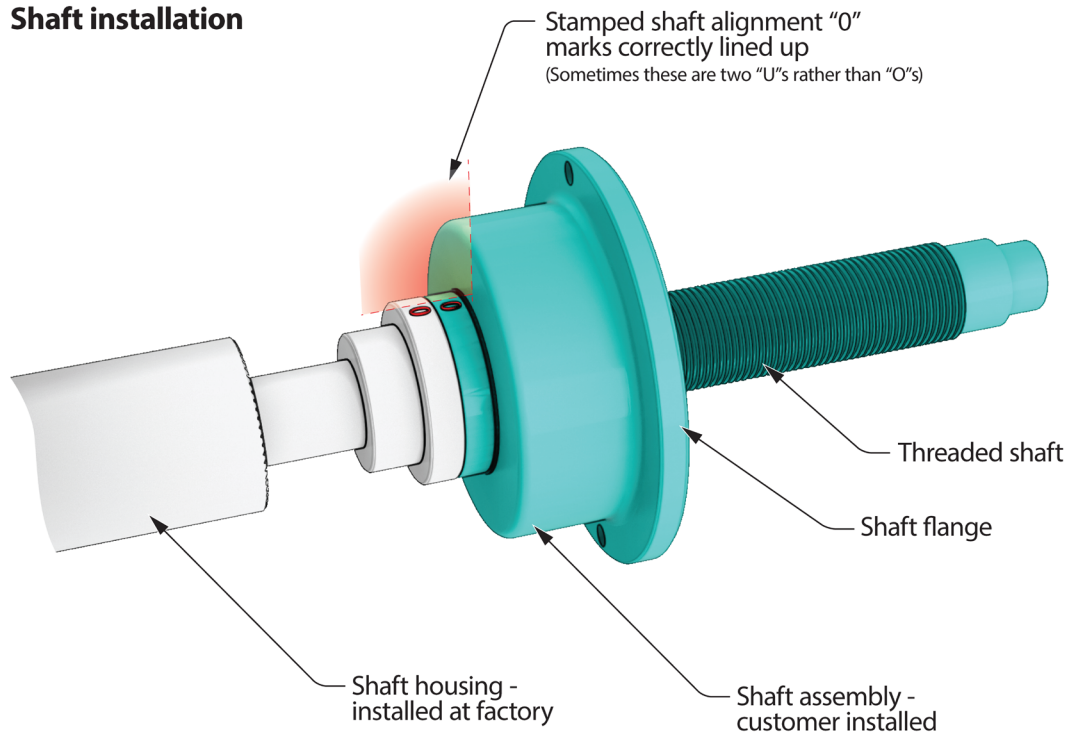

6. Tighten the Mounting Bolt into place.

## Connecting to Power

The AB24M Wheel Balancer is shipped with a 115 VAC plug and power cord. The Balancer may be configured for single phase operation at 230 VAC but will require a licensed Electrician to set the input Voltage Switch and wire the plug on the Balancer's power cord or to connect it directly to the facilities' power system through an appropriate fuse or circuit breaker.

**⚠ DANGER** All electrical work **must** be completed by a licensed Electrician. If you do not use a licensed Electrician, you void your warranty and put everyone who uses the Wheel Balancing Machine in danger of injury or, in rare cases, death. All Electrical work must be in accordance with national, state and local electrical codes.

**⚠ DANGER** This Wheel Balancing Machine uses electrical energy. If your organization has Lockout/Tag-out policies, implement them once the unit is connected to power.

Verify the Wheel Balancing Machine is **disconnected from the power source**.

If the Balancer is connected, disconnect it and Lock / Tag Out the machine and verify it cannot be re-energized until the electrical work is complete. **Do not begin to work on the Wheel Balancing Machine until you are sure that power has been disconnected from the unit.**

**Voltage Selector Switch Setting.** The Voltage Selector Switch (next to the on-off rocker switch) is to be set to the input Voltage **115V** or **230V** setting. Refer to illustration below.

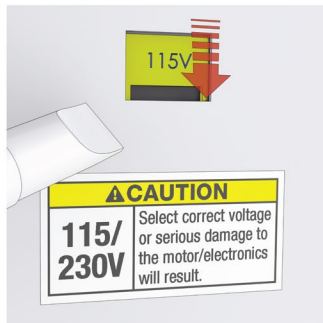

115 VAC Position

Use finger or screwdriver to slide switch up or down, selecting correct voltage for operation based on plug and final wiring completed by electrician.

The voltage selected will be clearly visible in the switch window once the slider has reached the endstop position for that voltage.

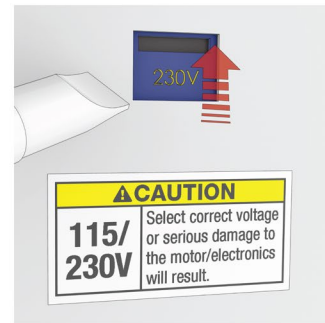

230 VAC Position

### To connect to 115 VAC:

1. Your AB24M comes with a three prong 115V plug already attached, verify the voltage selector is set to 115.
  - If the selector switch is set 115 you may use any 115VAC, 60 Hz. 1 Ph. wall outlet.
  - If the selector switch is set to 230 move the selector to 115 using your finger or a screwdriver, then plug into any 115 VAC wall outlet.
2. Double check the Voltage Selector Switch to make sure it is set to the **115V** setting.

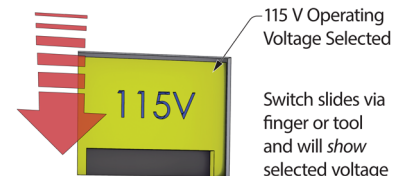

**⚠ CAUTION** The Voltage Selector Switch **must** match the power source. If you plug the unit in to 115 VAC power when the Switch is set to 230V or you plug the unit in to 230 VAC power when the Switch is set to 115V, you void your warranty and you could severely damage the Tire Changer.

3. Plug in the Tire Changer to a 115 VAC outlet.
4. Test the unit to make sure it is working normally.

**To connect to 230 VAC:**

**⚠ DANGER** This Wheel Balancing Machine uses electrical energy. If your organization has Lockout/Tag-out policies, implement them once the unit is connected to power.

1. Have a **licensed Electrician** attach a 250 VAC NEMA 30A, 2-Pole, 3-Wire plug. The AB24M does not provide this plug. You must supply your own. **Do not connect the 230 VAC plug unless you are a licensed Electrician.**

The colors of the three exposed wires from the power cord are Brown, Blue, and Green/Yellow, the European color code.

**Brown:** Live

**Blue:** Live

**Green/Yellow:** Ground

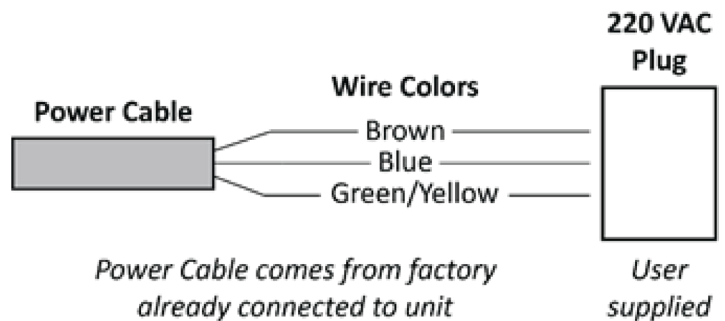

2. Double check the Voltage Selector Switch to make sure it is set to **230V**.

This can be done using either your finger or a slot screwdriver.

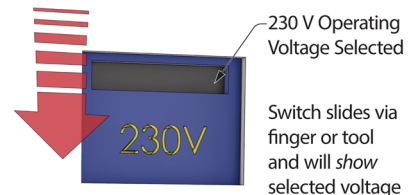

**⚠ CAUTION** The Voltage Selector Switch **must** match the power source. If you plug the unit in to 115 VAC power when the Switch is set to 230V or you plug the unit in to 230 VAC power when the Switch is set to 115V, you void your warranty and you could severely damage the Tire Changer.

3. Plug in the Tire Changer to a 230 VAC outlet.
4. Test the unit to make sure it is working normally.

Additional electrical information:

- **You must ground the Tire Changer.**
- Damage caused by improper electrical installation (such as not grounding the unit) voids the warranty.

**⚠ WARNING** Disconnect power **before** performing **any** troubleshooting or maintenance. Make sure the unit cannot be re-energized until you are done. This equipment has internal arcing or sparking parts that should not be exposed to flammable vapors. The unit **must not** be located in a recessed area or below floor level.

---

 **WARNING**

**For generator users and or areas with frequent brown-out**

**conditions.** Premature component failure due to excessive high or low voltage is **not** covered under warranty. Verify that the power supply can provide the required current and voltage. While voltage variations are common ( $\pm 5\%$ ) both high and low voltage episodes in excess of 15% to 20% can cause premature electrical and electronic component failure.

## **Final Checklist Before Operation**

Make sure these things have been done **before** using your Balancer:

- Review the Installation Checklist to make sure all steps have been performed.
- Make sure the Balancer is getting power from the power source.
- Check to see that all Anchor Bolts are in position and tightened.
- Leave the Manual with the owner/operator.

# Operation

This section describes how to use your AB24M Wheel Balancer.

## About the AB24M Wheel Balancer

The AB24M has no motor to drive the Tire and Wheel. Instead, the Wheel is rotated by hand-spinning the Quick Nut. The black handles of the Quick Nut rotate freely and will allow you to easily develop the speed ( $\approx 180$  rpm) required to balance the Wheel.

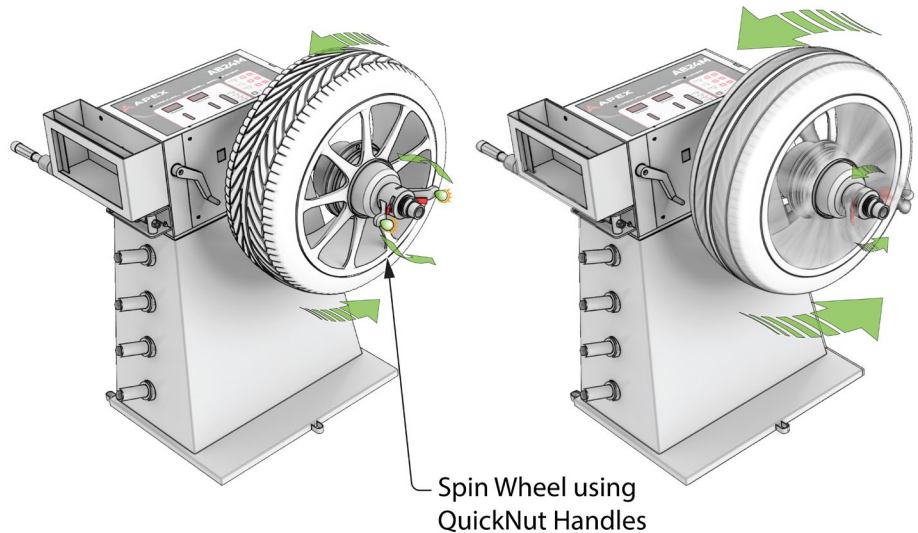

## Usage Precautions

Keep the following in mind while you operate your Balancer:

- Make a visual inspection of the balancer **before each use**. Do not operate your Balancer if you find any issues. Instead, take the unit out of service, then contact your dealer, visit [APEX.com/support](http://APEX.com/support), or call **(877) 432-6627**.
- Keep the work area clean and well lit. Dirty, cluttered, and dark work areas increase the chances of an accident happening.
- Do not remove the Storage Tray unless instructed to do so by APEX Support. There are no user serviceable parts underneath.
- When using the product, you **must** wear appropriate work clothing: leather gloves, non-skid steel-toed work boots, and an industrial back belt. Keep hair, jewelry, and clothing away from the unit.
- When using the product, **the operator must wear ANSI-approved eye protection at all times**: safety glasses, a face shield, or protective goggles.

**⚠ WARNING** Always wear ANSI-approved eye protection. Although rare, an accident could cause significant injuries to your eyes.

**⚠ WARNING** Do **not** attempt to stop a rotating Wheel with your hands. Always use the brake. Even though there is no motor driving the Wheel, it can severely injure you if it is in motion.

- Only authorized personnel may use the unit. Keep children and untrained personnel away.
- Do not use the unit in a wet environment or expose it to rain.
- If an extension cord is necessary, a cord with a current rating equal to or more than that of the equipment must be used. Cords rated for less current than the equipment may overheat. Care should be taken to arrange the cord so that it will not be tripped over or pulled.
- Do not use the unit in the vicinity of open containers of flammable liquids.
- Clean the unit according to the instructions in the **Maintenance** section.
- Read the entire *Installation and Operation Manual* before using the Wheel Balancer.

## Viewing/Entering Information on the Display and Control Panel

The Display and Control Panel allows you to enter information about the Wheel you are balancing and display the test results.

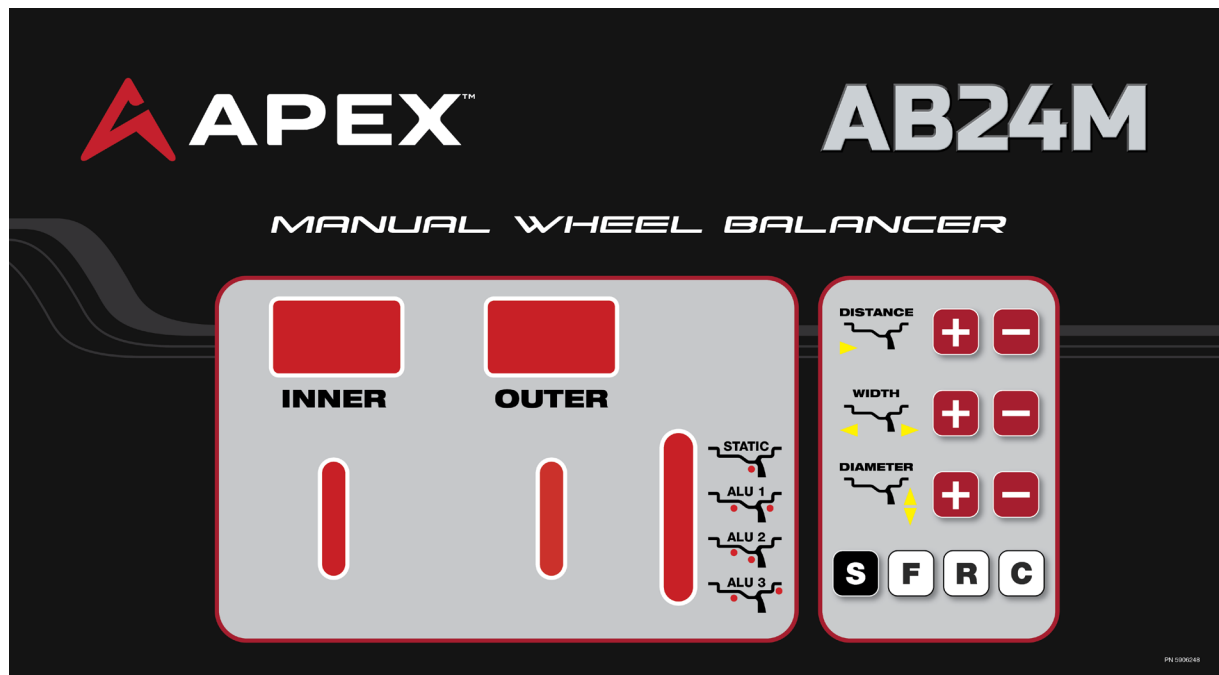

The parts of the Display Panel include:

- **INNER Display Window.** Displays test results and the Wheel parameter to be entered using the **+ / -** keys. Value is displayed in the **Outer Display Window.**

Parameters displayed include:

- **A - Inside Distance** – the distance from the side of the Balancer to the inner edge of the Wheel (measured by the Inner Arm) and manually entered.
- **L - Wheel Width** – measured using the Wheel Caliper and manually entered.
- **D - Wheel Diameter** - read off the Tire sidewall and manually entered.
- **OUTER Display Window.** Displays test results and during the Measurements phase, this Window Displays:
  - **Inside Distance (A)** - the distance from the edge of the Balancer to the inner edge/plane or center plane of the Wheel (measured by the Inner Arm) and manually entered.
  - **Wheel Width (L)** - measured using the Wheel Caliper and manually entered.
  - **Wheel Diameter (D)** - read off the Tire side wall and manually entered.
  - During the test and Weights phase, it displays the weight to be added to the outer plane of the Wheel.
- **Placement Indicators under the INNER Display Window.** When Weight needs to be added to a Wheel, you turn the Wheel slowly and watch the indicators under the inner display window. When all of the indicators are lit, hold the Wheel in place using the brake. Place the correction weight at 12 o'clock dead center on the Inner Edge/Plane of the Wheel.
- **Placement Indicators under the OUTER Display Window.** When Weight needs to be added to a Wheel, slowly turn the Wheel and watch the indicators under the Outer Display

Window. When all of the indicators are lit, hold the Wheel in place using the brake. Place the correction weight at 12 o'clock dead center on the outer edge/plane of the Wheel.

- **Balancing Mode indicators.** Select the Balancing mode by pushing the **F** key. The indicator will light next to the balancing mode selected. Modes available are **Dynamic, Static, ALU 1, ALU 2, and ALU 3.** The red marks indicate the position plane for the correction weight.

Available weight locations:

**⚠ CAUTION** Never use tools or anything sharp to press the keys on the Balancer. Damage to the switch and display membrane will occur.

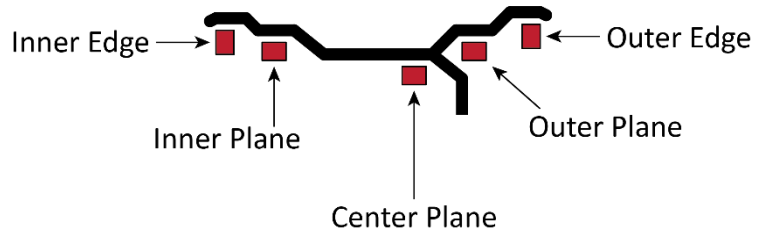

- **Distance. -A-** is displayed in the **Inner Display Window.** Used to enter the inside distance between the side of the Balancer and the inside edge/plane of the Wheel. Value is displayed in the Outer Display Window. Press **+** and **-** to increase and decrease the value.
- **Width. -B-** is displayed in the **Inner Display Window.** Used to manually enter the Width of the Wheel. Press **+** and **-** to increase and decrease the value. This value is displayed in the **Outer Display Window** and is measured by the Wheel Caliper supplied with the Balancer.
- **Diameter. -A-** is displayed in the **Inner Display Window.** Used to manually enter the **Diameter** of the Wheel. Press **+** and **-** to increase and decrease the value. This value is displayed in the **Outer Display Window** and is read off the Tire sidewall.
- **S Key.** Combination Function Key.
- **F Key.** Selects balancing modes.
- **R Key.** Combination function and reset key. Push once to revise distance, width or diameter inputs.
- **C Key.** Displays imbalances of <5g.

**Combination key inputs:**

<b>S + R keys</b>	Resets the Balancer to run the same test mode using the same Wheel data again.
<b>S + F keys</b>	Displays the last completed test and balance mode.
<b>S + F keys</b>	Hold the keys down until the Wheel position indicators stop flashing (about 5 seconds) then release.
<b>S + (Distance +) + (Distance -)</b>	Shifts weight units between grams / ounces.

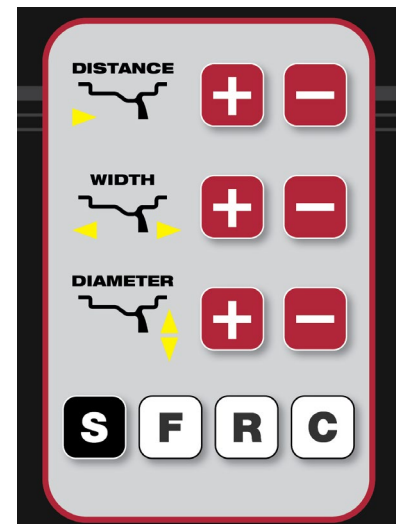

## About Wheel Planes

If you were to split a Wheel down the center (as shown below), it would be split into two “Planes”, an Inner Plane and an Outer Plane.

Balancing a Wheel on **both** planes at the same time is the most effective method. Of the five Balancing Modes supported by the AB24M , four of them balance on two planes at the same time.

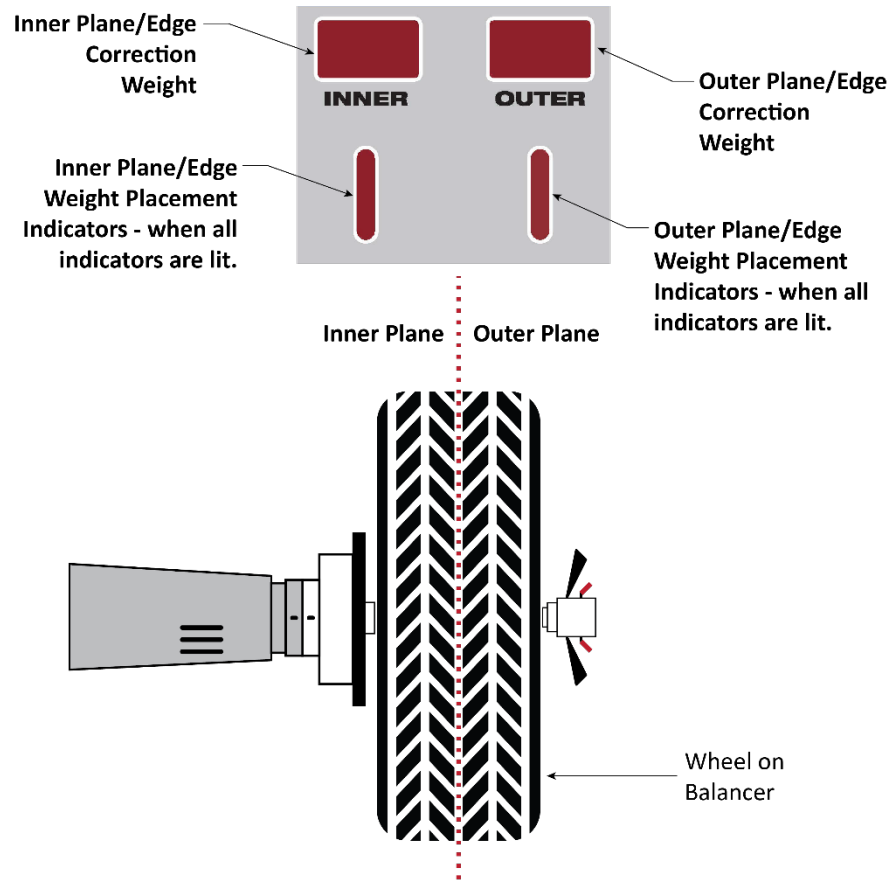

The fifth mode, **Static (STA) Mode**, is included for older, thin, Automobile Wheels and Motorcycle Wheels, which are not big enough to be balanced on both planes at the same time.

Because balancing a Wheel on both planes is so important to using the AB24M , the Display Panel shows a two-plane view of the Wheel being balanced.

The Inner Plane is the Tire side closest to the Balancer (the side of the Tire closest to the Vehicle) and the Outer Plane is on the right (the side of the Tire furthest away from the Vehicle.)

The **INNER** Window will display the correction weight to be place on either the Inner Edge or the Inner Plane weight locations.

The **OUTER** Window shows how much weight to place on either the Outer Edge or the Outer Plane weight locations.

The weight placement Indicators, directly under the Inner and Outer Display Windows, all light up when the best weight location is reached.

## About Measurements

To balance a Wheel correctly there are three Wheel measurements that are important to understand:

- **Distance.** The distance from the side of the Balancer to the Inner Edge of the Wheel. Measured by the Inner Arm.
- **Width.** The distance from the Inner Edge of the Wheel to the Outer Edge. This value is measured and read off the Wheel caliper supplied with the Balancer.
- **Diameter.** The distance from Wheel's Outer Edge to Outer Edge through the center. This value is read off the Tire side wall.

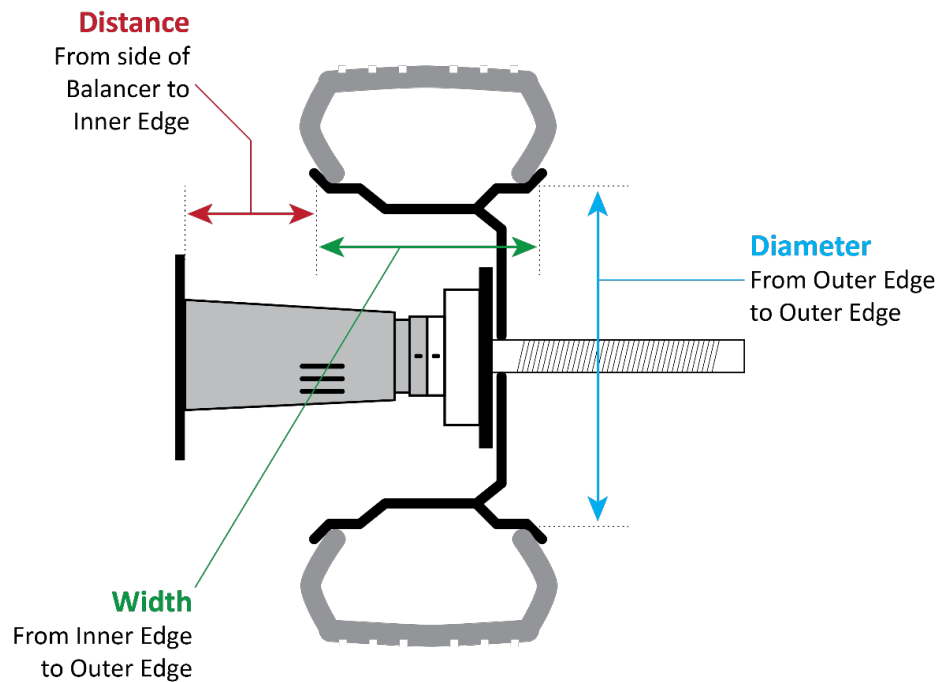

**Measure**  
From side of  
Balancer to  
Inner Edge

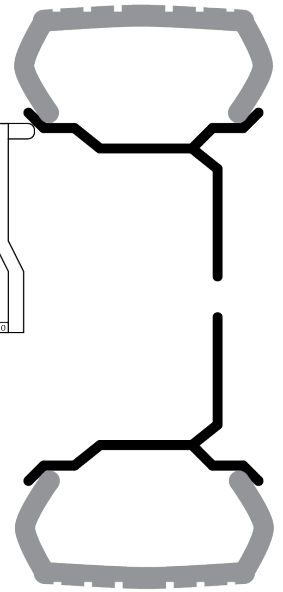
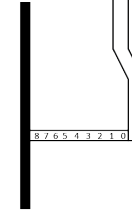

## Inputting Measurement Data

- **Distance.** Pull out the Inner Measuring Arm until it touches the inner Wheel rim, note the value on the Distance Ruler, and enter that value using the **Distance +** and **-** buttons on the Control Panel.  
An **-A-** will appear in the Inner Display Window and the current value in the Outer Window.
- **Width.** Measure with the Wheel Calipers, then enter that value using the Width **+** and **-** buttons on the Control Panel.  
An **-L-** will appear in the Inner window and the current value in the Outer Window.
- **Diameter.** Read the value from the Tire sidewall, then enter that value using the **Diameter +** and **-** buttons on the Control Panel.  
A **-D-** will appear in the Inner window and the current value in the Outer Window.

## Mounting a Wheel

The first step to balancing a Wheel is to mount it on the Shaft.

**Important:** All Wheels should be mounted so that the inside (the side of the Wheel that goes closest to the Vehicle) goes on the Shaft first.

There are three methods to mount a Wheel onto the Shaft:

- **Front-Cone Mounting.** The preferred method, as it generally produces the most accurate balancing results. Refer to **Figure E** below.

An appropriately sized Mounting Cone goes on the Shaft after the Wheel, then the Quick Nut.

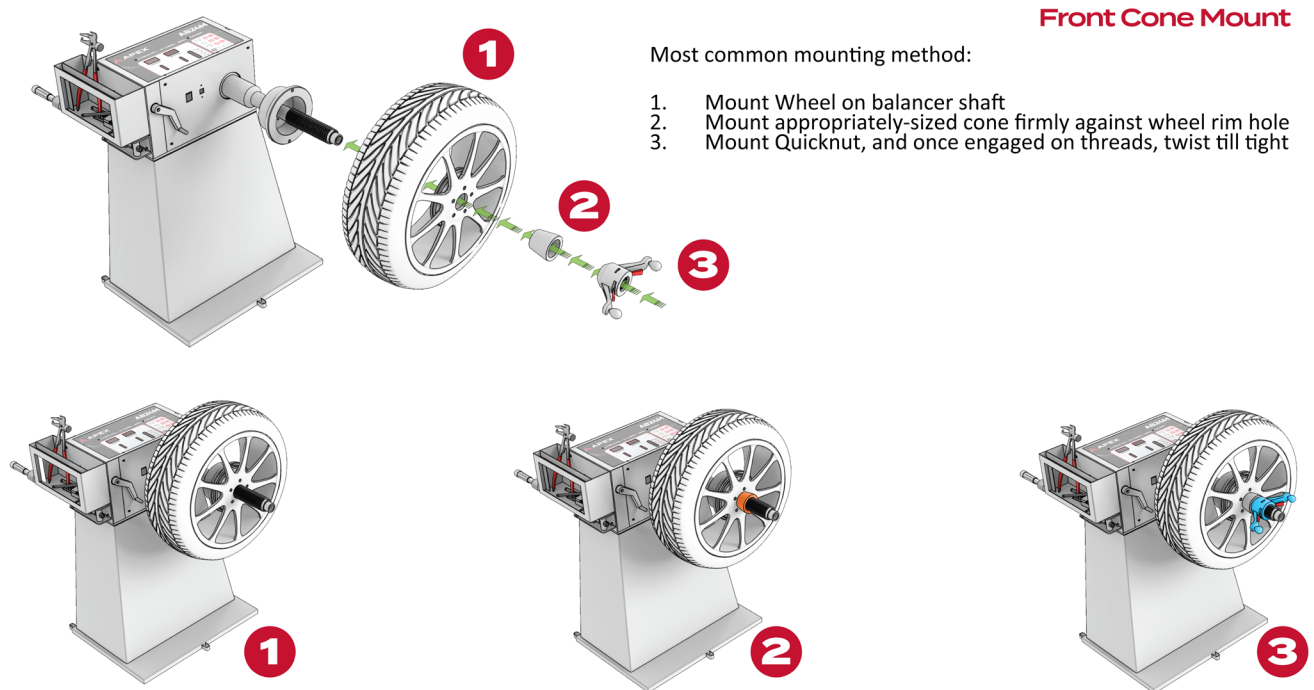

- **Rear-Cone Mounting.** Use this method if the Wheel you are balancing cannot be mounted with Front-Cone Mounting. Refer to **Figure F** below.

The Spring goes on the Shaft first, then an appropriately sized Cone, the Wheel, the Quick Nut Cup, and finally the Quick Nut.

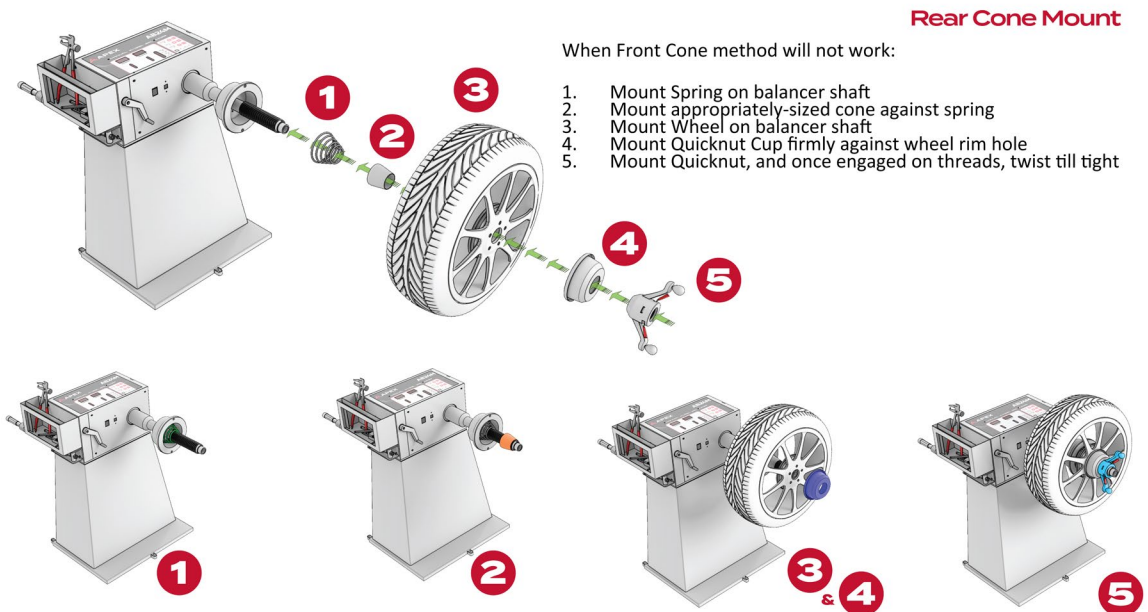

- **Dual-Cone Mounting.** Generally used only for some aftermarket or OEM performance Wheels that have a center hole that is deep enough to allow the use of two cones on the Shaft. Refer to **Figure G** below.

The Spring goes on the Shaft first, then an appropriately sized Cone, the Wheel, a second appropriately sized Cone, and finally the Quick Nut.

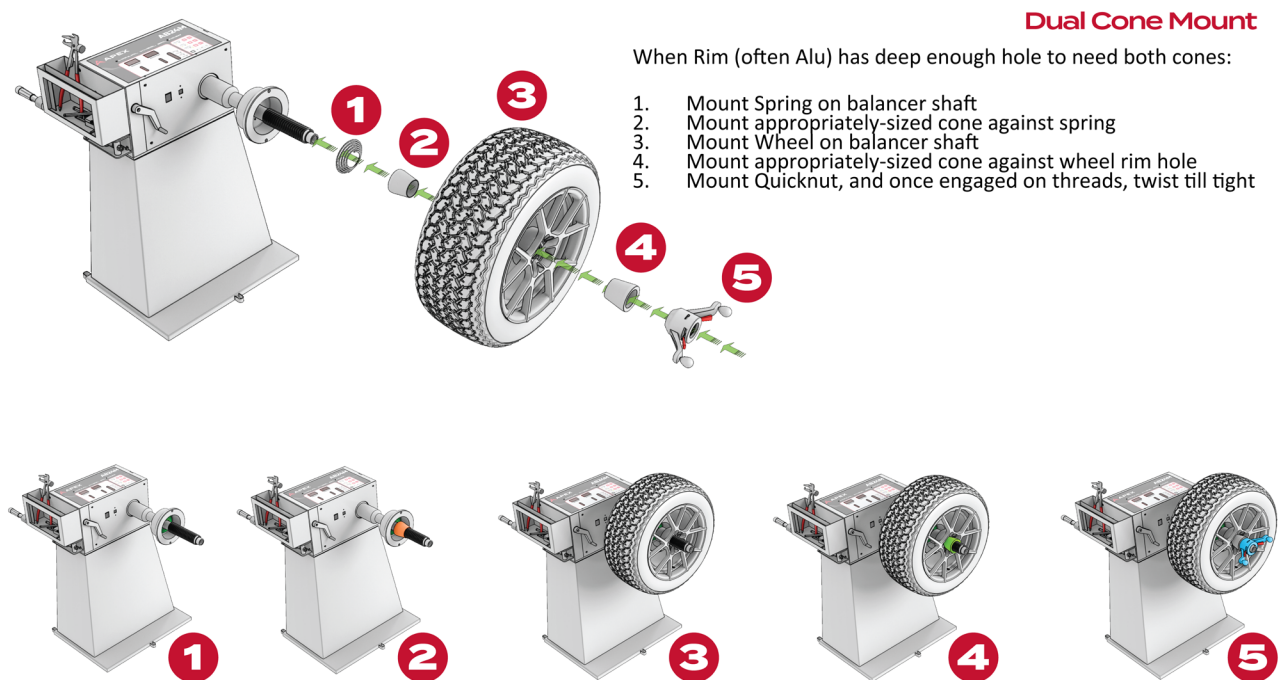

---

## To mount a Wheel:

1. Make sure you are wearing ANSI-approved eye protection: safety glasses, face shield, or goggles.
2. Determine which mounting method you want to use.
3. Move the Wheel you are going to mount next to the Shaft.
4. Select the Mounting Cone that best fits the center hole of the Wheel.
5. If Rear-Cone or Dual-Cone Mounting, put the Spring and the desired Cone onto the Shaft.
6. Lift the Wheel and put it onto the Shaft, then slide it back towards the Shaft Flange.

You may need to lift the Wheel slightly when positioning a Cone in the center hole of the Wheel.

7. While holding the Wheel and other hardware in place, slide the Quick Nut over the Shaft while holding the Red Quick-Release Levers next to the Wings.

Holding the Quick-Release Levers next to the Wings lets you Quickly slide the Quick Nut into position near the Wheel.

8. Release the Quick-Release Levers.
9. Turn the Wings to fully tighten the Quick Nut, and thus the Wheel, in place.

You may want to spin the Wheel some as you tighten the Quick Nut; this can help you get a strong, secure fit.

**Important:** Do not hammer or hit the Quick Nut to tighten it. You will damage the Quick Nut, which is **not** covered under the Warranty.

## Balancing Modes

Balancing Modes are based on the locations where the weight is applied:

- **Dynamic (DYN).** The default Balancing Mode when power is first applied to the Balancer. Typically used with steel rims. If the Wheel is out of balance, weights are clamped on the Inner and Outer Edges.

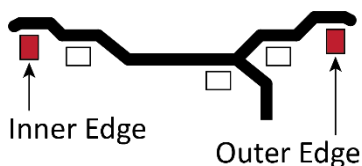

- **Static (STA).** Used for older Wheels under 4 inches wide and motorcycle Wheels. Weight is applied to the Center Plane only.

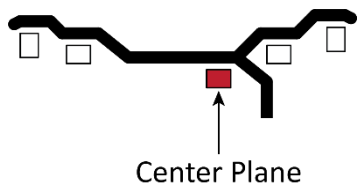

- **Aluminum 1 (ALU1).** Used on Aluminum Alloy Wheels. Weight is to be applied to the Inner Plane and the Outer Plane.

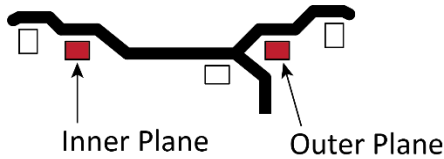

- **Aluminum 2 (ALU2).** Used on Aluminum Alloy Wheels. Weight is to be applied on the Inner Plane and the Center Plane.

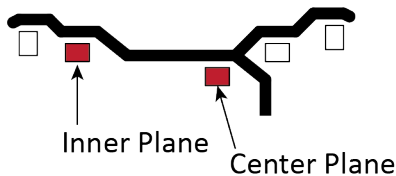

- **Aluminum 3 (ALU3).** Used on Aluminum Alloy Wheels. Weight is to be applied on the Inner Plane and clamped to the Outer Edge.

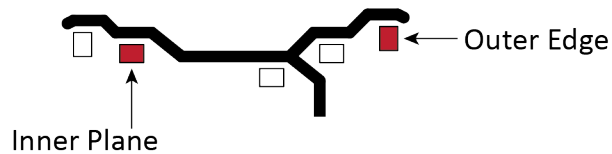

## Before You Balance a Wheel

Before you balance a Wheel, you should:

- **Remove all existing Weights from the Wheel.** If the Wheel already has Weights on it, either Clip-On or Adhesive, take them off. They will throw off the new balancing process.
- **Thoroughly clean the Wheel.** Mud or dirt on the Wheel will impact the new balancing process. If you install Adhesive Weights, they must be placed on to a clean surface (so they are less likely to fall off).
- **Put on appropriate eye protection and safety gear.** Do not use the Balancer unless you are wearing ANSI-approved eye protection: safety glasses, a face shield, or protective goggles.
- **Make sure the area is clear.** Only the operator should be near (within 30 feet) of the Wheel Balancer while the Wheel is turning.
- **You must wear OSHA-approved (publication 3151) Personal Protective Equipment** at all times when installing, using, maintaining, or repairing the Wheel Balancing Machine. Leather gloves, steel-toed work boots, eye protection, back belts, and hearing protection *are mandatory.*

**⚠ WARNING** Do *not* attempt to stop a rotating Wheel with your hands. Always use the brake. Even though there is no motor driving the Wheel it can severely injure you if it is in motion.

**⚠ CAUTION** Wheels and Tires can be heavy. Be aware of your own safety. Lift carefully, and if the Wheel is too heavy request assistance mounting and de-mounting the Wheel.

---

**⚠ CAUTION** Do not strike or drop Wheels onto Balancer the main shaft. Damage to the balance sensors can result.

## Dynamic Balancing

Upon first applying power to the Balancer the default balancing mode is the Dynamic mode. No balance mode indicators are lit.

Dynamic Balancing balances a Wheel on both the Inner and Outer Edges.

If the Wheel is out of balance, a Clip-On Weight can be installed on either the Inner Edge, the Outer Edge, or both.

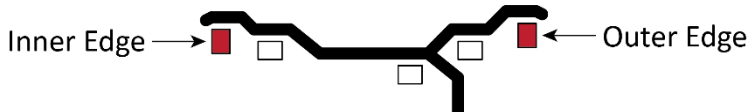

### To Balance a Wheel using Dynamic Mode:

1. Make sure you are wearing ANSI-approved eye protection: safety glasses, face shield, or goggles.
2. Visually inspect the Balancer to make sure everything is in place.
3. Make sure the Wheel you want to balance is both clean and free of any weights that may have been put on previously, then mount it.

Refer to [Mounting a Wheel](#) for mounting instructions, if needed.

4. Turn the Balancer Off and then back On, to reset it.

On power up, **USA 512** will appear in the Inner and Outer Windows, followed by default Wheel dimensions.

5. Pull out the Inner Arm and place it against the Inner Edge of the Wheel (where the inner weight will be installed) and hold it there; read the distance off the arm and enter this data into the Balancer using the **Distance +/- key. -A-** will appear in the Inner Display Window and the distance value will appear in the Outer Display Window.
6. Measure the width of the Wheel using the Wheel caliper. Enter this width into the Balancer using the **Width +/- keys. -L-** will appear in the Inner Display Window and the value will appear in the Outer Display Window.
7. Enter the Wheel diameter by reading the size off the Tire sidewall and enter this into the Balancer using the **Diameter +/- keys. -D-** will appear in the Inner Display Window and the diameter value will appear in the Outer Display Window.
8. While facing the Wheel, start spinning the Wheel in a clockwise **U** direction. Begin by pushing the Tire with your hand, then remove your hand from the Tire and turn the Quick Nut black handles to increase the speed of rotation until the Outer Display Window reads **run.**

**⚠ WARNING** Do **not** attempt to stop a rotating Wheel with your hands. Always use the brake. Even though there is no motor driving the Wheel it can severely injure you if it is in motion.

9. Release the handle and wait. The display will go blank then the imbalance values will appear in the Inner and Outer display windows.

- Once the values appear in the display windows, pull the brake against the Tire to stop the rotation.
- When the Wheel stops, look at the values that appear in the Inner and Outer Windows on the Display Panel; this is the unbalanced correction weight required for each plane measured in grams.  
The value that appears in the Inner Window needs to be clipped to the Inner Edge of the Wheel.  
The value that appears in the Outer Window needs to be clipped to the Outer Edge of the Wheel.

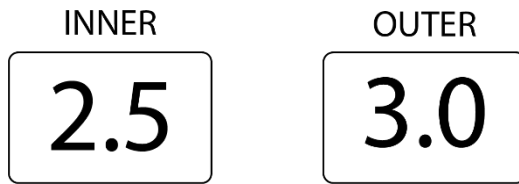

- Turn the Wheel slowly to find the best location to put the weight on the **Inner Edge**. The Inner Edge/Plane placement indicators located under the Inner Display Window light up or go out as you move the Wheel to find the best location to put the weight. When all the indicators on the Inner plane are lit, engage the brake to hold the Wheel and clamp the correct value weight to the inner edge of the Wheel at the 12 o'clock position. (If the Inner Display Window shows **00**, do not add any weight to the Inner Edge).
- Turn the Wheel slowly again to find the best location for the weight on the **Outer Edge**. The Outer Edge/Plane placement indicators located under the Outer Display Window light up or go out as you move the Wheel to find the best location to put the weight. When all the indicators on the Outer Edge/Plane are lit, engage the brake to hold the Wheel and clamp the correct value weight to the outer edge of the Wheel at the 12 o'clock position. (If the Outer Display Window shows **00**, do not add any weight to the Inner Edge).
- Press **S + R** to reset the Balancer and test again using the same Wheel values and balance mode.
- Repeat the process, spin the Wheel again. The Wheel is balanced when both the Inner and Outer Windows show **00**. It may take several attempts to get the imbalance to 0.

## Static Balancing

Static Balancing is for older Wheels under 4 inches wide and motorcycle Wheels.

If the Wheel is out of balance, weight goes on the Center Plane when using Static Mode.

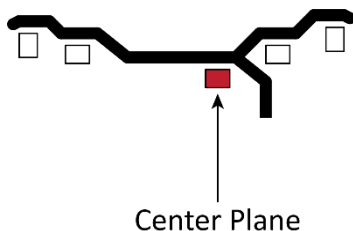

### To Balance a Wheel using Static Mode:

- Make sure you are wearing ANSI-approved eye protection: safety glasses, face shield, or goggles.
- Visually inspect the Balancer to make sure everything is in place.
- Mount the Wheel you want to balance. Verify the Wheel is clean and remove any weights from previous balancing.

Refer to [Mounting a Wheel](#) for mounting instructions, if required.

- 
- Turn the Balancer Off and then back On, to reset it.

On power up, **USA 512** will appear in the Inner and Outer Windows, followed by default Wheel dimensions.

Pull out the Inner Arm and place it against the Inner Edge of the Wheel (where the weight will be installed) and hold it there; read the distance off the arm and enter this data into the Balancer using the **Distance +/- key: -A-** will appear in the Inner Display Window and the distance value will appear in the Outer Display Window. The Outer Window shows distances in millimeters (mm).

- Measure the width of the Wheel using the Wheel caliper. Enter this width into the Balancer using the **Width +/- keys: -L-** will appear in the Inner Display Window and the value will appear in the Outer Display Window.
- Enter the Wheel diameter by reading the size off the Tire sidewall and enter this into the Balancer using the **Diameter +/- keys: -D-** will appear in the Inner Display Window and the diameter value will appear in the Outer Display Window.
- While facing the Wheel, start spinning the Wheel in a clockwise **U** direction. Begin by pushing with your hand against the Tire, then turn the Quick Nut black handles to increase the speed of rotation until the Outer Display Window reads **run.**
- Release the handles and wait. The display will go blank then the imbalance value will appear in the Inner and Outer display windows.
- When the Wheel stops, look at the value that appears in the Inner Window on the Display Panel; this is the unbalanced correction weight required for the center plane measured in oz.

The value that appears in the Inner Window needs to be added to the Center Plane of the Wheel.

INNER

2.5

OUTER

St.

- Turn the Wheel slowly to find the best location to place the weight on the **Center Plane**. The Inner Edge/Plane placement indicators located under the Inner Display Window light up or go out as you move the Wheel to find the best location to put the weight.
- When all the indicators on the Inner plane are lit engage the brake to hold the Wheel and apply the correct value weight to the center edge of the Wheel at the 12 o'clock position. (If the Inner Display Window shows **00**, do not add any weight to the center plane).
- Press **S + R** to reset the Balancer and test again using the same Wheel values and balance mode.
- Spin the Wheel to test the balance again. The Wheel is balanced when both the Inner and Outer Windows show **00**. It may take several attempts to get the imbalance to 0.

---

## Aluminum Alloy Balancing

The following procedure describes the three Aluminum Alloy (ALU) Modes.

**Important:** ALU Modes are for balancing Wheels made of aluminum alloy. The weights can be placed in various locations on these Wheels. *Select the appropriate ALU Mode based on where the weights will be placed.* Adhesive Weights are generally used when you are using ALU Modes (there is one exception), as they are less visible than Clip-On Weights.

### To balance a Wheel using an ALU Mode:

1. Make sure you are wearing ANSI-approved eye protection: safety glasses, face shield, or goggles.
2. Visually inspect the Balancer to make sure everything is in place.
3. Mount the Wheel you want to balance.

Refer to **Mounting a Wheel** for mounting instructions, if needed.

4. Turn the Balancer Off and then back On, to reset it.
5. The instructions for the three ALU Modes are different:

### ALU1

ALU1 Mode is used on Aluminum Alloy Wheels when the weights are to be installed on the Inner and Outer Plane.

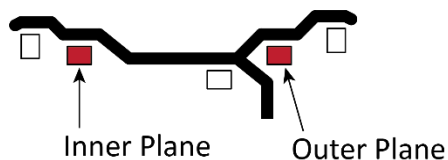

1. Select the ALU 1 Mode by pressing the **F** key until the indicator next to the ALU 1 is lit.
2. Pull out the Inner Arm and place it on the Wheel Inner Edge and hold it there. Read the distance off the arm and enter this data into the Balancer using the **Distance +/- key**. **-A-** will appear in the Inner Display Window and the distance value will appear in the Outer Display Window. Return the inner distance arm to its normal location.
3. Measure the width of the Wheel using the Wheel caliper. Enter this width into the Balancer using the **Width +/- keys**. **-L-** will appear in the Inner Display Window and the value will appear in the Outer Display Window.
4. Enter the Wheel diameter by reading the size off the Tire sidewall and enter this into the Balancer using the **Diameter +/- keys**. **-D-** will appear in the Inner Display Window and the diameter value will appear in the Outer Display Window.
5. While facing the Wheel, start spinning the Wheel in a clockwise **U** direction. Begin by pushing with your hand against the Tire, then turn the Quick Nut black handles to increase the speed of rotation until the Outer Display Window reads **run**.
6. Release the handles and wait. The display will go blank then the imbalance value will appear in the Inner and Outer display windows.
7. Pull the brake to stop the Tire rotation.

---

**⚠ WARNING** Do **not** attempt to stop a rotating Wheel with your hands. Always use the brake. Even though there is no motor driving the Wheel it can severely injure you if it is in motion.

8. When the Wheel stops, look at the values that appear in the Inner and Outer Windows on the Display Panel; this is the unbalanced correction weight required for each plane measured in ounces.

The value that appears in the Inner Window needs to be added to the **Inner Plane** of the Wheel. The value that appears in the Outer Window needs to be added to the **Outer Plane** of the Wheel.

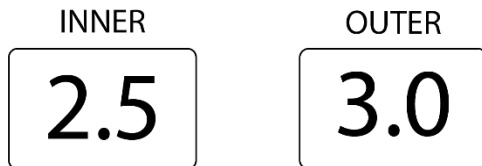

9. Turn the Wheel slowly to find the best location to put the weight on the **Inner Plane**. The Inner Edge/Plane placement indicators located under the Inner Display Window light up or go out as you move the Wheel to find the best location to put the weight.
10. When all the indicators on the Inner plane are lit, engage the brake to hold the Wheel and apply the correct value weight to the inner plane of the Wheel at the 12 o'clock position. (If the Inner Display Window shows **00**, do not add any weight to the Inner Edge).
11. Turn the Wheel slowly again to find the best location for the weight on the Outer Plane. The Outer Edge/Plane placement indicators located under the Outer Display Window light up or go out as you move the Wheel to find the best location to place the weight. When all the indicators on the Outer Edge/Plane are lit, engage the brake to hold the Wheel and clamp the correct value weight to the **Outer Plane** of the Wheel at the 12 o'clock position. (If the Outer Display Window shows **00**, do not add any weight to the Outer Plane).
12. Press **S + R** to reset the Balancer and test again using the same Wheel values and balance mode.
13. Spin the Wheel to test the balance again. The Wheel is balanced when both the Inner and Outer Windows show **00**. It may take several attempts to get the imbalance to **0**.

## ALU2

ALU2 Mode is used on Aluminum Alloy Wheels when the weights are to be applied to the Inner Plane and the Center Plane.

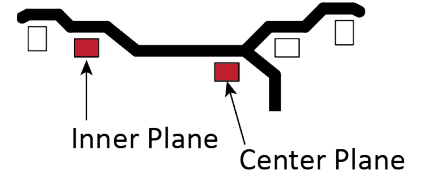

1. Select the ALU 2 Mode by pressing the **F** key until the indicator next to the ALU 2 is lit.
2. Pull out the Inner Arm and place it on the *Inner Edge* and hold it there. Read the distance off the arm and enter this data into the Balancer using the **Distance +/- key**. **-A-** will appear in the Inner Display Window and the distance value will appear in the Outer Display Window.
3. Measure the width of the Wheel using the Wheel caliper. Enter this width into the Balancer using the **Width +/- keys**. **-L-** will appear in the Inner Display Window and the value will appear in the Outer Display Window.
4. Enter the Wheel diameter by reading the size off the Tire sidewall and enter this into the Balancer using the **Diameter +/- keys**. **-D-** will appear in the Inner Display Window and the diameter value will appear in the Outer Display Window.
5. While facing the Wheel, start spinning the Wheel in a clockwise **U** direction. Begin by pushing with your hand against the Tire, then turn the Quick Nut black handles to increase the speed of rotation until the Outer Display Window reads **run**.
6. Release the handles and wait. The display will go blank then the imbalance value will appear in the Inner and Outer display windows.
7. Pull the brake against the Tire to stop the Tire rotation.

**⚠ WARNING** Do **not** attempt to stop a rotating Wheel with your hands. Always use the brake. Even though there is no motor driving the Wheel it can severely injure you if it is in motion.

8. When the Wheel stops, look at the values that appear in the Inner and Outer Windows on the Display Panel; this is the unbalanced correction weight required for each plane measured in grams.

The value that appears in the Inner Window should be added to the **Inner Plane** of the Wheel. The value that appears in the Outer Window should be added to the **Center Plane** of the Wheel.

INNER	OUTER
2.5	3.0

9. Turn the Wheel slowly to find the best location to put the weight on the **Inner Plane**. The Inner Edge/Plane placement indicators located under the Inner Display Window light up or go out as you move the Wheel to find the best location to put the weight. When all the indicators on the Inner plane are lit engage the brake to hold the Wheel and apply the correct value weight to the inner plane of the Wheel at the 12 o'clock position. (If the Inner Display Window shows **00**, do not add any weight to the Inner Plane).
10. Turn the Wheel slowly again to find the best location for the weight on the **Center Plane**. The Outer Edge/Plane placement indicators located under the Outer Display Window light up or go out as you move the Wheel to find the best location to put the weight. When all the indicators on the Outer Edge/Plane are lit, engage the brake to hold the Wheel and apply the correct value weight to

---

the center plane of the Wheel at the 12 o'clock position. (If the Outer Display Window shows **00**, do not add any weight to the Center Plane).

11. Press **S + R** to reset the Balancer and test again using the same Wheel values and balance mode.
12. Spin the Wheel to test the balance again. The Wheel is balanced when both the Inner and Outer Windows show **00**. It may take several attempts to get the imbalance to 0.

## ALU3

ALU3 Mode is used on Aluminum Alloy Wheels when you want the weights applied to the Inner Plane and the Outer Edge.

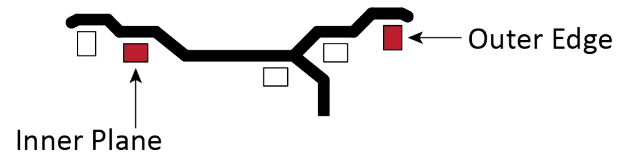

1. Select the ALU 3 Mode by pressing the **F** key until the indicator next to the ALU 3 is lit.
2. Pull out the Inner Arm and place it on the Wheel *Inner Edge* and hold it there. Read the distance off the arm and enter this data into the Balancer using the **Distance +/- key**. An **-A-** will appear in the Inner Display Window and the distance value will appear in the Outer Display Window. Return the Inner Arm to its normal location.
3. Measure the width of the Wheel using the Wheel caliper. Enter this width into the Balancer using the **Width +/-** keys. An **-L-** will appear in the Inner Display Window and the value will appear in the Outer Display Window.
4. Enter the Wheel diameter by reading the size off the Tire sidewall and enter this into the Balancer using the **Diameter +/-** keys. A **-D-** will appear in the Inner Display Window and the diameter value will appear in the Outer Display Window.
5. While facing the Wheel, start spinning the Wheel in a clockwise **U** direction. Begin by pushing with your hand against the Tire, then turn the Quick Nut black handles to increase the speed of rotation until the Outer Display Window reads **run**.
6. Release the handles and wait. The display will go blank then the imbalance value will appear in the Inner and Outer display windows.
7. Pull the brake to stop the Tire rotation.

**⚠ WARNING** Do **not** attempt to stop a rotating Wheel with your hands. Always use the brake. Even though there is no motor driving the Wheel it can severely injure you if it is in motion.

8. When the Wheel stops, look at the values that appear in the Inner and Outer Windows on the Display Panel; this is the unbalanced correction weight required for each plane measured in grams.

The value that appears in the Inner Window should be added to the **Inner Plane** of the Wheel. The value that appears in the Outer Window should be added to the **Outer Edge** of the Wheel.

INNER	OUTER
2.5	3.0

9. Turn the Wheel slowly to find the best location to put the weight on the Inner Plane. The Inner Edge/Plane placement indicators located under the Inner Display Window light up or go out as you move the Wheel to find the best location to place the weight. When all the indicators on the Inner plane are lit engage the brake to hold the Wheel and apply the correct value weight to the **Inner Plane** of the Wheel at the 12 o'clock position. (If the Inner Display Window shows **00**, do not add any weight to the Inner Plane).
10. Turn the Wheel slowly again to find the best location for the weight on the Outer Plane. The Outer Edge/Plane placement indicators located under the Outer Display Window light up or go out as you move the Wheel to find the best location to put the weight.

- 
11. When all the indicators on the Outer Edge/Plane are lit, engage the brake to hold the Wheel and apply the correct value weight to the Outer Edge of the Wheel at the 12 o'clock position. (If the Outer Display Window shows **00**, do not add any weight to the Inner Edge).
  12. Press **S + R** to reset the Balancer and test again using the same Wheel values and balance mode.
  13. Spin the Wheel to test the balance again. The Wheel is balanced when both the Inner and Outer Windows show **00**. It may take several attempts to get the imbalance to **0**.

---

## Calibration

Calibrate the Balancer on a regular basis using the 100 g weights included with the AB24M.

**IMPORTANT** When placing the calibration weights on Wheels, apply weights exactly perpendicular to the shaft at the 12 o'clock position. Incorrect placement will result in additional weight call outs and/or an improperly calibrated machine.

### To Calibrate the Balancer:

1. Install a known good Wheel on the Balancer.
2. Enter the Wheel Inside Distance, Width and Diameter.
3. Press and hold the **R** and **F** keys at the same time. Both Inner and Outer Display windows should display **CAL** and the Wheel position indicators should be flashing. Hold the keys down until the Wheel position indicators stop flashing (about 5 seconds) then release.
4. While facing the Wheel, start spinning the Wheel in a clockwise  direction. Begin by pushing with your hand against the Tire, then turn the Quick Nut black handles to increase the speed of rotation until the Outer Display Window reads **run**.
5. Release the Quick Nut handles and wait. After a few seconds, the inner and outer display should read:



6. Pull the brake handle against the Tire to stop the rotation.
7. Slowly turn the Wheel until all the inner weight position indicators are lit. Use the brake to hold the Wheel in place.
8. Clamp a 100 g calibration weight to the top dead center position on the inner edge of the Tire.
9. While facing the Wheel, start spinning the Wheel in a clockwise direction. Begin by pushing with your hand against the Tire, then turn the Quick Nut black handles to increase the speed of rotation until the Outer Display Window reads **run**.
10. Release the Quick Nut handles. After a few seconds, the inner and outer display should read:



11. Pull the brake against the Tire to stop the rotation.
12. Slowly turn the Wheel until all the outer weight position indicators are lit. Use the brake to hold the Wheel in place.
13. Remove the 100 g calibration weight from the inside edge and move it to the top dead center position on the Outer Edge of the Tire.

- 
14. Rotate the Wheel in a clockwise direction again by hand, then increase the speed of rotation using the Quick Nut handles. When the Wheel gets up to speed, the display should say **run**. After a few seconds, the Inner and Outer display should read **END CAL**.
  15. Pull the brake handle against the Tire to stop the rotation.
  16. While facing the Wheel, start spinning the Wheel in a clockwise direction. Begin by pushing with your hand against the Tire, then turn the Quick Nut black handles to increase the speed of rotation until the Outer Display Window reads **run**.
  17. After a few seconds, the inner and outer display should show weight data for 8 seconds.
  18. Calibration is successful if:
    - a. The Balancer weight shows 100 g  $\pm$ 4 grams.
    - b. When turning the Wheel slowly to light all the outside Wheel weight indicators the outside edge 100 gram weight is at the 6 o'clock low position  $\pm$ 4° with all the weight position indicators lit.

# Maintenance

Make sure your Wheel Balancer is maintained on a regular basis.

## Regular Maintenance

**⚠ DANGER** Disconnect the Power Cord from power **before performing any maintenance** and take whatever steps are necessary to make sure the unit cannot be re-energized until Maintenance is completed. Because the unit uses electricity, you could be electrocuted or even killed if the unit is powered back on during Maintenance.

### To maintain your Wheel Balancer:

- **Daily:** Make sure the unit is clean and dry before using it.
- **Weekly:** Make sure the alignment mark on the Shaft Assembly is correctly aligned with the Shaft Housing and is securely tightened.

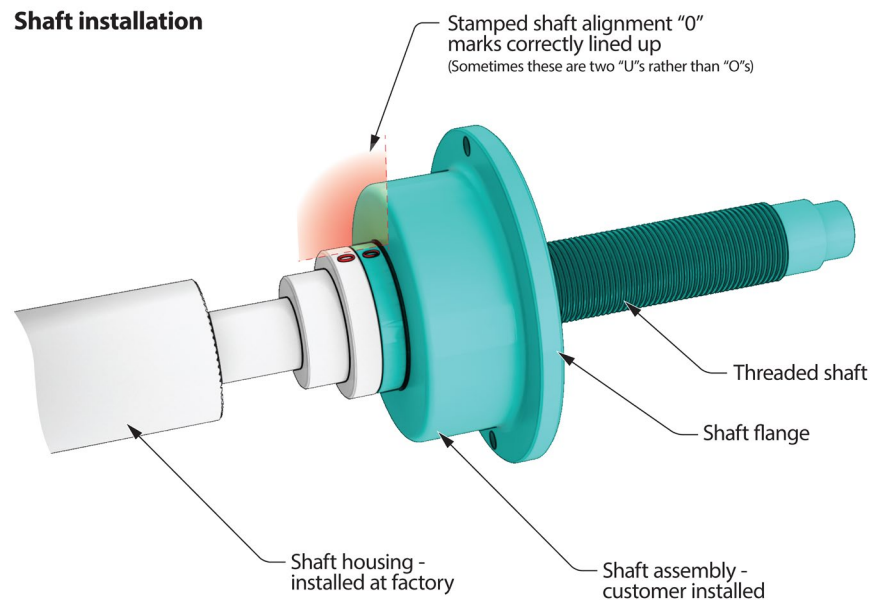

- **Weekly:** Unplug the Balancer to remove power. Clean the display with a rag. Do NOT soak the unit with water.
- **Monthly:** Make sure all Anchor Bolts are tightened and secure.
- **Monthly:** Check all components to make sure they are in good operating condition. If you find a component that is **not** working correctly, take the unit out of service and refer to **Troubleshooting** for more information.
- **Every three months:** Check the Bolts on the components attached to the unit to make sure they are tight and secure.
- **Yearly:** Have an Electrician come out and check the electronic components.
- **Yearly:** Take the unit out of service, disconnect the Power Cord from the power source, and then thoroughly check and clean all components.

**⚠ WARNING** Do not operate your Wheel Balancer if you find issues; instead, take the unit out of service, then contact your dealer, visit [BendPak.com/support](https://www.bendpak.com/support) or call **(877) 432-6627**.

---

# Troubleshooting

Perform the following checks if you are experiencing balancing problems:

- Confirm the location and alignment of the marks on the Shaft Assembly and Shaft Housing (see **Installing the Shaft** for more information).
- Make sure the Balancer is anchored in place (see **Anchoring the Balancer** for more information).
- Perform a Calibration (see **Calibration** for more information).

Perform the calibration with a steel Wheel of the most commonly used size.

**Note:** It is a good practice to keep a known good Wheel of the most commonly used size to use as a calibration / reference Tire to assist in troubleshooting.

Make sure the calibration weight used is a 100 gram or 3.5 ounce weight and that is mounted correctly during the calibration procedure.

**⚠ WARNING** **For Generator users and or areas with frequent brown-out conditions.** Premature component failure due to excessive high or low voltage is **not** covered under warranty. Verify that the power supply can provide the required current and voltage. While voltage variations are common ( $\pm 5\%$ ) both high and low voltage episodes in excess of 15% to 20% can cause premature electrical and electronic component failure.

## Issues

Issue/Error Code	Action
Nothing on the Display Panel.	<ol style="list-style-type: none"><li>1. Make sure the Balancer's rocker switch is in the on position and power is being supplied to the Balancer.</li><li>2. Verify rocker switch is undamaged and functioning.</li></ol>
The Balancer is not producing good balances on a consistent basis.	Perform the 100 g calibration.
Weight correction varies by over 5g on every rotation.	<ol style="list-style-type: none"><li>1. Clean Tires of foreign matter.</li><li>2. The Wheel center may be damaged or deformed.</li><li>3. External voltage supply is low.</li><li>4. Tire pressure may be low, inflate to the correct pressure.</li><li>5. Pressure sensor may be wet. Dry the sensor and readjust.</li><li>6. Quick Nut may not be fully clamped, tighten.</li></ol>
Weight correction varies by dozens or more grams for every rotation.	<ol style="list-style-type: none"><li>1. Clean Tires of foreign matter.</li><li>2. The sensor may be damaged, replace it.</li><li>3. The external power supply voltage is low. Verify input voltage.</li></ol>
Correction weight error is too large.	<ol style="list-style-type: none"><li>1. Clean foreign matter from the Tire.</li><li>2. The Tire may not be mounted properly on rim.</li><li>3. Perform calibration with a known good Wheel and Tire.</li></ol>

<b>Issue/Error Code</b>	<b>Action</b>
The Wheel will not stop.	Verify that the brake handle is connected. Replace any damaged or worn parts.
The imbalance exceeds 10g after first weight correct.	<ol style="list-style-type: none"> <li>The Wheel's inner plane may be irregular.</li> <li>The Wheel's center may be deformed.</li> <li>The Balancer shaft matcher is not mounted properly. Check installation surfaces and re-install.</li> </ol>
The imbalance weight exceeds a few hundred grams.	<ol style="list-style-type: none"> <li>Tire parameter(s) are incorrect, re-enter them. <ol style="list-style-type: none"> <li>Inside distance measurement.</li> <li>Wheel Width.</li> <li>Wheel Diameter.</li> </ol> </li> <li>The Tire error is too large, replace the Tire.</li> </ol>
00	<ol style="list-style-type: none"> <li>The sensor is wet or damaged, re-adjust the sensor, conduct the 100 g calibration after drying or replace the sensor.</li> <li>The processor program is corrupted. Replace circuit board.</li> </ol>
00-00	<ol style="list-style-type: none"> <li>Sensor leads are broken or disconnected. Repair or reconnect.</li> <li>Memory values lost, perform the 100 g calibration.</li> </ol>
Err1	<ol style="list-style-type: none"> <li>Check photoelectric circuit board.</li> <li>Check the Computer Board</li> </ol>
Err2	<ol style="list-style-type: none"> <li>Insufficient speed of rotation. Speed up the rotation.</li> <li>Replace the Photoelectric Board.</li> <li>Replace the Computer Board.</li> </ol>
Err3	<ol style="list-style-type: none"> <li>The unbalanced amount is too large.</li> <li>Replace with a new Wheel.</li> <li>Conduct the 100 g calibration.</li> </ol>
Err4	Photoelectric sensor problem. Readjust the sensor position or replace.
ErrH	Wheel speed is too fast. Slow down the rotation.
Err8	<ol style="list-style-type: none"> <li>100 g weight was not correctly applied.</li> <li>Check internal wiring harness for disconnected or broken wires.</li> <li>Check power supply for broken wires.</li> <li>Computer Board fault, remove and replace.</li> </ol>

If you continue to have problems with your Wheel Balancer, visit [APEX.com/support](https://www.apex.com/support) or call APEX at **(877) 432-6627**.

## Pressure Sensor Adjustment

This adjustment is to be performed if the sensors are damaged or if Error Code 00 appears on the display. Refer to **Figure H** below.

### To Adjust the Pressure Sensors:

1. Open the cover under the main shaft.
2. Loosen Nuts (2) (3) (4) and (5).
3. Loosen Nut (1).
4. Remove vertical and horizontal rods.
5. Dry the sensor elements (6) and (7).
6. Replace the vertical and horizontal rods.
7. Tighten Nut (4) finger tight.
8. Tighten Nut (5).
9. Tighten Nut (2) finger tight.
10. Tighten Nut (3).

**Figure H**

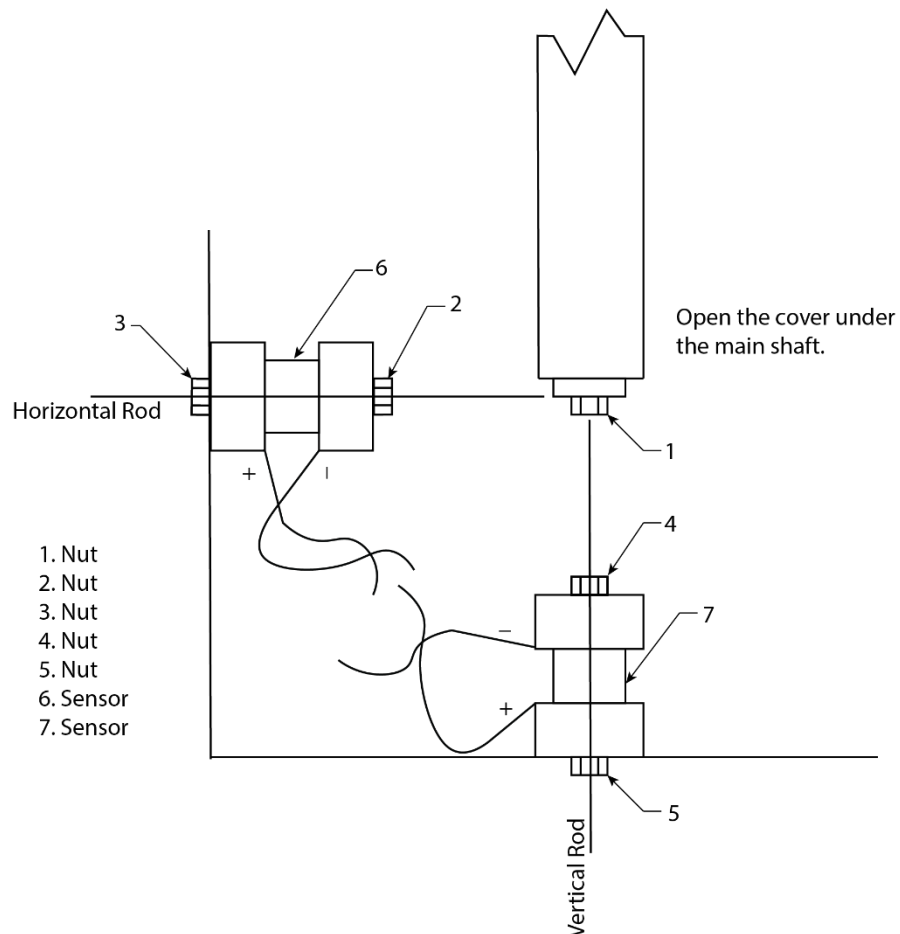

# Wiring Diagram

230 V Power Board

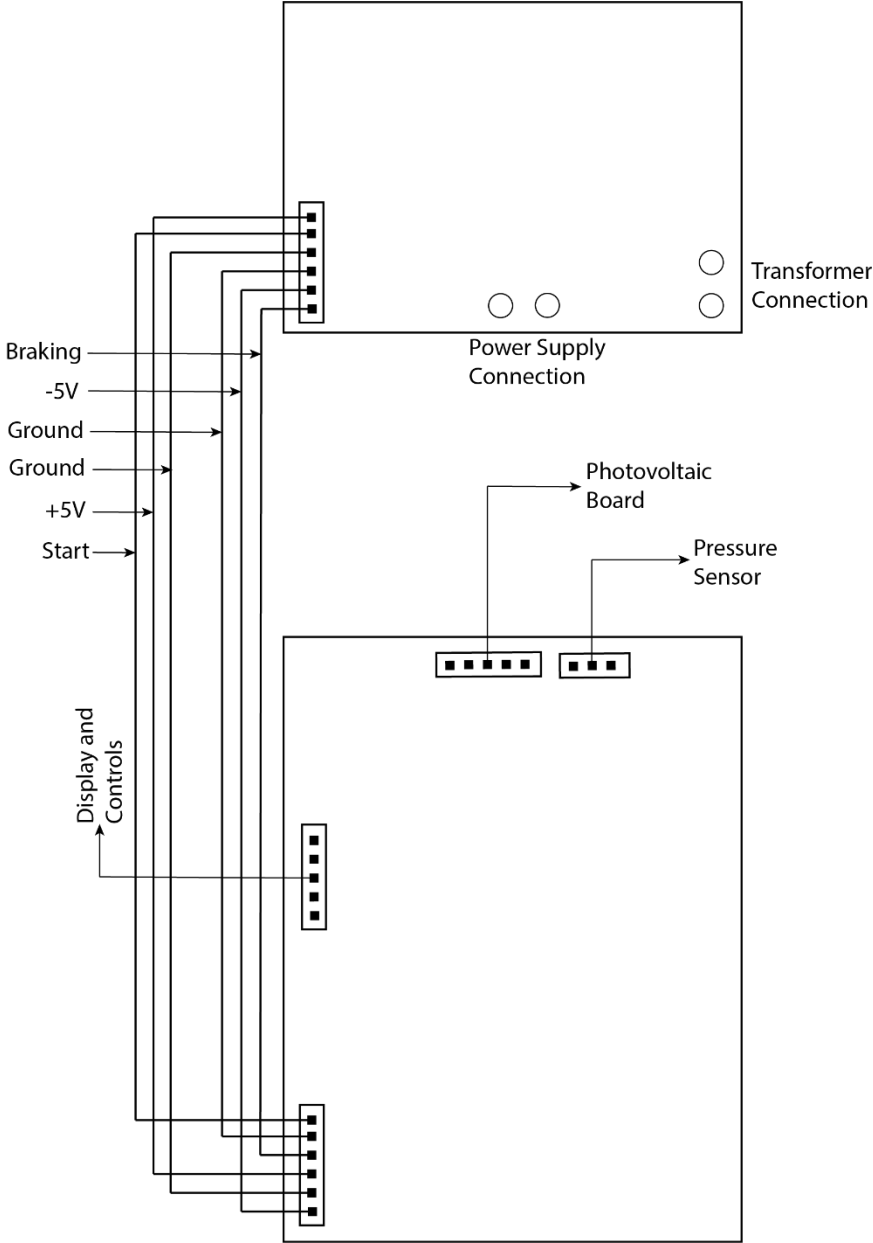

# Labels

**A**

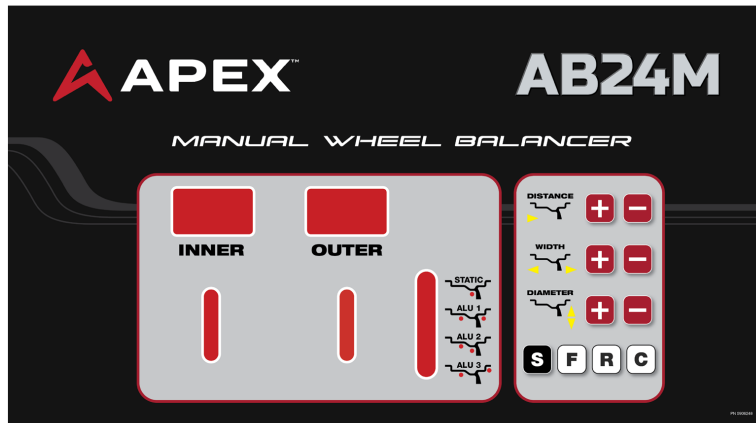

PN 5906248

**APEX AB24M Display Panel 5906248**  
Size: 15.75 in. (W) x 8.75 in. (H)

**B**

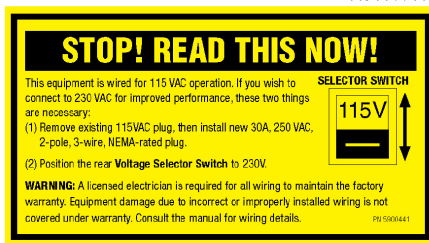

PN 5900441

**RNGR Volt\_Caution\_Decal\_115V\_5900441**  
Size: 4.5 in. W x 2.5 in. H

**C**

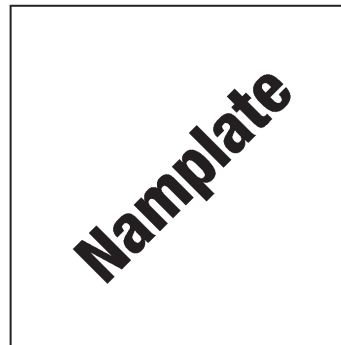

PN 5906152

**Ranger-CoolBoss 3x3-Namplate\_Label\_B\_5906152**  
Size: 3 in. W x 3 in. H

**D**

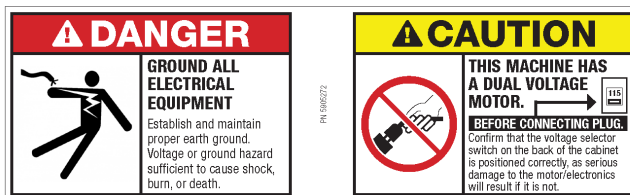

PN 5905272

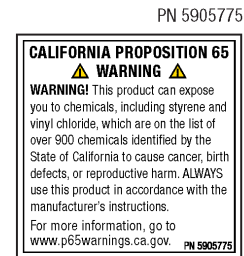

**Voltage\_Plug\_Danger\_Label\_5905272-REV-B**  
Size: 6.5 in. W x 2 in. H

**E**



PN 5905775

**Prop\_65\_Label-5905775\_Rev\_01**  
Size: 1.5 in. W x 1.5 in. H

MACHINE PAINT COLORS					
	RAL 9017 (20% Gloss)		RAL 3003 (20% Gloss)		RAL 1018 (20% Gloss)

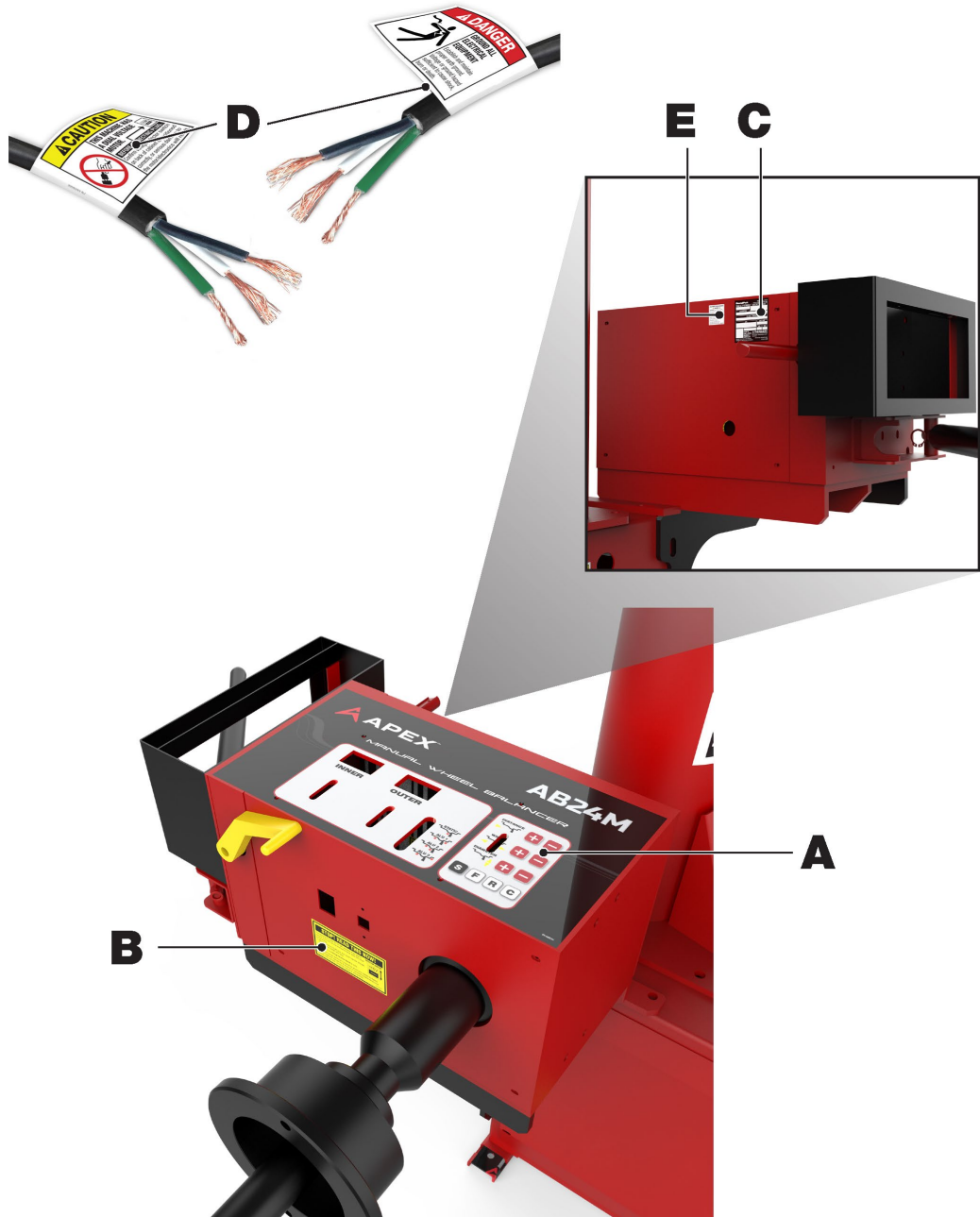

# Parts

## Cabinet Assy.

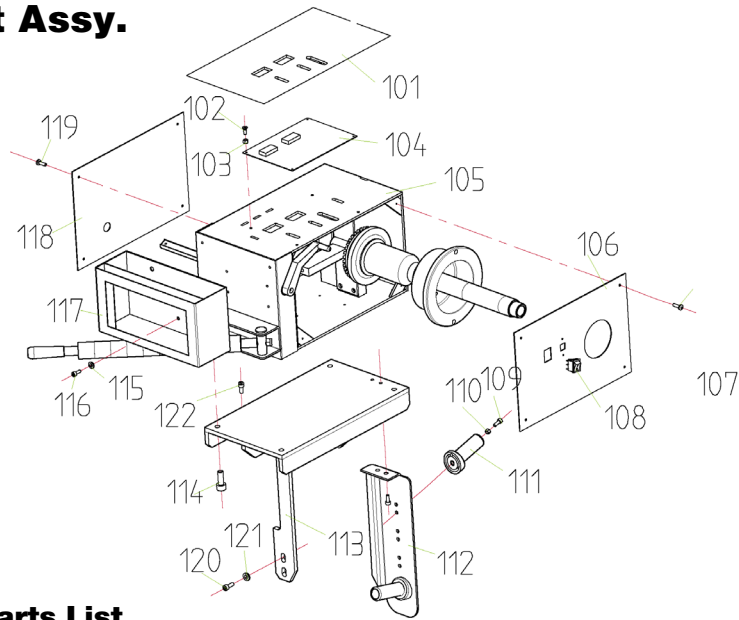

### Cabinet Parts List

#	Part Number	Description
101		Display Membrane
102	5530304	Cross Recessed Countersunk Head Screw M3x30
103		Hexagon Nut M3
104		Computer Board
105		Cabinet
106		Dam-board
107		Cross Recessed Pan Head Screw M4X10
108	5525251	OFF/ON Switch
109		SHCS M6X30
110		Hexagon Nut M6
111		Cone Hanger
112		Tool Holder Mounting Plate
113	5327132	Weldment, Base Assembly (Welded Piece)
114		SHCS M10X20
115		Washer $\phi 6$
116		SHCS M6X16
117		Side Storage Rack
118		Dam-board
119		Cross Recessed Pan Head Screw M4X10
120		SHCS M10X25
121		Washer $\phi 10$
122		SHCS M10X50

## Main Shaft Assy.

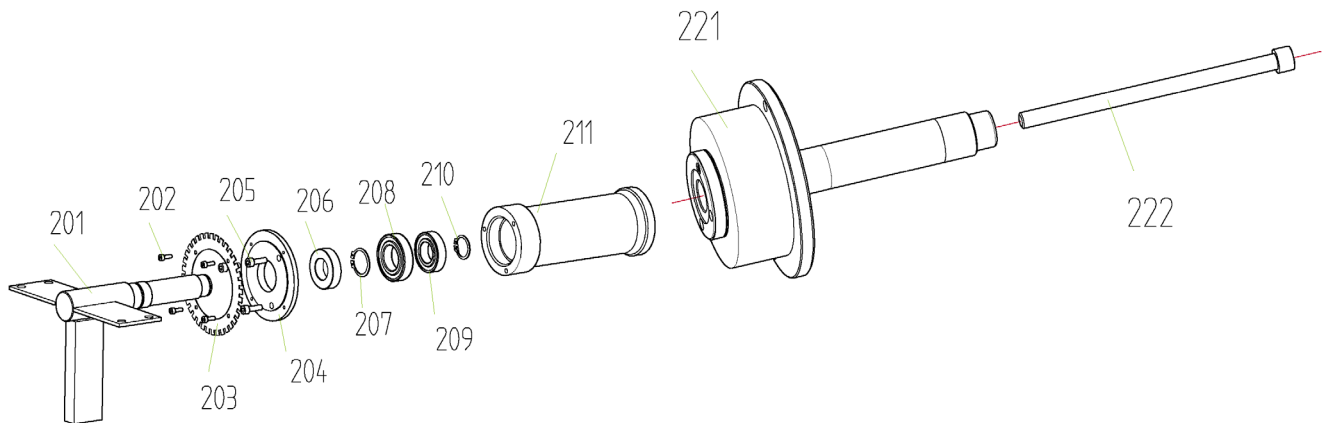

### Main Shaft Parts List

#	Part Number	Description
201		Deformation Of Beams
202		SHCS M4X12
203		Tooth 32T
204		Bearing Cover
205		SHCS M6X20
206		Nut M30x1.5
207		Snap ring; 30
208		Bearing; 6006
209		Bearing; 6005
210		Seeger Ring; 25
211	5327179	Spindle Bushing Weldment
221		Thread Shaft/Spindle
222	5327330	SHCS M14X240mm

## Pressure Sensor Assy.

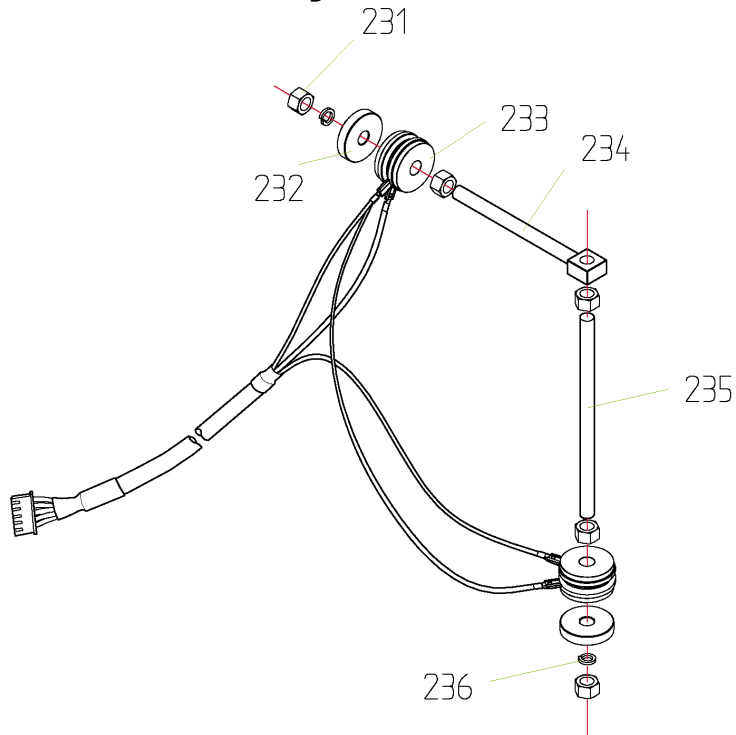

### Pressure Sensor Assy. Parts List

#	Part Number	Description
231		Hexagon Nut M10
232		Piezo Pad
233		Sensor
234	5327140	Piezo Horizontal Shaft
235	5327139	Piezo Vertical Shaft
236		Spring Washer, M10

## Encoder Board (Encored)

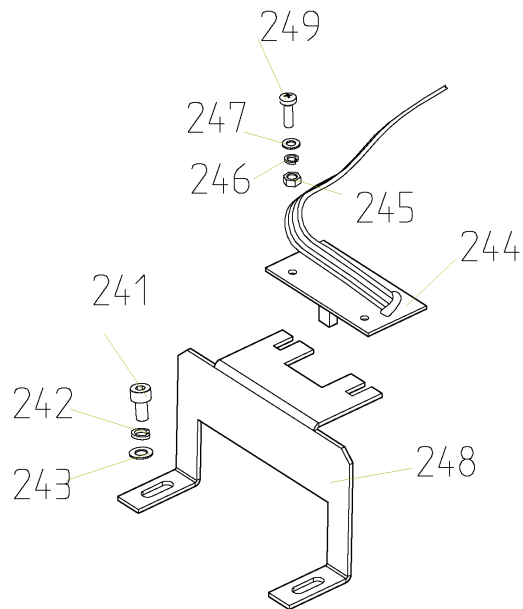

### Encoder Board\* Assy. Parts List

#	Part Number	Description
241	5327870	SHCS M4X8
242		Spring pad M4
243		Washer M4
244	5327090	Photovoltaic Panels;
245		Hexagon Nut M3
246		Spring Pad M3
247		Washer M3
248		Encoder Bracket;
249		Cross Recessed Pan Head Screw M3 x 10

## Inner Distance Arm Assy.

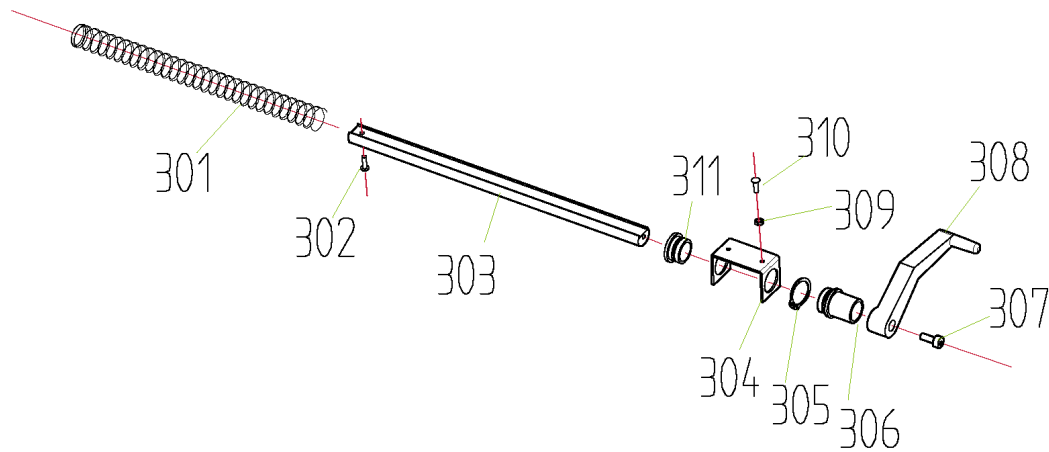

### Inner Distance Arm Parts List

#	Part Number	Description
301		Distance Arm Spring;
302		Spring Column Pin
303		Distance Arm Rod;
304		Pull Ruler Fixing Frame
305		Snap Ring 25
306		Long Pull Rod Set
307		SHCS M6X16
308		Inner Distance Handle
309		Washer $\phi 6$
310		SHCS M6X16
311		Short Pull Rod Set

## Computer Board Assy.

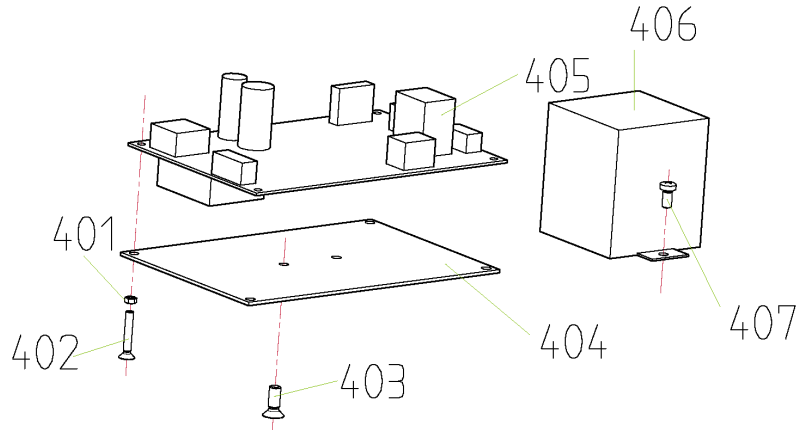

### Computer Board Assy. Parts List

#	Part Number	Description
401		Hexagon Nut M3
402		Cross Recessed Countersunk Head Screw M3x30
403		Cross Recessed Countersunk Head Screw M6x12
404		Power Liner Assembly Welding
405		Power Board
406	5327146	Transformer
407		Cross Recess Pan Head Screw M4x16

## Brake Assy.

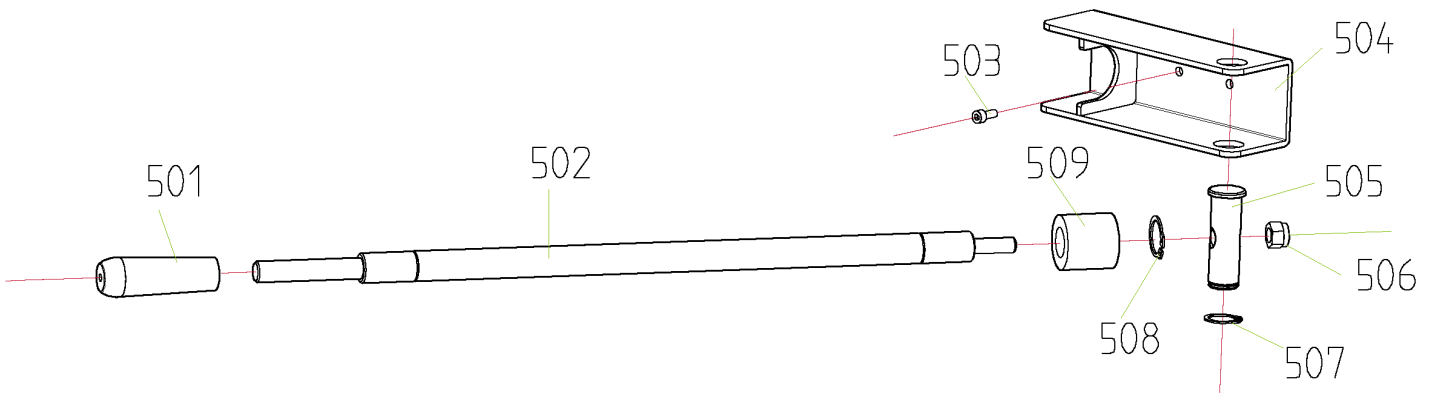

### Brake Assy. Parts List

#	Part Number	Description
501	5327591	Handle
502	5328023	Brake Shaft (Crowbar Shaft)
503		SHCS M6x16
504		Coaming Assembly Welding Piece
505		Pin Roll
506	5328022	Lock Nut M10
507		Snap Ring; 20
508		Snap Ring; 20
509		Rubber Ring

## Accessories

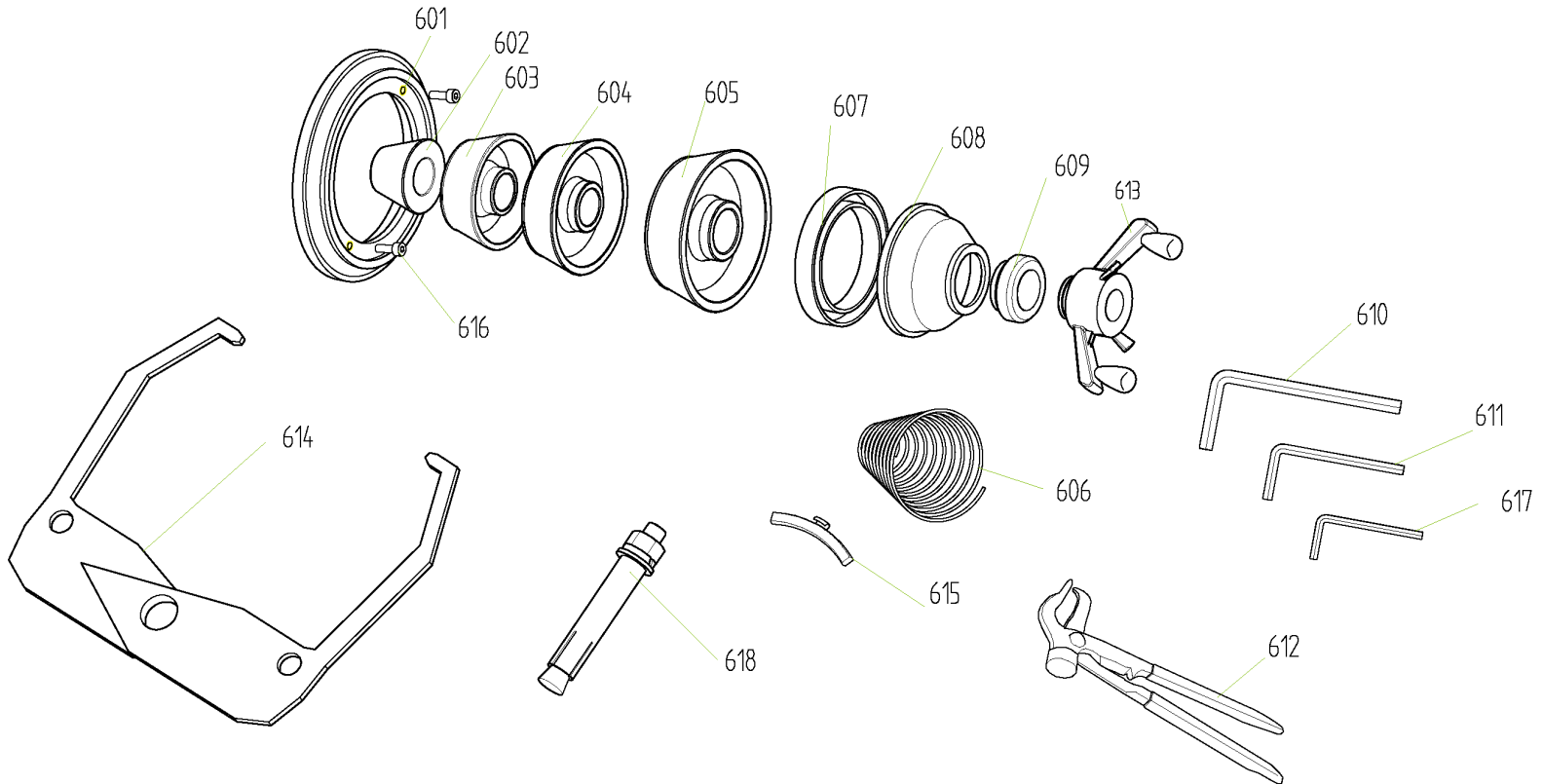

### Accessory Parts List

#	Part Number	Description
601	5327063	Spacer Ring
602	5327069	CONE 1
603	5327071	CONE 2
604	5327067	CONE 3
605	5327065	CONE 4
606		Mounting Spring; 36mm
607	5327074	Quick Nut Cup
608	5327061	Quick Nut Cup Cover
609	5327172	Quick Nut Cover
610	5327720	Allen Wrench; 12mm
611	5328055	Allen Wrench; 6mm
612	5346425	Weight Hammer Pliers
613		Quick Nut; 36mm
614	5402187	Wheel Width Caliper
615	5346879	Calibration Weight
616	5530304	SHCS M8x20
617		Allen Wrench; 8mm;
618		Anchor Bolt; M10X100





30440 Agoura Road  
Agoura Hills, CA 91301 USA  
[bendpak.com/apex](https://bendpak.com/apex)