

HD-7500 SERIES

BendPak®

HD-7500BLX SKU# 5175315

HD-75BXT SKU#5175251

HD-7500PBX SKU#5175320

Four-Post Boat Lifts

7,500-lb. Capacity / Vehicle and Boat Storage Lift

THE PERFECT BOAT STORAGE LIFT

Never trust your precious boat to the unpredictability of the water, nor should you pay for dry docks and/or yard storage. Salt water corrosion, barnacles, rust damage, rub marks, coating blemishes, rot and cold weather can do irreversible harm caused to your boat's engine and interior. The longer you go without a boat storage lift, the more you leave yourself open to catastrophe.

BendPak has the perfect solution: Keep your boat up in the air and out of the water. Because it features adjustable runways that accommodate cars and trucks, the HD-7500 Series pulls double-duty as a professional-grade car lift for vehicles.

NO MORE DOCKING FEES

A boat lift is a great way to shield yourself from monthly boata storage fees. The larger the boat, the bigger the bill, so there's no better way to keep your boat safe than to store it in your own garage.

FITS MOST BOAT TRAILERS

Wide and narrow installations help accommodate virtually all boat trailer types.

FEATURES

- 7,500-lb. lifting capacity
- Two different lifting heights to choose from
- Electric / hydraulic power system
- Internal anti-sway slider blocks in each column
- Both models feature heavy-duty 3/8 in. aircraft cable
- Multi-position safety locks in each column
- Ramps feature non-skid surface
- Runways include rail-kit for optional accessories
- Single hydraulic cylinder underneath runway
- Over-sized self-lubricating cable rollers
- Rugged 1-1/4 in. roller axles
- Adjustable lock ladders
- Push-button pneumatic safety release
- Durable powder coat finish

Note: An air supply (minimum 30 psi / 3 CFM) is required for the safety-lock mechanisms to disengage. It is solely the responsibility of the end-user to provide, install and maintain the air supply. Not all BendPak lift models meet the standards as prescribed by ANSI/ALI ALCTV-2017 or ANSI/UL 201. Consult www.autolift.org for a complete list or contact BendPak via contact@bendpak.com

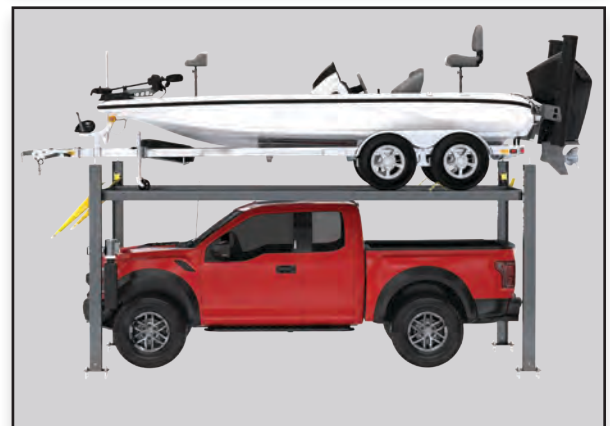

OPTIONAL CROSSBEAM ADAPTER SET

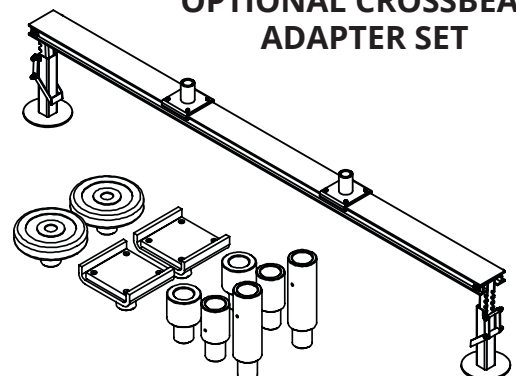

THE PERFECT BOAT STORAGE SOLUTION

FEATURES & SPECS

- No more docking fees
- Heavy-duty aircraft cable
- Electric-hydraulic power system
- Single hydraulic cylinder
- Dual-hub wire rope sheaves
- Multi-level locking positions
- Longer approach ramps

HD-7500PBX

Extended Height Model



SKU#5175320

HD-7500BLX



SKU# 5175315

HD-75BXT

Extended Length Model



SKU#5175251

	HD-7500BLX	HD-75BXT	HD-7500PBX
Lifting Capacity	7,500 lbs / 3,402 kg		
Maximum Capacity Front Axle	3,750 lbs. / 1,701 kg		
Maximum Capacity Rear Axle	3,750 lbs. / 1,701 kg		
Min. Runway Height, Lowered	5 in. / 125 mm		
Maximum Rise	82 in. / 2,058 mm	82 in. / 2,058 mm	144.5 in. / 3681 mm
Maximum Lifting Height	87 in. / 2,208 mm	87 in. / 2,208 mm	132 in. / 3357 mm
Overall Width	132 in. / 3,353 mm (with fasteners 133.75 in. / 3,398 mm)		
Outside Length	198 in. / 5,028 mm	222 in. / 5638 mm	198 in. / 5,028 mm
Overall Length	224.5 in. / 5,704 mm	248.5 in. / 6313 mm	224.5 in. / 5,704 mm
Height Of Post	100 in. / 2,537 mm	100 in. / 2,537 mm	157.5 in. / 4010 mm
Distance Between Posts	122 in. / 3,103 mm		
Drive-Through Clearance	108.5 in. / 2,756 mm		
Runway Width	19 in. / 482 mm		
Runway Length	188.5 in. / 4,788 mm	212.5 in. / 5398 mm	188.5 in. / 4,788 mm
Width Between Runways	49.5 – 69.5 in. / 1,257 mm – 1,765 mm	46.5 – 66.5 in. / 1,181mm –1689 mm	49.5 in. – 69.5 in. / 1,257 mm – 1,765 mm
Outside Edge Of Runways	87.5 in. (narrow) or 107.5 in. (wide) / 2,223 mm or 2,731 mm		
Locking Positions	17 spaced every 4 in. / 102 mm	17 spaced every 4 in. / 102 mm	30 spaced every 4 in. / 102 mm
Motor	208-230 VAC, 60 Hz, 1 Ph		
Air Supply	3 to 25 CFM at 50 to 150 psi		