



PLEASE READ THE ENTIRE CONTENTS OF THIS MANUAL PRIOR TO INSTALLATION AND OPERATION. BY PROCEEDING YOU AGREE THAT YOU FULLY UNDERSTAND AND COMPREHEND THE FULL CONTENTS OF THIS MANUAL. FORWARD THIS MANUAL TO ALL OPERATORS. FAILURE TO OPERATE THIS EQUIPMENT AS DIRECTED MAY CAUSE INJURY OR DEATH.

Manual Revision A1 - May 2020
Manual Part Number 590229

INSTALLATION AND OPERATION MANUAL

BUBBLE BALANCER
MODEL: RWS-1B



Keep this operation manual near the machine at all times. Make sure that ALL USERS read this manual.

SHIPPING DAMAGE CLAIMS

When this equipment is shipped, title passes to the purchaser upon receipt from the carrier. Consequently, claims for the material damaged in shipment must be made by the purchaser against the transportation company at the time shipment is received.

BE SAFE

Your new Bubble Balancer was designed and built with safety in mind. However, your overall safety can be increased by proper training and thoughtful operation on the part of the operator. DO NOT operate or repair this equipment without reading this manual and the important safety instructions shown inside.



1645 Lemonwood Dr.
Santa Paula, CA. 93060, USA
Toll Free 1-800-253-2363
Tel: 1-805-933-9970
Fax: 1-805-933-9160
www.rangerproducts.com

BUBBLE BALANCER

WARRANTY POLICY

Ranger Products™ are backed by over 40 years of manufacturing experience. Every Bubble Balancer bearing the Ranger™ name is sold with the following warranty.

- Each Ranger Product™ is warranted to be free from defects in workmanship and material for a period of one year from the date of shipment provided that a written claim for such defect is made within that time.
- This warranty does not cover damage or defects caused by carelessness of the operator, misuse, abuse or abnormal use which in any way impairs the proper functioning of the equipment or by the use or addition of parts not manufactured by Ranger Products™ or its suppliers.

THIS WARRANTY IS EXPRESSLY MADE IN LIEU OF ANY AND ALL OTHER WARRANTIES EXPRESSED OR IMPLIED INCLUDING THE WARRANTIES OF MERCHANTABILITY AND FITNESS OR A PARTICULAR PURPOSE.

If your Ranger Products™ machine is not functioning properly, call your Ranger Products™ dealer immediately. On some occasions, an independent contractor may be hired to do the repairs. Within the warranty period, a customer should not hire his own contractor unless it is authorized in writing by Ranger Products™.

If it is necessary to return equipment for repairs, your dealer will so advise you. When returning equipment for repairs, see that machines are properly crated and protected, and prepay transportation.

Defective parts replaced at no charge must be returned to your dealer or Ranger Products™ within 60 days of the date that the replacement parts are shipped; otherwise, you must pay for the replacement parts at the current selling price.

OPERATOR PROTECTIVE EQUIPMENT

Personal protective equipment helps keep equipment use safer. However, equipment does not take the place of safe operating practices. Always wear durable work clothing. Shop aprons or shop coats may also be worn, however loose fitting clothing should be avoided. Tight fitting leather gloves are recommended to protect operators. Sturdy leather work shoes with steel toes and oil resistant soles should be used by personnel to help prevent injury in typical shop activities.

Eye protection is essential during installation and operation. Safety glasses with side shields, goggles, or face shields are acceptable. Back belts provide support during lifting activities and are also helpful in providing operator protection. Consideration should also be given to the use of hearing protection if activity is performed in an enclosed area, or if noise levels are high.



OWNER'S RESPONSIBILITY

To maintain machine and user safety, the responsibility of the owner is to read and follow these instructions:

- ◆ Follow all installation instructions.
- ◆ Make sure installation conforms to all applicable Local, State, and Federal Codes, Rules, and Regulations; such as State and Federal OSHA Regulations and Electrical Codes.
- ◆ Carefully check the unit for correct initial function.
- ◆ Read and follow the safety instructions. Keep them readily available for machine operators.
- ◆ Make certain all operators are properly trained, know how to safely and correctly operate the unit, and are properly supervised.
- ◆ Allow unit operation only with all parts in place and operating safely.
- ◆ Carefully inspect the unit on a regular basis and perform all maintenance as required.
- ◆ Service and maintain the unit only with authorized or approved replacement parts.
- ◆ Keep all instructions permanently with the unit and all decal's on the unit clean and visible.

TOOLS REQUIRED

Adjustable Wrench or Metric open end/combination wrenches, phillips head screwdriver.

ASSEMBLY INSTRUCTIONS

1. Assemble the Bubble Balancer as shown using the Parts Breakdown on Page 5 as a guide.

CALIBRATING THE BALANCER

1. With the Balancer located on a firm stable surface or floor. Use the three Level Bubble Mounting screws (3) to center the Level Bubble in the black circle. Tightening a screw will move the bubble away from that screw. Make sure the Air Bubble is centered inside of the Black Circle inside in the Bubble Assembly.

BALANCING A TIRE / WHEEL ASSEMBLY

1. Remove the tire and wheel from the vehicle. Remove any old weights and clean off any debris from the inside and underside of the rim. Check and clean the hole of the rim to insure uniform seating on the Balancer Cone Assembly.

2. Place the tire/wheel assembly on the Balancer. Check for uniform seating when the tire/wheel rim engages the cone. Let the tire/wheel settle to a stop.

3. Check the Bubble Level for an out of balance condition. The Bubble will move outside of the black circle in the opposite direction from the heavy side. (See Fig. 1)

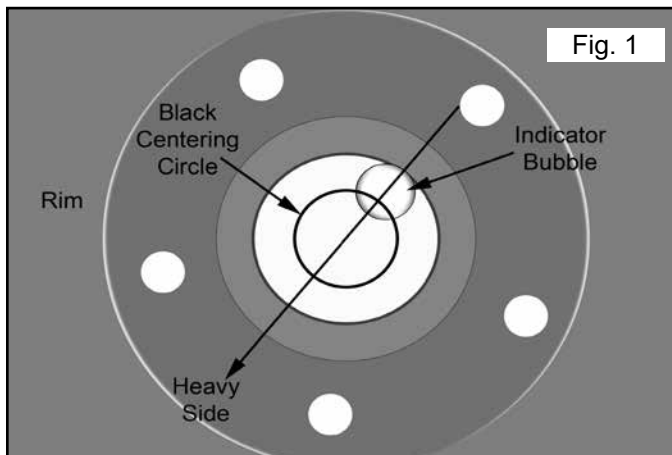

4. Place a weight on the light side of the rim closest to the bubble. If the first weight does not bring the Bubble back to the middle of the black circle, place a large (heavier) weight or smaller (lighter) weight on the rim until the Indicator Bubble settles in the center of the Black Circle.

5. Remove the tire/wheel assembly from the Balancer and place the proper amount of weight needed on both sides of the rim. For example, if the required weight is 3 ounces to balance the wheel, attach an 1.5 ounce weight on the outer edge of the rim and an 1.5 ounce weight on the inner edge of the rim at the same location.

NOTE: It is possible that the weights may not balance the wheel when the heavy portion of both the wheel and the tire are located on the same side. If this condition exists, deflate the tire and rotate it approximately half way around the rim and then re-inflate the tire and repeat the process.

OPTIONAL "A-B-C" WEIGHT METHOD OF BALANCING

1. Lay four "A" weights in position on the Light side of the tire/ rim. The weights are used in pairs with one of the weights of each pair located on the rim flange and the other weight directly behind it. (See Fig. 2 & 3)

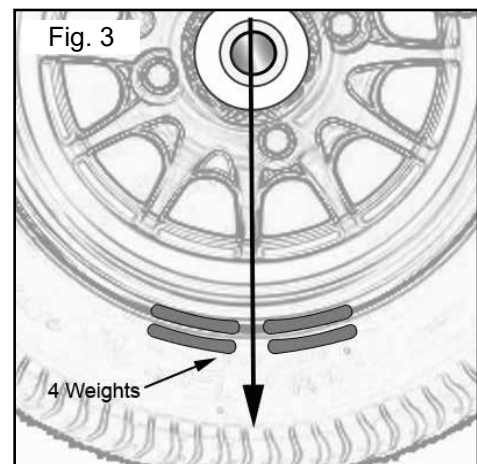
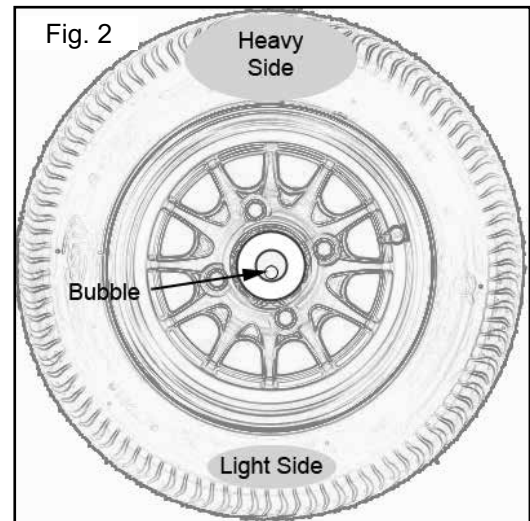

2. If the bubble does not float to the middle of or beyond the circle, replace the "A" weights with four "B" weights (heavier). Likewise if the bubble does not center or go beyond the circle replace the four "B" weights with four "C" weights (heavier).

NOTE: It is possible that the four "C" weights may not balance the wheel when the heavy portion of both the wheel and the tire are located on the same side. If this condition exists, deflate the tire and rotate it approximately half way around the rim and then re-inflate the tire and repeat the process.

3. After you have determined which four weights to use and have placed them in pairs as shown in Figure 1, move the pairs in opposite directions from each other around the rim equal distance from the starting point, until the bubble is centered in the black circle. (See Fig. 4)

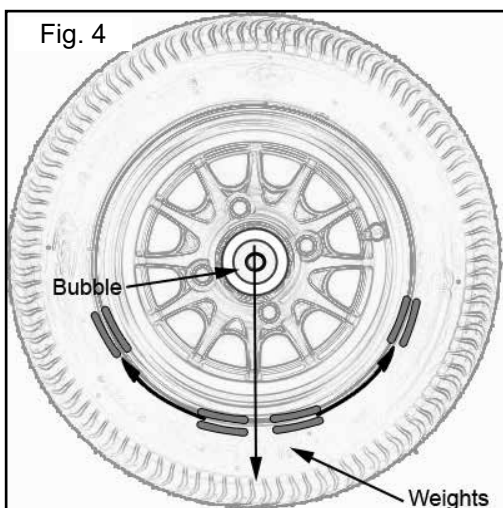

4. Draw a vertical chalk line on the tread of the tire directly in the middle of each pair of weights. To accurately draw lines, sight through the middle of the weights to the middle of the balancer. (See Fig. 5)

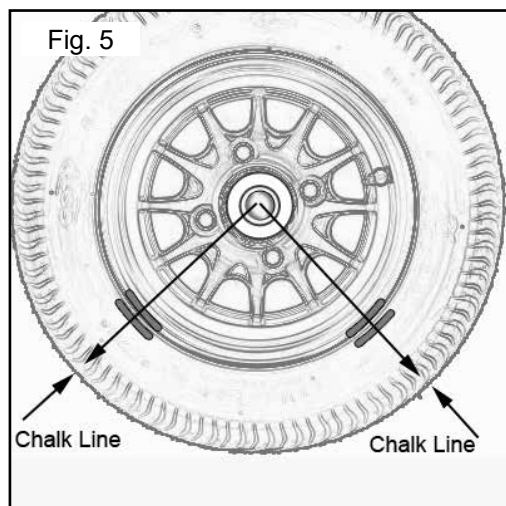

5. Remove the two pairs of weights and lift the tire from the balancer. Attach one weight on the inside (underside) of the tire directly in line with each of the chalk marked on the tire thread.

6. Return the wheel to the balancer "outside" face up and lay one each of the remaining weights on the rim of approximately in line with each chalk lines. To check for balance move weights slightly apart or together until the bubble is in the middle of the black circle. Attach the remaining weights to the outside of the rim flange.

CARE AND MAINTENANCE

1. Keep the pivot pin located in the upper end of the support shaft lubricated with 10 weight oil or equivalent. (See Fig. 6)

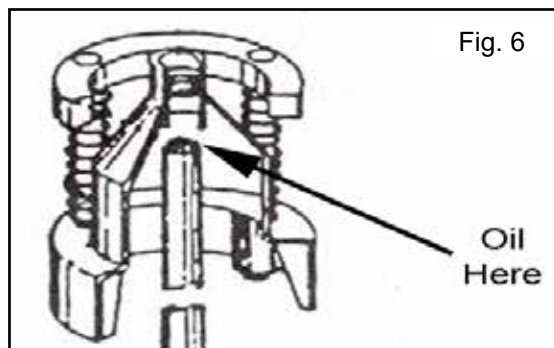

2. Keep the four Guide Post and spring assemblies are kept free of dirt and debris and lightly lubricated.

3. Keep the Flange/Head Assembly free of dirt and foreign materials.

TECHNICAL SPECIFICATIONS

| | |
|---------------------|---------------------------------|
| Hub Hole Diameter: | 1.5" - 4.5"; (39 mm - 114.3 mm) |
| Bubble Sensitivity: | .788 Sec. Per 2 mm |
| Overall Height: | 22"; (559 mm) |
| Overall Width: | 12"; (305 mm) |
| Overall Weight: | 14 lbs.; (6.35 kgs) |
| Base Diameter: | 12" ; (305 mm) |
| Shipping Weight: | 12.5 lbs; (5.6 kgs) |
| Calibrated | @ 90°, 180°, 270° & 360° |

For additional copies
or further information, contact:
BendPak Inc. / Ranger Products
1645 Lemonwood Dr.,
Santa Paula, CA. 93060
1-805-933-9970
www.bendpak.com
www.rangerproducts.com

Part Number Listing and Parts Diagram

| Part # | Description | Qty |
|--------|--------------------|-----|
| 1 | Flange Set | 1 |
| 2 | Spring | 4 |
| 3 | Screw ST2.2x10 | 3 |
| 4 | Level Bubble | 1 |
| 5 | Washer | 1 |
| 6 | Bubble Spring | 1 |
| 7 | Balancing Cone Set | 1 |
| 8 | Retaining Pin | 2 |
| 9 | Shaft | 1 |
| 10 | Nut M20x1.5A | 2 |
| 11 | Flat Washer | 1 |
| 12 | Base | 1 |
| 13 | Lock Washer | 1 |

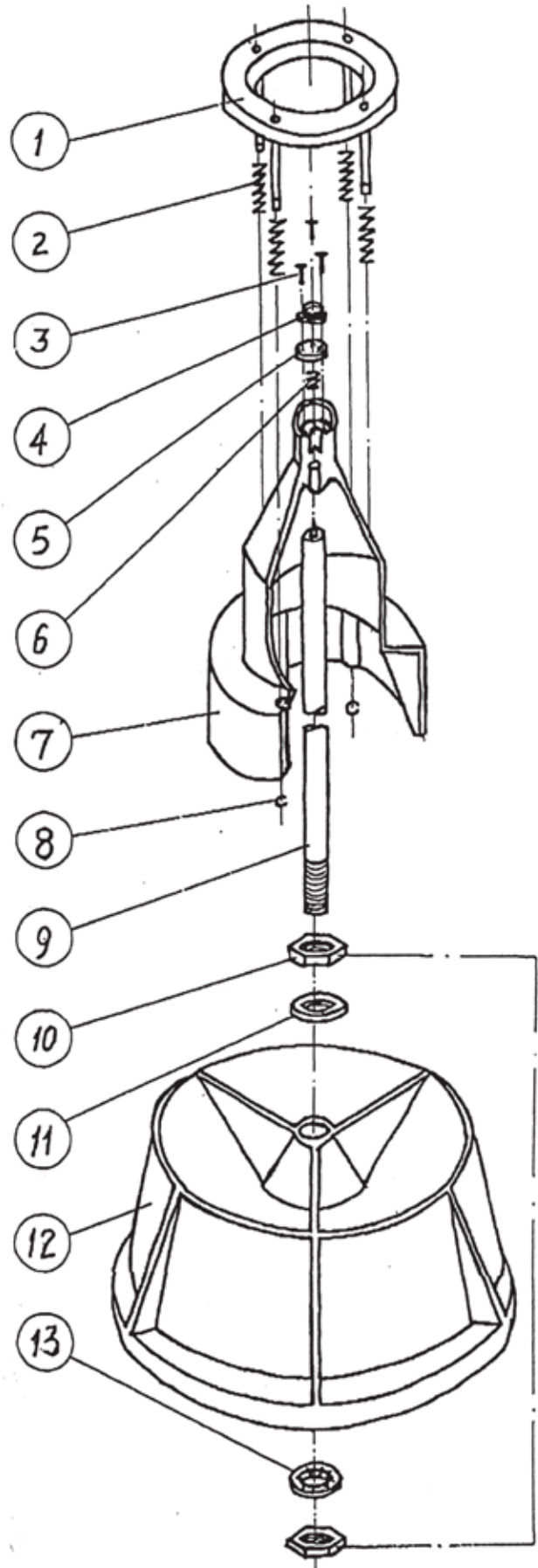



1645 Lemonwood Dr. ● Santa Paula, CA. 93060, USA
Toll Free: 1(800) 253-2363

FOR TECHNICAL SUPPORT
1-(800) 253-2363 Ext. 196
TO ORDER PARTS
1-(800) 253-2363 Ext. 191