



Brand: BendPak
Model: XPR-10A
Description: 10,000-Lb. Capacity Two-Post Lift / Asymmetric Clearfloor

The Perfect Car Lift Solution

Our XPR-10A asymmetric two-post lift offers the convenience of wide or narrow installation wrapped up into one configurable package. This durable, safe and reliable car lift features an expandable top beam and Tru-Metric arms to suit virtually every vehicle lifting requirement. The powerful and secure XPR-10A is an incredibly rapid lift with a robust menu of features to increase efficiency and productivity. A simple, yet highly sophisticated lift design keeps service and maintenance costs to a minimum, delivering lower operating expenses and higher productivity. If you're looking to make more money in less time than ever before, you'll find that the new XPR-10A two-post lift is the perfect addition to your shop.

This true asymmetric lift features 30° rotated columns for added door-opening clearance and interior car access. The exclusive Tru-Metric carriage and arm design combines to give users the ability to load vehicles either symmetrically (centerline of vehicle at column) or asymmetrically (centerline of vehicle behind column).

Features

- 10,000-lb lifting capacity
- Expandable top beam accommodates wide or narrow drive-thru configuration
- Padded overhead safety shutoff bar
- Exclusive Tru-Metric arm design for more versatile arm positioning
- 30° rotated single-piece columns
- Single-point safety release
- Drop-end arms provide a lower pad height
- Dual hydraulic direct-drive cylinders
- Oversized 53" tall carriage for superior strength and durability
- Electric / hydraulic power system
- Large, 17" x 19" A36 steel base plate
- Self-lubricating dura-glide UHMW polyethylene bearing system
- Safety locks in each column spaced every 3"
- Automatic arm restraints
- Heavy-duty 1/2" aircraft-quality equalizer cables
- Oversized cable sheave diameter reduces cable fatigue
- 8-piece truck and van adapter set standard
- Triple-telescoping arm design
- Versatile drop-in contact pads with stackable adapters
- ETL Approved.



FREE 8-Pc. Truck Adapter Set



Lift arms shown with optional foot guards

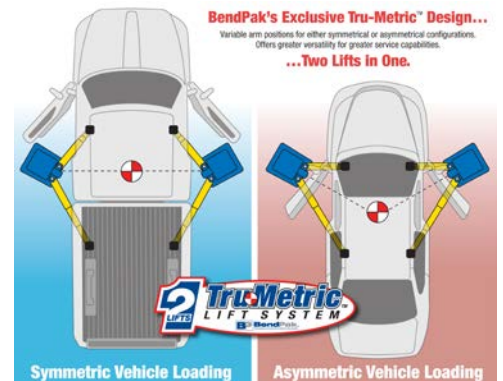

FLOORPLAN

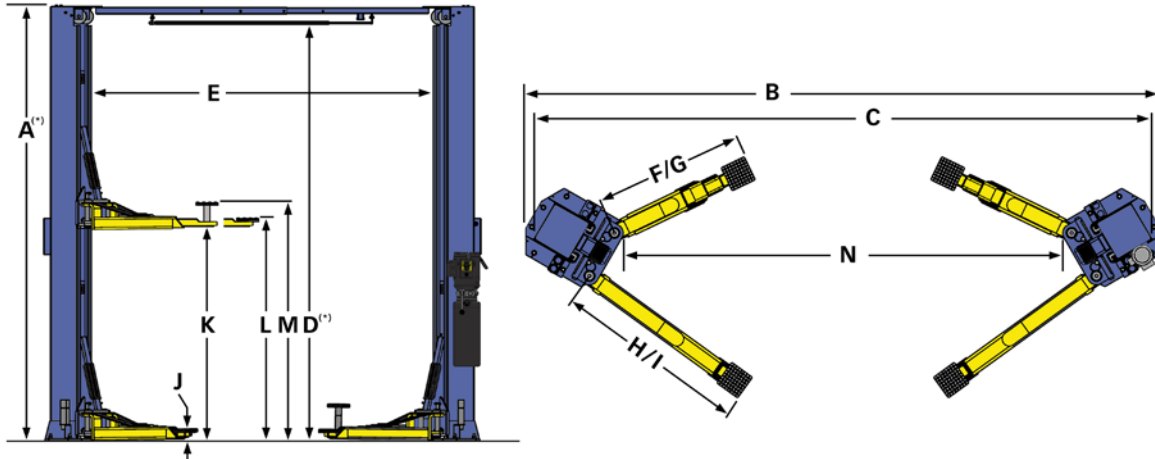

TWO-POST MODEL / HEAVY-DUTY / ASYMMETRIC

MODEL	XPR-10A
Lifting Capacity*	10,000 Lbs. / 4536 Kg.
*Max Capacity / Front Axle	5,000 Lbs. / 2268 Kg.
*Max Capacity / Rear Axle	5,000 Lbs. / 2268 Kg.
A - Height Overall: (*)	145" / 3683 mm.
B - Width Overall - NARROW CONFIGURATION	137" / 3480 mm.
B - Width Overall - WIDE CONFIGURATION	145" / 3683 mm.
C - Width Outside of Columns: (NARROW CONFIGURATION)	128" / 3251 mm.
C - Width Outside of Columns: (WIDE CONFIGURATION)	141" / 3581 mm.
D - Floor To Overhead Switch: (*)	141" / 3581 mm.
E - Inside Columns: (NARROW CONFIGURATION)	99" / 2515 mm.
E - Inside Columns: (WIDE CONFIGURATION)	112" / 2845 mm.
F - Reach (Front Arm Min.):	23-1/2" / 597 mm.
G - Reach (Front Arm Max.):	45-1/2" / 1156 mm.
H - Reach (Rear Arm Min.):	42-1/2" / 1079 mm.
I - Reach (Rear Arm Max.):	60" / 1524 mm.
J - Min. Pad Height:	4" / 102 mm.
K - Rise:	69" / 1753 mm.
L - Max Lift Height (Pad Only):	73" / 1854 mm.
M - Max Lift Height (6" Adapter):	79" / 2007 mm.
N - Drive-Thru Clearance: (NARROW CONFIGURATION)	89" / 22261 mm.
N - Drive-Thru Clearance: (WIDE CONFIGURATION)	102" / 2591 mm.
Motor (**)	220 VAC / 60 Hz. 1Ph.
Time of full Rise:	45 Seconds
Max Load Per Arm:	2,500 Lbs. / 1134 Kg.

* An optional bolt-on top extension for columns raises the overhead bar an additional 24". Must be ordered from factory at time of order.

** Special Voltages Available Upon Request.

The design, material and specifications are subject to change without notice.