

PLEASE READ THE ENTIRE CONTENTS OF THIS MANUAL PRIOR TO INSTALLATION AND OPERATION. BY PROCEEDING YOU AGREE THAT YOU FULLY UNDERSTAND AND COMPREHEND THE FULL CONTENTS OF THIS MANUAL. FORWARD THIS MANUAL TO ALL OPERATORS. FAILURE TO OPERATE THIS EQUIPMENT AS DIRECTED MAY CAUSE INJURY OR DEATH.

REV B 10-27-11



INSTALLATION AND OPERATION MANUAL

**ENGINE SUPPORT
MODEL:
RST-500ES**



Keep this operation manual near the machine at all times. Make sure that ALL USERS read this manual.

SHIPPING DAMAGE CLAIMS

When this equipment is shipped, title passes to the purchaser upon receipt from the carrier. Consequently, claims for the material damaged in shipment must be made by the purchaser against the transportation company at the time shipment is received.

BE SAFE

Your new Engine Support was designed and built with safety in mind. However, your overall safety can be increased by proper training and thoughtful operation on the part of the operator. DO NOT operate or repair this equipment without reading this manual and the important safety instructions shown inside.



1645 Lemonwood Dr.
Santa Paula, CA. 93060, USA
Toll Free 1-800-253-2363
Tel: 1-805-933-9970
Fax: 1-805-933-9160
www.bendpak.com

ENGINE SUPPORT

WARRANTY POLICY

Ranger Products™ are backed by over 35 years of manufacturing experience. Every Engine Support bearing the Ranger™ name is sold with the following warranty.

- Each Ranger Product™ is warranted to be free from defects in workmanship and material for a period of one year from the date of shipment provided that a written claim for such defect is made within that time.
- This warranty does not cover damage or defects caused by carelessness of the operator, misuse, abuse or abnormal use which in any way impairs the proper functioning of the equipment or by the use or addition of parts not manufactured by Ranger Products™ or its suppliers.

THIS WARRANTY IS EXPRESSLY MADE IN LIEU OF ANY AND ALL OTHER WARRANTIES EXPRESSED OR IMPLIED INCLUDING THE WARRANTIES OF MERCHANTABILITY AND FITNESS OR A PARTICULAR PURPOSE.

If your Ranger Products™ machine is not functioning properly, call your Ranger Products™ dealer immediately. On some occasions, an independent contractor may be hired to do the repairs. Within the warranty period, a customer should not hire his own contractor unless it is authorized in writing by Ranger Products™.

If it is necessary to return equipment for repairs, your dealer will so advise you. When returning equipment for repairs, empty, see that machines are properly crated and protected, and prepay transportation.

Defective parts replaced at no charge must be returned to your dealer or Ranger Products™ within 60 days of the date that the replacement parts are shipped; otherwise, you must pay for the replacement parts at the current selling price.

DEFINITIONS OF HAZARD LEVELS

Identify the hazard levels used in this manual with the following definitions and signal words:



DANGER!

Watch for this symbol: It Means: Immediate hazards which will result in severe personal injury or death.



WARNING!

Watch for this symbol: It Means: Hazards or unsafe practices which could result in severe personal injury or death.



CAUTION!

Watch for this symbol: It Means: Hazards or unsafe practices which may result in minor personal injury or product or property damage.



CAUTION!

Failure to follow danger, warning, and caution instructions may lead to serious personal injury or death to operator or bystander or damage to property.

Do not operate this machine until you read and understand all the dangers, warnings and cautions in this manual.



THIS SYMBOL POINTS OUT IMPORTANT SAFETY INSTRUCTIONS WHICH IF NOT FOLLOWED COULD ENDANGER THE PERSONAL SAFETY AND/OR PROPERTY OF YOURSELF AND OTHERS AND CAN CAUSE PERSONAL INJURY OR DEATH. READ AND FOLLOW ALL INSTRUCTIONS IN THIS MANUAL BEFORE ATTEMPTING TO OPERATE THIS MACHINE.

OPERATOR PROTECTIVE EQUIPMENT

Personal protective equipment helps keep equipment use safer. However, equipment does not take the place of safe operating practices. Always wear durable work clothing. Shop aprons or shop coats may also be worn, however loose fitting clothing should be avoided. Tight fitting leather gloves are recommended to protect operators. Sturdy leather work shoes with steel toes and oil resistant soles should be used by personnel to help prevent injury in typical shop activities.

Eye protection is essential during installation and operation. Safety glasses with side shields, goggles, or face shields are acceptable. Back belts provide support during lifting activities and are also helpful in providing operator protection. Consideration should also be given to the use of hearing protection if activity is performed in an enclosed area, or if noise levels are high.



OWNER'S RESPONSIBILITY

To maintain machine and user safety, the responsibility of the owner is to read and follow these instructions:

- ◆ Follow all installation instructions.
- ◆ Make sure installation conforms to all applicable Local, State, and Federal Codes, Rules, and Regulations; such as State and Federal OSHA Regulations and Electrical Codes.
- ◆ Carefully check the unit for correct initial function.
- ◆ Read and follow the safety instructions. Keep them readily available for machine operators.
- ◆ Make certain all operators are properly trained, know how to safely and correctly operate the unit, and are properly supervised.
- ◆ Allow unit operation only with all parts in place and operating safely.
- ◆ Carefully inspect the unit on a regular basis and perform all maintenance as required.
- ◆ Service and maintain the unit only with authorized or approved replacement parts.
- ◆ Keep all instructions permanently with the unit and all decal's on the unit clean and visible.

IMPORTANT SAFETY INSTRUCTIONS

Read these safety instructions entirely!



1. **READ AND UNDERSTAND** all safety warning procedures before operating equipment.
2. **KEEP HANDS AND FEET CLEAR.** Remove hands and feet from any moving parts.
3. **KEEP WORK AREA CLEAN.** Cluttered work areas invite injuries.
4. Consider work area environment. Do not expose equipment to rain. **DO NOT** use in damp or wet locations. Keep area well lit.
5. **ONLY TRAINED OPERATORS** should operate this equipment. All non-trained personnel should be kept away from work area. Never let non-trained personnel come in contact with, or operate machine.
6. **USE MACHINE CORRECTLY.** Improper use can lead to injury.
7. **DRESS PROPERLY.** Non-skid steel-toe footwear is recommended when operating machine.
8. **MAINTAIN WITH CARE.** Keep unit clean for better and safe performance. Follow manual for proper lubrication and maintenance instructions.
9. **DO NOT LOAD** this Engine Support beyond it's rated capacity.
10. **Before moving** the Engine Support, ensure the load is stable.
11. This Engine Support is designed for use on a vehicle only on hard level surfaces capable of sustaining the load.
12. **STAY ALERT.** Watch what you are doing. Use common sense. Be aware.
13. **CHECK FOR DAMAGED PARTS.** Check for condition of all moving parts, breakage of parts or any condition that may affect the machines operation. Do not use if any component is broken or damaged.
16. **NEVER** remove safety related components or device from the machine. Do not use if safety related components are damaged or missing.
17. **Immediately Replace** unreadable and missing warning labels.
18. **NO MODIFICATIONS** should be made to this Engine Support. Repairs to this equipment should be performed by a qualified technician.



UN-CRATING / PACKING INSTRUCTIONS

Carefully remove the crating and packing materials including all skid and pallet fasteners. Be careful when cutting steel banding material as items may become loose and fall causing personal harm or injury. Always wear gloves when un-crating the machine to prevent scratches, abrasions, or cuts due to the contact with packing materials. Remember to report any shipping damage to the carrier and make a notation on the delivery receipt.

TOOLS REQUIRED

Adjustable Wrench or Metric open end /combination wrenches.

INSTALLATION INSTRUCTIONS

1. Connect both Standing Brackets (9) to the Connector (8).
2. Insert the Connectors (8) through the Beam (1). Use the Washers (3) and the Lock Nuts (2) to attach the Connectors (8) to the Beam (1). Tighten the Lock Nuts (2).
3. Insert the Adjustable Screw (11) through the Beam (1). Use the Washers (6) and the Grip Handles (5) to attach the Adjustable Screw (11) to the Beam (1). Tighten the Grip Handles (5).
4. Attach the Chains (12) to the Adjustable Screw (11).
5. The Engine Support is now ready for use.



OPERATION INSTRUCTIONS

WARNING!
NEVER STAND, WORK, OR PLACE YOUR HAND(S) UNDER A OBJECT THAT IS BEING LIFTED BY THE ENGINE SUPPORT.
AN OBJECT FALLING FROM THE ENGINE SUPPORT CAN CAUSE SERIOUS INJURY.

1. Ensure the Rubber Supports are located securely in the Gutter of the vehicles Front Wing Panel. Check with the Vehicle manufacturer to ensure the selected support points are capable of handling the rated load of the engine or component being supported by the Engine Support.
2. Once positioned correctly, tighten both Lock Nuts (2) and all nuts and bolts etc., before applying the load.



Always check that the engine or component is properly secured to the support via a suitable chain or properly rated sling.



3. This equipment to be operated by professional personnel ONLY. Keep all visitors and children away from work area.

For additional copies
 or further information, contact:
 BendPak Inc. / Ranger Products
 1645 Lemonwood Dr.,
 Santa Paula, CA. 93060
 1-805-933-9970
 www.bendpak.com

SPECIFICATIONS	
Model No.	Capacity
RST-500ES	1,100 lbs 500 Kg

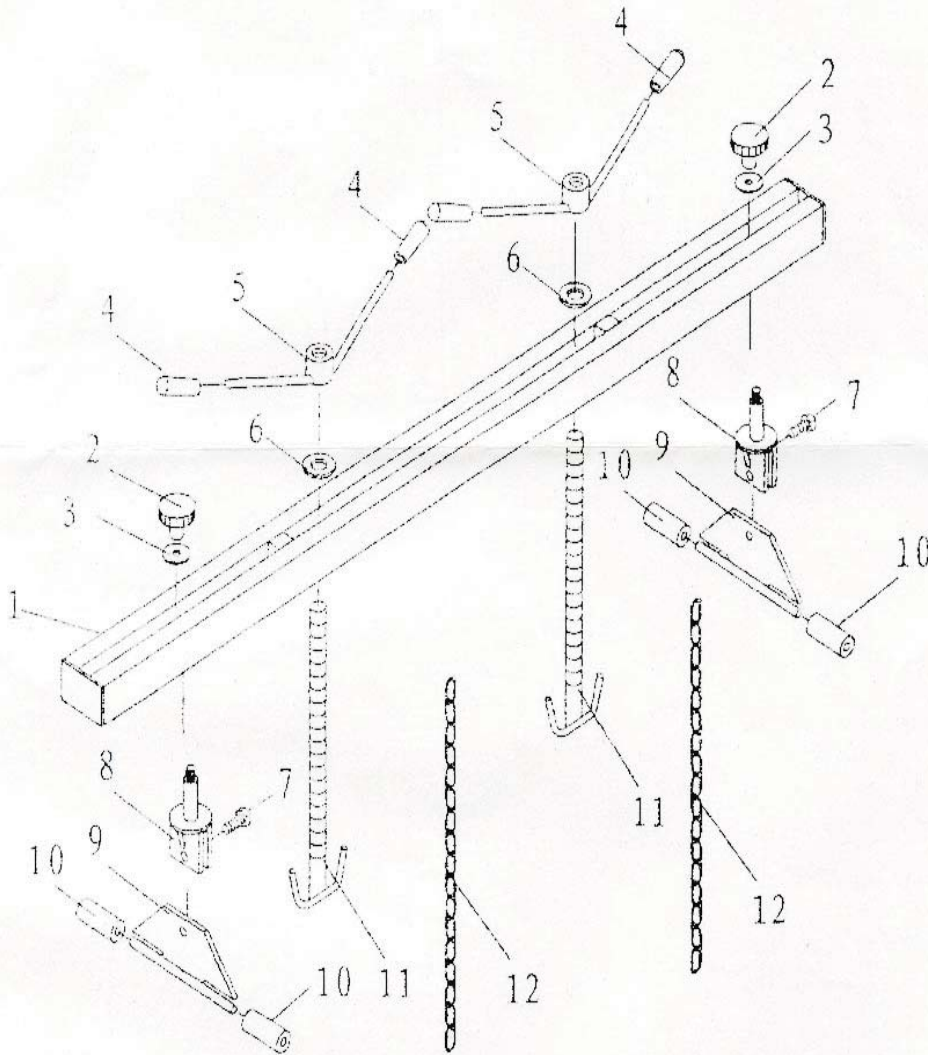

PART NO	DESCRIPTION	QTY	PART NO	DESCRIPTION	QTY
1	Beam	1	7	Bolt M12x25	2
2	Lock Nut	2	8	Connector	2
3	Washer	2	9	Standing Bracket	2
4	Handle Sleeve	4	10	Rubber Block	4
5	Grip Handle	2	11	Adjustable Screw	2
6	Washer	2	12	Chain	2

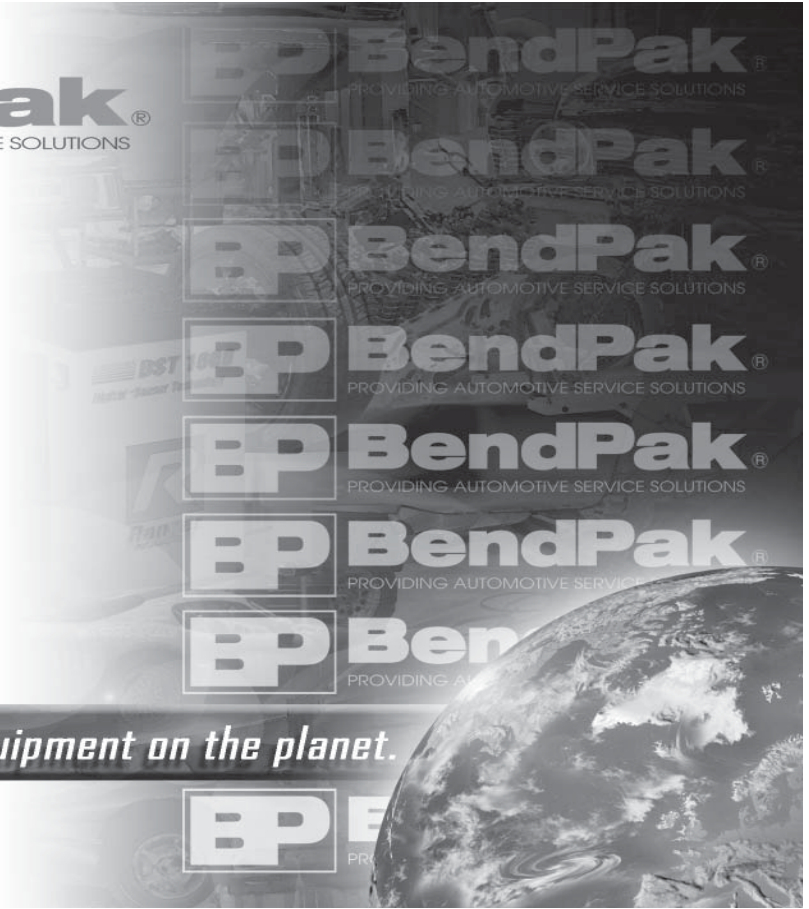

The best automotive service equipment on the planet.

**For Parts Or Service
Contact:**

**BendPak Inc. / Ranger Products
1645 Lemonwood Dr.
Santa Paula, CA. 93060**

**Tel: 1-805-933-9970
Toll Free: 1-800-253-2363
Fax: 1-805-933-9160**

www.bendpak.com

